



Chipsmall Limited consists of a professional team with an average of over 10 year of expertise in the distribution of electronic components. Based in Hongkong, we have already established firm and mutual-benefit business relationships with customers from,Europe,America and south Asia,supplying obsolete and hard-to-find components to meet their specific needs.

With the principle of “Quality Parts,Customers Priority,Honest Operation,and Considerate Service”,our business mainly focus on the distribution of electronic components. Line cards we deal with include Microchip,ALPS,ROHM,Xilinx,Pulse,ON,Everlight and Freescale. Main products comprise IC,Modules,Potentiometer,IC Socket,Relay,Connector.Our parts cover such applications as commercial,industrial, and automotives areas.

We are looking forward to setting up business relationship with you and hope to provide you with the best service and solution. Let us make a better world for our industry!



## Contact us

Tel: +86-755-8981 8866 Fax: +86-755-8427 6832

Email & Skype: info@chipsmall.com Web: www.chipsmall.com

Address: A1208, Overseas Decoration Building, #122 Zhenhua RD., Futian, Shenzhen, China



# STK5F1U3E2D-E

## Advance Information Intelligent Power Module (IPM) 600 V, 50 A



ON Semiconductor®

www.onsemi.com

### Overview

This “Inverter Power IPM” is highly integrated device containing all High Voltage (HV) control from HV-DC to 3-phase outputs in a single DIP module (Dual-In line Package). Output stage uses IGBT / FRD technology and implements Under Voltage Protection (UVP) and Over Current Protection (OCP) with a Fault Detection output flag. Internal Boost diodes are provided for high side gate boost drive.

### Function

- Single control power supply due to Internal bootstrap circuit for high side pre-driver circuit
- All control input and status output are at low voltage levels directly compatible with microcontrollers
- Cross conduction prevention
- Externally accessible embedded thermistor for substrate temperature measurement
- The level of the over-current protection current is adjustable with the external resistor, “RSD”

### Certification

- UL1557 (File Number : E339285)

### Specifications

#### Absolute Maximum Ratings at T<sub>c</sub> = 25°C

Parameter	Symbol	Remarks	Ratings	Unit
Supply voltage	V <sub>CC</sub>	P to N, surge < 500 V *1	450	V
Collector-emitter voltage	V <sub>CE</sub>	P to U, V, W or U, V, W to N	600	V
Output current	I <sub>o</sub>	P, N, U, V, W terminal current	±50	A
		P, N, U, V, W terminal current, T <sub>c</sub> = 100°C	±25	
Output peak current	I <sub>op</sub>	P, N, U, V, W terminal current, PW = 1 ms	±76	A
Pre-driver supply voltage	VD1, 2, 3, 4	VB1 to VS1, VB2 to VS2, VB3 to VS3, V <sub>DD</sub> to V <sub>SS</sub> *2	20	V
Input signal voltage	V <sub>IN</sub>	HIN1, 2, 3, LIN1, 2, 3	-0.3 to V <sub>DD</sub>	V
FAULT terminal voltage	V <sub>FAULT</sub>	FAULT terminal	-0.3 to V <sub>DD</sub>	V
Maximum loss	P <sub>d</sub>	IGBT per channel	67.5	W
Junction temperature	T <sub>j</sub>	IGBT,FRD	150	°C
Storage temperature	T <sub>stg</sub>		-40 to +125	°C
Operating temperature	T <sub>c</sub>	IPM case	-20 to +100	°C
Tightening torque	MT	A screw part at use M4 type screw *3	1.17	Nm
Withstand voltage	Vis	50 Hz sine wave AC 1 minute *4	2000	VRMS

Reference voltage is N terminal = V<sub>SS</sub> terminal voltage unless otherwise specified.

\*1 : Surge voltage developed by the switching operation due to the wiring inductance between the P and N terminals.

\*2 : Terminal voltage : VD1 = VB1 to VS1, VD2 = VB2 to VS2, VD3 = VB3 to VS3, VD4 = V<sub>DD</sub> to V<sub>SS</sub>.

\*3 : Flatness of the heat-sink should be 0.25 mm and below.

\*4 : Test conditions : AC 2500 V, 1 s.

Stresses exceeding those listed in the Maximum Ratings table may damage the device. If any of these limits are exceeded, device functionality should not be assumed, damage may occur and reliability may be affected.

This document contains information on a new product. Specifications and information herein are subject to change without notice.

### ORDERING INFORMATION

See detailed ordering and shipping information on page 14 of this data sheet.

# STK5F1U3E2D-E

**Electrical Characteristics** at Tc = 25°C, VD1, VD2, VD3, VD4 = 15 V

Parameter	Symbol	Conditions	Test circuit	Ratings			Unit	
				Min.	Typ.	Max.		
<b>Power output section</b>								
Collector to emitter cut-off current	ICE	VCE = 600 V	Fig.1	-	-	100	μA	
Bootstrap diode reverse current	IR(BD)	VR(BD) = 600 V		-	-	100	μA	
Collector to emitter saturation voltage	VCE(sat)	Ic = 50 A	Upper side	Fig.2	-	1.7	2.6	V
			Lower side		-	2.3	3.2	
		Ic = 25 A, Tj = 100°C	Upper side		-	1.35	-	
			Lower side		-	1.75	-	
Diode forward voltage	VF	IF = 50 A	Upper side	Fig.3	-	1.8	2.7	V
			Lower side		-	2.4	3.3	
		IF = 25 A, Tj = 100°C	Upper side		-	1.45	-	
			Lower side		-	1.85	-	
Junction to case thermal resistance	θj-c(T)	IGBT	-	-	1.5	-	°C/W	
	θj-c(D)	FWD	-	-	1.8	-	°C/W	
<b>Control (Pre-driver) section</b>								
Pre-drive power supply consumption current	ID	VD1, 2, 3 = 15 V	Fig.4	-	0.05	0.4	mA	
		VD4 = 15 V		-	1.0	4.0		
High level input voltage	Vin H	HIN1, HIN2, HIN3,	-	2.5	-	-	V	
Low level input voltage	Vin L	LIN1, LIN2, LIN3 to VSS	-	-	-	0.8	V	
Logic 1 input leakage current	IIN+	VIN = +3.3 V			100	195	μA	
Logic 0 input leakage current	IIN-	VIN = 0 V				1	μA	
<b>Protection section</b>								
Over-current protection electric current	ISD	PW = 100 μs, RSD = 0 Ω	Fig.5	57	-	76	A	
VDD and VBx supply undervoltage positive going input threshold	VddUV+ VBxUV+			10.6	11.1	11.6	V	
VDD and VBx supply undervoltage negative going input threshold	VddUV- VBxUV-			10.4	10.9	11.4	V	
VDD and VBx supply undervoltage Ilockout hysteresis	VddUVH VBxUVH				0.2		V	
FAULT terminal input electric current	IOSD	VFAULT = 0.1 V	-	1	1.5	-	mA	
FAULT clearance delay time	FLTCLR	From time fault condition clear	-	18	-	80	ms	
Thermistor for substrate temperature monitor	Rt	Resistance between the TH(18) and VSS(20) terminals	-	90	-	110	kΩ	
<b>Switching character</b>								
Switching time	tON	Io = 50 A, Inductive load	Fig.6	-	0.7	1.5	μs	
	tOFF			-	1.1	2.1	μs	
Turn-on switching loss	Eon	Io = 50 A, VCC = 300 V, VD = 15 V, L = 280 μH	Fig.6	-	1100	-	μJ	
Turn-off switching loss	Eoff			-	1220	-	μJ	
Total switching loss	Etot			-	2320	-	μJ	
Turn-on switching loss	Eon	Io = 25 A, VCC = 300 V, VD = 15 V, L = 280 μH, Tc = 100°C	Fig.6	-	620	-	μJ	
Turn-off switching loss	Eoff			-	790	-	μJ	
Total switching loss	Etot			-	1410	-	μJ	
Diode reverse recovery energy	Erec	Io = 25 A, VCC = 300 V, VD = 15 V, L = 280 μH, Tc = 100°C	Fig.6	-	27	-	μJ	
Diode reverse recovery time	Trr			-	80	-	ns	
Reverse bias safe operating area	RBSOA	Io = 76 A, VCE = 450 V		Full square				
Short circuit safe operating area	SCSOA	VCE = 400 V, Tc = 100°C		4			μs	
Electric current output signal level	ISO	Io = 50 A	-	0.427	0.45	0.474	V	

Reference voltage is N terminal = VSS terminal voltage unless otherwise specified.

Product parametric performance is indicated in the Electrical Characteristics for the listed test conditions, unless otherwise noted. Product performance may not be indicated by the Electrical Characteristics if operated under different conditions.

# STK5F1U3E2D-E

## Notes

1. When the internal protection circuit operates, a Fault signal is turned ON (When the Fault terminal is low level, Fault signal is ON state : output form is open DRAIN) but the Fault signal does not latch. After protection operation ends, it returns automatically within about 18 ms to 80 ms and resumes operation beginning condition. So, after Fault signal detection, set all input signals to OFF (Low) at once. However, the operation of pre-drive power supply low voltage protection (UVLO : with hysteresis about 0.2 V) is as follows.

### Upper side :

The gate is turned off and will return to regular operation when recovering to the normal voltage, but the latch will continue till the input signal will turn 'low'.

### Lower side :

The gate is turned off and will automatically reset when recovering to normal voltage. It does not depend on input signal voltage.

2. When assembling the IPM on the heat sink with M4 type screw, tightening torque range is 0.79 Nm to 1.17 Nm.

3. The pre-drive low voltage protection is the feature to protect devices when the pre-driver supply voltage falls due to an operating malfunction.

## Pin Assignment

Pin No.	Name	Description	Pin No.	Name	Description
1	VB1	High side floating supply voltage 1	44	P	Positive bus input voltage
2	VS1	High side floating supply offset voltage	43	P	Positive bus input voltage
3	-	Without pin	42	P	Positive bus input voltage
4	VB2	High side floating supply voltage 2	41	-	Without pin
5	VS2	High side floating supply offset voltage	40	N	Negative bus input voltage
6	-	Without pin	39	N	Negative bus input voltage
7	VB3	High side floating supply voltage 3	38	N	Negative bus input voltage
8	VS3	High side floating supply offset voltage	37	-	Without pin
9	-	Without pin	36	U	U-phase output
10	HIN1	Logic input high side driver-Phase1	35	U	U-phase output
11	HIN2	Logic input high side driver-Phase2	34	U	U-phase output
12	HIN3	Logic input high side driver-Phase3	33	-	Without pin
13	LIN1	Logic input low side driver-Phase1	32	V	V-phase output
14	LIN2	Logic input low side driver-Phase2	31	V	V-phase output
15	LIN3	Logic input low side driver-Phase3	30	V	V-phase output
16	FAULT	Fault out (open drain)	29	-	Without pin
17	ISO	Current monitor pin	28	W	W-phase output
18	TH	Thermistor out	27	W	W-phase output
19	VDD	+15 V main supply	26	W	W-phase output
20	VSS	Negative main supply	25	-	Without pin
21	ISD	Over-current protection level setting pin	24	NC	-
22	NC	-	23	NC	-

# STK5F1U3E2D-E

## Block Diagram

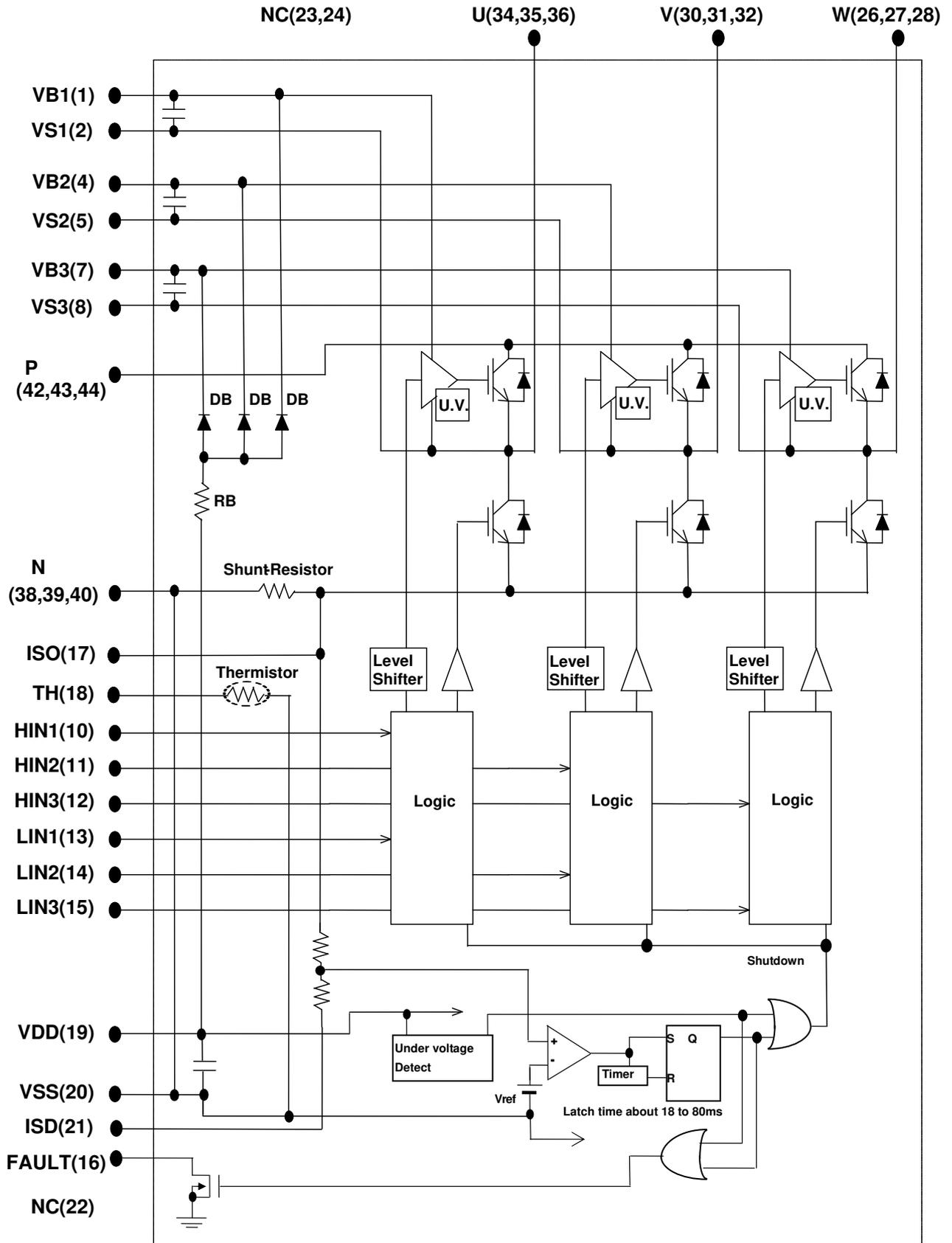

# STK5F1U3E2D-E

## Test Circuit

(The tested phase : U+ shows the upper side of the U phase and U- shows the lower side of the U phase)

### ■ ICE / IR(BD)

	U+	V+	W+	U-	V-	W-
M	42	42	42	34	30	26
N	34	30	26	38	38	38

	U(BD)	V(BD)	W(BD)
M	1	4	7
N	20	20	20

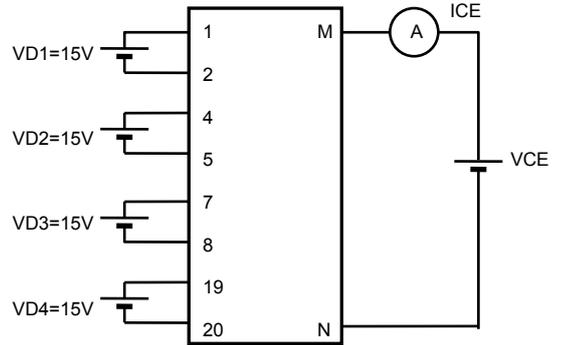

Fig.1

### ■ VCE(sat) (Test by pulse)

	U+	V+	W+	U-	V-	W-
M	42	42	42	34	30	26
N	34	30	26	17	19	21
m	10	11	12	13	14	15

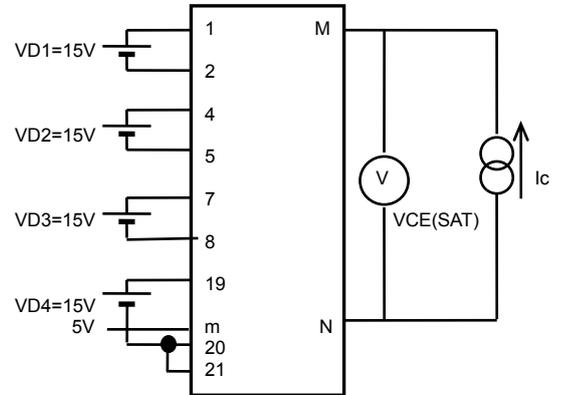

Fig.2

### ■ VF (Test by pulse)

	U+	V+	W+	U-	V-	W-
M	42	42	42	34	30	26
N	34	30	26	38	38	38

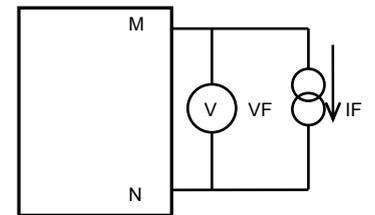

Fig.3

### ■ ID

	VD1	VD2	VD3	VD4
M	1	4	7	19
N	2	5	8	20

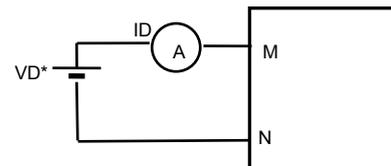

Fig.4

# STK5F1U3E2D-E

## ■ ISD

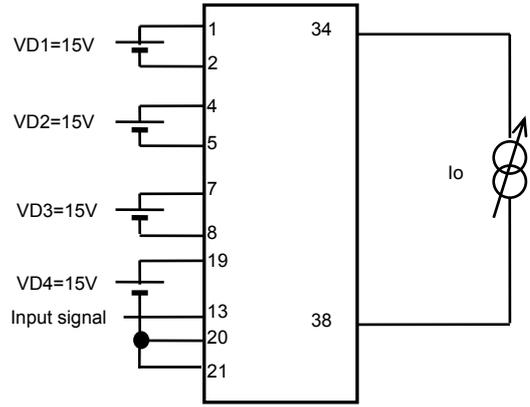
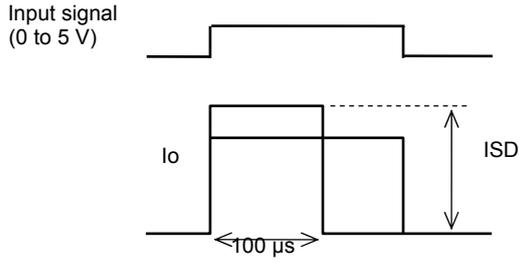

Fig.5

## ■ Switching time (The circuit is a representative example of the lower side U phase)

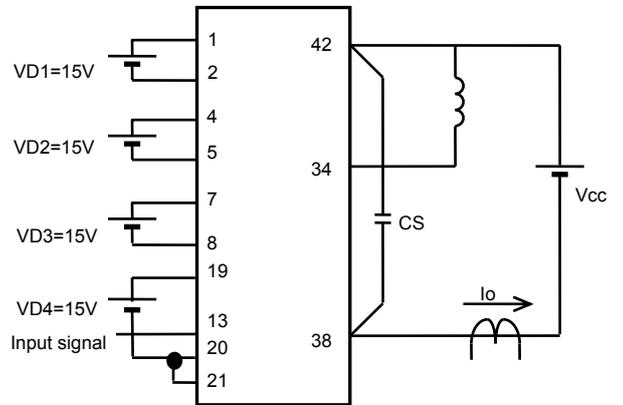
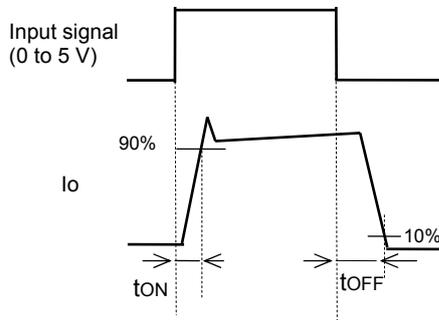

Fig.6

## ■ RB-SOA (The circuit is a representative example of the lower side U phase)

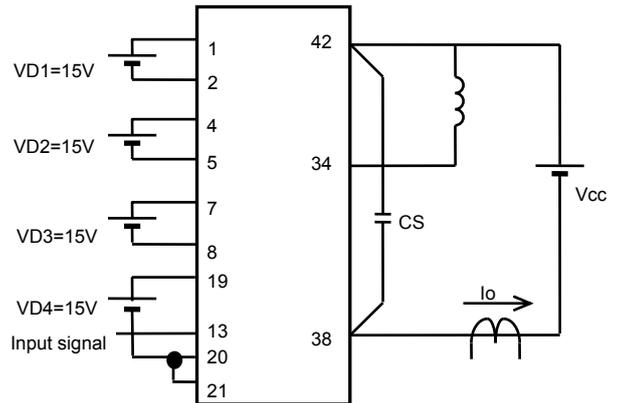
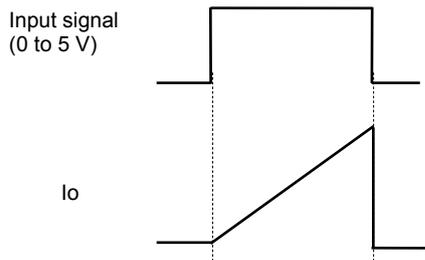

Fig.7

Logic Timing Chart

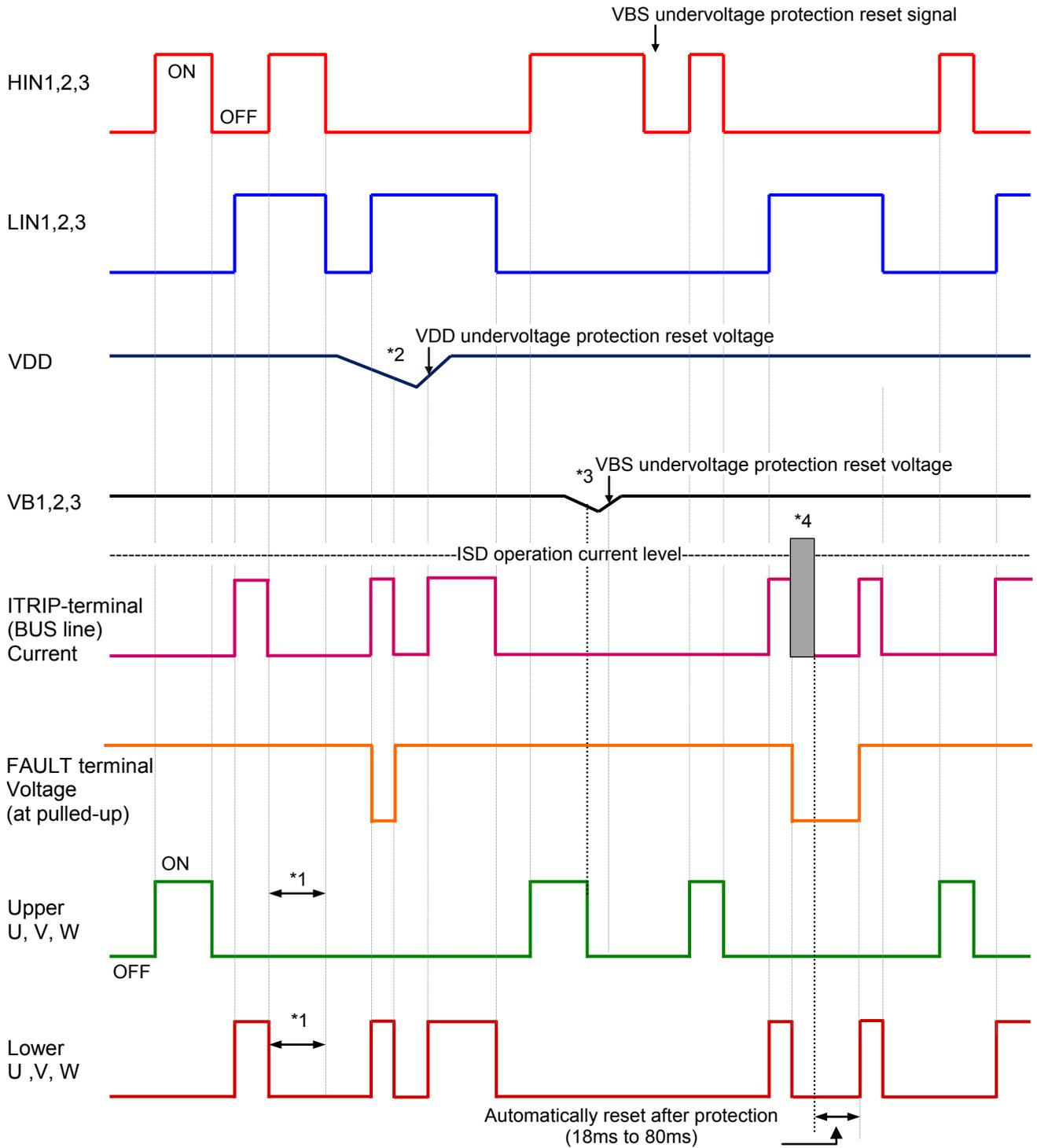

Fig. 8

Notes

- \*1 : Diagram shows the prevention of shoot-through via control logic. More dead time to account for switching delay needs to be added externally.
- \*2 : When V<sub>DD</sub> decreases all gate output signals will go low and cut off all of 6 IGBT outputs. part. When V<sub>DD</sub> rises the operation will resume immediately.
- \*3 : When the upper side gate voltage at VB1, VB2 and VB3 drops only, the corresponding upper side output is turned off. The outputs return to normal operation immediately after the upper side gat voltage rises.
- \*4 : In case of over current detection, all IGBT's are turned off and the FAULT output is asserted. Normal operation resumes in 18 to 80 ms after the over current condition is removed.

# STK5F1U3E2D-E

## Logic level table

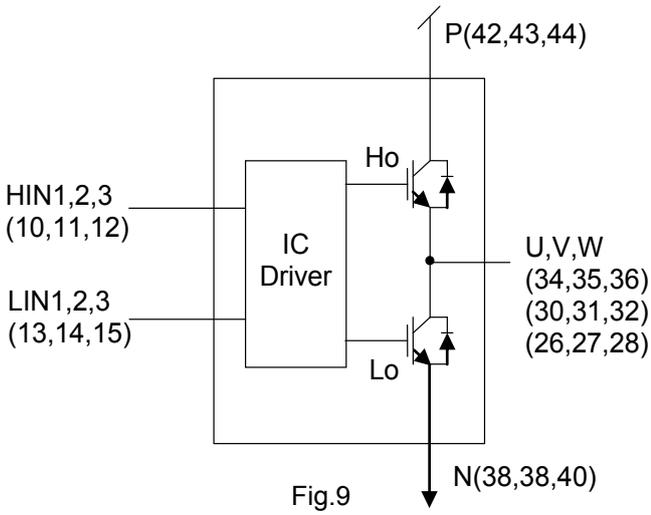

FAULT*	HIN1,2,3	LIN1,2,3	U,V,W
1	1	0	Vbus
1	0	1	0
1	0	0	Off
1	1	1	Off
0	X	X	Off

\* With pulled-up resistor

## Application Circuit Example

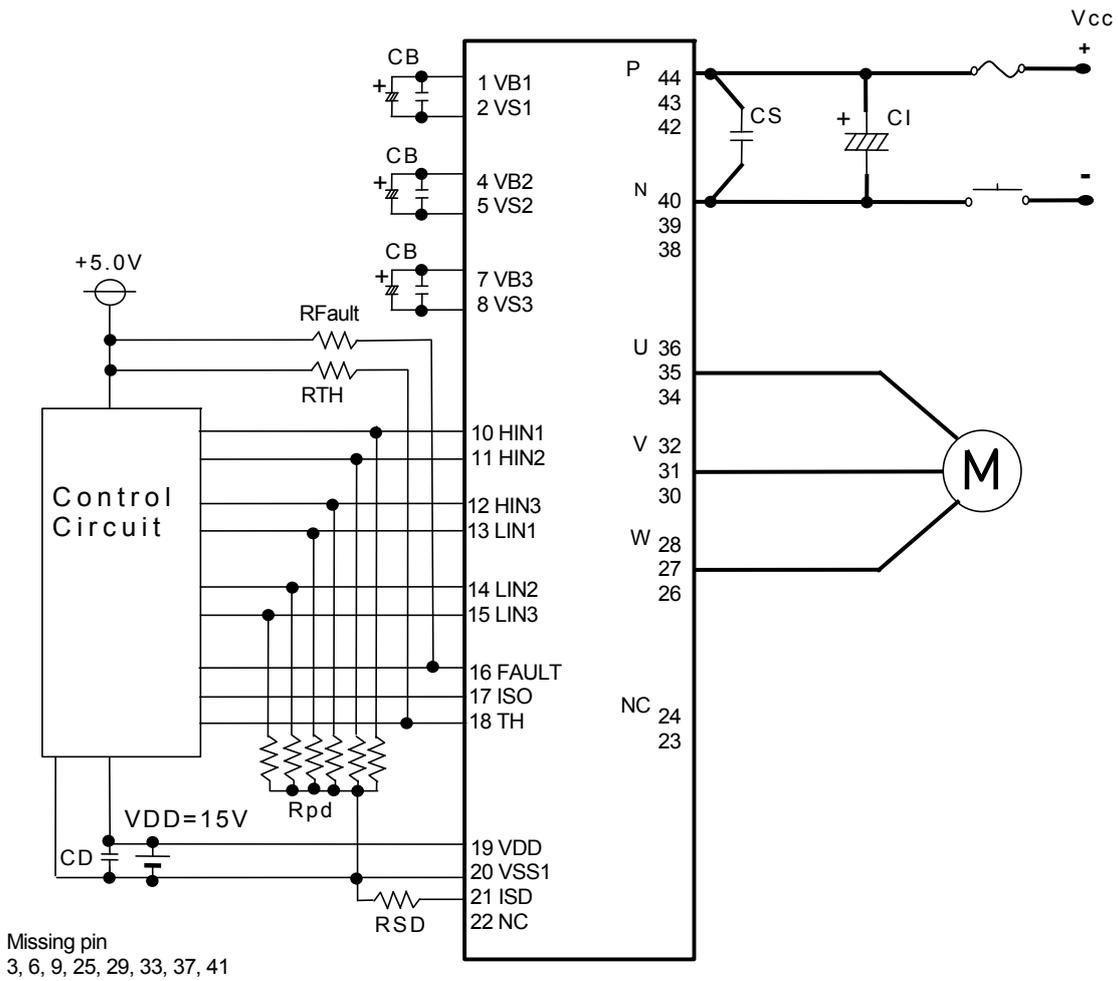

# STK5F1U3E2D-E

## Recommended Operating Conditions at Tc = 25°C

Parameter	Symbol	Conditions	Ratings			Unit
			Min	Typ	Max	
Supply voltage	VCC	P to N	0	280	450	V
Pre-driver supply voltage	VD1, 2, 3	VB1 to VS1, VB2 to VS2, VB3 to VS3	12.5	15	17.5	V
	VD4	VDD to VSS *1	13.5	15	16.5	
Input ON voltage	VIN(ON)	HIN1, HIN2, HIN3, LIN1, LIN2, LIN3	3.0	–	VDD	V
Input OFF voltage	VIN(OFF)		0	–	0.8	
PWM frequency	fPWM		1	–	20	kHz
Dead time	DT	Turn-off to turn-on (external)	2	–	–	μs
Allowable input pulse width	PWIN	ON pulse width/OFF pulse width	1	–	–	μs
Tightening torque	MT	'M4' type screw	0.79	–	1.17	Nm

\*1 Pre-driver power supply (VD4 = 15 ±1.5 V) must have the capacity of I<sub>o</sub> = 20 mA (DC), 0.5 A (Peak).

Functional operation above the stresses listed in the Recommended Operating Ranges is not implied. Extended exposure to stresses beyond the Recommended Operating Ranges limits may affect device reliability.

## Usage Precautions

1. This IPM includes bootstrap diode and resistors. Therefore, by adding a capacitor “CB”, a high side drive voltage is generated ; each phase requires an individual bootstrap capacitor. The recommended value of CB is in the range of 1 to 47 μF, however this value needs to be verified prior to production. If selecting the capacitance more than 47 μF (±20%), connect a resistor (about 20 Ω) in series between each 3-phase upper side power supply terminals (VB1, 2, 3) and each bootstrap capacitor.  
When not using the bootstrap circuit, each upper side pre-drive power supply requires an external independent power supply.
2. It is essential that wiring length between terminals in the snubber circuit be kept as short as possible to reduce the effect of surge voltages. Recommended value of “CS” is in the range of 0.1 to 10 μF.
3. “ISO” (pin 17) is terminal for current monitor. When the pull-down resistor is used, please select it more than 5.6 kΩ.
4. “FAULT” (pin 16) is open DRAIN output terminal. (Active Low). Pull up resistor is recommended more than 5.6 kΩ.
5. Inside the IPM, a thermistor used as the temperature monitor for internal substrate is connected between VSS terminal and TH terminal, therefore, an external pull up resistor connected between the TH terminal and an external power supply should be used. The temperature monitor example application is as follows, please refer the Fig.11, and Fig.12 below.
6. The pull down resistor of 33 kΩ is provided internally at the signal input terminals. An external resistor of 2.2 kΩ to 3.3 kΩ should be added to reduce the influence of external wiring noise.
7. The over-current protection feature is not intended to protect in exceptional fault condition. An external fuse is recommended for safety.
8. When “N” and “VSS” terminal are short-circuited on the outside, level that over-current protection (ISD) might be changed from designed value as IPM. Please check it in your set (“N” terminal and “VSS” terminal are connected in IPM).
9. The over-current protection function operates normally when an external resistor RSD is connected between ISD and VSS terminals. Be sure to connect this resistor. The level of the overcurrent protection can be changed according to the RSD value.
10. When input pulse width is less than 1.0 μs, an output may not react to the pulse. (Both ON signal and OFF signal)

This data shows the example of the application circuit, does not guarantee a design as the mass production set.

# STK5F1U3E2D-E

## The characteristic of thermistor

Parameter	Symbol	Condition	Min	Typ.	Max	Unit
Resistance	$R_{25}$	$T_c = 25^\circ\text{C}$	97	100	103	$\text{k}\Omega$
Resistance	$R_{100}$	$T_c = 100^\circ\text{C}$	4.93	5.38	5.88	$\text{k}\Omega$
B-Constant (25 to $50^\circ\text{C}$ )	B		4165	4250	4335	K
Temperature Range			-40		+125	$^\circ\text{C}$

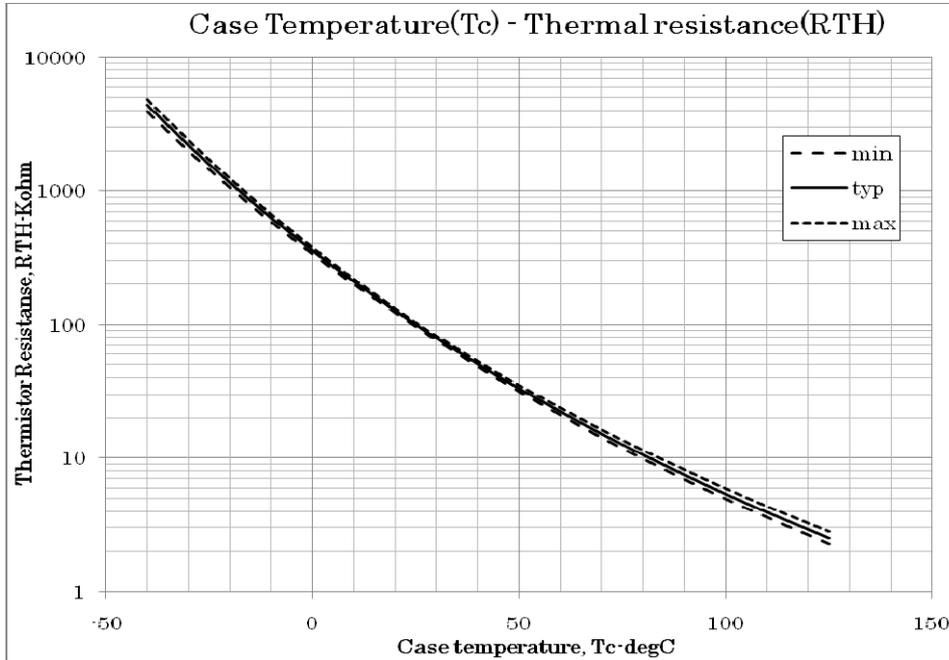

Fig.11 Variation of thermistor resistance with temperature

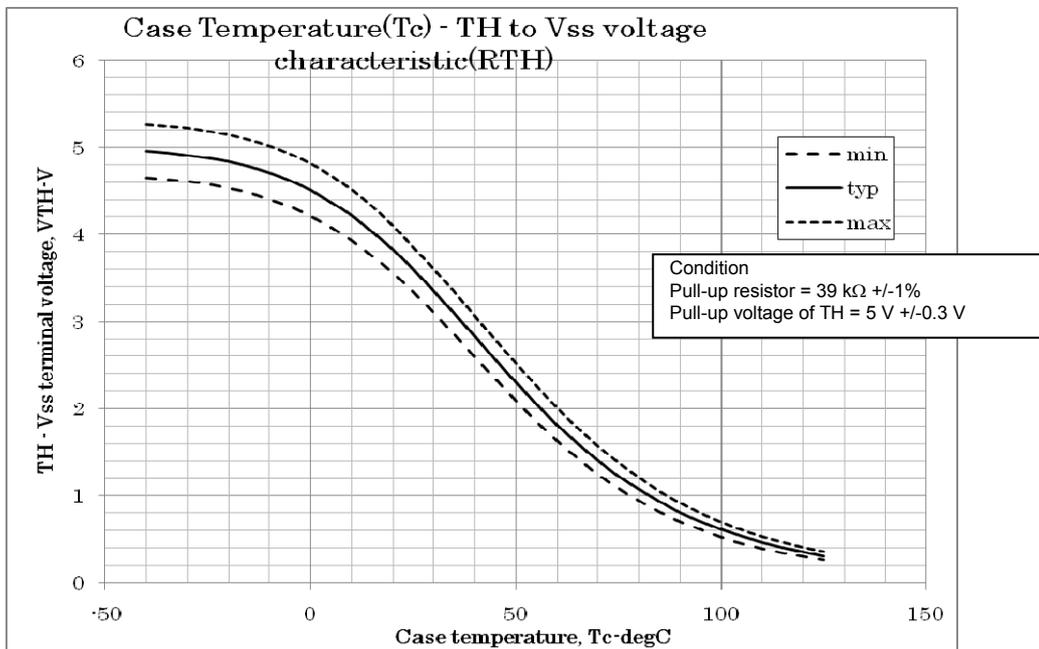

Fig.12 Variation of temperature sense voltage with thermistor temperature

Maximum Phase current

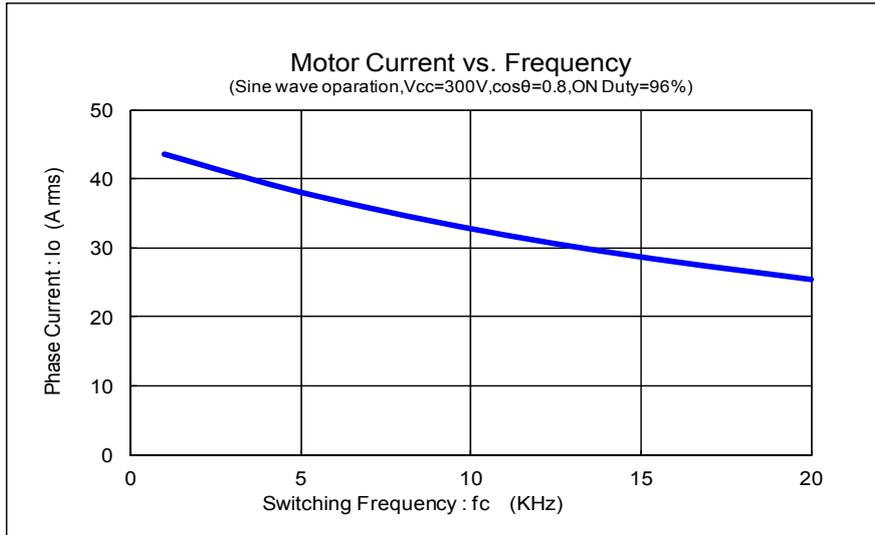

Fig.13 Maximum sinusoidal phase current as function of switching frequency at  $T_c = 100^\circ C$ ,  $V_{CC} = 300 V$

Switching waveform

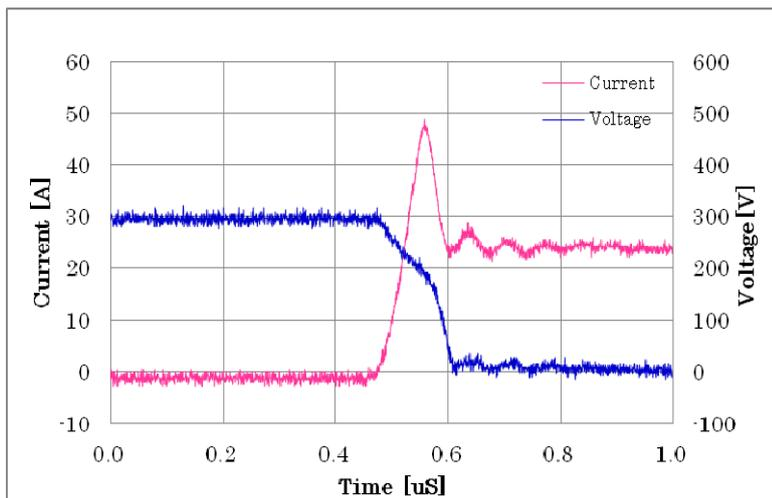

Fig. 14 IGBT Turn-on. Typical turn-on waveform at  $T_c = 100^\circ C$ ,  $V_{CC} = 300 V$ ,  $I_c = 25 A$

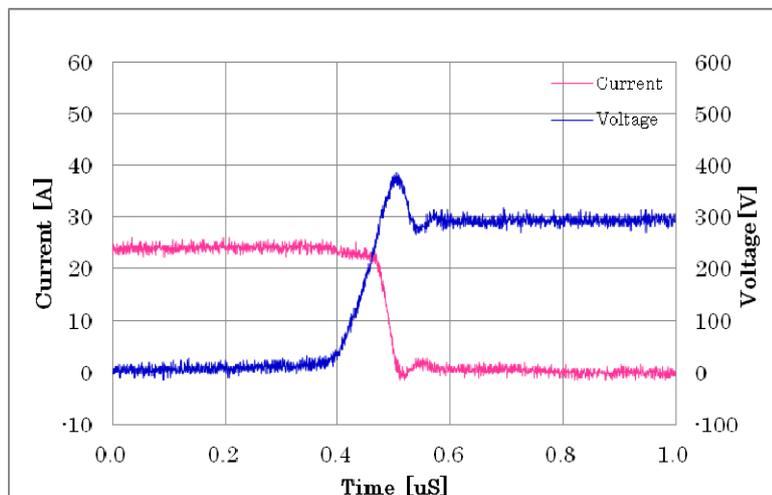

Fig. 15 IGBT Turn-off. Typical turn-off waveform  $T_c = 100^\circ C$ ,  $V_{CC} = 300 V$ ,  $I_c = 25 A$

# STK5F1U3E2D-E

## CB capacitor value calculation for bootstrap circuit

### Calculate condition

Item	Symbol	Value	Unit
Upper side power supply	VBS	15	V
Total gate charge of output power IGBT at 15 V	Qg	0.47	μC
Upper side power supply low voltage protection	UVLO	12	V
Upper side power dissipation	IDmax	400	μA
ON time required for CB voltage to fall from 15 V to UVLO	Ton-max	-	s

### Capacitance calculation formula

CB must not be discharged below to the upper limit of the UVLO - the maximum allowable on-time (Ton-max) of the upper side is calculated as follows :

$$VBS * CB - Qg - IDmax * Ton-max = UVLO * CB$$
$$CB = (Qg + IDmax * Ton-max) / (VD - UVLO)$$

The relationship between Ton-max and CB becomes as follows. CB is recommended to be approximately 3 times the value calculated above. The recommended value of CB is in the range of 1 to 47 μF, however, the value needs to be verified prior to production.

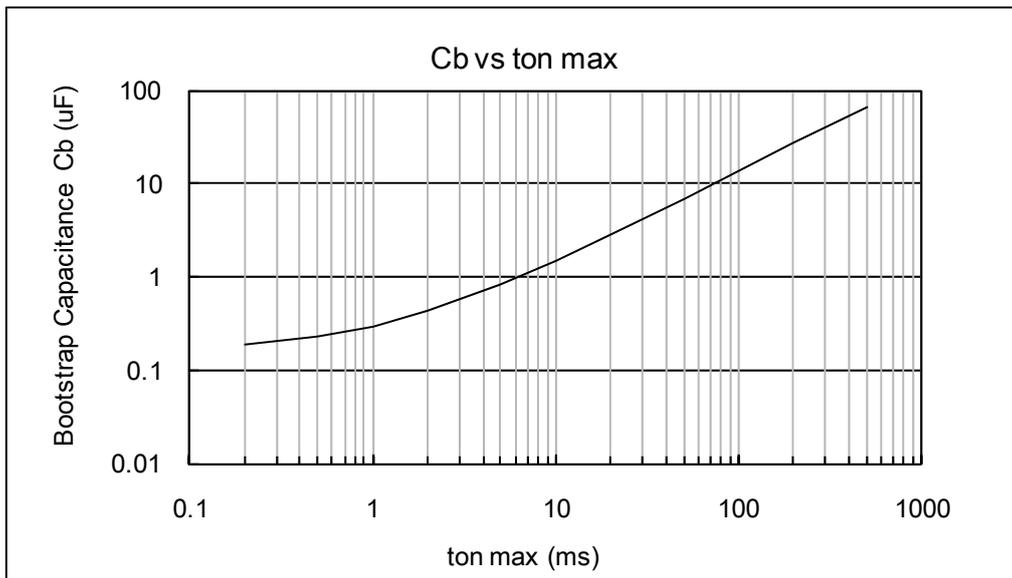

Fig.16 Ton-max vs CB characteristic

# STK5F1U3E2D-E

## PACKAGE DIMENSIONS

unit : mm

TENTATIVE

Missing Pin : 3, 6, 9, 25, 29, 33, 37, 41

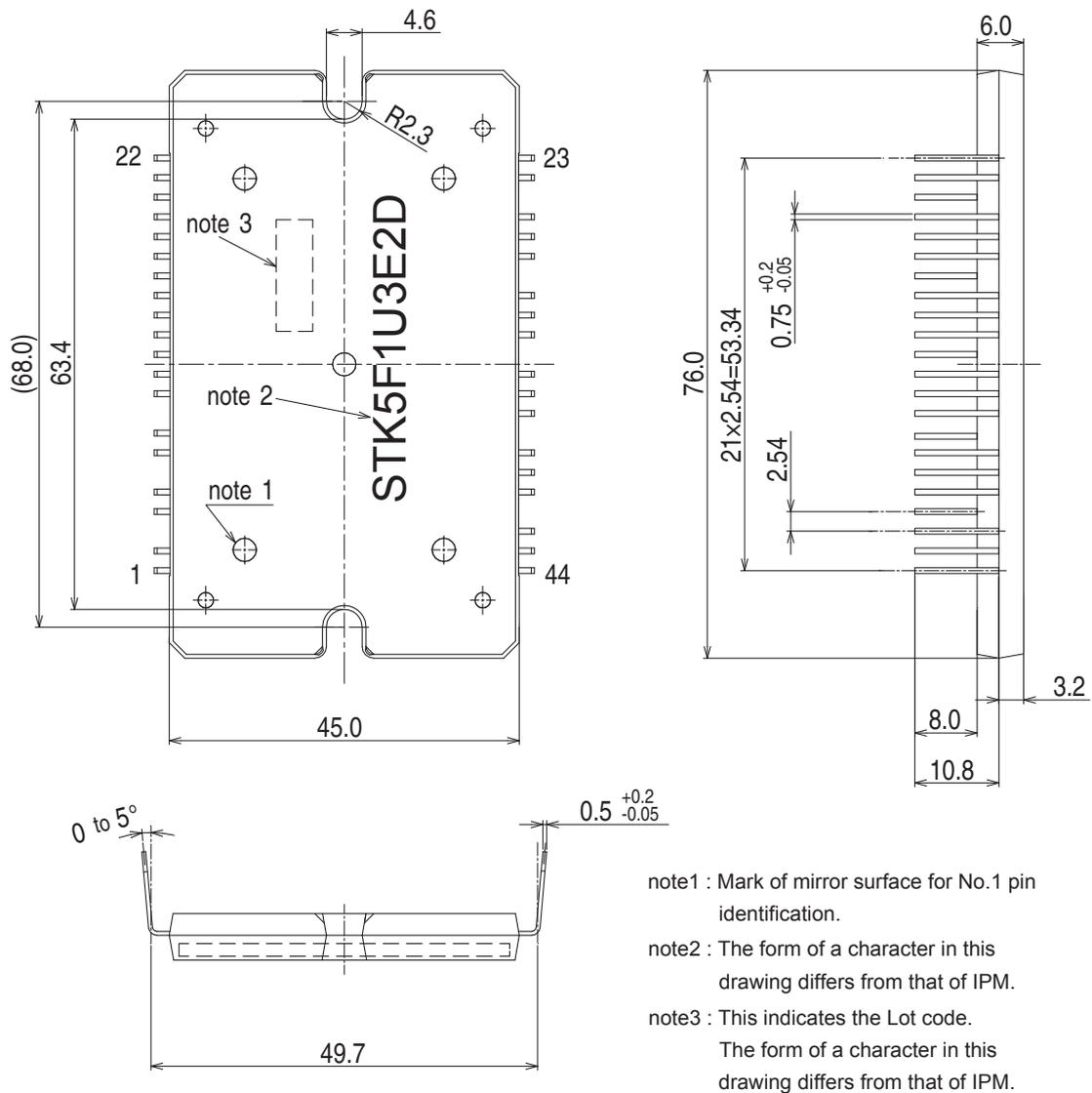

## STK5F1U3E2D-E

### ORDERING INFORMATION

Device	Package	Shipping (Qty / Packing)
STK5F1U3E2D-E	TBD (Pb-Free)	6 / Tube

ON Semiconductor and the ON Semiconductor logo are trademarks of Semiconductor Components Industries, LLC dba ON Semiconductor or its subsidiaries in the United States and/or other countries. ON Semiconductor owns the rights to a number of patents, trademarks, copyrights, trade secrets, and other intellectual property. A listing of ON Semiconductor's product/patent coverage may be accessed at [www.onsemi.com/site/pdf/Patent-Marking.pdf](http://www.onsemi.com/site/pdf/Patent-Marking.pdf). ON Semiconductor reserves the right to make changes without further notice to any products herein. ON Semiconductor makes no warranty, representation or guarantee regarding the suitability of its products for any particular purpose, nor does ON Semiconductor assume any liability arising out of the application or use of any product or circuit, and specifically disclaims any and all liability, including without limitation special, consequential or incidental damages. Buyer is responsible for its products and applications using ON Semiconductor products, including compliance with all laws, regulations and safety requirements or standards, regardless of any support or applications information provided by ON Semiconductor. "Typical" parameters which may be provided in ON Semiconductor data sheets and/or specifications can and do vary in different applications and actual performance may vary over time. All operating parameters, including "Typicals" must be validated for each customer application by customer's technical experts. ON Semiconductor does not convey any license under its patent rights nor the rights of others. ON Semiconductor products are not designed, intended, or authorized for use as a critical component in life support systems or any FDA Class 3 medical devices or medical devices with a same or similar classification in a foreign jurisdiction or any devices intended for implantation in the human body. Should Buyer purchase or use ON Semiconductor products for any such unintended or unauthorized application, Buyer shall indemnify and hold ON Semiconductor and its officers, employees, subsidiaries, affiliates, and distributors harmless against all claims, costs, damages, and expenses, and reasonable attorney fees arising out of, directly or indirectly, any claim of personal injury or death associated with such unintended or unauthorized use, even if such claim alleges that ON Semiconductor was negligent regarding the design or manufacture of the part. ON Semiconductor is an Equal Opportunity/Affirmative Action Employer. This literature is subject to all applicable copyright laws and is not for resale in any manner.