



Chipsmall Limited consists of a professional team with an average of over 10 year of expertise in the distribution of electronic components. Based in Hongkong, we have already established firm and mutual-benefit business relationships with customers from,Europe,America and south Asia,supplying obsolete and hard-to-find components to meet their specific needs.

With the principle of "Quality Parts,Customers Priority,Honest Operation,and Considerate Service",our business mainly focus on the distribution of electronic components. Line cards we deal with include Microchip,ALPS,ROHM,Xilinx,Pulse,ON,Everlight and Freescale. Main products comprise IC,Modules,Potentiometer,IC Socket,Relay,Connector.Our parts cover such applications as commercial,industrial, and automotives areas.

We are looking forward to setting up business relationship with you and hope to provide you with the best service and solution. Let us make a better world for our industry!



## Contact us

Tel: +86-755-8981 8866 Fax: +86-755-8427 6832

Email & Skype: info@chipsmall.com Web: www.chipsmall.com

Address: A1208, Overseas Decoration Building, #122 Zhenhua RD., Futian, Shenzhen, China





**ON Semiconductor®**

<http://onsemi.com>

# STK621-061-E

---

Thick-Film Hybrid IC

## 3-Phase Motor Drive Inverter Hybrid IC

### Overview

This IC is a 3-phase inverter power hybrid IC containing power elements (IGBT and FRD), pre-driver, overcurrent and excessive temperature protection circuit.

### Application

- 3-phase inverter motor drive

### Features

- Integrates power elements (IGBT and FRD), pre-driver, and protective circuit.
- Protective circuits including overcurrent (bus line), excessive temperature and pre-drive low voltage protection are built in.
- Direct input of CMOS level control signals without an insulating circuit (photocoupler, etc) is possible.
- Single power supply drive is possible by using a bootstrap circuit with a built-in IC
- Temperature monitor is possible by the thermistor inside the IC
- Built-in simultaneous upper/lower ON prevention circuit to prevent arm shorting through simultaneous ON input for the upper and lower side transistors.  
(Dead time is required for preventing shorting due to switching delay.)
- SIP (The single in-line package) of the transfer full mold structure.

# STK621-061-E

## Specifications

### Absolute Maximum Ratings at $T_c = 25^\circ\text{C}$

Parameter	Symbol	Conditions	Ratings	unit
Supply voltage	$V_{CC}$	+ - -, surge < 500V *1	450	V
Collector-emitter voltage	$V_{CE}$	+ - U (V, W) or U (V, W) - -	600	V
Output current	$I_O$	+, -, U, V, W terminal current	$\pm 30$	A
Output peak current	$I_{op}$	+, -, U, V, W terminal current $PW = 100\mu\text{s}$	$\pm 45$	A
Pre-driver supply voltage	VD1, 2, 3, 4	VB1 - U, VB2 - V, VB3 - W, $V_{DD} - V_{SS}$ *2	20	V
Input signal voltage	$V_{IN}$	HIN1, 2, 3, LIN1, 2, 3 terminal	0 to 7	V
FAULT terminal voltage	VFAULT	FAULT terminal	20	V
Maximum loss	$P_d$	Per 1 channel	49	W
Junction temperature	$T_j$	IGBT, FRD junction temperature	150	$^\circ\text{C}$
Storage temperature	$T_{stg}$		-40 to +125	$^\circ\text{C}$
Operating temperature	$T_C$	H-IC case temperature	-20 to +100	$^\circ\text{C}$
Tightening torque		A screw part at use M4 type screw *3	1.17	N•m
Withstand voltage	Vis	50Hz sine wave AC 1 minute *4	2000	VRMS

In the case without the instruction, the voltage standard is - terminal =  $V_{SS}$  terminal voltage.

\*1 Surge voltage developed by the switching operation due to the wiring inductance between the + and - terminals.

\*2 VD1 = between VB1-U, VD2 = VB2-V, VD3 = VB3-W, VB4 =  $V_{DD} - V_{SS}$ , terminal voltage.

\*3 Flatness of the heat-sink should be lower than 0.25mm.

\*4 The test condition is AC 2500V, 1 second.

Stresses exceeding Maximum Ratings may damage the device. Maximum Ratings are stress ratings only. Functional operation above the Recommended Operating Conditions is not implied. Extended exposure to stresses above the Recommended Operating Conditions may affect device reliability.

### Electrical Characteristics at $T_c=25^\circ\text{C}$ , $V_D=15\text{V}$

Parameter	Symbol	Conditions	Test Circuit	Ratings			unit
				min	typ	max	
Power output part							
Collector-to-emitter cut-off current	$I_{CE}$	$V_{CE} = 600\text{V}$	Fig.1			0.5	mA
Boot-strap diode reverse current	$I_R$ (BD)	$V_R$ (BD) = 600V	Fig.1			0.5	mA
Collector-to-emitter saturation voltage	$V_{CE}$ (SAT)	$I_O = 15\text{A}$	Upper side	Fig.2		1.8	V
			Lower side			2.0	V
Diode forward voltage	$V_F$	$I_O = -15\text{A}$	Upper side	Fig.3		1.7	V
			Lower side			1.9	V
Junction-to-substrate thermal resistance	$\theta_{j-c}$ (T)	IGBT				2.1	$^\circ\text{C/W}$
	$\theta_{j-c}$ (D)	FWD				2.5	$^\circ\text{C/W}$
Control (Pre-driver) part							
Pre-drive power supply consumption electric current	$I_D$	$VD1, 2, 3 = 15\text{V}$	Fig.4		0.07	0.4	mA
		$VD4 = 15\text{V}$			2	5	
Input ON voltage	$V_{IH}$	Output ON				0.8	V
Input OFF voltage	$V_{IL}$	Output OFF		3.0			V
Protection part							
Excessive temperature	TSD	The substrate surface		100		120	$^\circ\text{C}$
Overcurrent protection electric current	ISD	$PW = 100\mu\text{s}$	Fig.5	46		58	A
Pre-drive low voltage protection	UVLO			10		12	V
Fault terminal input electric current	IOSD	$V_{Fault} = 0.1\text{V}$			0.5		mA
Fault clearness delay time	FLTCLR	After each protection operation ending		18		80	ms
Board Temperature Mounting resistance	$R_t$	Resistance between the Fault and $V_{SS}$ terminals		90		110	$\text{k}\Omega$
Switching time							
	$t_{ON}$	$I_O = 15\text{A}$ , Inductive load	Fig.6		0.8		$\mu\text{s}$
	$t_{OFF}$				1.0		$\mu\text{s}$
Electric current output signal level	ISO	$I_O = 15\text{A}$			0.141		V

In the case without the instruction, the voltage standard is - terminal =  $V_{SS}$  terminal voltage.

## Notes

1. Input ON voltage indicates a value to turn on output stage IGBT.  
 Input OFF voltage indicates a value to turn off output stage IGBT.  
 At the time of output ON, set the input signal voltage 0V to  $V_{IH}$  (MAX).  
 At the time of output OFF, set the input signal voltage  $V_{IL}$  (MIN) to 5V.
  
2. When the internal protection circuit operates, there is a Fault signal ON (When the Fault terminal is low level, Fault signal is ON state : output form is open DRAIN) but the Fault signal doesn't latch.  
 After protection operation ends, it returns automatically within about 18ms to 80ms and resumes operation beginning condition. So, after Fault signal detection, set OFF (HIGH) to all input signals at once.  
 However, the operation of pre-drive power supply low voltage protection (UVLO: it has a hysteresis about 0.3V) is as follows.  
 Upper side → There is no Fault signal output, but it does a corresponding gate signal OFF.  
     Incidentally, it returns to the regular operation when recovering to the normal voltage, but the latch continues among input signal ON (LOW).  
 Lower side → It outputs Fault signal with gate signal OFF.  
     However, it is different from the protection operation of upper side, it is automatically resets about 18ms to 80ms later and resumes operation beginning condition when recovering to normal voltage.  
     (The protection operation doesn't latch by the input signal.)
  
3. When assembling the hybrid IC on the heat sink with M4 type screw, tightening torque range is 0.79N•m to 1.17N•m.  
 Flatness of the heat-sink should be lower than 0.25mm.
  
4. The pre-drive low voltage protection is the feature to protect a device when the pre-driver supply voltage declines with the operating malfunction. As for the pre-driver supply voltage decline in case of operation beginning, and so on, we request confirmation in the set.

## Package Dimensions

unit:mm (typ)

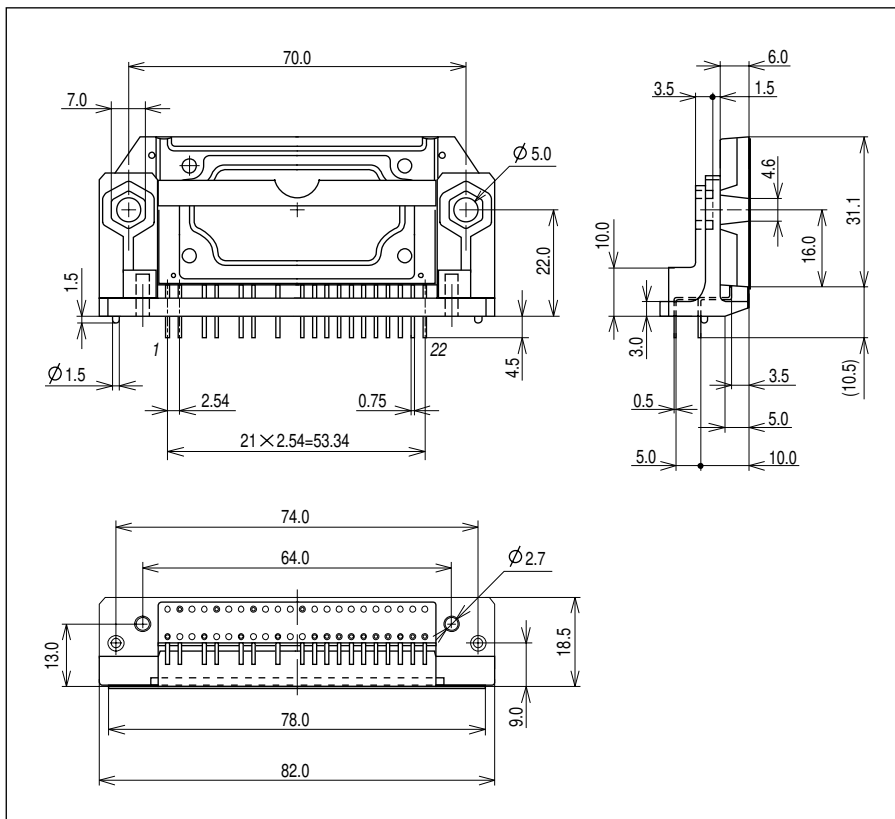

Internal Equivalent Circuit Diagram

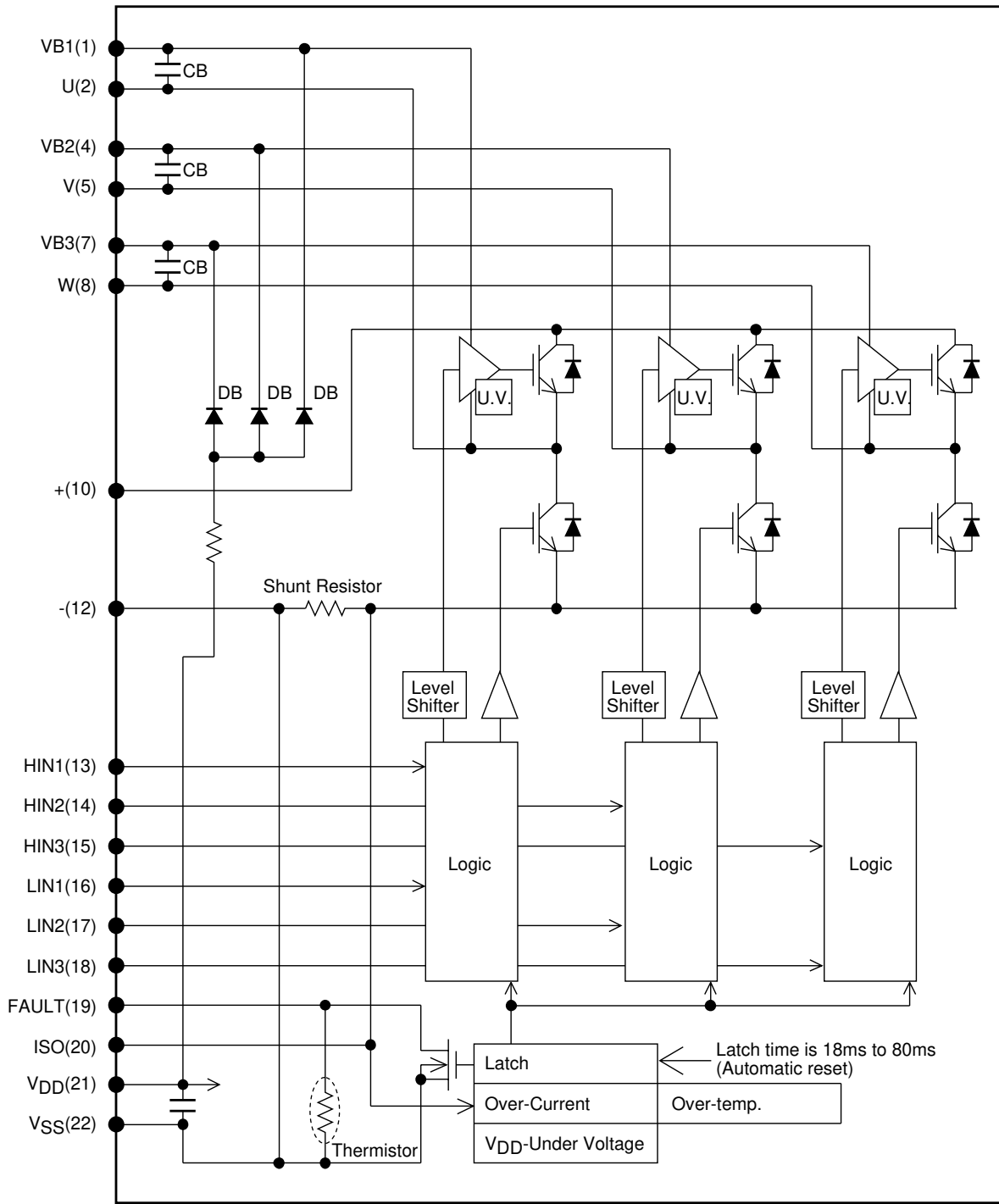

Test Circuit

Fig 1:  $I_{CE}$

	U+	V+	W+	U-	V-	W-
M	10	10	10	2	5	8
N	2	5	8	12	12	12

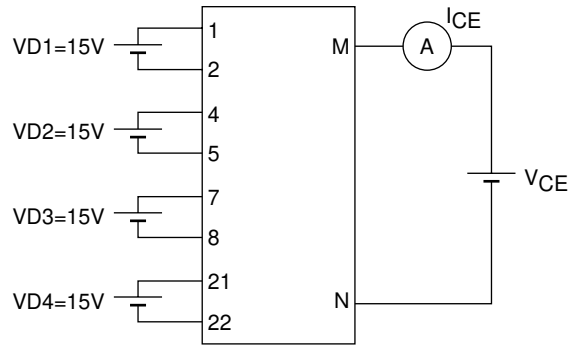

Fig 2:  $V_{CE(SAT)}$

	U+	V+	W+	U-	V-	W-
M	10	10	10	2	5	8
N	2	5	8	12	12	12
m	13	14	15	16	17	18

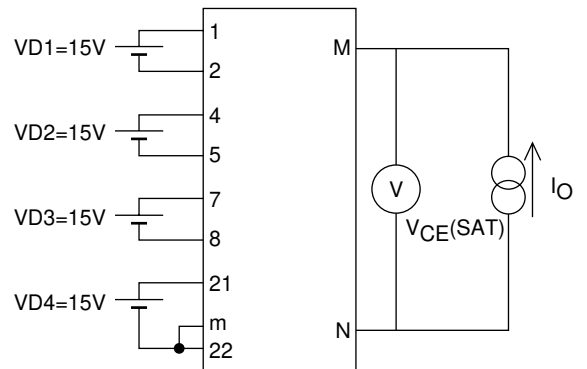

Fig 3:  $V_F$

	U+	V+	W+	U-	V-	W-
M	10	10	10	2	5	8
N	2	5	8	12	12	12

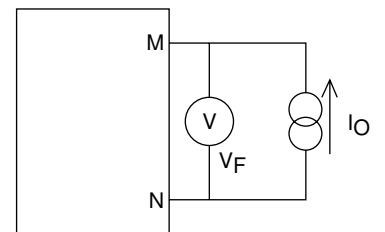

Fig 4:  $I_D$

	VD1	VD2	VD3	VD4
m	1	4	7	21
n	2	5	8	22

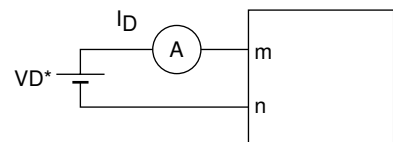

Fig 5: ISD

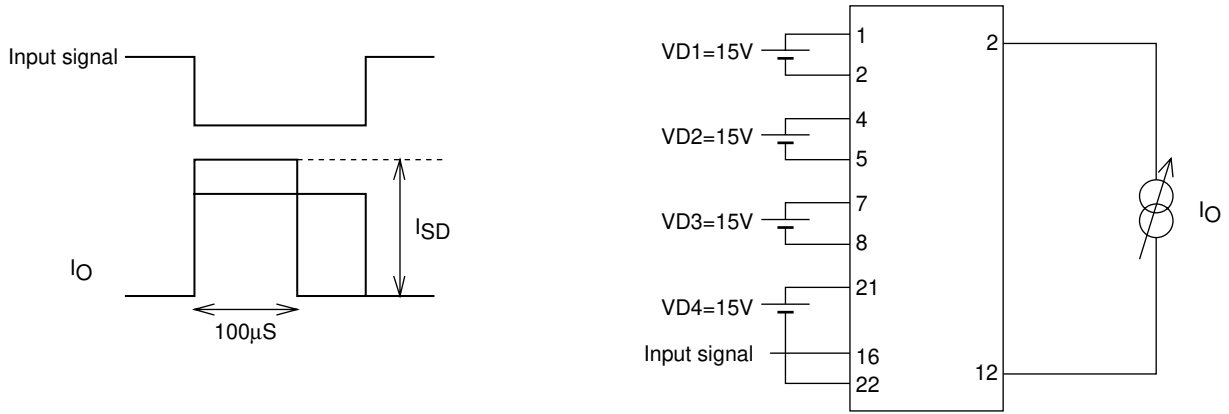
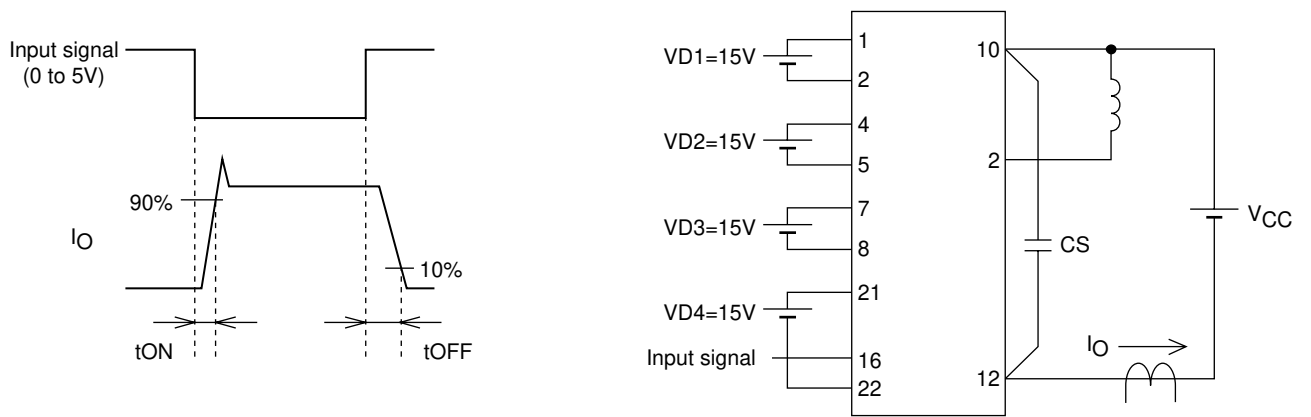
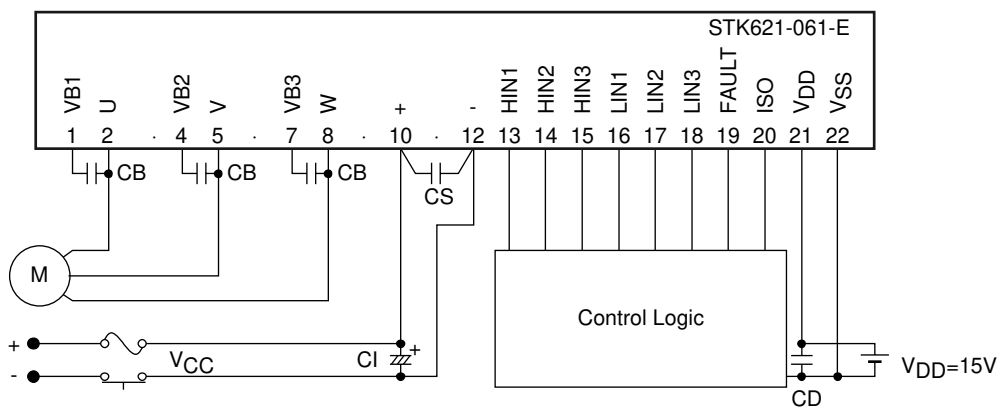

Fig 6: Switching Time



Example of the application circuit



# STK621-061-E

## Recommendation Operating Conditions

Parameter	Symbol	Conditions	min	typ	max	unit
Supply voltage	$V_{CC}$	+ - -	0	280	400	V
Pre-driver supply voltage	VD1, 2, 3	VB1 - U, VB2 - V, VB3 - W	12.5	15	17.5	V
	VD4	$V_{DD} - V_{SS}^{*1}$	13.5	15	16.5	
Input ON voltage	$V_{IN(ON)}$	HIN1, HIN2, HIN3,	0		0.3	V
Input OFF voltage	$V_{IN(OFF)}$	LIN1, LIN2, LIN3 Terminal				
PWM frequency	fPWM		1		20	kHz
Dead time	DT	Upper/lower input signal downtime	2			$\mu$ s
Tightening torque	MT	'M4' Type Screw	0.79		1.17	N•m

\*1. Pre-driver power supply (VD4 = 15±1.5V) must have the capacity of  $I_O = 20\text{mA}$  (DC), 0.5A (Peak).

## Usage Precaution

- Single power supply drive is possible by using a bootstrap circuit with a built-in IC.  
(When not using bootstrap circuit, each upper side pre-drive power supply needs an independent power supply. Externally set.)  
Also, the upper side power supply voltage sometimes declines by the way of controlling. Confirm it.
- Because the jump voltage which is accompanied by the vibration in case of switching operation occurs by the influence of the floating inductance of the wiring of the outer power supply which is connected with of the + terminal and the -terminal, restrains and spares serge voltage being as the connection of the snubber circuit (Capacitor/CS/about 0.1 - 10 $\mu$ F) for the voltage absorption with the neighborhood as possible between + and the - terminal, and so on, with making a wiring length (among the terminals each from CI) short and making a wiring inductance small.
- ISO terminal (20pin) is for the electric current monitor. Be careful, because the overcurrent protection does not operate when short-circuiting in the ISO terminal and the  $V_{SS}$  terminal.
- Output form of the FAULT terminal is open DRAIN (it is operating as FAULT when becoming LOW).  
When the pull up with the resistance, use above 5.6k $\Omega$ .
- Zener diode with 5V (5.0 - 5.4V) is connected with the inside of the signal input terminal. When inputting the voltage which exceeds 5V, connect resistor to between the side of the power and the signal input terminal, for the input current of the signal input terminal become equal to or less than 0.5mA.  
This resistor is effective with the noise absorption of the signal terminal, too.
- The overcurrent protection feature operates only when it is possible to do a circuit control normally. For the safety, put a fuse, and so on in the  $V_{CC}$  line.
- Because the IC sometimes destroys and bursts when motor connection terminal (2pin, 5pin, 8pin) becomes open while the motor turns, especially, be careful of the connection ( the soldering condition ) of this terminal.
- If - terminal and  $V_{SS}$  terminal are short-circuited, since an over-current protection (ISD) value will become lower than the inside setting value of HIC, please do not connect externally.  
(-terminal and  $V_{SS}$  terminal are connected inside HIC)

This data shows the example of the application circuit, does not guarantee a design as the mass production set.



ON Semiconductor and the ON logo are registered trademarks of Semiconductor Components Industries, LLC (SCILLC). SCILLC owns the rights to a number of patents, trademarks, copyrights, trade secrets, and other intellectual property. A listing of SCILLC's product/patent coverage may be accessed at [www.onsemi.com/site/pdf/Patent-Marking.pdf](http://www.onsemi.com/site/pdf/Patent-Marking.pdf). SCILLC reserves the right to make changes without further notice to any products herein. SCILLC makes no warranty, representation or guarantee regarding the suitability of its products for any particular purpose, nor does SCILLC assume any liability arising out of the application or use of any product or circuit, and specifically disclaims any and all liability, including without limitation special, consequential or incidental damages. "Typical" parameters which may be provided in SCILLC data sheets and/or specifications can and do vary in different applications and actual performance may vary over time. All operating parameters, including "Typicals" must be validated for each customer application by customer's technical experts. SCILLC does not convey any license under its patent rights nor the rights of others. SCILLC products are not designed, intended, or authorized for use as components in systems intended for surgical implant into the body, or other applications intended to support or sustain life, or for any other application in which the failure of the SCILLC product could create a situation where personal injury or death may occur. Should Buyer purchase or use SCILLC products for any such unintended or unauthorized application, Buyer shall indemnify and hold SCILLC and its officers, employees, subsidiaries, affiliates, and distributors harmless against all claims, costs, damages, and expenses, and reasonable attorney fees arising out of, directly or indirectly, any claim of personal injury or death associated with such unintended or unauthorized use, even if such claim alleges that SCILLC was negligent regarding the design or manufacture of the part. SCILLC is an Equal Opportunity/Affirmative Action Employer. This literature is subject to all applicable copyright laws and is not for resale in any manner.