



Chipsmall Limited consists of a professional team with an average of over 10 year of expertise in the distribution of electronic components. Based in Hongkong, we have already established firm and mutual-benefit business relationships with customers from,Europe,America and south Asia,supplying obsolete and hard-to-find components to meet their specific needs.

With the principle of “Quality Parts,Customers Priority,Honest Operation,and Considerate Service”,our business mainly focus on the distribution of electronic components. Line cards we deal with include Microchip,ALPS,ROHM,Xilinx,Pulse,ON,Everlight and Freescale. Main products comprise IC,Modules,Potentiometer,IC Socket,Relay,Connector.Our parts cover such applications as commercial,industrial, and automotives areas.

We are looking forward to setting up business relationship with you and hope to provide you with the best service and solution. Let us make a better world for our industry!



## Contact us

Tel: +86-755-8981 8866 Fax: +86-755-8427 6832

Email & Skype: info@chipsmall.com Web: www.chipsmall.com

Address: A1208, Overseas Decoration Building, #122 Zhenhua RD., Futian, Shenzhen, China





**ON Semiconductor®**

<http://onsemi.com>

# STK760-216-E

---

Thick-Film Hybrid IC

## Single-phase rectification Active Converter Hybrid IC

### Overview

This IC is average current control type Active Converter Hybrid IC for power factor improvement of single-phase AC power supply, that containing power devices of step-up active converter, control IC over-current and over-voltage protection circuits.

### Applications

- Single-phase rectification active filter for power rectification for air conditioners and general-purpose inverters.

### Features

- Power switching device for active converter is adopting IGBT.
- Soft start functions and the over current, the over voltage, and the low-voltage are including as protection circuit
- Capable of controlling ON/OFF by logic level input signal.
- Output voltage changeability functions by control signal.

# STK760-216-E

## Specifications

**Absolute Maximum Ratings** at  $T_a = 25^\circ\text{C}$

Parameter		Symbol	Conditions	Ratings	unit
IGBT (TR1+TR2)	Collector-emitter voltage	VCE		600	V
	Repetitive peak collector current	ICP	*1	300	A
	Collector current	IC		148	A
	Power dissipation	PC1		223	W
FRD1 (D1)	Diode reverse voltage	VRM		600	V
	Repetitive peak forward current	IF1P	*1	220	A
	Diode forward current	IF1		73	A
	Power dissipation	PD1		150	W
FRD2 (D2)	Repetitive peak forward current	IF2P	*1	15	A
	Diode forward current	IF2		7	A
	Power dissipation	PD2		13	W
Supply voltage ( $V_{CC-GND}$ )		$V_{CC}$		20	V
Signal pin input voltage	Pin 1	VBOP		-0.3 to 9.0	V
	Pin 7	VIS		-10 to 0.3	
	Pin 8	VCOMP		-0.3 to 6.5	
	Pin 12	VFB			
	Pin 13	VOVP			
	Pin 4	VONF		-0.3 to $V_{CC}$	
	Pin 10	Vctl			
Maximum input AC voltage		VAC	Single-phase Full-rectified	264	V
Maximum output voltage		$V_O$	Under the Application condition ( $V_{AC}=200V$ )	450	V
Maximum output power		$W_o$		8	kW
Input AC current (normal condition)		$I_{IN}$		40	Arms
Junction temperature		$T_J$		150	$^\circ\text{C}$
Operating case temperature		$T_c$	HIC case temperature *2	-20 to +100	$^\circ\text{C}$
Storage temperature		$T_{stg}$		-40 to +125	$^\circ\text{C}$
Tightening torque			A screw part *3	1.17	N•m
Withstand voltage		VINS	50Hz sine wave AC 1minute *4	2000	VRMS

[Note]

\*1: Duty ratio  $D = 0.1$ ,  $t_p = 1\text{ms}$

\*2: Measure point is between 5mm to center of back.

\*3: Torque should be set within 0.79 to 1.17N•m. Flatness of the heat-sink should be lower than 0.2mm.

\*4: The test condition: AC2500V, 1 second.

Stresses exceeding Maximum Ratings may damage the device. Maximum Ratings are stress ratings only. Functional operation above the Recommended Operating Conditions is not implied. Extended exposure to stresses above the Recommended Operating Conditions may affect device reliability.

# STK760-216-E

**Electrical Characteristics** at  $T_c = 25^\circ\text{C}$ ,  $V_{CC} = 15.0\text{V}$ : Unless otherwise noted

Parameter	Symbol	Conditions	Test circuit	Ratings			unit
				min	typ	max	
Power output part							
Collector-emitter leak current (IGBT)	$I_{CES}$	$V_{CE} = 600\text{V}$	Fig.1			200	$\mu\text{A}$
Collector-emitter saturation voltage (IGBT)	$V_{CE(sat)}$	$I_C = 50\text{A}$	Fig.2		1.2	1.8	V
Diode reverse current (FRD1)	$I_R$	$V_R = 600\text{V}$	Fig.1			200	$\mu\text{A}$
Diode forward voltage (FRD1)	$V_{F1}$	$I_F = 50\text{A}$	Fig.3		1.8	2.4	V
Diode forward voltage (FRD2)	$V_{F2}$	$I_F = 5\text{A}$	Fig.3		2.5	3.5	V
Junction to case thermal resistance	$\theta_{j-c1}$	IGBT (TR1+TR2)			0.56		$^\circ\text{C/W}$
	$\theta_{j-c2}$	FRD1 (D2+D3)			0.83		$^\circ\text{C/W}$
	$\theta_{j-c3}$	FRD2 (D4)			9.0		$^\circ\text{C/W}$
Control IC part							
Control IC input current	$I_{CC(ON)}$	$V_{CC} = 15\text{V}$ , $V_{ONF} = 5\text{V}$	Fig.4		14	20	mA
	$I_{CC(OFF)}$	$V_{CC} = 15\text{V}$ , $V_{ONF} = 0\text{V}$			2.5	5	
Oscillation frequency	$f_{OSC}$	$V_{CC} = 15\text{V}$ , $V_{ONF} = 5\text{V}$	Fig.4	19.5	22.0	24.5	kHz
Open loop protection threshold voltage	VOLP			0.8	0.95	1.1	V
Error-amp reference voltage	$V_{ref}$		Fig.5	4.88	5.0	5.12	V
Peak current protection threshold voltage	$V_{IS(PK)}$			-0.58	-0.5	-0.42	V
Over voltage protection threshold voltage	$V_{OVP(ON)}$		Fig.6	5.095	5.3	5.51	V
Brown-out protection threshold voltage	$V_{BOP(ON)}$			0.66	0.76	0.86	V
Brown-out protection enable voltage	$V_{BOP(EN)}$			1.46	1.56	1.66	V
ON/OFF threshold voltage	$V_{THON}$	$V_{CC} = 15\text{V}$	Fig.7	3.0			V
	$V_{THOFF}$					0.5	V
Start-up $V_{CC}$ voltage	$V_{CC(ON)}$	$V_{ONF} = 5\text{V}$	Fig.8	12.4	13.25	14.1	V
Shut-down $V_{CC}$ voltage	$V_{CC(OFF)}$			9.4	10.0	10.7	V
Substrate temperature monitor resistance	RTH	Resistance between VTH1-VTH2	Fig.3	90	100	110	$\text{k}\Omega$
Application circuit : $V_{AC} = 200\text{V}$ , $V_O = 380\text{V}$ ( $V_{ctl} = 1.507\text{V}$ )							
Output voltage	$V_O$	$W_o = 2\text{kW}$	Fig.9	366	380	394	V
Power Factor	$\cos\phi$	$W_o = 400\text{W}$		0.98	0.99		
		$W_o = 2\text{kW}$		0.99	0.995	1.0	

Package Dimensions

unit:mm (typ)

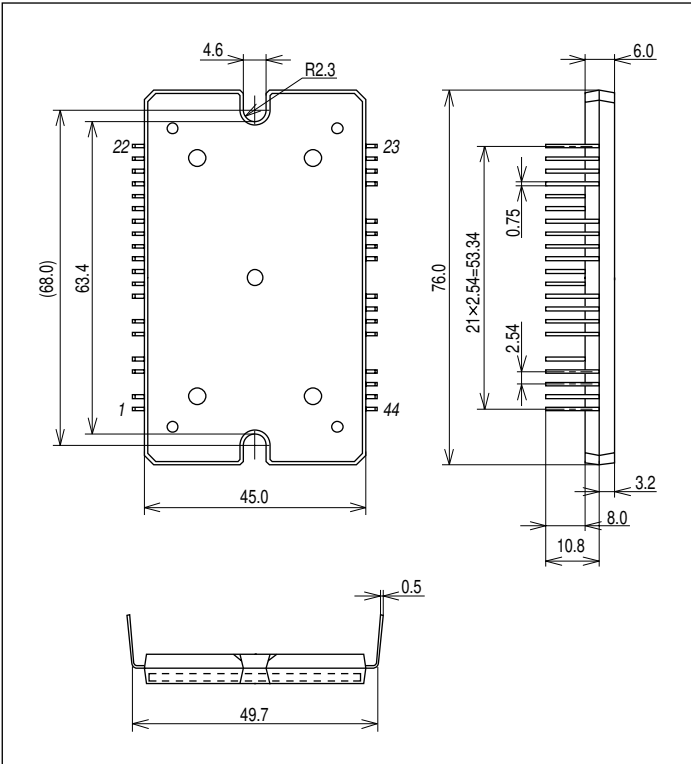

IGBT (TR1+TR2), FRD1 (D2+D3) & FRD2 (D4) vs. Temperature Derating ( $T_a = 25^\circ\text{C}$ )

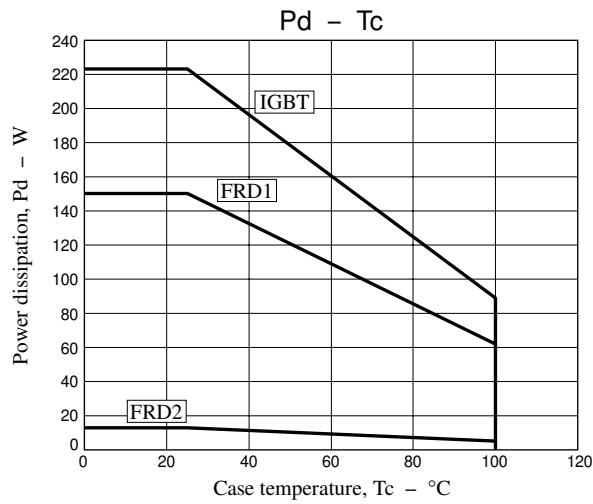

Block Diagram

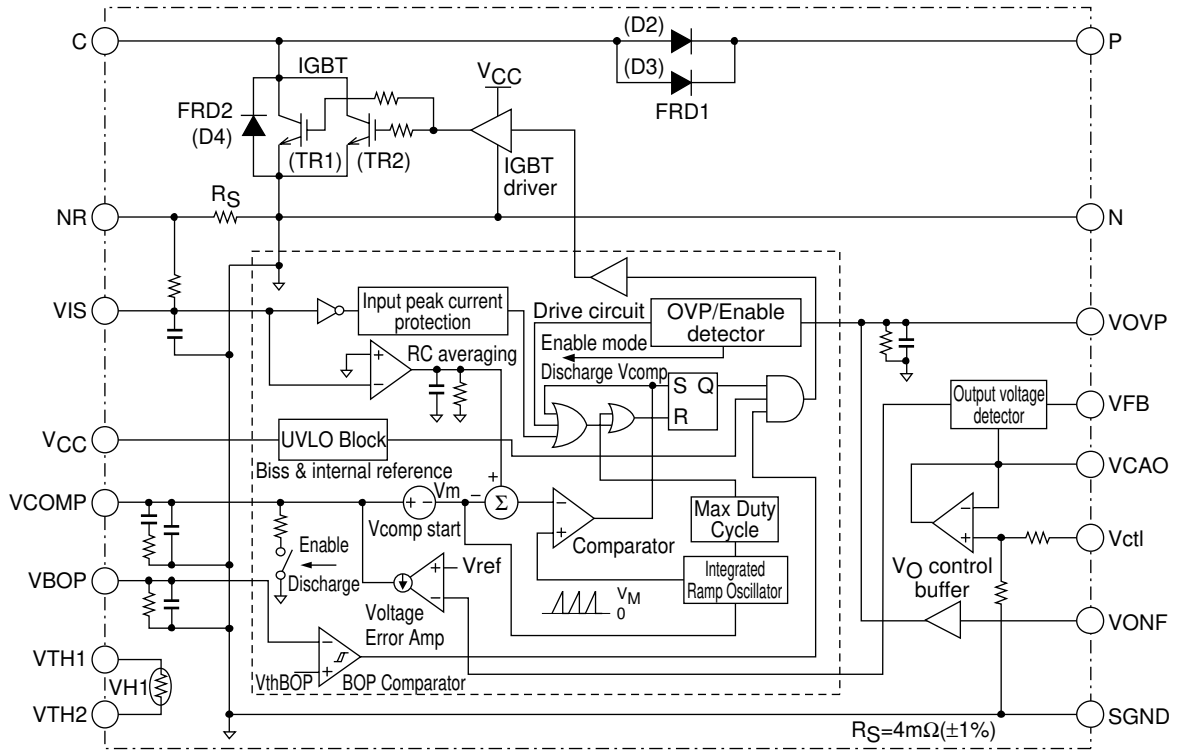

Explanation of Terminal

Terminal No.	Symbol	Explanation
1	VBOP	Brown-out fault detection terminal
2	VCC	Control IC power supply input
3	-	An empty terminal
4	VONF	ON/OFF control terminal
5	GND	Signal GND
6	-	An empty terminal
7	VIS	Current detection terminal
8	VCOMP	Phase compensation terminal (Voltage error amplifier out)
9	-	An empty terminal
10	Vctl	Output voltage control signal input
11	VCAO	Output voltage control amplifier output
12	VFB	Output voltage feed back terminal
13	VOVP	Over voltage protection terminal
14	VTH1	Terminal of thermistor TH1
15	VTH2	Terminal of thermistor TH1
16 to 22	-	A dummy terminal
23 to 26	P	Output (+) terminal of PFC
27, 28	-	An empty terminal
29 to 32	C	IGBT (TR1+TR2) Collector
33,34	-	An empty terminal
35 to 38	N	Output (-) terminal of PFC
39, 40	-	An empty terminal
41 to 44	NR	Input current return terminal

Test Circuit -1

(1)  $I_{CES}$ ,  $I_R$

	IGBT	FRD1
A	29, 30, 31, 32	23, 24, 25, 26
B	35, 36, 37, 38	29, 30, 31, 32

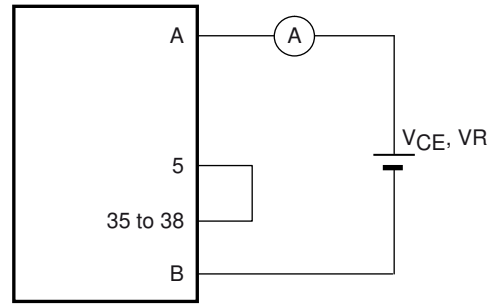

(Fig.1)

(2)  $V_{CE(sat)}$  (Test by Pulse)

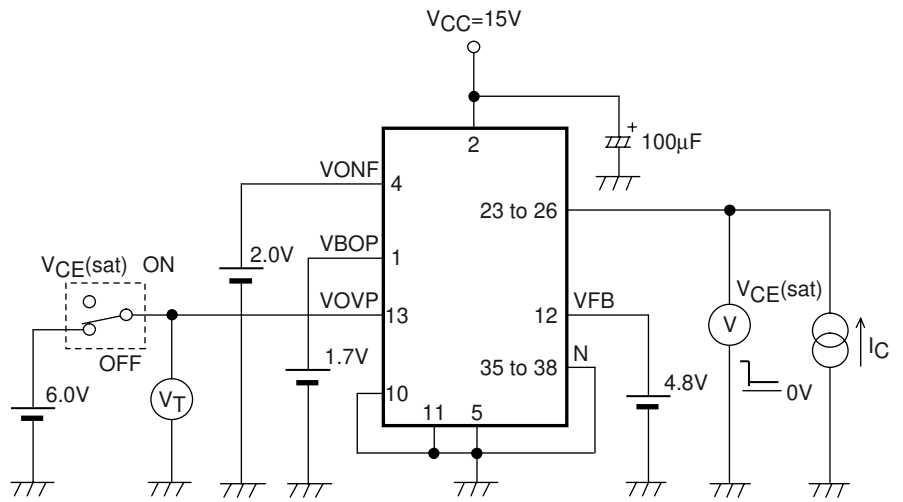

(Fig.2)

(3)  $V_{F1}$ ,  $V_{F2}$  (Test by Pulse),  $R_{TH}$

	FRD1	FRD2
A	29, 30, 31, 32	35, 36, 37, 38
B	23, 24, 25, 26	29, 30, 31, 32

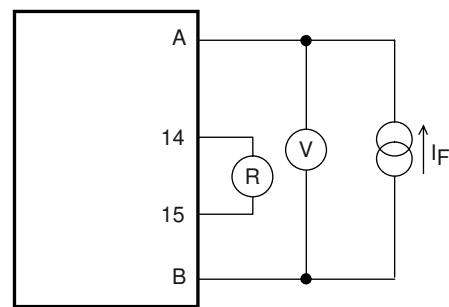

(Fig.3)

Test Circuit -2

(4)  $I_{CC(ON)}/I_{CC(OFF)}$ , VOLP,  $f_{OSC}$

$I_{CC}, f_{OSC}$	VOLP
VFB = 1.1V	VONF = 5.0V

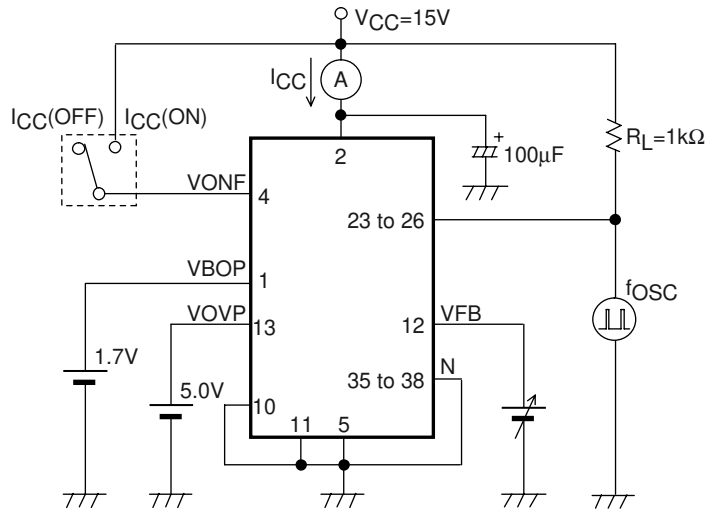

(Fig.4)

(5) Vref, VIS(PK)

Vref	VIS(PK)
VIS = -0.6V	VFB = 4.8V

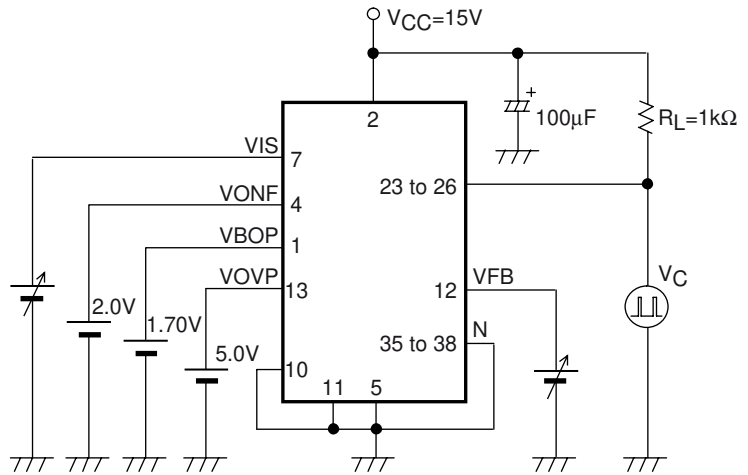

(Fig.5)

(6) VOVP(ON), VBOP(ON)

VOVP(ON)	VBOP(ON)
VBOP = 1.70V	VOVP = 5.0V

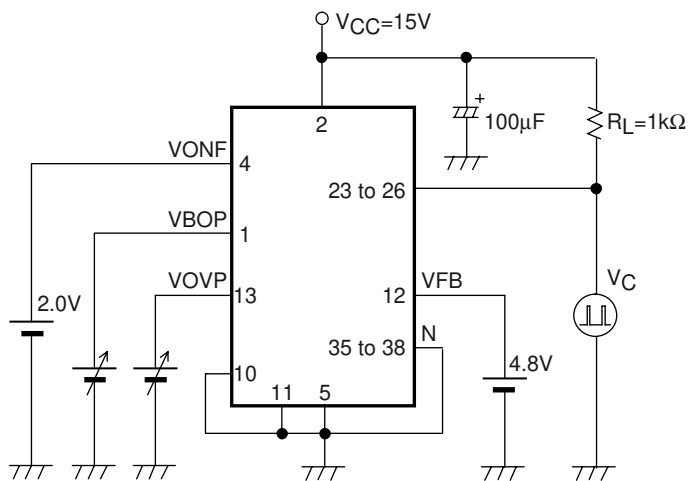

(Fig.6)



Test Circuit -3

(7) VTHON, VTHOFF

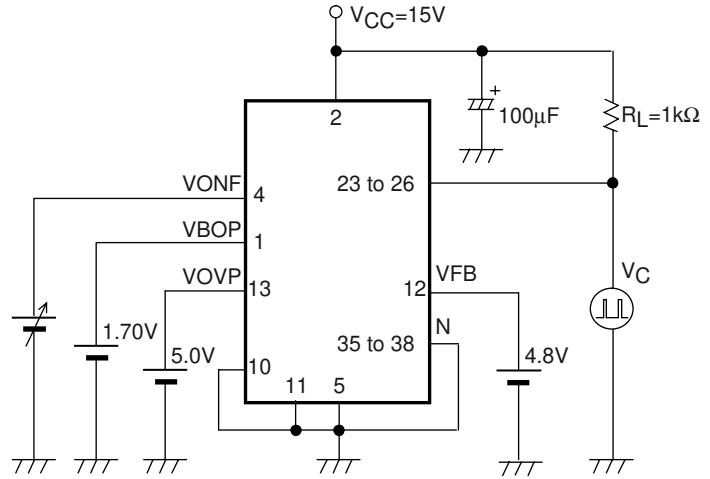

(Fig.7)

(8) VCC(ON), VCC(OFF)

VCC(ON)	VCC(OFF)
Vc-ON	Vc-OFF

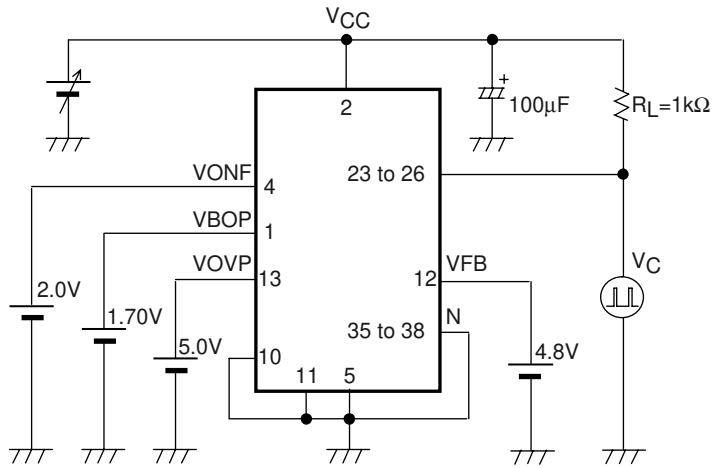

(Fig.8)

(9) Power Factor (COSφ)

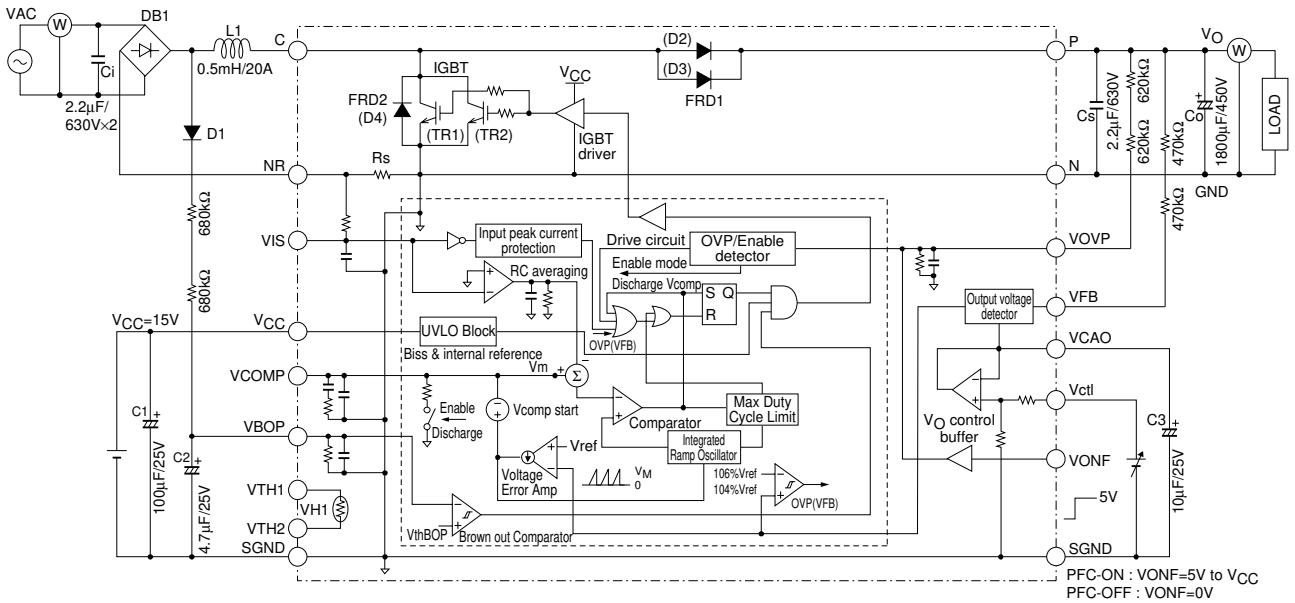

(Fig.9)

Application Circuit

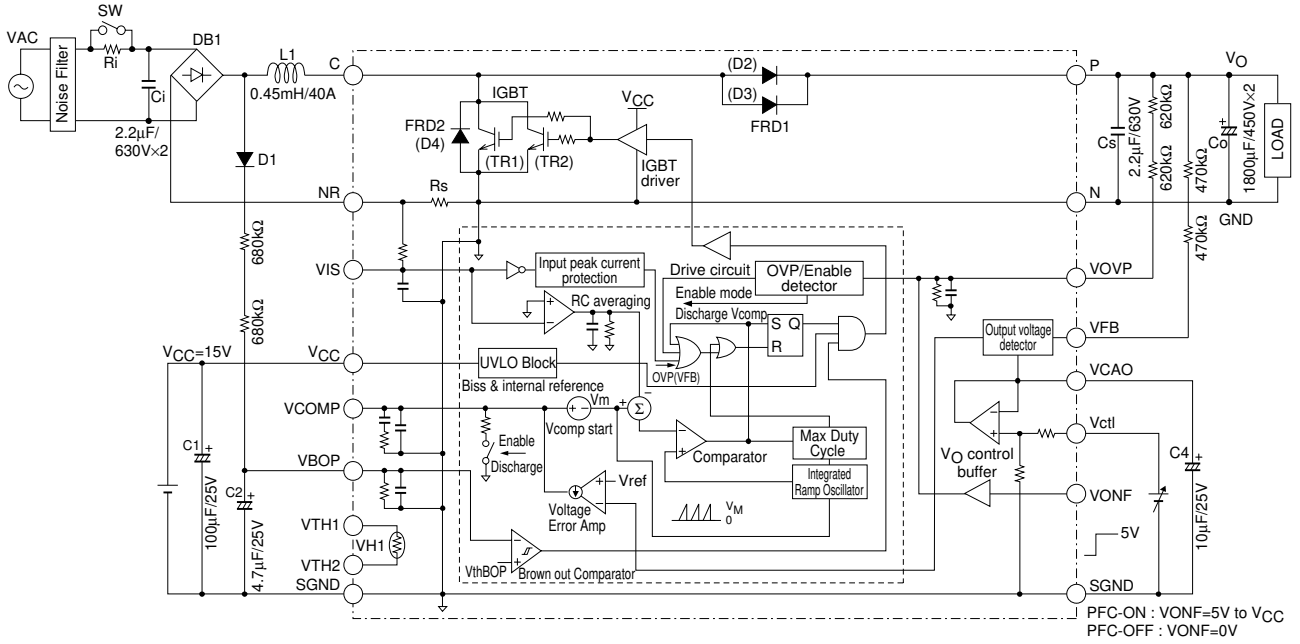

Recommended Condition

Parameter	Symbol	Conditions	Ratings	unit
AC Voltage	VAC	50/60Hz	170 to 264	Vrms
Output voltage	VO		$VAC \times \sqrt{2} + (10 \text{ to } 15) \leq 450$	V
Over-voltage detection voltage	VOV		$VO_{UT} + (10 \text{ to } 20)$	V
Control IC supply voltage	VCC	VCC-GND	14.5 to 17.0	V
Inductor	L1		0.45	mH
Input film capacitor	Ci		$4.4 \leq Ci$	$\mu F$
Output film capacitor	Cs		$4.4 \leq Cs$	$\mu F$
Output electrolytic capacitor	Co		$3600 \leq Co$	$\mu F$

Output Voltage Control

Output voltage control signal Vctl sets referring to the Vctl-VO characteristic of the figure below.

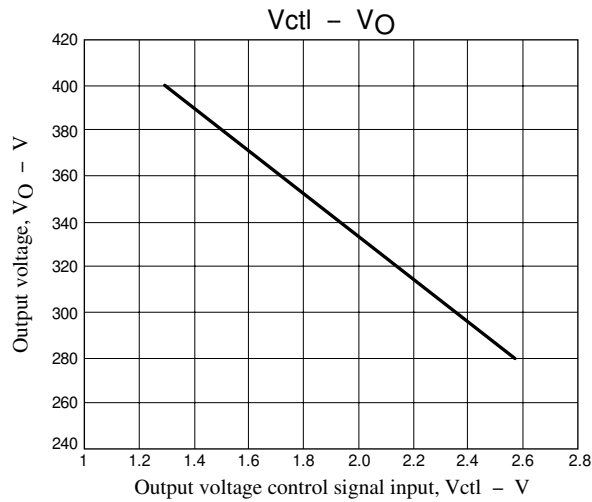

**Timing Chart**

Even if power supply and signal at any timing are input, this IC is not destroyed. However, soft start circuit doesn't operate when  $V_{IN}$  (DC) is input at the timing of Figure 11 and 12. Therefore, overcurrent protection circuit will operate, and audio frequency noise from coil may generate. Please turn on ON/OFF or  $V_{CC}$  after  $V_{IN}$ (DC) to avoid this.

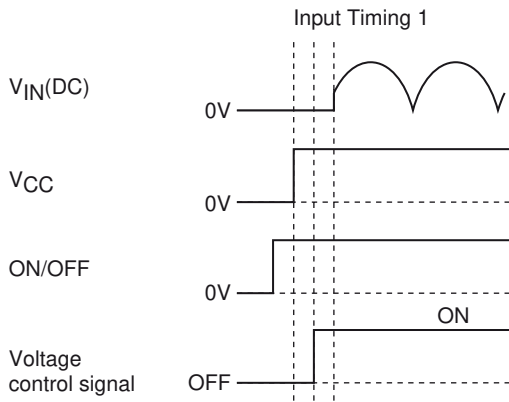

<Fig.11>

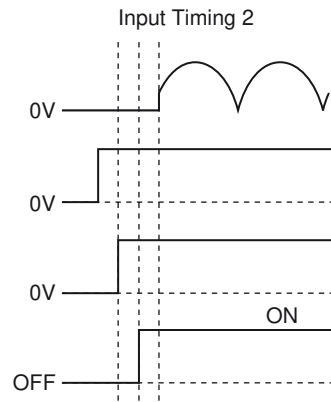

<Fig.12>

**The built-in thermistor resistance temperature characteristic**

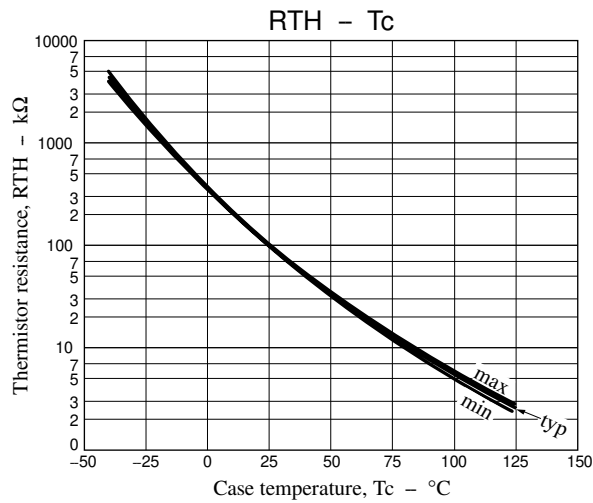

ON Semiconductor and the ON logo are registered trademarks of Semiconductor Components Industries, LLC (SCILLC). SCILLC owns the rights to a number of patents, trademarks, copyrights, trade secrets, and other intellectual property. A listing of SCILLC's product/patent coverage may be accessed at [www.onsemi.com/site/pdf/Patent-Marking.pdf](http://www.onsemi.com/site/pdf/Patent-Marking.pdf). SCILLC reserves the right to make changes without further notice to any products herein. SCILLC makes no warranty, representation or guarantee regarding the suitability of its products for any particular purpose, nor does SCILLC assume any liability arising out of the application or use of any product or circuit, and specifically disclaims any and all liability, including without limitation special, consequential or incidental damages. "Typical" parameters which may be provided in SCILLC data sheets and/or specifications can and do vary in different applications and actual performance may vary over time. All operating parameters, including "Typicals" must be validated for each customer application by customer's technical experts. SCILLC does not convey any license under its patent rights nor the rights of others. SCILLC products are not designed, intended, or authorized for use as components in systems intended for surgical implant into the body, or other applications intended to support or sustain life, or for any other application in which the failure of the SCILLC product could create a situation where personal injury or death may occur. Should Buyer purchase or use SCILLC products for any such unintended or unauthorized application, Buyer shall indemnify and hold SCILLC and its officers, employees, subsidiaries, affiliates, and distributors harmless against all claims, costs, damages, and expenses, and reasonable attorney fees arising out of, directly or indirectly, any claim of personal injury or death associated with such unintended or unauthorized use, even if such claim alleges that SCILLC was negligent regarding the design or manufacture of the part. SCILLC is an Equal Opportunity/Affirmative Action Employer. This literature is subject to all applicable copyright laws and is not for resale in any manner.