



Chipsmall Limited consists of a professional team with an average of over 10 year of expertise in the distribution of electronic components. Based in Hongkong, we have already established firm and mutual-benefit business relationships with customers from,Europe,America and south Asia,supplying obsolete and hard-to-find components to meet their specific needs.

With the principle of “Quality Parts,Customers Priority,Honest Operation,and Considerate Service”,our business mainly focus on the distribution of electronic components. Line cards we deal with include Microchip,ALPS,ROHM,Xilinx,Pulse,ON,Everlight and Freescale. Main products comprise IC,Modules,Potentiometer,IC Socket,Relay,Connector.Our parts cover such applications as commercial,industrial, and automotives areas.

We are looking forward to setting up business relationship with you and hope to provide you with the best service and solution. Let us make a better world for our industry!



Contact us

Tel: +86-755-8981 8866 Fax: +86-755-8427 6832

Email & Skype: info@chipsmall.com Web: www.chipsmall.com

Address: A1208, Overseas Decoration Building, #122 Zhenhua RD., Futian, Shenzhen, China





STL8NH3LL

N-channel 30 V, 0.012 Ω , 8 A - PowerFLAT™ (3.3x3.3)
ultra low gate charge STripFET™ Power MOSFET

Features

Type	V _{DSS}	R _{DS(on)}	I _D
STL8NH3LL	30V	<0.015 Ω	8A ⁽¹⁾

- Improved die-to-footprint ratio
- Very low profile package (1mm max)
- Very low thermal resistance
- Very low gate charge
- Low threshold device
- In compliance with the 2002/95/EC European directive

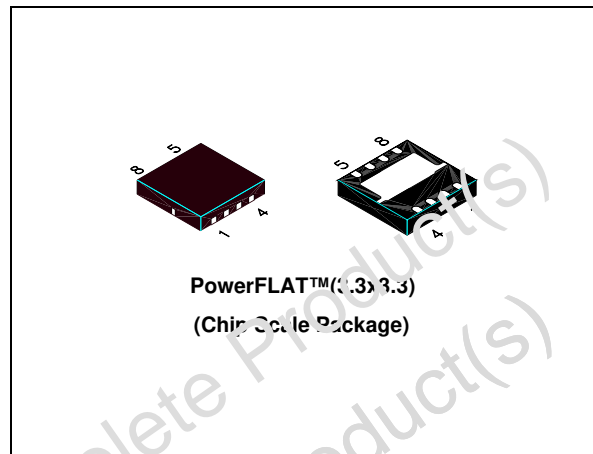

Description

This application specific Power MOSFET is the latest generation of STMicroelectronics unique STripFET™ technology. The resulting transistor is optimized for low on-resistance and minimal gate charge. The chip-scaled PowerFLAT™ package allows a significant board space saving, still boosting the performance.

Applications

- Switching application

Figure 1. Internal schematic diagram

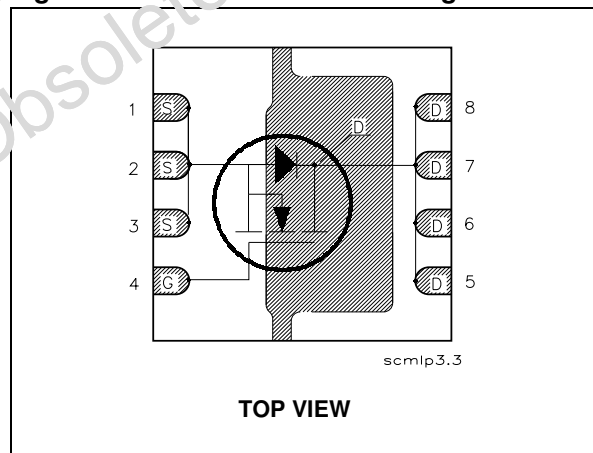

Table 1. Device summary

Order code	Marking	Package	Packaging
STL8NH3LL	8NH3L	PowerFLAT™ (3.3x3.3)	Tape and reel

Contents

1	Electrical ratings	3
2	Electrical characteristics	4
2.1	Electrical characteristics (curves)	6
3	Test circuits	8
4	Package mechanical data	9
5	Revision history	11

Obsolete Product(s) - Obsolete Product(s)
Obsolete Product(s) - Obsolete Product(s)

1 Electrical ratings

Table 2. Absolute maximum ratings

Symbol	Parameter	Value	Unit
V_{DS}	Drain-source voltage ($V_{GS} = 0$)	30	V
V_{GS}	Gate-source voltage	± 18	V
$I_D^{(1)}$	Drain current (continuous) at $T_C = 25^\circ\text{C}$	8	A
$I_D^{(1)}$	Drain current (continuous) at $T_C = 100^\circ\text{C}$	5	A
$I_{DM}^{(2)}$	Drain current (pulsed)	32	A
$P_{TOT}^{(3)}$	Total dissipation at $T_C = 25^\circ\text{C}$	50	W
$P_{TOT}^{(1)}$	Total dissipation at $T_C = 25^\circ\text{C}$?	W
	Derating factor	0.4	W/ $^\circ\text{C}$
T_J	Operating junction temperature	-55 to 150	$^\circ\text{C}$
T_{stg}	Storage temperature		

1. The value is rated according $R_{thj-pcb}$
2. Pulse width limited by safe operating area.
3. The value is rated according R_{thj-c}

Table 3. Thermal resistance

Symbol	Parameter	Value	Unit
$R_{thj-case}$	Thermal resistance junction-case (drain)	2.5	$^\circ\text{C}/\text{W}$
$R_{thj-pcb}^{(1)}$	Thermal resistance junction-pcb	42.8	$^\circ\text{C}/\text{W}$
$R_{thj-pcb}^{(2)}$	Thermal resistance junction-pcb	63.5	$^\circ\text{C}/\text{W}$

1. When mounted on FR-4 board of 1inch², 2oz Cu, $t < 10$ sec
2. Steady state

2 Electrical characteristics

(T_{CASE} = 25 °C unless otherwise specified)

Table 4. On/off states

Symbol	Parameter	Test conditions	Min.	Typ.	Max.	Unit
V _{(BR)DSS}	Drain-Source breakdown voltage	I _D = 250 μA, V _{GS} = 0	30			V
I _{DSS}	Zero gate voltage drain current (V _{GS} = 0)	V _{DS} = max rating, V _{DS} = max rating @ 125°C			1 10	μA μA
I _{GSS}	Gate body leakage current (V _{DS} = 0)	V _{GS} = ±18 V			±100	nA
V _{GS(th)}	Gate threshold voltage	V _{DS} = V _{GS} , I _D = 250 μA	1		2.5	V
R _{DS(on)}	Static drain-source on resistance	V _{GS} = 10 V, I _D = 4 A V _{GS} = 4.5 V, I _D = 4 A		0.012 0.0135	0.015 0.017	Ω Ω

Table 5. Dynamic

Symbol	Parameter	Test conditions	Min.	Typ.	Max.	Unit
g _{fs} ⁽¹⁾	Forward transconductance	V _{DS} = 15 V, I _D = 4 A		30		S
C _{iss}	Input capacitance	V _{DS} = 25 V, f = 1 MHz, V _{GS} = 0		965		pF
C _{oss}	Output capacitance			285		pF
C _{rss}	Reverse transfer capacitance			38		pF
Q _g	Total gate charge	V _{DD} = 15 V, I _D = 8 A		9	12	nC
Q _{gs}	Gate-source charge	V _{GS} = 4.5 V		3.7		nC
Q _{gd}	Gate-drain charge	(see Figure 8)		3		nC
R _G	Gate input resistance	f = 1 MHz gate DC bias = 0 test signal level = 20mV open drain	0.5	1.5	2.5	Ω

1. Pulsed: pulse duration = 300 μs, duty cycle 1.5%

Table 6. Switching times

Symbol	Parameter	Test conditions	Min.	Typ.	Max.	Unit	
t _{d(on)}	Turn-on delay time	V _{DD} = 15 V, I _D = 4 A, R _G = 4.7 Ω, V _{GS} = 4.5 V (see Figure 14)		15		ns	
t _r	Rise time			32		ns	
t _{d(off)}	Turn-off delay time		-		18	-	ns
t _f	Fall Time				8.5		ns

Table 7. Source drain diode

Symbol	Parameter	Test conditions	Min	Typ.	Max	Unit
I_{SD}	Source-drain current		-		8	A
$I_{SDM}^{(1)}$	Source-drain current (pulsed)		-		32	A
$V_{SD}^{(2)}$	Forward on voltage	$I_{SD}=8\text{ A}$, $V_{GS}=0$	-		1.3	V
t_{rr} Q_{rr} I_{RRM}	Reverse recovery time Reverse recovery charge Reverse recovery current	$I_{SD}=8\text{ A}$, $di/dt = 100\text{ A}/\mu\text{s}$, $V_{DD}=20\text{ V}$, $T_j=150\text{ }^\circ\text{C}$ (see Figure 16)	-	24 17.4 1.45		ns nC A

1. Pulse width limited by safe operating area
2. Pulsed: pulse duration= 300 μs , duty cycle 1.5 %

2.1 Electrical characteristics (curves)

Figure 2. Safe operating area

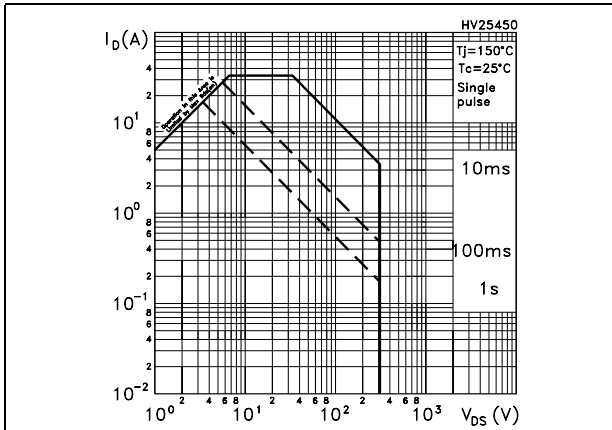

Figure 3. Thermal impedance

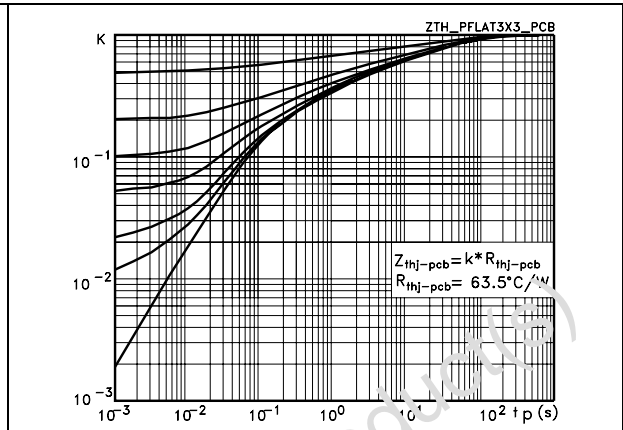

Figure 4. Output characteristics

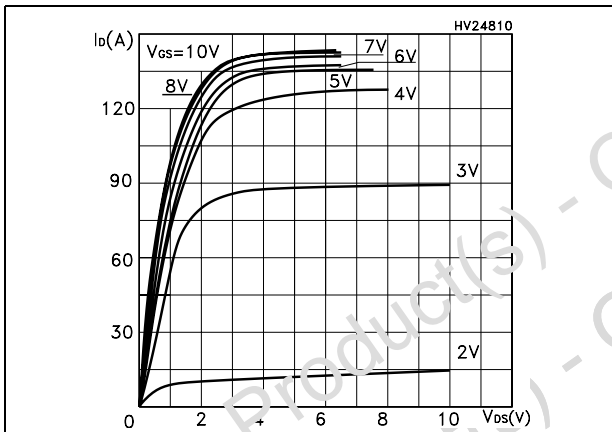

Figure 5. Transfer characteristics

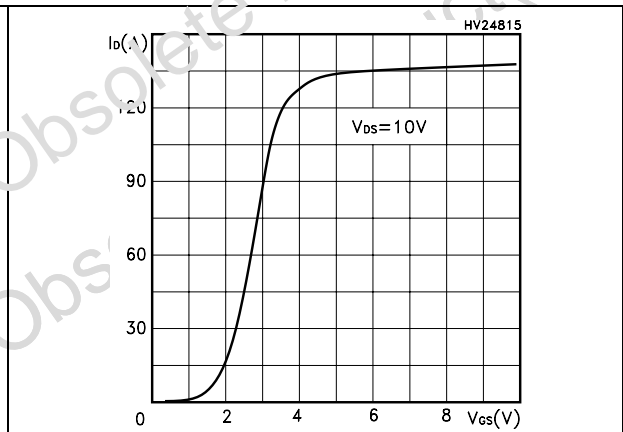

Figure 6. Transconductance

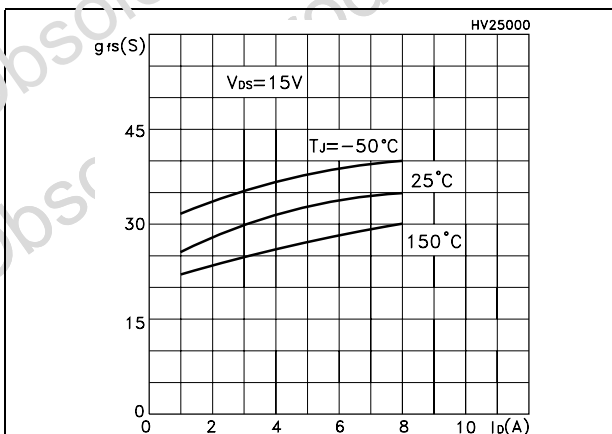

Figure 7. Static drain-source on resistance

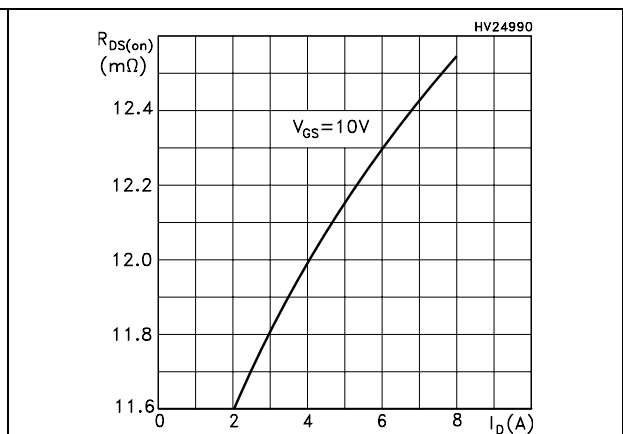

Figure 8. Gate charge vs gate-source voltage Figure 9. Capacitance variations

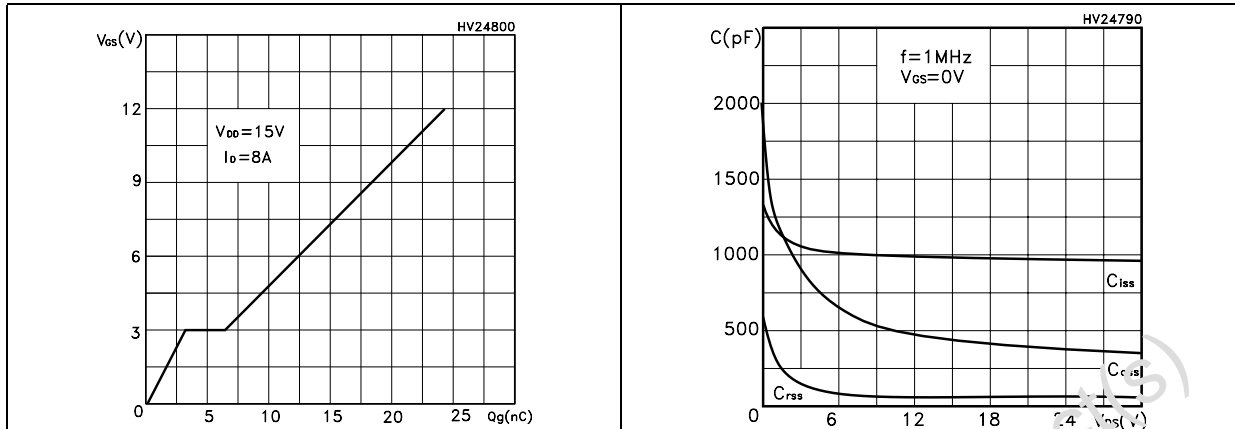

Figure 10. Normalized gate threshold voltage vs temperature Figure 11. Normalized on resistance vs temperature

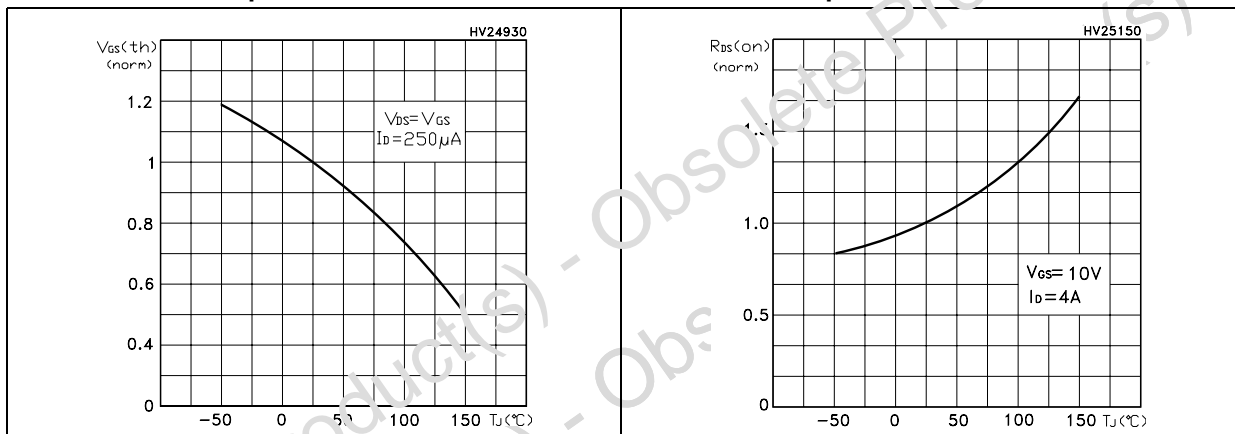
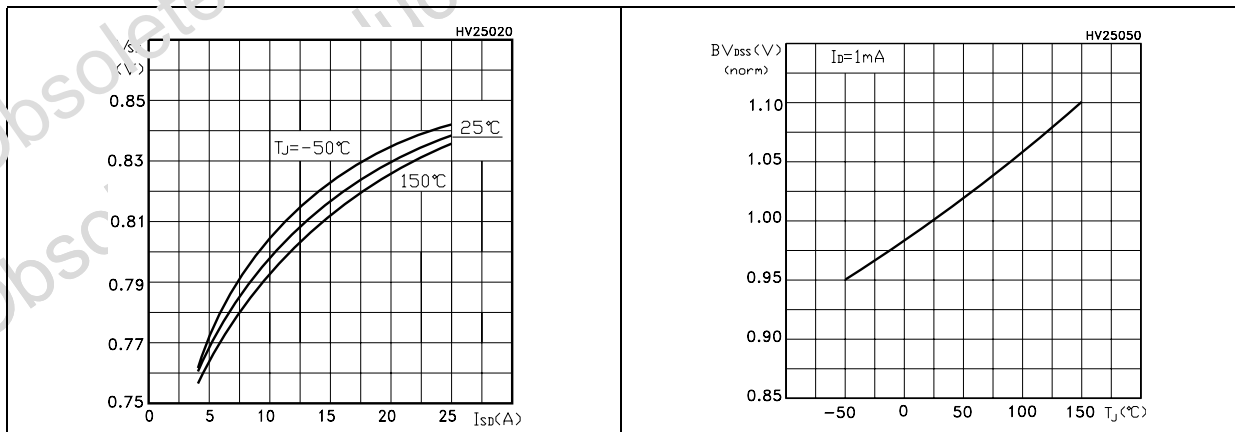

Figure 12. Source-drain diode forward characteristics Figure 13. Normalized B_{VDSS} vs temperature



3 Test circuits

Figure 14. Switching times test circuit for resistive load

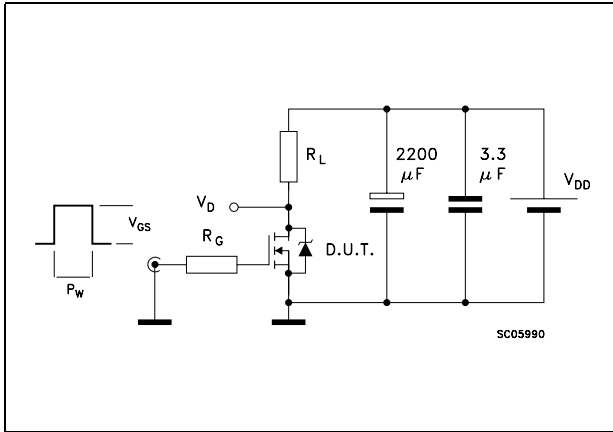

Figure 15. Gate charge test circuit

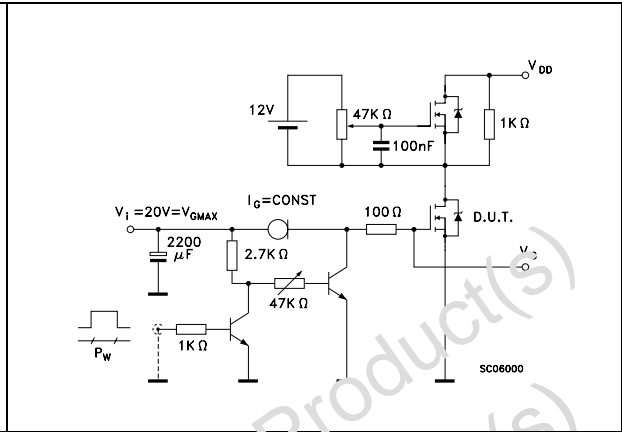

Figure 16. Inductive load switching and diode recovery times

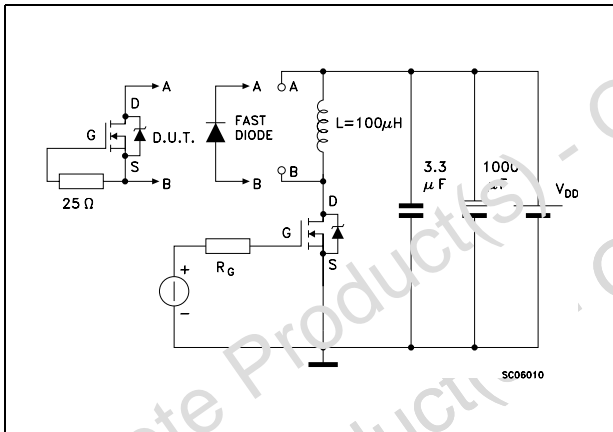

Figure 17. Uncamped inductive load test circuit

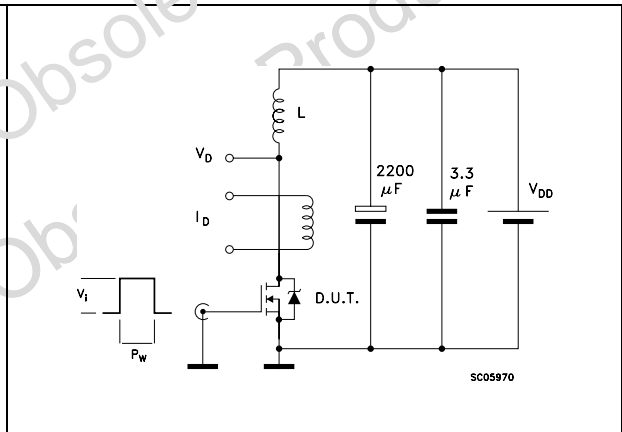

Figure 18. Unclamped inductive waveform

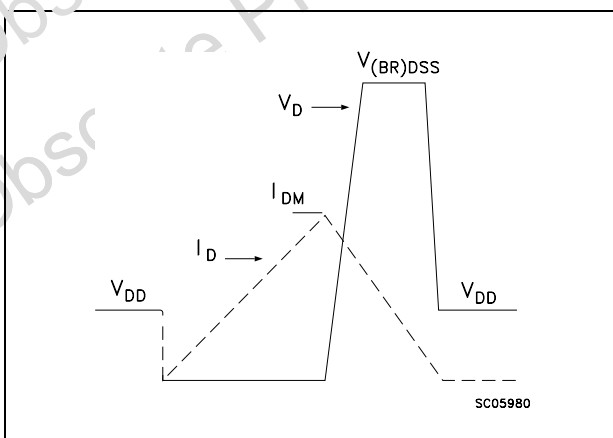
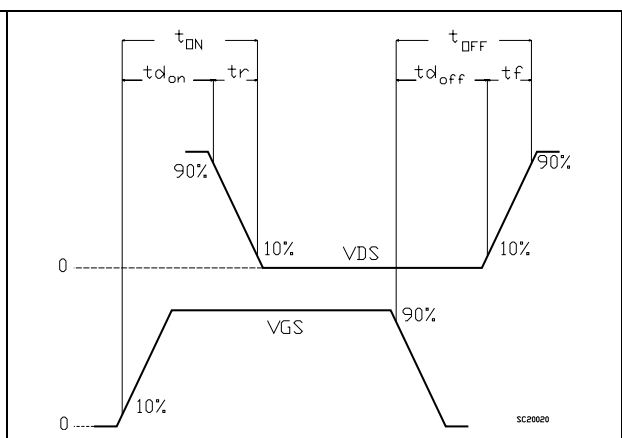

Figure 19. Switching time waveform



4 Package mechanical data

In order to meet environmental requirements, ST offers these devices in different grades of ECOPACK® packages, depending on their level of environmental compliance. ECOPACK® specifications, grade definitions and product status are available at: www.st.com. ECOPACK is an ST trademark.

Table 8. Package dimensions

Dim.	mm.			inch		
	Min.	Typ	Max.	Min.	Typ.	Max.
A	0.80	0.90	1.00	0.031	0.035	0.039
A1		0.02	0.05		0.0007	0.0019
A3		0.20			0.007	
b	0.23	0.30	0.38	0.009	0.011	0.015
C		0.328			0.012	
C1		0.12			0.004	
D		3.30			0.13	
D2	2.50	2.65	2.75	0.098	0.104	0.108
E		3.30			0.13	
E2	1.25	1.40	1.50	0.049	0.055	0.059
F		1.325			0.052	
F1		0.975			0.038	
e		0.65			0.025	
L	0.30		0.50	0.011		0.019

Figure 20. Package drawing

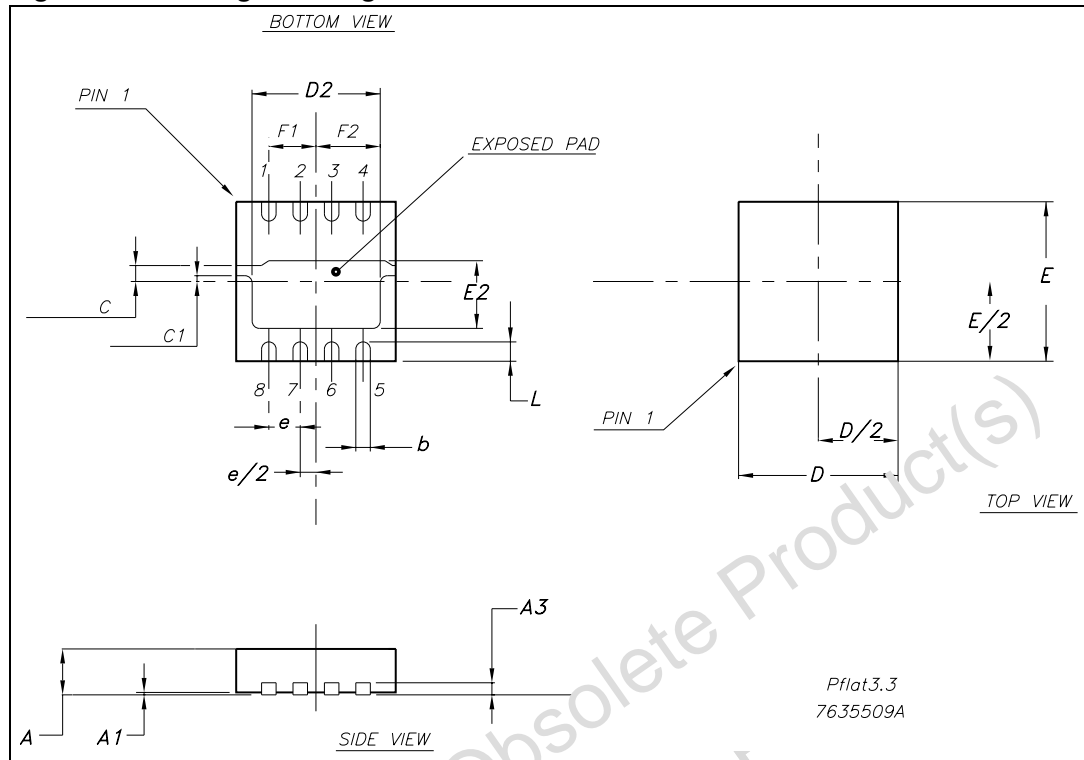
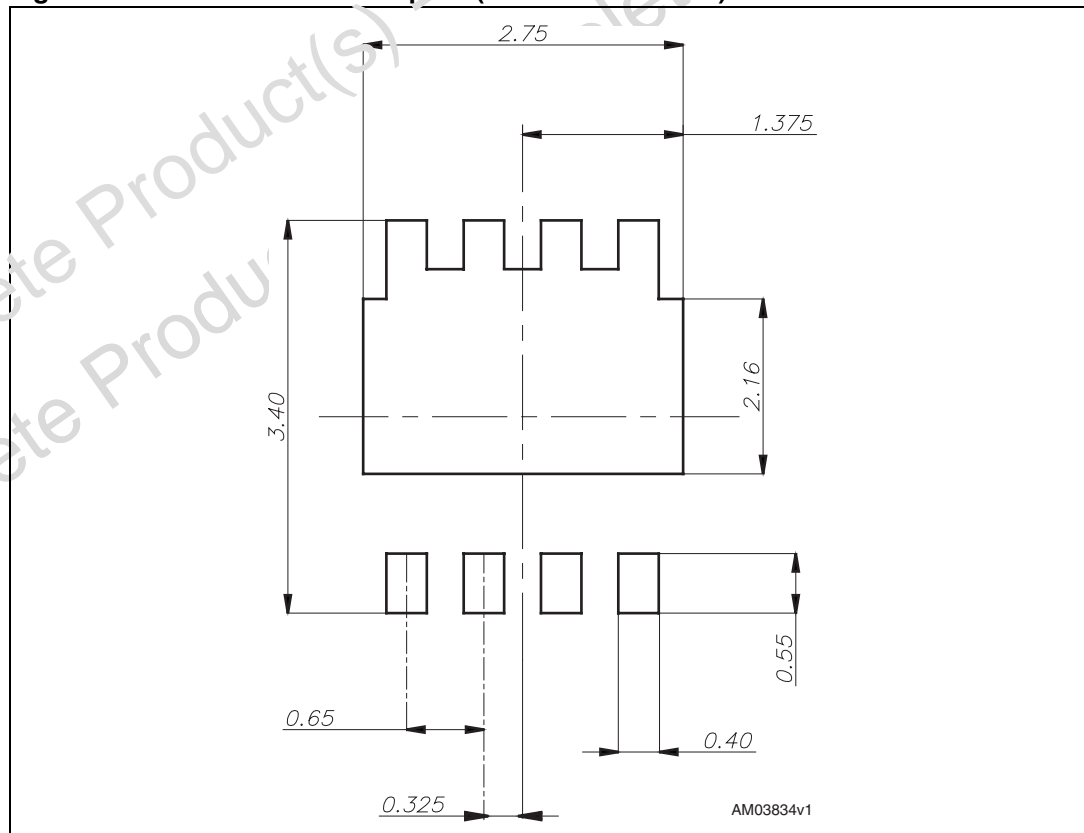

Figure 21. Recommended footprint (dimensions in mm)



5 Revision history

Table 9. Document revision history

Date	Revision	Changes
21-Jul-2004	1	First release
05-Oct-2004	2	Values changed
19-Oct-2004	3	New value inserted
22-Nov-2004	4	Document updated
21-Feb-2005	5	Final version
18-Apr-2005	6	Modified Figure 4 , Figure 6. , Figure 9. , Figure 10.
14-Mar-2006	7	New template
10-Sep-2009	8	Inserted Figure 21

Please Read Carefully:

Information in this document is provided solely in connection with ST products. STMicroelectronics NV and its subsidiaries ("ST") reserve the right to make changes, corrections, modifications or improvements, to this document, and the products and services described herein at any time, without notice.

All ST products are sold pursuant to ST's terms and conditions of sale.

Purchasers are solely responsible for the choice, selection and use of the ST products and services described herein, and ST assumes no liability whatsoever relating to the choice, selection or use of the ST products and services described herein.

No license, express or implied, by estoppel or otherwise, to any intellectual property rights is granted under this document. If any part of this document refers to any third party products or services it shall not be deemed a license grant by ST for the use of such third party products or services, or any intellectual property contained therein or considered as a warranty covering the use in any manner whatsoever of such third party products or services or any intellectual property contained therein.

UNLESS OTHERWISE SET FORTH IN ST'S TERMS AND CONDITIONS OF SALE ST DISCLAIMS ANY EXPRESS OR IMPLIED WARRANTY WITH RESPECT TO THE USE AND/OR SALE OF ST PRODUCTS INCLUDING WITHOUT LIMITATION IMPLIED WARRANTIES OF MERCHANTABILITY, FITNESS FOR A PARTICULAR PURPOSE (AND THEIR EQUIVALENTS UNDER THE LAWS OF ANY JURISDICTION), OR INFRINGEMENT OF ANY PATENT, COPYRIGHT OR OTHER INTELLECTUAL PROPERTY RIGHT.

UNLESS EXPRESSLY APPROVED IN WRITING BY AN AUTHORIZED ST REPRESENTATIVE, ST PRODUCTS ARE NOT RECOMMENDED, AUTHORIZED OR WARRANTED FOR USE IN MILITARY, AIR CRAFT, SPACE, LIFE SAVING, OR LIFE SUSTAINING APPLICATIONS, NOR IN PRODUCTION OR SYSTEMS WHERE FAILURE OR MALFUNCTION MAY RESULT IN PERSONAL INJURY, DEATH, OR SEVERE PROPERTY OR ENVIRONMENTAL DAMAGE. ST PRODUCTS WHICH ARE NOT SPECIFIED AS "AUTOMOTIVE GRADE" MAY ONLY BE USED IN AUTOMOTIVE APPLICATIONS AT USER'S OWN RISK.

Resale of ST products with provisions different from the statements and/or technical features set forth in this document shall immediately void any warranty granted by ST for the ST product or service described herein and shall not create or extend in any manner whatsoever, any liability of ST.

ST and the ST logo are trademarks or registered trademarks of ST in various countries.

Information in this document supersedes and replaces all information previously supplied.

The ST logo is a registered trademark of STMicroelectronics. All other names are the property of their respective owners.

© 2009 STMicroelectronics - All rights reserved

STMicroelectronics group of companies

Australia - Belgium - Brazil - Canada - China - Czech Republic - Finland - France - Germany - Hong Kong - India - Israel - Italy - Japan - Malaysia - Malta - Morocco - Philippines - Singapore - Spain - Sweden - Switzerland - United Kingdom - United States of America

www.st.com