



Chipsmall Limited consists of a professional team with an average of over 10 year of expertise in the distribution of electronic components. Based in Hongkong, we have already established firm and mutual-benefit business relationships with customers from,Europe,America and south Asia,supplying obsolete and hard-to-find components to meet their specific needs.

With the principle of “Quality Parts,Customers Priority,Honest Operation,and Considerate Service”,our business mainly focus on the distribution of electronic components. Line cards we deal with include Microchip,ALPS,ROHM,Xilinx,Pulse,ON,Everlight and Freescale. Main products comprise IC,Modules,Potentiometer,IC Socket,Relay,Connector.Our parts cover such applications as commercial,industrial, and automotives areas.

We are looking forward to setting up business relationship with you and hope to provide you with the best service and solution. Let us make a better world for our industry!



Contact us

Tel: +86-755-8981 8866 Fax: +86-755-8427 6832

Email & Skype: info@chipsmall.com Web: www.chipsmall.com

Address: A1208, Overseas Decoration Building, #122 Zhenhua RD., Futian, Shenzhen, China



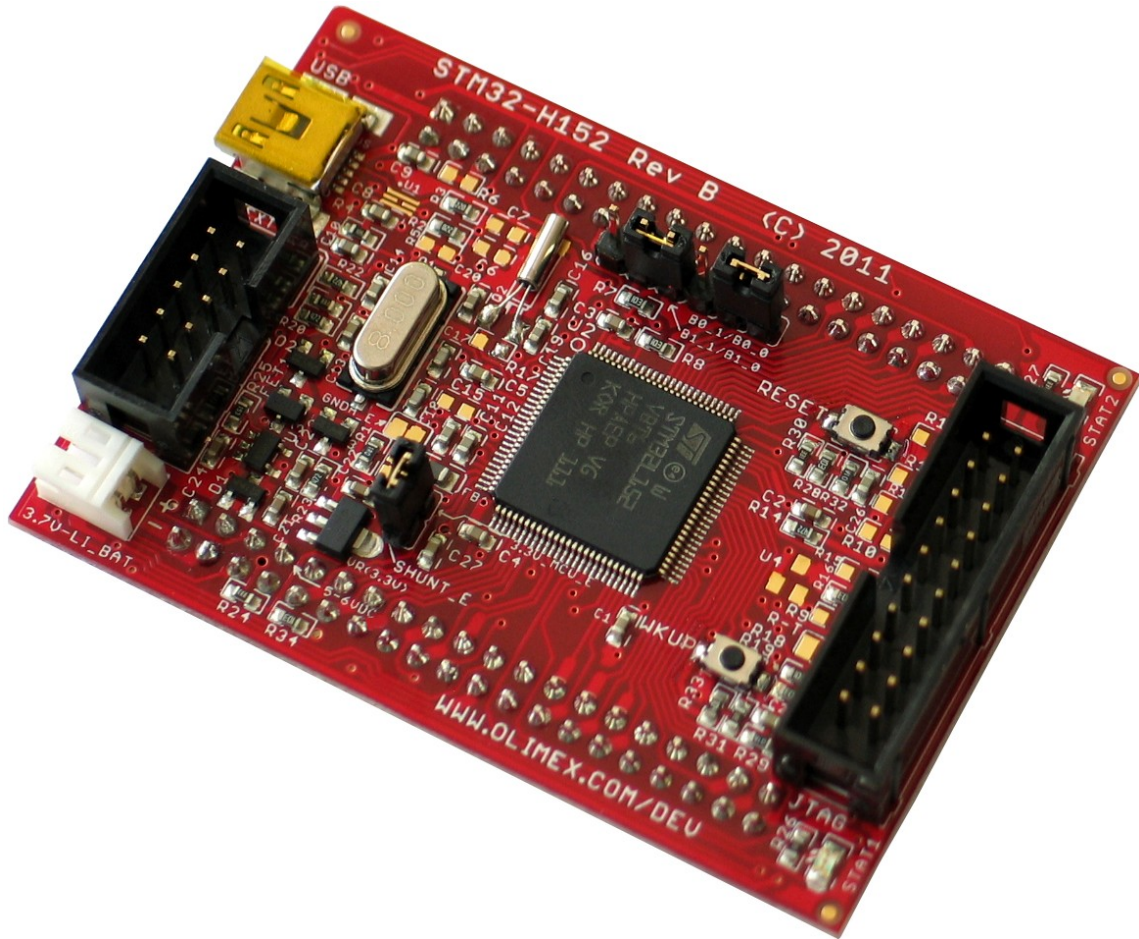

STM32-H152 development board

Users Manual



All boards produced by Olimex are ROHS compliant

Revision Initial, September 2011
Copyright(c) 2011, OLIMEX Ltd, All rights reserved

INTRODUCTION:

STM32-H152 is header board with STM32L152VBT6 ARM Cortex M3 microcontroller from STMicroelectronics. This microcontroller supports various communication interfaces such as USB, three USARTs, two SPIs, two I²C. There are available mini USB, JTAG and UEXT connectors, two buttons – WKUP and RESET, two status leds and extension connectors for most of the microcontroller's pins. All this allows you to build a different projects to be used in a wide range of applications.

BOARD FEATURES:

- MCU: **STM32L152VBT6** – 128 KB Flash, 16 KB Data RAM
- Mini USB
- 3.7V-LI_BAT connector
- Battery charger
- JTAG connector
- UEXT connector
- Two status leds
- Reset circuit
- RESET button
- WKUP button
- Extension connectors for most of the microcontroller pins
- FR-4, 1.5 mm, soldermask, component print
- Dimensions: 70.00 x 50.00 mm (2.76 x 1.97")

ELECTROSTATIC WARNING:

The **STM32-H152** board is shipped in protective anti-static packaging. The board must not be subject to high electrostatic potentials. General practice for working with static sensitive devices should be applied when working with this board.

BOARD USE REQUIREMENTS:

Cables: The cable you will need depends on the programmer/debugger you use. If you use ARM-JTAG-EW, ARM-USB-TINY or ARM-USB-TINY-H, you will need USB A-B cable, if you use ARM-USB-OCD or ARM-USB-OCD-H, you will need USB A-B cable and RS232 cable.

Hardware: Programmer/Debugger [ARM-USB-OCD](#), [ARM-USB-OCD-H](#), [ARM-USB-TINY](#), [ARM-USB-TINY-H](#), [ARM-JTAG-EW](#) or other compatible programming/debugging tool if you work with EW-ARM.

PROCESSOR FEATURES:

STM32-H152 board use ARM 32-bit Cortex™-M3 microcontroller **STM32L152VBT6** from STMicroelectronics with these features:

- Operating conditions
 - Operating power supply range: 1.65 V to 3.6 V (without BOR) or 1.8 V to 3.6 V (with BOR option)
 - Temperature range: -40 to 85 °C
- Low power features
 - 4 modes: Sleep, Low-power run (9 µA at 32 kHz), Low-power sleep (4.4 µA), Stop with RTC (1.45 µA), Stop (570 nA), Standby (300 nA)
 - Dynamic core voltage scaling down to 233 µA/MHz
 - Ultralow leakage per I/O: 50 nA
 - Fast wakeup from Stop: 8 µs
 - Three wakeup pins
- Core: ARM 32-bit Cortex™-M3 CPU
 - 32 MHz maximum frequency, 33.3 DMIPS peak (Dhrystone 2.1)
 - Memory protection unit
- Reset and supply management
 - Low power, ultrasafe BOR (brownout reset) with 5 selectable thresholds
 - Ultralow power POR/PDR
 - Programmable voltage detector (PVD)
- Clock management

- 1 to 24 MHz crystal oscillator
- 32 kHz oscillator for RTC with calibration
- Internal 16 MHz factory-trimmed RC
- Internal 37 kHz low consumption RC
- Internal multispeed low power RC, 64 kHz to 4 MHz with a consumption down to 1.5 μ A
- PLL for CPU clock and USB (48 MHz)
- Low power calendar RTC
 - Alarm, periodic wakeup from Stop/Standby
- Memories
 - 128 Kbyte of Flash memory with ECC
 - 4 Kbyte of data EEPROM with ECC
 - 16 Kbyte of RAM
- 83 fast I/Os (73 of which are 5 V-tolerant) all mappable on 16 external interrupt vectors
- Development support
 - Serial wire debug, JTAG and trace
- DMA: 7-channel DMA controller, supporting timers, ADC, SPIs, I2Cs and USARTs
- LCD 8 \times 40 or 4 \times 44 with step-up converter
- 12-bit ADC up to 1 Msps/24 channels
 - Temperature sensor and internal voltage reference
 - Operates down to 1.8 V
- 2 \times 12-bit DACs with output buffers
- 2 ultralow power comparators
 - Window mode and wakeup capability
- 10 timers:
 - 6 \times 16-bit general-purpose timers, each with up to 4 IC/OC/PWM channels
 - 2 \times 16-bit basic timers
 - 2 \times watchdog timers (independent and window)
- 8 communication interfaces:
 - 2 \times I2C interfaces (SMBus/PMBus)
 - 3 \times USARTs (ISO 7816 interface, LIN, IrDA capability, modem control)
 - 2 \times SPIs (16 Mbit/s)
 - USB 2.0 full speed interface
- CRC calculation unit, 96-bit unique ID

Peripheral		STM32L152VBT6
Flash - Kbytes		128
RAM - Kbytes		16
Timers	General-purpose	6
	Basic	2
Communication interfaces	SPI	2
	I ² C	2
	USART	3
	USB	1
GPIOs		83
12-bit synchronized ADC Number of channels		1 24 channels
12-bit DAC Number of channels		2 2
CPU frequency		32 MHz
Operating voltage		1.8 V to 3.6 V (down to 1.65 V at power-down) with BOR option 1.65 V to 3.6 V without BOR option
Operating temperatures		Ambient temperatures: -40 to +85 °C Junction temperature: -40 to + 105 °C

BLOCK DIAGRAM:

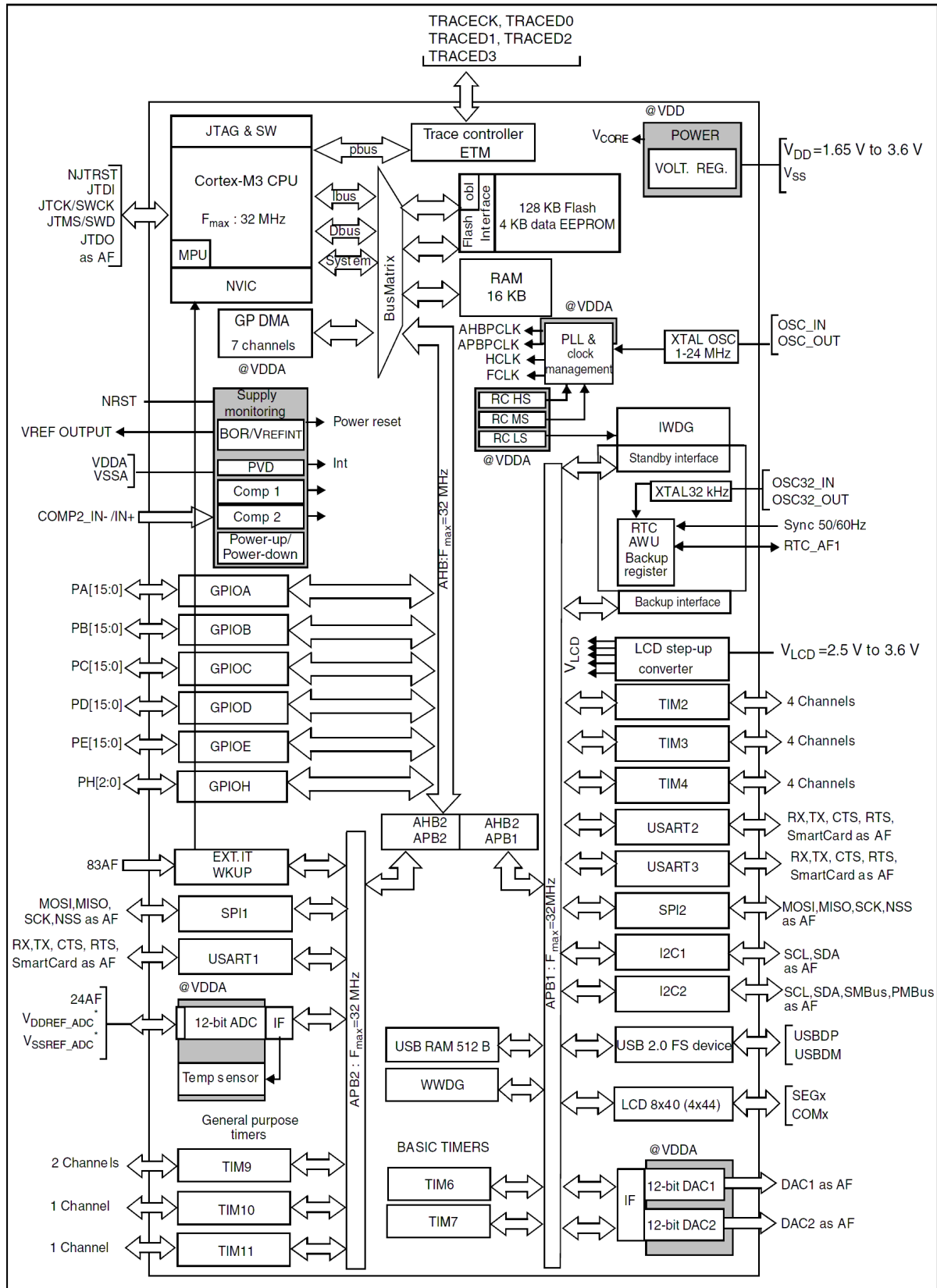

AF = Alternate Function function on I/O port pin.

MEMORY MAP:

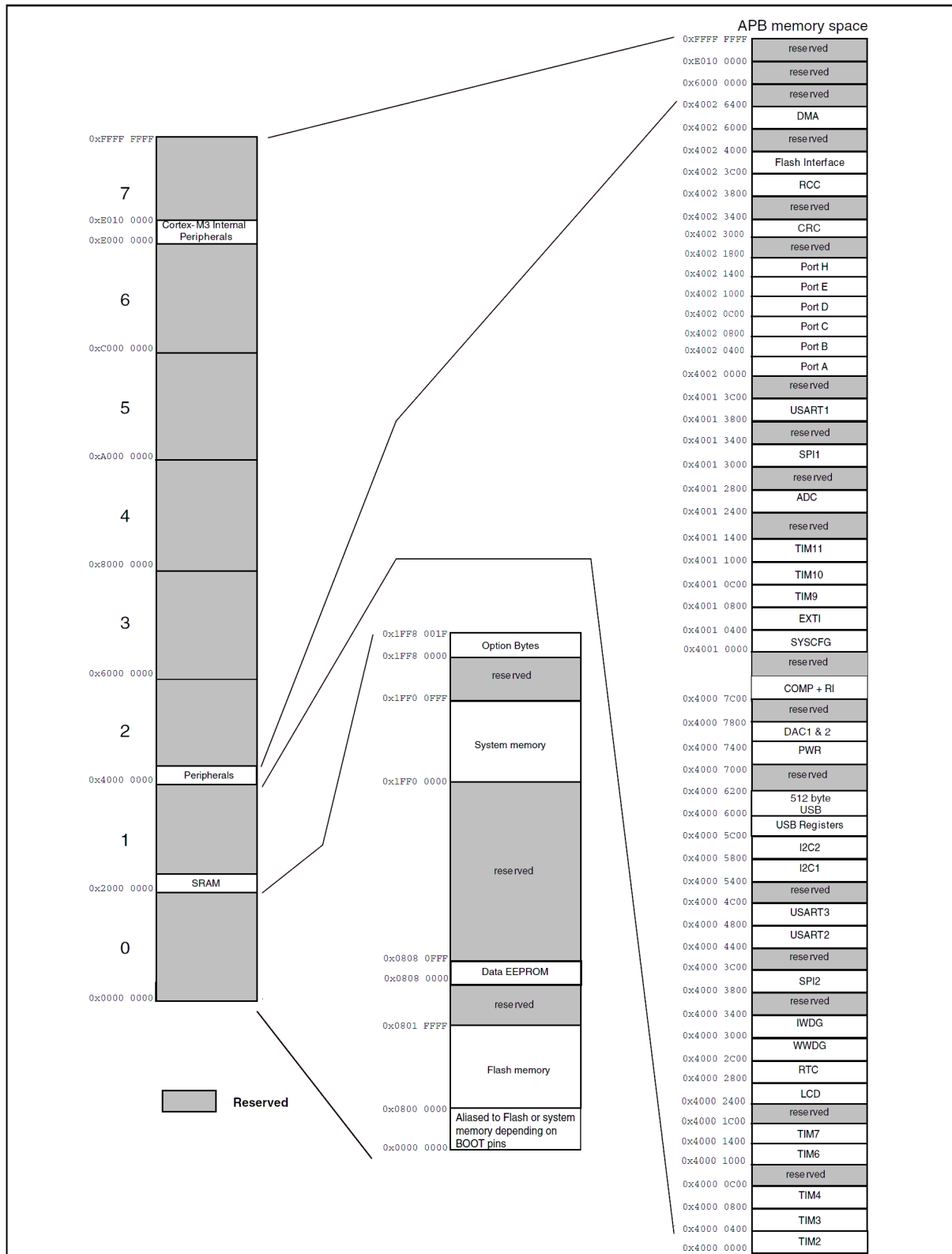

STM32-H152

Rev. B
COPYRIGHT(C) 2011, OLIMEX LTD.
http://www.olimex.com/dev

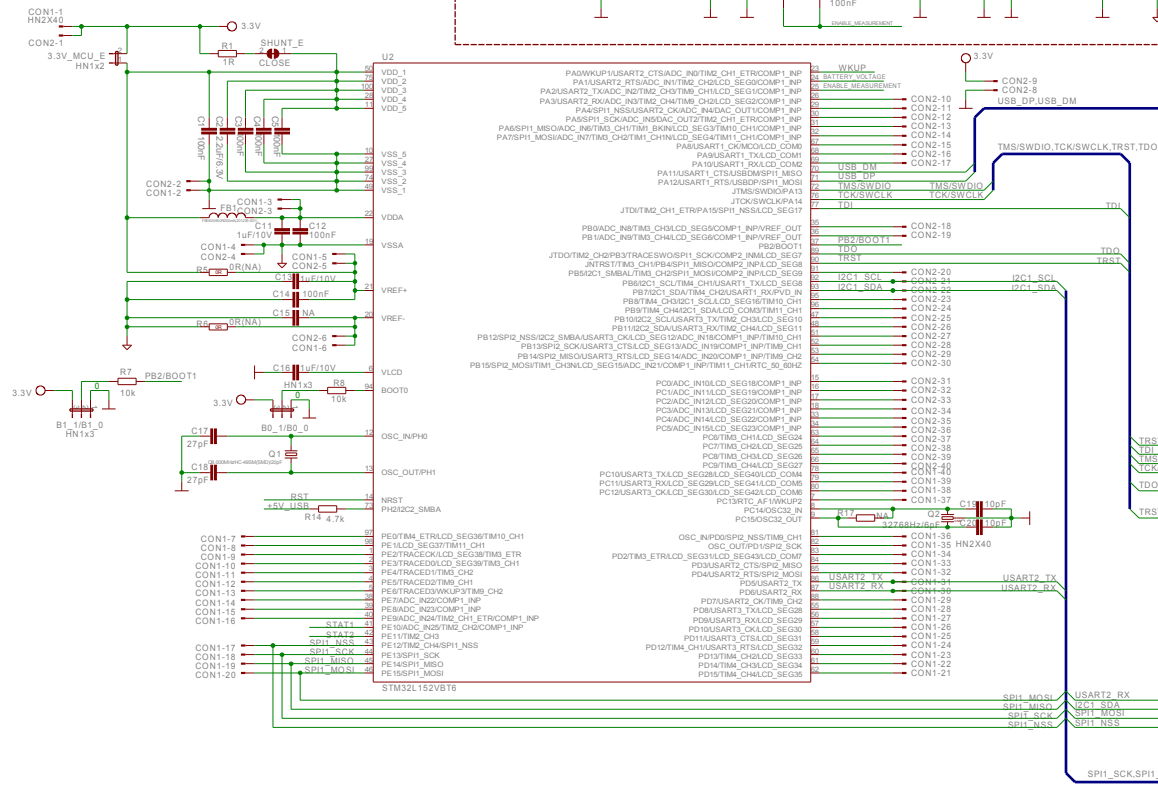
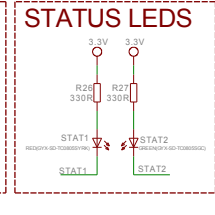
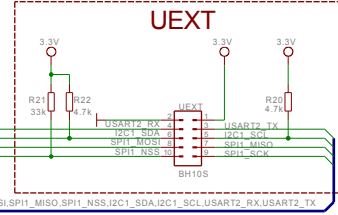
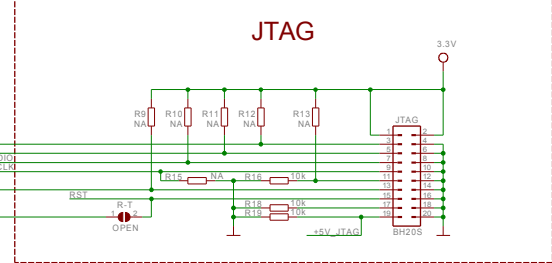
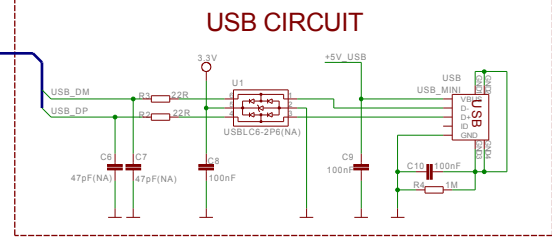
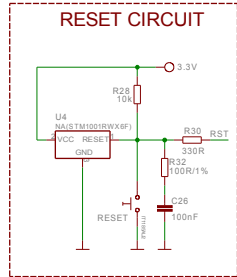
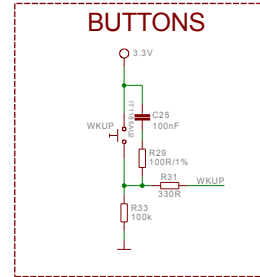
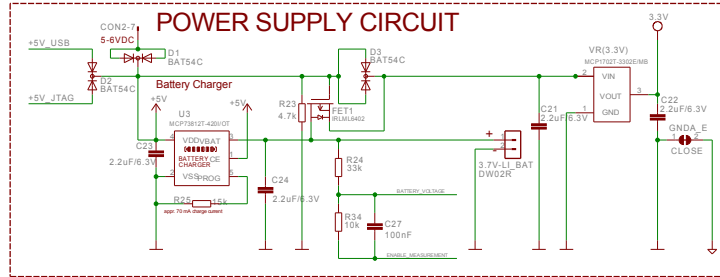

BOARD LAYOUT:

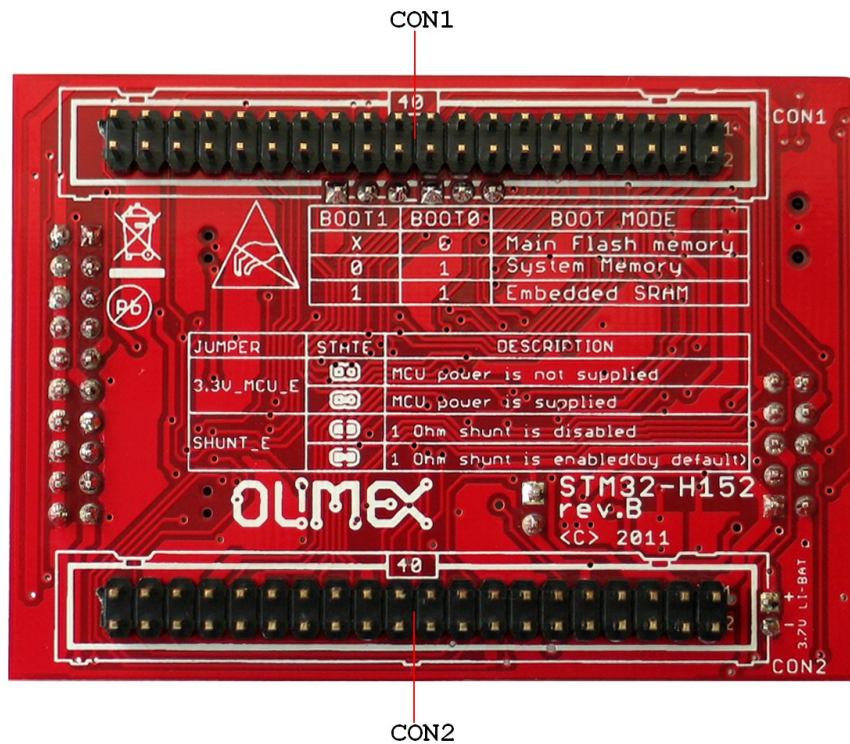
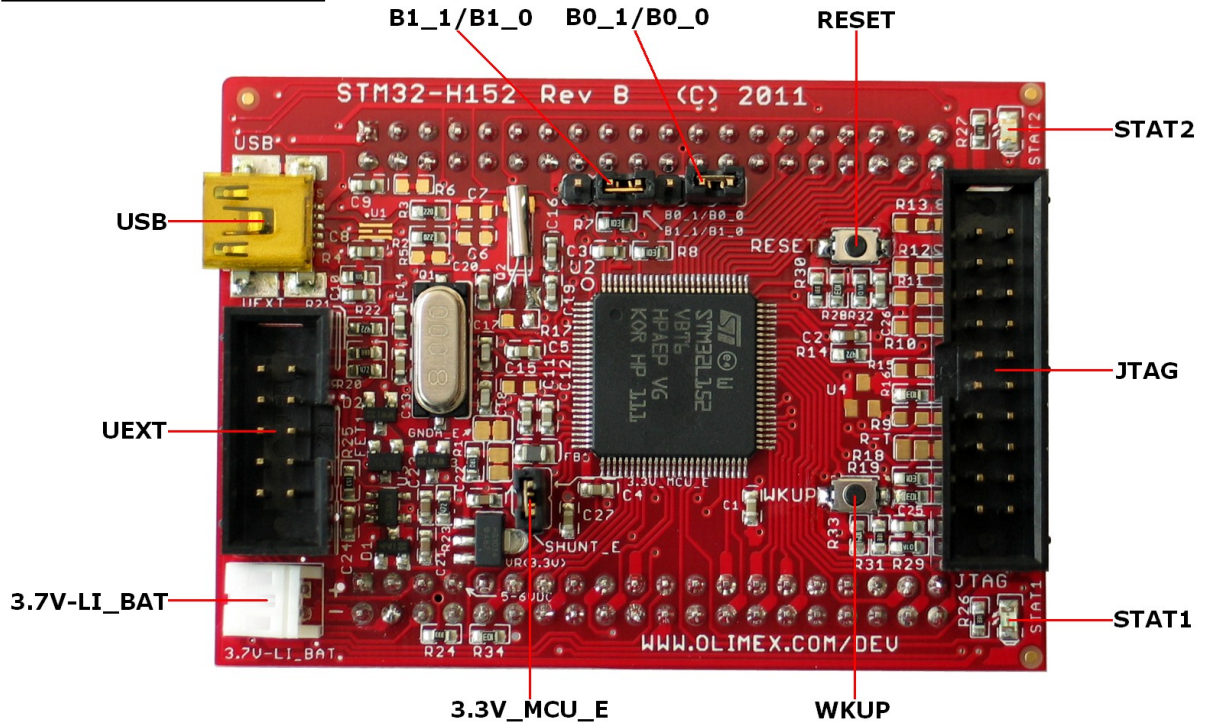

POWER SUPPLY CIRCUIT:

STM32-H152 can take power from:

-USB - +5V_USB.

-J-link - +5V_JTAG.

-Battery connector - +3.7V lithium battery.

-Extension connector CON2 pin 7 (VIN) - (5÷6) VDC.

The programmed board power consumption is about 30 mA.

Note that if the battery is connected to 3,7V-Li BAT connector and some of other power sources(USB, JTAG, CON2 pin 7 (VIN)) are present and the battery is discharged then the battery will be charged until the charge complete.

RESET CIRCUIT:

STM32-H152 reset circuit includes R28 (10k), R30 (330Ω), R32 (100Ω/1%), C26 (100nF), STM32L152VBT6 pin 14 (NRST) and RESET button.

CLOCK CIRCUIT:

Quartz crystal (Q1) 8 MHz is connected to STM32L152VBT6 pin 12 (OSC_IN/PH0) and pin 13 (OSC_OUT/PH1).

Quartz crystal (Q2) 32.768 kHz is connected to STM32L152VBT6 pin 8 (PC14/OSC32_IN) and pin 9 (PC15/OSC32_OUT).

JUMPER DESCRIPTION:

R-T



When this jumper is closed, RST and TRST are connected. When this jumper is opened, RST and TRST are separated.
Default state is opened.

SHUNT_E



When this jumper is closed, 1 Ohm shunt is enabled. When this jumper is opened, 1 Ohm shunt is disabled.
Default state is closed.

GND_A_E



When this jumper is closed, the board analog ground is enabled. When this jumper is opened, the board analog ground is disabled.
Default state is closed.

3.3V_MCU_E



When this jumper is closed, STM32L152VBT6 power supply is enabled. When this jumper is opened, STM32L152VBT6 power supply is disabled.
Default state is closed.

B0_1/B0_0



This jumper, when is in position B0_1 – connects STM32L152VBT6 pin 94 (BOOT0) via R8 (10k) to 3.3V, when the jumper is in position B0_0 – connects STM32L152VBT6 pin 94 (BOOT0) via R8 (10k) to GND.

Default state is closed in position B0_0.

B1_1/B1_0



This jumper, when is in position B1_1 – connects STM32L152VBT6 pin 37 (PB2/BOOT1) via R7 (10k) to 3.3V, when the jumper is in position B1_0 – connects STM32L152VBT6 pin 37 (PB2/BOOT1) via R7 (10k) to GND.

Default state is closed in position B1_0.

The boot mode is selected depending on jumpers B0_1/B0_0 and B1_1/B1_0 configuration:

- When B0_1/B0_0 is closed in position B0_0 and B1_1/B1_0 position doesn't matter the boot mode is Main Flash Memory.
- When B0_1/B0_0 is closed in position B0_1 and B1_1/B1_0 is closed in position B1_0 – the boot mode is System Memory.
- When B0_1/B0_0 is closed in position B0_1 and B1_1/B1_0 is closed in position B1_1 – the boot mode is Embedded SRAM.

INPUT/OUTPUT:

Status led (red), with name **STAT1** is connected to STM32L152VBT6 pin 41 (PF10).

Status led (green), with name **STAT2** is connected to STM32L152VBT6 pin 42 (PF11).

User button with name **WKUP** is connected to STM32L152VBT6 pin 23 (PA0/WKUP1).

User button with name **RESET** is connected to STM32L152VBT6 pin 14 (NRST).

EXTERNAL CONNECTORS DESCRIPTION:

UEXT:

Pin #	Signal Name
1	VCC (3.3V)
2	GND
3	USART2_TX
4	USART2_RX
5	I2C1_SCL
6	I2C1_SDA
7	SPI1_MISO
8	SPI1_MOSI
9	SPI1_SCK
10	SPI1_NSS

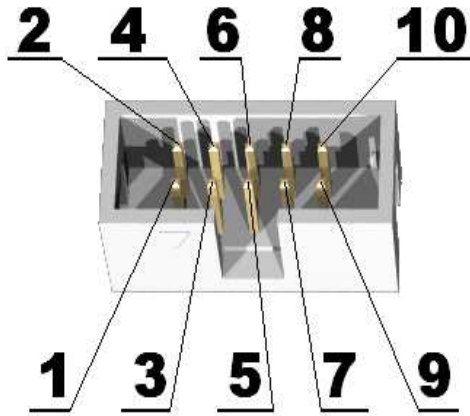

USB:

Pin #	Signal Name
1	+5V_USB
2	USB_DM
3	USB_DP
4	Not Connected
5	GND

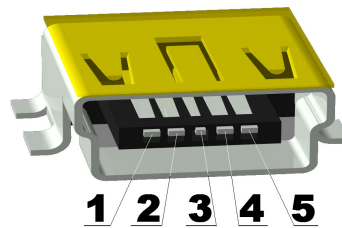

3.7V-LI BAT:

Pin #	Signal Name
1	VBAT
2	GND

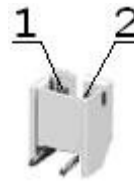

JTAG:

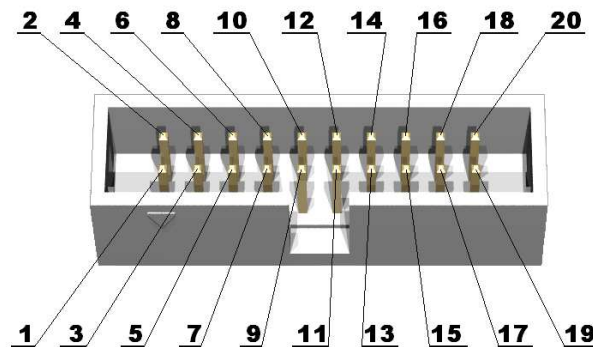

Pin #	Signal Name	Pin #	Signal Name
1	VCC (3.3V)	2	VCC (3.3V)
3	TRST	4	GND
5	TDI	6	GND
7	TMS/SWDIO	8	GND
9	TCK/SWCLK	10	GND
11	Via 10k to GND	12	GND
13	TDO	14	GND
15	RST	16	GND
17	Via 10k to GND	18	GND
19	+5V_JTAG	20	GND

CON1:

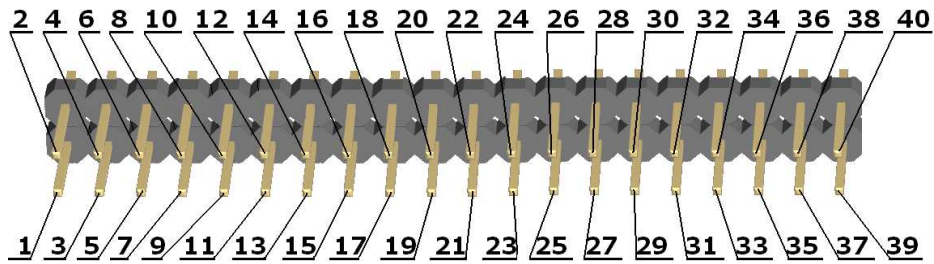

Pin #	Signal Name	Pin #	Signal Name
1	VCC (3.3V)	2	GND
3	VDDA	4	AGND
5	VREF+	6	VREF-
7	PE0	8	PE1
9	PE2	10	PE3
11	PE4	12	PE5
13	PE6	14	PE7
15	PE8	16	PE9
17	SPI1_NSS	18	SPI1_SCK
19	SPI1_MISO	20	SPI1_MOSI
21	PD15	22	PD14
23	PD13	24	PD12
25	PD11	26	PD10
27	PD9	28	PD8
29	PD7	30	USART2_RX
31	USART2_TX	32	PD4
33	PD3	34	PD2
35	PD1	36	PD0
37	PC13	38	PC12
39	PC11	40	PC10

CON2:

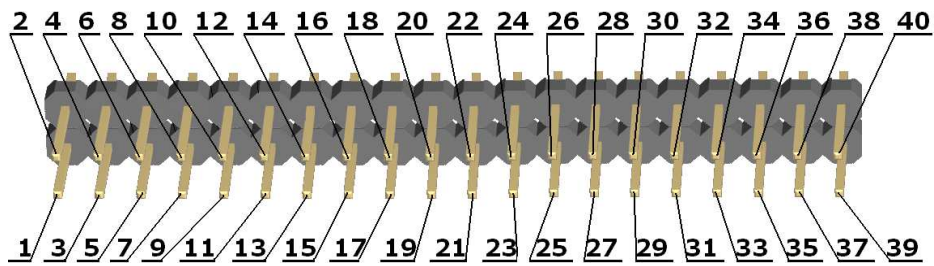

Pin #	Signal Name	Pin #	Signal Name
1	VCC (3.3V)	2	GND
3	VDDA	4	AGND
5	VREF+	6	VREF-
7	VIN	8	GND
9	VCC (3.3V)	10	PA3
11	PA4	12	PA5
13	PA6	14	PA7
15	PA8	16	PA9
17	PA10	18	PB0
19	PB1	20	PB5
21	I2C1_SCL	22	I2C1_SDA
23	PB8	24	PB9
25	PB10	26	PB11
27	PB12	28	PB13
29	PB14	30	PB15
31	PC0	32	PC1
33	PC2	34	PC3
35	PC4	36	PC5
37	PC6	38	PC7
39	PC8	40	PC9

MECHANICAL DIMENSIONS:

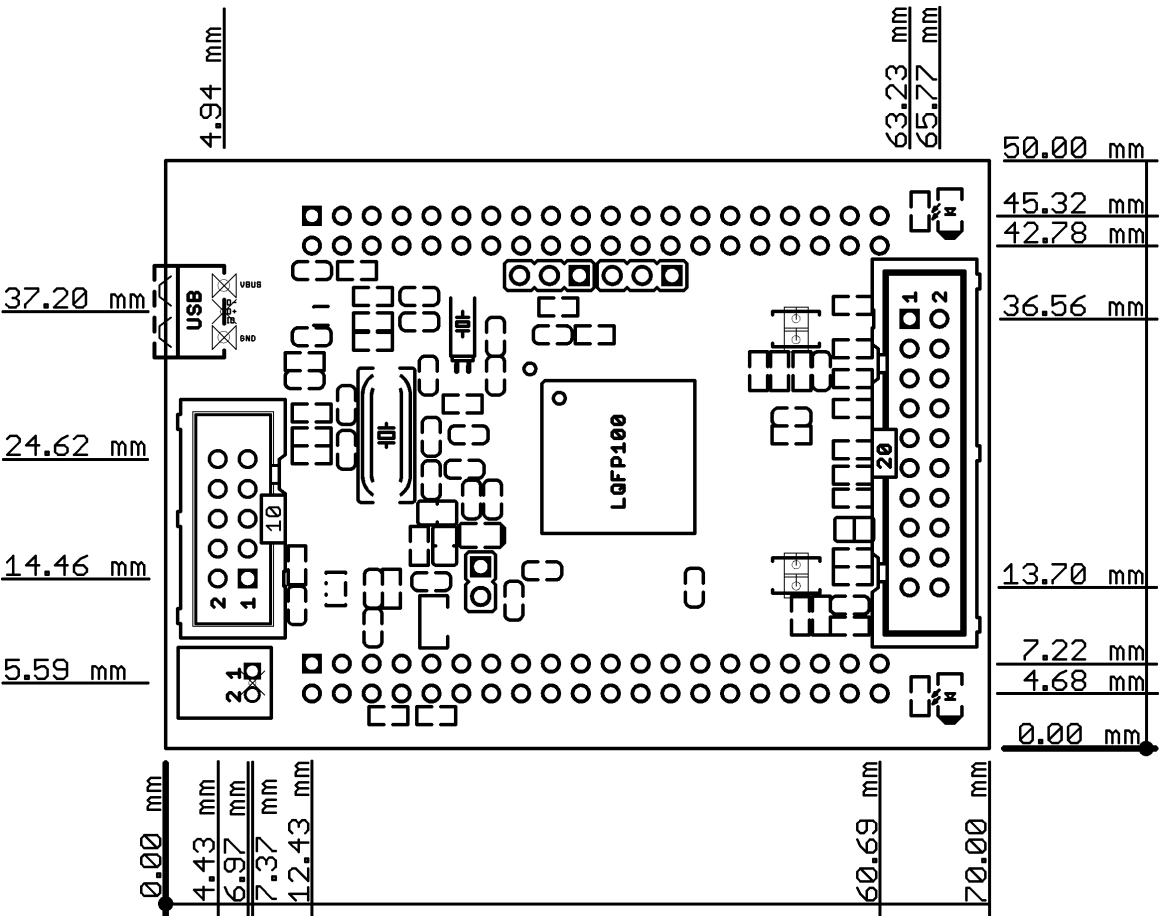

AVAILABLE DEMO SOFTWARE:

- [Demo software USB mouse and Blinking LED](#) for EW-ARM
- [Setup GCC+Eclipse for STM32 on MAC](#)

ORDER CODE:

STM32-H152 - assembled and tested board

How to order?

You can order to us directly or by any of our distributors.
Check our web www.olimex.com/dev for more info.

Revision history:

Boar's revision:	Rev. B, June 2011
Manual's revision:	Rev. Initial, September 2011

Disclaimer:

© 2011 Olimex Ltd. All rights reserved. Olimex®, logo and combinations thereof, are registered trademarks of Olimex Ltd. Other terms and product names may be trademarks of others.

The information in this document is provided in connection with Olimex products. No license, express or implied or otherwise, to any intellectual property right is granted by this document or in connection with the sale of Olimex products.

Neither the whole nor any part of the information contained in or the product described in this document may be adapted or reproduced in any material from except with the prior written permission of the copyright holder.

The product described in this document is subject to continuous development and improvements. All particulars of the product and its use contained in this document are given by OLIMEX in good faith. However all warranties implied or expressed including but not limited to implied warranties of merchantability or fitness for purpose are excluded.

This document is intended only to assist the reader in the use of the product. OLIMEX Ltd. shall not be liable for any loss or damage arising from the use of any information in this document or any error or omission in such information or any incorrect use of the product.