



Chipsmall Limited consists of a professional team with an average of over 10 year of expertise in the distribution of electronic components. Based in Hongkong, we have already established firm and mutual-benefit business relationships with customers from,Europe,America and south Asia,supplying obsolete and hard-to-find components to meet their specific needs.

With the principle of “Quality Parts,Customers Priority,Honest Operation,and Considerate Service”,our business mainly focus on the distribution of electronic components. Line cards we deal with include Microchip,ALPS,ROHM,Xilinx,Pulse,ON,Everlight and Freescale. Main products comprise IC,Modules,Potentiometer,IC Socket,Relay,Connector.Our parts cover such applications as commercial,industrial, and automotives areas.

We are looking forward to setting up business relationship with you and hope to provide you with the best service and solution. Let us make a better world for our industry!



## Contact us

Tel: +86-755-8981 8866 Fax: +86-755-8427 6832

Email & Skype: info@chipsmall.com Web: www.chipsmall.com

Address: A1208, Overseas Decoration Building, #122 Zhenhua RD., Futian, Shenzhen, China



Ultra-low-power 32-bit MCU ARM<sup>®</sup>-based Cortex<sup>®</sup>-M3,  
128KB Flash, 10KB SRAM, 2KB EEPROM, LCD, USB, ADC, DAC

Datasheet –production data

## Features

- Ultra-low-power platform
  - 1.8 V to 3.6 V power supply
  - -40°C to 85°C temperature range
  - 0.3 µA Standby mode (2 wakeup pins)
  - 0.9 µA Standby mode + RTC
  - 0.57 µA Stop mode (16 wakeup lines)
  - 1.2 µA Stop mode + RTC
  - 9 µA Low-power run mode
  - 214 µA/MHz Run mode
  - 10 nA ultra-low I/O leakage
  - < 8 µs wakeup time
- Core: 32-bit ARM<sup>®</sup> Cortex<sup>®</sup>-M3 CPU
  - From 32 kHz up to 32 MHz max
  - 1.25 DMIPS/MHz (Dhrystone 2.1)
  - Memory protection unit
- Reset and supply management
  - Ultra-safe, low-power BOR (brownout reset) with 5 selectable thresholds
  - Ultra-low-power POR/PDR
  - Programmable voltage detector (PVD)
- Clock sources
  - 1 to 24 MHz crystal oscillator
  - 32 kHz oscillator for RTC with calibration
  - High-speed internal 16 MHz
  - Internal low-power 37 kHz RC
  - Internal multispeed low-power 65 kHz to 4.2 MHz
  - PLL for CPU clock and USB (48 MHz)
- Pre-programmed bootloader
  - USART supported
- Development support
  - Serial wire debug supported
  - JTAG supported
- Up to 51 fast I/Os (42 I/Os 5V tolerant), all mappable on 16 external interrupt vectors

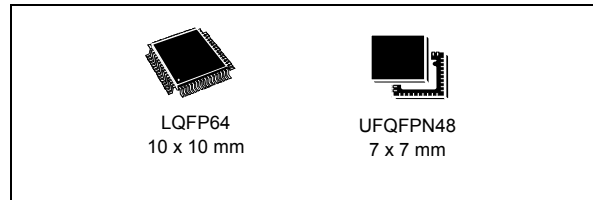

- Memories
  - Up to 128 Kbytes Flash memory with ECC
  - Up to 10 Kbytes RAM
  - Up to 2 Kbytes of true EEPROM with ECC
  - 20-byte backup register
- LCD Driver for up to 8x28 segments
- Analog peripherals
  - 12-bit ADC 1 Msps up to 20 channels
  - 12-bit DAC 2 channels with output buffers
  - Two ultra-low-power comparators
- Seven DMA controller channels
- Eight communication interface peripherals
  - One USB 2.0
  - Three USARTs (ISO 7816, IrDA)
  - Two SPIs (16 Mbit/s)
  - Two I2Cs (SMBus/PMBus)
- Ten timers:
  - Six 16-bit timers with up to 4 IC/OC/PWM channels
  - Two 16-bit basic timers
  - Two watchdog timers (independent and window)
- CRC calculation unit
- All packages ECOPACK<sup>®</sup>2

# Contents

<b>1</b>	<b>Introduction</b>	<b>8</b>
<b>2</b>	<b>Description</b>	<b>9</b>
2.1	Device overview	10
2.2	Ultra-low-power device continuum	11
2.2.1	Performance	11
2.2.2	Shared peripherals	11
2.2.3	Common system strategy	11
2.2.4	Features	11
<b>3</b>	<b>Functional overview</b>	<b>12</b>
3.1	Low-power modes	13
3.2	ARM <sup>®</sup> Cortex <sup>®</sup> -M3 core with MPU	17
3.3	Reset and supply management	18
3.3.1	Power supply schemes	18
3.3.2	Power supply supervisor	18
3.3.3	Voltage regulator	19
3.3.4	Boot modes	19
3.4	Clock management	20
3.5	Low-power real-time clock and backup registers	22
3.6	GPIOs (general-purpose inputs/outputs)	22
3.7	Memories	23
3.8	DMA (direct memory access)	23
3.9	LCD (liquid crystal display)	23
3.10	ADC (analog-to-digital converter)	24
3.10.1	Internal voltage reference ( $V_{REFINT}$ )	24
3.11	DAC (digital-to-analog converter)	24
3.12	Ultra-low-power comparators and reference voltage	25
3.13	Routing interface	25
3.14	Timers and watchdogs	25
3.14.1	General-purpose timers (TIM2, TIM3, TIM4, TIM9, TIM10 and TIM11)	26
3.14.2	Basic timers (TIM6 and TIM7)	26
3.14.3	SysTick timer	26

3.14.4	Independent watchdog (IWDG)	26
3.14.5	Window watchdog (WWDG)	27
3.15	Communication interfaces	27
3.15.1	I <sup>2</sup> C bus	27
3.15.2	Universal synchronous/asynchronous receiver transmitter (USART)	27
3.15.3	Serial peripheral interface (SPI)	27
3.15.4	Universal serial bus (USB)	27
3.16	CRC (cyclic redundancy check) calculation unit	28
3.17	Development support	28
<b>4</b>	<b>Pin descriptions</b>	<b>29</b>
<b>5</b>	<b>Memory mapping</b>	<b>39</b>
<b>6</b>	<b>Electrical characteristics</b>	<b>40</b>
6.1	Parameter conditions	40
6.1.1	Minimum and maximum values	40
6.1.2	Typical values	40
6.1.3	Typical curves	40
6.1.4	Loading capacitor	40
6.1.5	Pin input voltage	40
6.1.6	Power supply scheme	41
6.1.7	Optional LCD power supply scheme	42
6.1.8	Current consumption measurement	42
6.2	Absolute maximum ratings	43
6.3	Operating conditions	44
6.3.1	General operating conditions	44
6.3.2	Embedded reset and power control block characteristics	45
6.3.3	Embedded internal reference voltage	47
6.3.4	Supply current characteristics	48
6.3.5	Wakeup time from Low-power mode	57
6.3.6	External clock source characteristics	59
6.3.7	Internal clock source characteristics	64
6.3.8	PLL characteristics	66
6.3.9	Memory characteristics	67
6.3.10	EMC characteristics	68
6.3.11	Electrical sensitivity characteristics	69

---

6.3.12	I/O current injection characteristics	70
6.3.13	I/O port characteristics	71
6.3.14	NRST pin characteristics	74
6.3.15	TIM timer characteristics	75
6.3.16	Communication interfaces	76
6.3.17	12-bit ADC characteristics	82
6.3.18	DAC electrical specifications	86
6.3.19	Comparator	88
6.3.20	LCD controller	90
<b>7</b>	<b>Package information</b>	<b>91</b>
7.1	LQFP64 10 x 10 mm, 64-pin low-profile quad flat package information	91
7.2	UFQFPN48 7 x 7 mm, 0.5 mm pitch, package information	94
7.3	Thermal characteristics	97
7.3.1	Reference document	98
<b>8</b>	<b>Ordering information</b>	<b>99</b>
<b>9</b>	<b>Revision history</b>	<b>100</b>

## List of tables

Table 1.	Ultra-low-power STM32L100C6 and STM32L100R8/RB device features and peripheral counts	10
Table 2.	Functionalities depending on the operating power supply range	14
Table 3.	CPU frequency range depending on dynamic voltage scaling	15
Table 4.	Working mode-dependent functionalities (from Run/active down to standby)	16
Table 5.	Timer feature comparison	25
Table 6.	Legend/abbreviations used in the pinout table	31
Table 7.	STM32L100C6 and STM32L100R8/RB pin definitions	32
Table 8.	Alternate function input/output	36
Table 9.	Voltage characteristics	43
Table 10.	Current characteristics	43
Table 11.	Thermal characteristics	44
Table 12.	General operating conditions	44
Table 13.	Embedded reset and power control block characteristics	45
Table 14.	Embedded internal reference voltage calibration values	47
Table 15.	Embedded internal reference voltage	47
Table 16.	Current consumption in Run mode, code with data processing running from Flash	49
Table 17.	Current consumption in Run mode, code with data processing running from RAM	50
Table 18.	Current consumption in Sleep mode	51
Table 19.	Current consumption in Low power run mode	52
Table 20.	Current consumption in Low power sleep mode	53
Table 21.	Typical and maximum current consumptions in Stop mode	54
Table 22.	Typical and maximum current consumptions in Standby mode	55
Table 23.	Peripheral current consumption	56
Table 24.	Low-power mode wakeup timings	58
Table 25.	High-speed external user clock characteristics	59
Table 26.	Low-speed external user clock characteristics	60
Table 27.	HSE oscillator characteristics	60
Table 28.	LSE oscillator characteristics ( $f_{LSE} = 32.768$ kHz)	62
Table 29.	HSI oscillator characteristics	64
Table 30.	LSI oscillator characteristics	64
Table 31.	MSI oscillator characteristics	65
Table 32.	PLL characteristics	66
Table 33.	RAM and hardware registers	67
Table 34.	Flash memory and data EEPROM characteristics	67
Table 35.	Flash memory, data EEPROM endurance and data retention	67
Table 36.	EMS characteristics	68
Table 37.	EMI characteristics	69
Table 38.	ESD absolute maximum ratings	69
Table 39.	Electrical sensitivities	70
Table 40.	I/O current injection susceptibility	70
Table 41.	I/O static characteristics	71
Table 42.	Output voltage characteristics	72
Table 43.	I/O AC characteristics	73
Table 44.	NRST pin characteristics	74
Table 45.	TIMx characteristics	75
Table 46.	I <sup>2</sup> C characteristics	76
Table 47.	SCL frequency ( $f_{PCLK1} = 32$ MHz, $V_{DD} = V_{DD\_I2C} = 3.3$ V)	77

---

Table 48.	SPI characteristics	78
Table 49.	USB startup time	80
Table 50.	USB DC electrical characteristics	81
Table 51.	USB: full speed electrical characteristics	81
Table 52.	ADC clock frequency	82
Table 53.	ADC characteristics	82
Table 54.	ADC accuracy	83
Table 55.	Maximum source impedance $R_{AIN\ max}$	85
Table 56.	DAC characteristics	86
Table 57.	Comparator 1 characteristics	88
Table 58.	Comparator 2 characteristics	89
Table 59.	LCD controller characteristics	90
Table 60.	LQFP64 10 x 10 mm, 64-pin low-profile quad flat package mechanical data	91
Table 61.	UFQFPN48 7 x 7 mm, 0.5 mm pitch, package mechanical data	95
Table 62.	Thermal characteristics	97
Table 63.	Ordering information scheme	99
Table 64.	Document revision history	100

## List of figures

Figure 1.	Ultra-low-power STM32L100C6 and STM32L100R8/RB block diagram	12
Figure 2.	Clock tree	21
Figure 3.	STM32L100C6 and STM32L100R8/RB LQFP64 pinout	29
Figure 4.	STM32L100C6 and STM32L100R8/RB UFQFPN48 pinout	30
Figure 5.	Memory map	39
Figure 6.	Pin loading conditions	40
Figure 7.	Pin input voltage	40
Figure 8.	Power supply scheme	41
Figure 9.	Optional LCD power supply scheme	42
Figure 10.	Current consumption measurement scheme	42
Figure 11.	High-speed external clock source AC timing diagram	59
Figure 12.	Low-speed external clock source AC timing diagram	60
Figure 13.	HSE oscillator circuit diagram	62
Figure 14.	Typical application with a 32.768 kHz crystal	63
Figure 15.	I/O AC characteristics definition	74
Figure 16.	Recommended NRST pin protection	75
Figure 17.	I <sup>2</sup> C bus AC waveforms and measurement circuit	77
Figure 18.	SPI timing diagram - slave mode and CPHA = 0	79
Figure 19.	SPI timing diagram - slave mode and CPHA = 1 <sup>(1)</sup>	79
Figure 20.	SPI timing diagram - master mode <sup>(1)</sup>	80
Figure 21.	USB timings: definition of data signal rise and fall time	81
Figure 22.	ADC accuracy characteristics	84
Figure 23.	Typical connection diagram using the ADC	84
Figure 24.	Maximum dynamic current consumption on V <sub>DDA</sub> supply pin during ADC conversion	85
Figure 25.	12-bit buffered /non-buffered DAC	88
Figure 26.	LQFP64 10 x 10 mm, 64-pin low-profile quad flat package outline	91
Figure 27.	LQFP64 10 x 10 mm, 64-pin low-profile quad flat package recommended footprint	92
Figure 28.	LQFP64 10 x 10 mm, 64-pin low-profile quad flat package top view example	93
Figure 29.	UFQFPN48 7 x 7 mm, 0.5 mm pitch, package outline	94
Figure 30.	UFQFPN48 7 x 7 mm, 0.5 mm pitch, package recommended footprint	95
Figure 31.	UFQFPN48 7 x 7 mm, 0.5 mm pitch, package top view example	96
Figure 32.	Thermal resistance	97



# 1 Introduction

This datasheet provides the ordering information and mechanical device characteristics of the STM32L100C6 and STM32L100R8/B ultra-low-power ARM<sup>®</sup> Cortex<sup>®</sup>-M3 based microcontrollers product line.

The ultra-low-power STM32L100C6 and STM32L100R8/RB microcontroller family includes devices in 2 different package types: 48 or 64 pins. Depending on the device chosen, different sets of peripherals are included, the description below gives an overview of the complete range of peripherals proposed in this family.

These features make the ultra-low-power STM32L100C6 and STM32L100R8/RB microcontroller family suitable for a wide range of applications:

- Medical and handheld equipment
- Application control and user interface
- PC peripherals, gaming, GPS and sport equipment
- Alarm systems, Wired and wireless sensors, Video intercom
- Utility metering

This STM32L100C6 and STM32L100R8/B datasheet should be read in conjunction with the STM32L1xxxx reference manual (RM0038). The document "Getting started with STM32L1xxxx hardware development" AN3216 gives a hardware implementation overview.

Both documents are available from the STMicroelectronics website [www.st.com](http://www.st.com).

For information on the ARM<sup>®</sup> Cortex<sup>®</sup>-M3 core please refer to the Cortex<sup>®</sup>-M3 Technical Reference Manual, available from the ARM website.

*Figure 1* shows the general block diagram of the device family.

**Caution:** This datasheet does not apply to:

- STM32L100C6-A
- STM32L100R8-A
- STM32L100RB-A

covered by a separate datasheet.

## 2 Description

The ultra-low-power STM32L100C6 and STM32L100R8/RB devices incorporate the connectivity power of the universal serial bus (USB) with the high-performance ARM<sup>®</sup> Cortex<sup>®</sup>-M3 32-bit RISC core operating at a frequency of 32 MHz (33.3 DMIPS), a memory protection unit (MPU), high-speed embedded memories (Flash memory up to 128 Kbytes and RAM up to 10 Kbytes) and an extensive range of enhanced I/Os and peripherals connected to two APB buses.

All the devices offer a 12-bit ADC, 2 DACs and 2 ultra-low-power comparators, six general-purpose 16-bit timers and two basic timers, which can be used as time bases.

Moreover, the STM32L100C6 and STM32L100R8/RB devices contain standard and advanced communication interfaces: up to two I<sup>2</sup>Cs and SPIs, three USARTs and a USB.

They also include a real-time clock with sub-second counting and a set of backup registers that remain powered in Standby mode.

Finally, the integrated LCD controller has a built-in LCD voltage generator that allows to drive up to 8 multiplexed LCDs with contrast independent of the supply voltage.

The ultra-low-power STM32L100C6 and STM32L100R8/RB devices operate from a 1.8 to 3.6 V power supply. They are available in the -40 to +85 °C temperature range. A comprehensive set of power-saving modes allows the design of low-power applications.



## 2.1 Device overview

Table 1. Ultra-low-power STM32L100C6 and STM32L100R8/RB device features and peripheral counts

Peripheral		STM32L100C6	STM32L100R8/B	
Flash (Kbytes)		32	64	128
Data EEPROM (Kbytes)		2		
RAM (Kbytes)		4	8	10
Timers	General-purpose	6		
	Basic	2		
Communication interfaces	SPI	2		
	I <sup>2</sup> C	2		
	USART	3		
	USB	1		
GPIOs		37	51	
12-bit synchronized ADC Number of channels		1 14 channels	1 20 channels	
12-bit DAC Number of channels		2 2		
LCD COM x SEG		4x18	4x32 8x28	
Comparator		2		
Max. CPU frequency		32 MHz		
Operating voltage		1.8 V to 3.6 V		
Operating temperatures		Ambient temperatures: -40 to +85 °C Junction temperature: -40 to +105 °C		
Packages		UFQFPN48	LQFP64	

## 2.2 Ultra-low-power device continuum

The ultra-low-power family offers a large choice of cores and features. From a proprietary 8-bit core up to the Cortex-M3, including the Cortex-M0+, the STM8Lx and STM32Lx series offer the best range of choices to meet your requirements in terms of ultra-low-power features. The STM32 Ultra-low-power series is an ideal fit for applications like gas/water meters, keyboard/mouse, or wearable devices for fitness and healthcare. Numerous built-in features like LCD drivers, dual-bank memory, low-power Run mode, op-amp, AES-128bit, DAC, crystal-less USB and many others, allow to build highly cost-optimized applications by reducing the BOM.

*Note: STMicroelectronics as a reliable and long-term manufacturer ensures as much as possible the pin-to-pin compatibility between any STM8Lx and STM32Lx devices and between any of the STM32Lx and STM32Fx series. Thanks to this unprecedented scalability, your existing applications can be upgraded to respond to the latest market features and efficiency demand.*

### 2.2.1 Performance

All families incorporate highly energy-efficient cores with both Harvard architecture and pipelined execution: advanced STM8 core for STM8L families and ARM Cortex-M3 core for STM32L family. In addition specific care for the design architecture has been taken to optimize the mA/DMIPS and mA/MHz ratios.

This allows the ultra-Low-power performance to range from 5 up to 33.3 DMIPs.

### 2.2.2 Shared peripherals

STM8L15xxx and STM32L1xxxx share identical peripherals which ensure a very easy migration from one family to another:

- Analog peripherals: ADC, DAC and comparators
- Digital peripherals: RTC and some communication interfaces

### 2.2.3 Common system strategy

To offer flexibility and optimize performance, the STM8L15xxx and STM32L1xxxx families use a common architecture:

- Common power supply range from 1.8 V to 3.6 V
- Architecture optimized to reach ultra-low consumption both in low-power modes and Run mode
- Fast startup strategy from low-power modes
- Flexible system clock
- Ultra-safe reset: same reset strategy including power-on reset, power-down reset, brownout reset and programmable voltage detector.

### 2.2.4 Features

ST ultra-low-power continuum also lies in feature compatibility:

- More than 10 packages with pin count from 20 to 144 pins and size down to 3 x 3 mm
- Memory density ranging from 4 to 512 Kbytes

### 3 Functional overview

Figure 1 shows the block diagram.

Figure 1. Ultra-low-power STM32L100C6 and STM32L100R8/RB block diagram

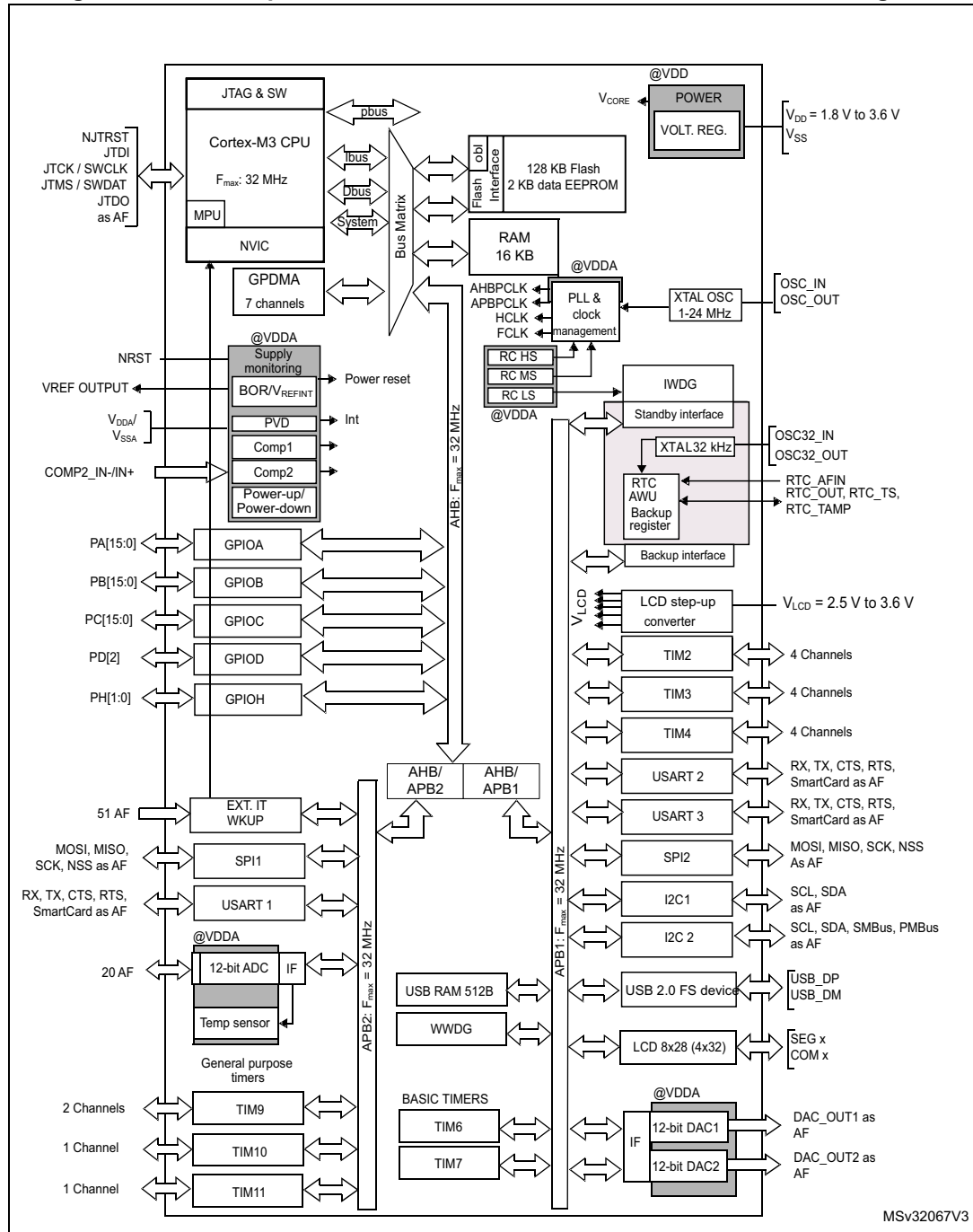

1. AF = alternate function on I/O port pin.

### 3.1 Low-power modes

The ultra-low-power STM32L100C6 and STM32L100R8/RB devices support dynamic voltage scaling to optimize its power consumption in run mode. The voltage from the internal low-drop regulator that supplies the logic can be adjusted according to the system's maximum operating frequency and the external voltage supply:

- In Range 1 ( $V_{DD}$  range limited to 2.0-3.6 V), the CPU runs at up to 32 MHz (refer to [Table 16](#) for consumption).
- In Range 2 (full  $V_{DD}$  range), the CPU runs at up to 16 MHz (refer to [Table 16](#) for consumption)
- In Range 3 (full  $V_{DD}$  range), the CPU runs at up to 4 MHz (generated only with the multispeed internal RC oscillator clock source). Refer to [Table 16](#) for consumption.

Seven low-power modes are provided to achieve the best compromise between low-power consumption, short startup time and available wakeup sources:

- **Sleep mode**  
In Sleep mode, only the CPU is stopped. All peripherals continue to operate and can wake up the CPU when an interrupt/event occurs.  
Sleep mode power consumption: refer to [Table 18](#).
- **Low-power Run mode**  
This mode is achieved with the multispeed internal (MSI) RC oscillator set to the minimum clock (less than 131 kHz), execution from SRAM or Flash memory, and internal regulator in low-power mode to minimize the regulator's operating current. In the low-power Run mode, the clock frequency and the number of enabled peripherals are both limited.  
Low-power Run mode consumption: refer to [Table 19](#).
- **Low-power Sleep mode**  
This mode is achieved by entering the Sleep mode with the internal voltage regulator in low-power mode to minimize the regulator's operating current. In the low-power Sleep mode, both the clock frequency and the number of enabled peripherals are limited; a typical example would be to have a timer running at 32 kHz.  
When wakeup is triggered by an event or an interrupt, the system reverts to the run mode with the regulator on.  
Low-power Sleep mode consumption: refer to [Table 20](#).
- **Stop mode with RTC**  
Stop mode achieves the lowest power consumption while retaining the RAM and register contents and real time clock. All clocks in the  $V_{CORE}$  domain are stopped, the PLL, MSI RC, HSI RC and HSE crystal oscillators are disabled. The LSE or LSI is still running. The voltage regulator is in the low-power mode.  
The device can be woken up from Stop mode by any of the EXTI line, in 8  $\mu$ s. The EXTI line source can be one of the 16 external lines. It can be the PVD output, the Comparator 1 event or Comparator 2 event (if internal reference voltage is on), it can be the RTC alarm(s), the USB wakeup, the RTC tamper events, the RTC timestamp event or the RTC wakeup.
- **Stop mode without RTC**  
Stop mode achieves the lowest power consumption while retaining the RAM and register contents. All clocks are stopped, the PLL, MSI RC, HSI and LSI RC, LSE and HSE crystal oscillators are disabled. The voltage regulator is in the low-power mode.  
The device can be woken up from Stop mode by any of the EXTI line, in 8  $\mu$ s. The EXTI

line source can be one of the 16 external lines. It can be the PVD output, the Comparator 1 event or Comparator 2 event (if internal reference voltage is on). It can also be wakened by the USB wakeup.

Stop mode consumption: refer to [Table 21](#).

- **Standby mode with RTC**

Standby mode is used to achieve the lowest power consumption and real time clock. The internal voltage regulator is switched off so that the entire  $V_{CORE}$  domain is powered off. The PLL, MSI RC, HSI RC and HSE crystal oscillators are also switched off. The LSE or LSI is still running. After entering Standby mode, the RAM and register contents are lost except for registers in the Standby circuitry (wakeup logic, IWDG, RTC, LSI, LSE Crystal 32K osc, RCC\_CSR).

The device exits Standby mode in 60  $\mu$ s when an external reset (NRST pin), an IWDG reset, a rising edge on one of the two WKUP pins, RTC alarm (Alarm A or Alarm B), RTC tamper event, RTC timestamp event or RTC Wakeup event occurs.

- **Standby mode without RTC**

Standby mode is used to achieve the lowest power consumption. The internal voltage regulator is switched off so that the entire  $V_{CORE}$  domain is powered off. The PLL, MSI RC, HSI and LSI RC, HSE and LSE crystal oscillators are also switched off. After entering Standby mode, the RAM and register contents are lost except for registers in the Standby circuitry (wakeup logic, IWDG, RTC, LSI, LSE Crystal 32K osc, RCC\_CSR).

The device exits Standby mode in 60  $\mu$ s when an external reset (NRST pin) or a rising edge on one of the two WKUP pin occurs.

Standby mode consumption: refer to [Table 22](#).

*Note:* The RTC, the IWDG, and the corresponding clock sources are not stopped by entering the Stop or Standby mode.

**Table 2. Functionalities depending on the operating power supply range**

Operating power supply range	Functionalities depending on the operating power supply range			
	DAC and ADC operation	USB	Dynamic voltage scaling range	I/O operation
$V_{DD} = 1.8$ to $2.0$ V	Conversion time up to 500 Ksps	Not functional	Range 2 or Range 3	Degraded speed performance
$V_{DD} = 2.0$ to $2.4$ V	Conversion time up to 500 Ksps	Functional <sup>(1)</sup>	Range 1, Range 2 or Range 3	Full speed operation
$V_{DD} = 2.4$ to $3.6$ V	Conversion time up to 1 Msps	Functional <sup>(1)</sup>	Range 1, Range 2 or Range 3	Full speed operation

1. Should be USB-compliant from I/O voltage standpoint, the minimum  $V_{DD}$  is 3.0 V.

**Table 3. CPU frequency range depending on dynamic voltage scaling**

<b>CPU frequency range</b>	<b>Dynamic voltage scaling range</b>
16 MHz to 32 MHz (1ws) 32 kHz to 16 MHz (0ws)	Range 1
8 MHz to 16 MHz (1ws) 32 kHz to 8 MHz (0ws)	Range 2
2.1 MHz to 4.2 MHz (1ws) 32 kHz to 2.1 MHz (0ws)	Range 3



**Table 4. Working mode-dependent functionalities (from Run/active down to standby)**

Ips	Run/Active	Sleep	Low-power Run	Low-power Sleep	Stop		Standby	
					Wakeup capability	Wakeup capability		
CPU	Y	-	Y	-	-	-	-	-
Flash	Y	Y	Y	-	-	-	-	-
RAM	Y	Y	Y	Y	Y	-	-	-
Backup Registers	Y	Y	Y	Y	Y	-	Y	-
EEPROM	Y	Y	Y	Y	Y	-	-	-
Brown-out reset (BOR)	Y	Y	Y	Y	Y	Y	Y	-
DMA	Y	Y	Y	Y	-	-	-	-
Programmable Voltage Detector (PVD)	Y	Y	Y	Y	Y	Y	Y	-
Power On Reset (POR)	Y	Y	Y	Y	Y	Y	Y	-
Power Down Rest (PDR)	Y	Y	Y	Y	Y	-	Y	-
High Speed Internal (HSI)	Y	Y	-	-	-	-	-	-
High Speed External (HSE)	Y	Y	-	-	-	-	-	-
Low Speed Internal (LSI)	Y	Y	Y	Y	Y	-	Y	-
Low Speed External (LSE)	Y	Y	Y	Y	Y	-	Y	-
Multi-Speed Internal (MSI)	Y	Y	Y	Y	-	-	-	-
Inter-Connect Controller	Y	Y	Y	Y	-	-	-	-
RTC	Y	Y	Y	Y	Y	Y	Y	-
RTC Tamper	Y	Y	Y	Y	Y	Y	Y	Y
Auto Wakeup (AWU)	Y	Y	Y	Y	Y	Y	Y	Y
LCD	Y	Y	Y	Y	Y	-	-	-
USB	Y	Y	-	-	-	Y	-	-
USART	Y	Y	Y	Y	Y	(1)	-	-
SPI	Y	Y	Y	Y	-	-	-	-
I2C	Y	Y	Y	Y	-	(1)	-	-
ADC	Y	Y	-	-	-	-	-	-

**Table 4. Working mode-dependent functionalities (from Run/active down to standby) (continued)**

Ips	Run/Active	Sleep	Low-power Run	Low-power Sleep	Stop		Standby	
					Wakeup capability	Wakeup capability		
DAC	Y	Y	Y	Y	Y	-	-	-
Comparators	Y	Y	Y	Y	Y	Y	-	-
16-bit Timers	Y	Y	Y	Y	-	-	-	-
IWDG	Y	Y	Y	Y	Y	Y	Y	Y
WWDG	Y	Y	Y	Y	-	-	-	-
Systick Timer	Y	Y	Y	Y	-	-	-	-
GPIOs	Y	Y	Y	Y	Y	Y	-	2 pins
Wakeup time to Run mode	0 μs	0.4 μs	3 μs	46 μs	< 8 μs		58 μs	
Consumption V <sub>DD</sub> =1.8V to 3.6V (Typ)	Down to 214 μA/MHz (from Flash)	Down to 50 μA/MHz (from Flash)	Down to 9 μA	Down to 4.4 μA	0.65 μA (No RTC) V <sub>DD</sub> =1.8 V		0.3 μA (No RTC) V <sub>DD</sub> =1.8 V	
					1.4 μA (with RTC) V <sub>DD</sub> =1.8 V		1 μA (with RTC) V <sub>DD</sub> =1.8 V	
					0.65 μA (No RTC) V <sub>DD</sub> =3.0 V		0.3 μA (No RTC) V <sub>DD</sub> =3.0 V	
					1.6 μA (with RTC) V <sub>DD</sub> =3.0 V		1.3 μA (with RTC) V <sub>DD</sub> =3.0 V	

1. The startup on communication line wakes the CPU which was made possible by an EXTI, this induces a delay before entering run mode.

### 3.2 ARM<sup>®</sup> Cortex<sup>®</sup>-M3 core with MPU

The ARM<sup>®</sup> Cortex<sup>®</sup>-M3 processor is the industry leading processor for embedded systems. It has been developed to provide a low-cost platform that meets the needs of MCU implementation, with a reduced pin count and low-power consumption, while delivering outstanding computational performance and an advanced system response to interrupts.

The ARM<sup>®</sup> Cortex<sup>®</sup>-M3 32-bit RISC processor features exceptional code-efficiency, delivering the high-performance expected from an ARM core in the memory size usually associated with 8- and 16-bit devices.

The memory protection unit (MPU) improves system reliability by defining the memory attributes (such as read/write access permissions) for different memory regions. It provides up to eight different regions and an optional predefined background region.

Owing to its embedded ARM core, the STM32L100C6 and STM32L100R8/RB devices are compatible with all ARM tools and software.

### Nested vectored interrupt controller (NVIC)

The ultra-low-power STM32L100C6 and STM32L100R8/RB devices embed a nested vectored interrupt controller able to handle up to 45 maskable interrupt channels (not including the 16 interrupt lines of Cortex-M3) and 16 priority levels.

- Closely coupled NVIC gives low-latency interrupt processing
- Interrupt entry vector table address passed directly to the core
- Closely coupled NVIC core interface
- Allows early processing of interrupts
- Processing of *late arriving*, higher-priority interrupts
- Support for tail-chaining
- Processor state automatically saved
- Interrupt entry restored on interrupt exit with no instruction overhead

This hardware block provides flexible interrupt management features with minimal interrupt latency.

## 3.3 Reset and supply management

### 3.3.1 Power supply schemes

- $V_{DD} = 1.8$  to  $3.6$  V: external power supply for I/Os and the internal regulator. Provided externally through  $V_{DD}$  pins.
- $V_{SSA}$ ,  $V_{DDA} = 1.8$  to  $3.6$  V: external analog power supplies for ADC, reset blocks, RCs and PLL.  
 $V_{DDA}$  and  $V_{SSA}$  must be connected to  $V_{DD}$  and  $V_{SS}$ , respectively.

### 3.3.2 Power supply supervisor

The device has an integrated ZEROPOWER power-on reset (POR)/power-down reset (PDR) that can be coupled with a brownout reset (BOR) circuitry.

BOR is activated at power-on and the device operates between  $1.8$  V and  $3.6$  V.

After the  $V_{DD}$  threshold is reached, the option byte loading process starts, either to confirm or modify default thresholds, or to disable the BOR permanently.

BOR ensures proper operation starting from  $1.8$  V whatever the power ramp-up phase before it reaches  $1.8$  V.

Five BOR thresholds are available through option bytes, starting from 1.8 V to 3 V. To reduce the power consumption in Stop mode, it is possible to automatically switch off the internal reference voltage ( $V_{REFINT}$ ) in Stop mode. The device remains in reset mode when  $V_{DD}$  is below a specified threshold,  $V_{POR/PDR}$  or  $V_{BOR}$ , without the need for any external reset circuit.

The device features an embedded programmable voltage detector (PVD) that monitors the  $V_{DD}/V_{DDA}$  power supply and compares it to the  $V_{PVD}$  threshold. This PVD offers 7 different levels between 1.85 V and 3.05 V, chosen by software, with a step around 200 mV. An interrupt can be generated when  $V_{DD}/V_{DDA}$  drops below the  $V_{PVD}$  threshold and/or when  $V_{DD}/V_{DDA}$  is higher than the  $V_{PVD}$  threshold. The interrupt service routine can then generate a warning message and/or put the MCU into a safe state. The PVD is enabled by software.

### 3.3.3 Voltage regulator

The regulator has three operation modes: main (MR), low-power (LPR) and power down.

- MR is used in Run mode (nominal regulation)
- LPR is used in the Low-power run, Low-power sleep and Stop modes
- Power down is used in Standby mode. The regulator output is high impedance, the kernel circuitry is powered down, inducing zero consumption but the contents of the registers and RAM are lost except for the standby circuitry (wake-up logic, IWDG, RTC, LSI, LSE crystal 32K osc, RCC\_CSR).

### 3.3.4 Boot modes

At startup, boot pins are used to select one of three boot options:

- Boot from Flash memory
- Boot from System Memory
- Boot from embedded RAM

The boot loader is located in System Memory. It is used to reprogram the Flash memory by using USART1 or USART2. See the application note "STM32 microcontroller system memory boot mode" (AN2606) for details.

The HSI oscillator is to be calibrated to +/-1% before using of the bootloader.

## 3.4 Clock management

The clock controller distributes the clocks coming from different oscillators to the core and the peripherals. It also manages clock gating for low-power modes and ensures clock robustness. It features:

- **Clock prescaler:** to get the best trade-off between speed and current consumption, the clock frequency to the CPU and peripherals can be adjusted by a programmable prescaler
- **Safe clock switching:** clock sources can be changed safely on the fly in run mode through a configuration register.
- **Clock management:** to reduce power consumption, the clock controller can stop the clock to the core, individual peripherals or memory.
- **Master clock source:** three different clock sources can be used to drive the master clock:
  - 1-24 MHz high-speed external crystal (HSE), that can supply a PLL
  - 16 MHz high-speed internal RC oscillator (HSI), trimmable by software, that can supply a PLL
  - Multispeed internal RC oscillator (MSI), trimmable by software, able to generate 7 frequencies (65.5 kHz, 131 kHz, 262 kHz, 524 kHz, 1.05 MHz, 2.1 MHz, 4.2 MHz) with a consumption proportional to speed, down to 750 nA typical. When a 32.768 kHz clock source is available in the system (LSE), the MSI frequency can be trimmed by software down to a  $\pm 0.5\%$  accuracy.
- **Auxiliary clock source:** two ultra-low-power clock sources that can be used to drive the LCD controller and the real-time clock:
  - 32.768 kHz low-speed external crystal (LSE)
  - 37 kHz low-speed internal RC (LSI), also used to drive the independent watchdog. The LSI clock can be measured using the high-speed internal RC oscillator for greater precision.
- **RTC and LCD clock sources:** the LSI, LSE or HSE sources can be chosen to clock the RTC and the LCD, whatever the system clock.
- **USB clock source:** the embedded PLL has a dedicated 48 MHz clock output to supply the USB interface.
- **Startup clock:** after reset, the microcontroller restarts by default with an internal 2.1 MHz clock (MSI). The prescaler ratio and clock source can be changed by the application program as soon as the code execution starts.
- **Clock security system (CSS):** this feature can be enabled by software. If a HSE clock failure occurs, the master clock is automatically switched to HSI and a software interrupt is generated if enabled.
- **Clock-out capability (MCO: microcontroller clock output):** it outputs one of the internal clocks for external use by the application.

Several prescalers allow the configuration of the AHB frequency, the high-speed APB (APB2) and the low-speed APB (APB1) domains. The maximum frequency of the AHB and the APB domains is 32 MHz. See [Figure 2](#) for details on the clock tree.

Figure 2. Clock tree

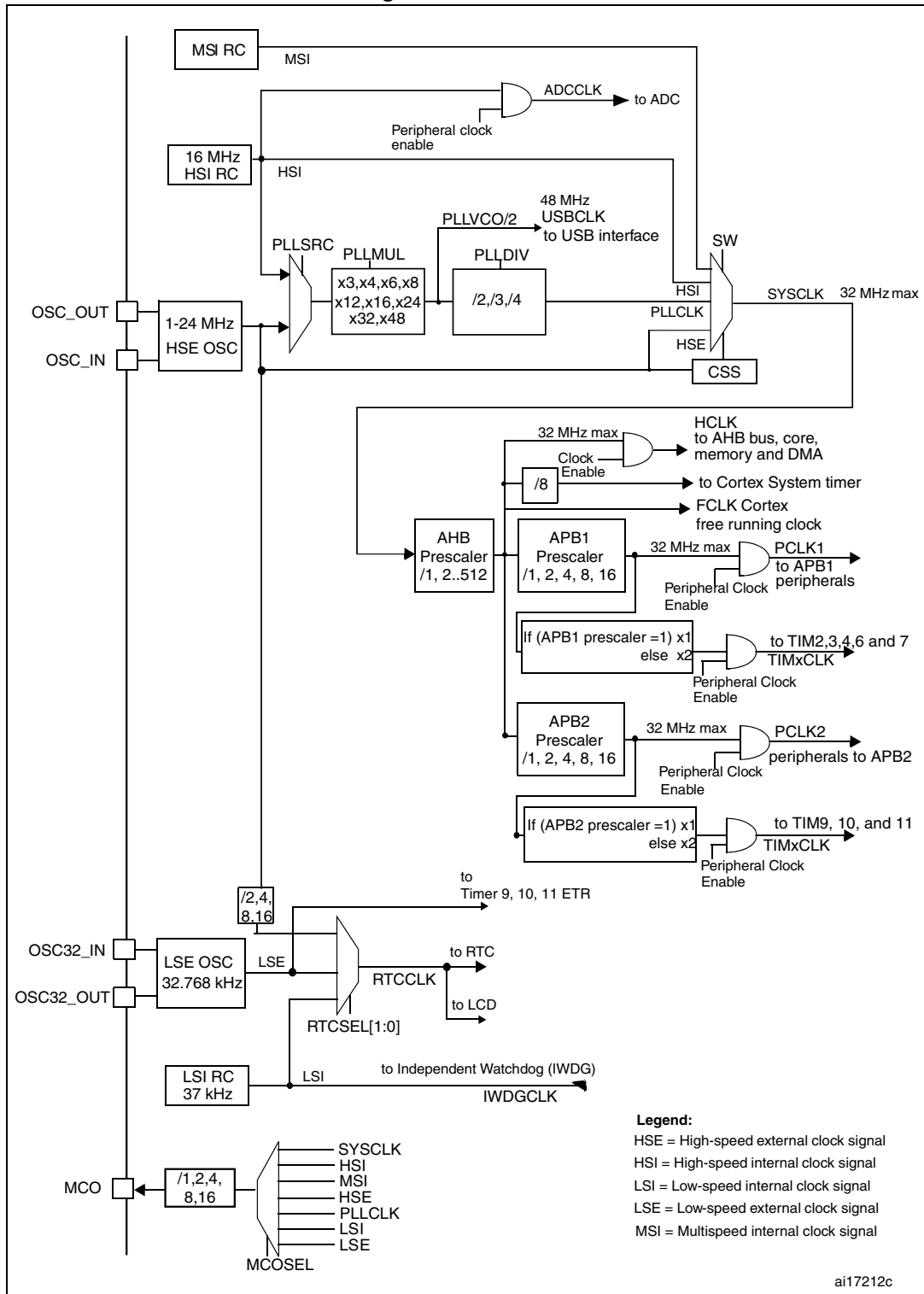

### 3.5 Low-power real-time clock and backup registers

The real-time clock (RTC) is an independent BCD timer/counter. Dedicated registers contain the sub-second, second, minute, hour (12/24 hour), week day, date, month, year, in BCD (binary-coded decimal) format. Correction for 28, 29 (leap year), 30, and 31 day of the month are made automatically. The RTC provides two programmable alarms and programmable periodic interrupts with wakeup from Stop and Standby modes.

The programmable wakeup time ranges from 120  $\mu$ s to 36 hours.

The RTC can be calibrated with an external 512 Hz output, and a digital compensation circuit helps reduce drift due to crystal deviation. The RTC can also be automatically corrected with a 50/60Hz stable power line.

The RTC calendar can be updated on the fly down to sub second precision, which enables network system synchronization. A time stamp can record an external event occurrence, and generates an interrupt.

There are five 32-bit backup registers provided to store 20 bytes of user application data. They are cleared in case of tamper detection. Three pins can be used to detect tamper events. A change on one of these pins can reset backup register and generate an interrupt. To prevent false tamper event, like ESD event, these three tamper inputs can be digitally filtered.

### 3.6 GPIOs (general-purpose inputs/outputs)

Each of the GPIO pins can be configured by software as output (push-pull or open-drain), as input (with or without pull-up or pull-down) or as peripheral alternate function. Most of the GPIO pins are shared with digital or analog alternate functions, and can be individually remapped using dedicated AFIO registers. All GPIOs are high current capable. The alternate function configuration of I/Os can be locked if needed following a specific sequence in order to avoid spurious writing to the I/O registers. The I/O controller is connected to the AHB with a toggling speed of up to 16 MHz.

#### External interrupt/event controller (EXTI)

The external interrupt/event controller consists of 23 edge detector lines used to generate interrupt/event requests. Each line can be individually configured to select the trigger event (rising edge, falling edge, both) and can be masked independently. A pending register maintains the status of the interrupt requests. The EXTI can detect an external line with a pulse width shorter than the Internal APB2 clock period. Up to 51 GPIOs can be connected to the 16 external interrupt lines. The 7 other lines are connected to RTC, PVD, USB or Comparator events.

## 3.7 Memories

The STM32L100C6 and STM32L100R8/RB devices have the following features:

- Up to 10 Kbytes of embedded RAM accessed (read/write) at CPU clock speed with 0 wait states. With the enhanced bus matrix, operating the RAM does not lead to any performance penalty during accesses to the system bus (AHB and APB buses).
- The non-volatile memory is divided into three arrays:
  - 32, 64 or 128 Kbytes of embedded Flash program memory
  - 2 Kbytes of data EEPROM
  - Options bytes

The options bytes are used to write-protect the memory (with 4 Kbytes granularity) and/or readout-protect the whole memory with the following options:

- Level 0: no readout protection
- Level 1: memory readout protection, the Flash memory cannot be read from or written to if either debug features are connected or boot in RAM is selected
- Level 2: chip readout protection, debug features (Cortex-M3 JTAG and serial wire) and boot in RAM selection disabled (JTAG fuse)

The whole non-volatile memory embeds the error correction code (ECC) feature.

## 3.8 DMA (direct memory access)

The flexible 7-channel, general-purpose DMA is able to manage memory-to-memory, peripheral-to-memory and memory-to-peripheral transfers. The DMA controller supports circular buffer management, avoiding the generation of interrupts when the controller reaches the end of the buffer.

Each channel is connected to dedicated hardware DMA requests, with software trigger support for each channel. Configuration is done by software and transfer sizes between source and destination are independent.

The DMA can be used with the main peripherals: SPI, I<sup>2</sup>C, USART, general-purpose timers and ADC.

## 3.9 LCD (liquid crystal display)

The LCD drives up to 8 common terminals and 32 segment terminals to drive up to 224 pixels.

- Internal step-up converter to guarantee functionality and contrast control irrespective of  $V_{DD}$ . This converter can be deactivated, in which case the  $V_{LCD}$  pin is used to provide the voltage to the LCD
- Supports static, 1/2, 1/3, 1/4 and 1/8 duty
- Supports static, 1/2, 1/3 and 1/4 bias
- Phase inversion to reduce power consumption and EMI
- Up to 8 pixels can be programmed to blink
- Unneeded segments and common pins can be used as general I/O pins
- LCD RAM can be updated at any time owing to a double-buffer
- The LCD controller can operate in Stop mode



## 3.10 ADC (analog-to-digital converter)

A 12-bit analog-to-digital converters is embedded into STM32L100C6 and STM32L100R8/RB devices with up to 20 external channels, performing conversions in single-shot or scan mode. In scan mode, automatic conversion is performed on a selected group of analog inputs.

The ADC can be served by the DMA controller.

An analog watchdog feature allows very precise monitoring of the converted voltage of one, some or all selected channels. An interrupt is generated when the converted voltage is outside the programmed thresholds.

The events generated by the general-purpose timers (TIMx) can be internally connected to the ADC start trigger and injection trigger, to allow the application to synchronize A/D conversions and timers. An injection mode allows high priority conversions to be done by interrupting a scan mode which runs in as a background task.

The ADC includes a specific low-power mode. The converter is able to operate at maximum speed even if the CPU is operating at a very low frequency and has an auto-shutdown function. The ADC's runtime and analog front-end current consumption are thus minimized whatever the MCU operating mode.

### 3.10.1 Internal voltage reference ( $V_{REFINT}$ )

The internal voltage reference ( $V_{REFINT}$ ) provides a stable (bandgap) voltage output for the ADC and Comparators.  $V_{REFINT}$  is internally connected to the ADC\_IN17 input channel. It enables accurate monitoring of the  $V_{DD}$  value. The precise voltage of  $V_{REFINT}$  is individually measured for each part by ST during production test and stored in the system memory area. It is accessible in read-only mode see [Table 15: Embedded internal reference voltage](#).

## 3.11 DAC (digital-to-analog converter)

The two 12-bit buffered DAC channels can be used to convert two digital signals into two analog voltage signal outputs. The chosen design structure is composed of integrated resistor strings and an amplifier in non-inverting configuration.

This dual digital Interface supports the following features:

- two DAC converters: one for each output channel
- left or right data alignment in 12-bit mode
- synchronized update capability
- noise-wave generation
- triangular-wave generation
- dual DAC channels' independent or simultaneous conversions
- DMA capability for each channel (including the underrun interrupt)
- external triggers for conversion

Eight DAC trigger inputs are used in the STM32L100C6 and STM32L100R8/RB devices. The DAC channels are triggered through the timer update outputs that are also connected to different DMA channels.

### 3.12 Ultra-low-power comparators and reference voltage

The STM32L100C6 and STM32L100R8/RB devices embed two comparators sharing the same current bias and reference voltage. The reference voltage can be internal or external (coming from an I/O).

- one comparator with fixed threshold
- one comparator with rail-to-rail inputs, fast or slow mode. The threshold can be one of the following:
  - DAC output
  - External I/O
  - Internal reference voltage ( $V_{REFINT}$ ) or  $V_{REFINT}$  submultiple (1/4, 1/2, 3/4)

Both comparators can wake up from Stop mode, and be combined into a window comparator.

The internal reference voltage is available externally via a low-power / low-current output buffer (driving current capability of 1  $\mu$ A typical).

### 3.13 Routing interface

This interface controls the internal routing of I/Os to TIM2, TIM3, TIM4 and to the comparator and reference voltage output.

### 3.14 Timers and watchdogs

The ultra-low-power STM32L100C6 and STM32L100R8/RB devices include six general-purpose timers, two basic timers and two watchdog timers.

[Table 5](#) compares the features of the general-purpose and basic timers.

**Table 5. Timer feature comparison**

Timer	Counter resolution	Counter type	Prescaler factor	DMA request generation	Capture/compare channels	Complementary outputs
TIM2, TIM3, TIM4	16-bit	Up, down, up/down	Any integer between 1 and 65536	Yes	4	No
TIM9	16-bit	Up, down, up/down	Any integer between 1 and 65536	No	2	No
TIM10, TIM11	16-bit	Up	Any integer between 1 and 65536	No	1	No
TIM6, TIM7	16-bit	Up	Any integer between 1 and 65536	Yes	0	No