



Chipsmall Limited consists of a professional team with an average of over 10 year of expertise in the distribution of electronic components. Based in Hongkong, we have already established firm and mutual-benefit business relationships with customers from,Europe,America and south Asia,supplying obsolete and hard-to-find components to meet their specific needs.

With the principle of “Quality Parts,Customers Priority,Honest Operation,and Considerate Service”,our business mainly focus on the distribution of electronic components. Line cards we deal with include Microchip,ALPS,ROHM,Xilinx,Pulse,ON,Everlight and Freescale. Main products comprise IC,Modules,Potentiometer,IC Socket,Relay,Connector.Our parts cover such applications as commercial,industrial, and automotives areas.

We are looking forward to setting up business relationship with you and hope to provide you with the best service and solution. Let us make a better world for our industry!



## Contact us

Tel: +86-755-8981 8866 Fax: +86-755-8427 6832

Email & Skype: info@chipsmall.com Web: www.chipsmall.com

Address: A1208, Overseas Decoration Building, #122 Zhenhua RD., Futian, Shenzhen, China



## Ultra-low-power 32-bit MCU ARM<sup>®</sup>-based Cortex<sup>®</sup>-M3 with 512KB Flash, 80KB SRAM, 16KB EEPROM, LCD, USB, ADC, DAC

Datasheet - production data

### Features

- Ultra-low-power platform
  - 1.65 V to 3.6 V power supply
  - **-40 °C to 105 °C** temperature range
  - 290 nA Standby mode (3 wakeup pins)
  - **1.11 µA Standby mode + RTC**
  - 560 nA Stop mode (16 wakeup lines)
  - 1.4 µA Stop mode + RTC
  - 11 µA Low-power run mode down to 4.6 µA in Low-power sleep mode
  - 195 µA/MHz Run mode
  - 10 nA ultra-low I/O leakage
  - 8 µs wakeup time
- Core: ARM<sup>®</sup> Cortex<sup>®</sup>-M3 32-bit CPU
  - From 32 kHz up to 32 MHz max
  - 1.25 DMIPS/MHz (Dhrystone 2.1)
  - Memory protection unit
- Up to 34 capacitive sensing channels
- CRC calculation unit, 96-bit unique ID
- Reset and supply management
  - Low-power, ultrasafe BOR (brownout reset) with 5 selectable thresholds
  - Ultra-low-power POR/PDR
  - Programmable voltage detector (PVD)
- Clock sources
  - 1 to 24 MHz crystal oscillator
  - 32 kHz oscillator for RTC with calibration
  - Internal 16 MHz oscillator factory trimmed RC(+/-1%) with PLL option
  - Internal low-power 37 kHz oscillator
  - Internal multispeed low-power 65 kHz to 4.2 MHz oscillator
  - PLL for CPU clock and USB (48 MHz)
- Pre-programmed bootloader
  - USB and USART supported

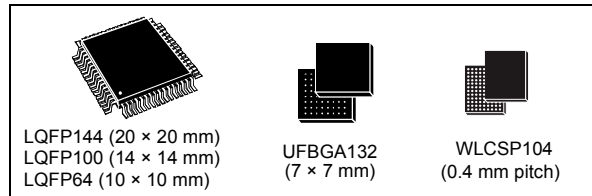

- Up to 116 fast I/Os (102 I/Os 5V tolerant), all mappable on 16 external interrupt vectors
- Memories
  - 512 KB Flash memory with ECC (with 2 banks of 256 KB enabling RWW capability)
  - 80 KB RAM
  - 16 KB of true EEPROM with ECC
  - 128 Byte backup register
- LCD driver (except STM32L151xE devices) up to 8x40 segments, contrast adjustment, blinking mode, step-up converter
- Rich analog peripherals (down to 1.8 V)
  - 2x operational amplifiers
  - 12-bit ADC 1 Msps up to 40 channels
  - 12-bit DAC 2 ch with output buffers
  - 2x ultra-low-power comparators (window mode and wake up capability)
- DMA controller 12x channels
- 11x peripheral communication interfaces
  - 1x USB 2.0 (internal 48 MHz PLL)
  - 5x USARTs
  - Up to 8x SPIs (2x I2S, 3x 16 Mbit/s)
  - 2x I<sup>2</sup>Cs (SMBus/PMBus)
- 11x timers: 1x 32-bit, 6x 16-bit with up to 4 IC/OC/PWM channels, 2x 16-bit basic timers, 2x watchdog timers (independent and window)
- Development support: serial wire debug, JTAG and trace

**Table 1. Device summary**

Reference	Part number
STM32L151xE	STM32L151QE, STM32L151RE, STM32L151VE, STM32L151ZE
STM32L152xE	STM32L152QE, STM32L152RE, STM32L152VE, STM32L152ZE

# Contents

<b>1</b>	<b>Introduction</b>	<b>9</b>
<b>2</b>	<b>Description</b>	<b>10</b>
2.1	Device overview	11
2.2	Ultra-low-power device continuum	12
2.2.1	Performance	12
2.2.2	Shared peripherals	12
2.2.3	Common system strategy	12
2.2.4	Features	12
<b>3</b>	<b>Functional overview</b>	<b>13</b>
3.1	Low-power modes	14
3.2	ARM <sup>®</sup> Cortex <sup>®</sup> -M3 core with MPU	18
3.3	Reset and supply management	19
3.3.1	Power supply schemes	19
3.3.2	Power supply supervisor	19
3.3.3	Voltage regulator	20
3.3.4	Boot modes	20
3.4	Clock management	21
3.5	Low-power real-time clock and backup registers	23
3.6	GPIOs (general-purpose inputs/outputs)	23
3.7	Memories	24
3.8	DMA (direct memory access)	24
3.9	LCD (liquid crystal display)	25
3.10	ADC (analog-to-digital converter)	25
3.10.1	Temperature sensor	25
3.10.2	Internal voltage reference ( $V_{REFINT}$ )	26
3.11	DAC (digital-to-analog converter)	26
3.12	Operational amplifier	26
3.13	Ultra-low-power comparators and reference voltage	27
3.14	System configuration controller and routing interface	27
3.15	Touch sensing	27

- 3.16 Timers and watchdogs ..... 28
  - 3.16.1 General-purpose timers (TIM2, TIM3, TIM4, TIM5, TIM9, TIM10 and TIM11) ..... 28
  - 3.16.2 Basic timers (TIM6 and TIM7) ..... 29
  - 3.16.3 SysTick timer ..... 29
  - 3.16.4 Independent watchdog (IWDG) ..... 29
  - 3.16.5 Window watchdog (WWDG) ..... 29
- 3.17 Communication interfaces ..... 29
  - 3.17.1 I<sup>2</sup>C bus ..... 29
  - 3.17.2 Universal synchronous/asynchronous receiver transmitter (USART) .. 29
  - 3.17.3 Serial peripheral interface (SPI) ..... 30
  - 3.17.4 Inter-integrated sound (I2S) ..... 30
  - 3.17.5 Universal serial bus (USB) ..... 30
- 3.18 CRC (cyclic redundancy check) calculation unit ..... 30
- 3.19 Development support ..... 31
  - 3.19.1 Serial wire JTAG debug port (SWJ-DP) ..... 31
  - 3.19.2 Embedded Trace Macrocell™ ..... 31
- 4 Pin descriptions ..... 32**
- 5 Memory mapping ..... 55**
- 6 Electrical characteristics ..... 56**
  - 6.1 Parameter conditions ..... 56
    - 6.1.1 Minimum and maximum values ..... 56
    - 6.1.2 Typical values ..... 56
    - 6.1.3 Typical curves ..... 56
    - 6.1.4 Loading capacitor ..... 56
    - 6.1.5 Pin input voltage ..... 56
    - 6.1.6 Power supply scheme ..... 57
    - 6.1.7 Optional LCD power supply scheme ..... 58
    - 6.1.8 Current consumption measurement ..... 58
  - 6.2 Absolute maximum ratings ..... 59
  - 6.3 Operating conditions ..... 60
    - 6.3.1 General operating conditions ..... 60
    - 6.3.2 Embedded reset and power control block characteristics ..... 61
    - 6.3.3 Embedded internal reference voltage ..... 63

6.3.4	Supply current characteristics	64
6.3.5	Wakeup time from low-power mode	75
6.3.6	External clock source characteristics	76
6.3.7	Internal clock source characteristics	81
6.3.8	PLL characteristics	84
6.3.9	Memory characteristics	84
6.3.10	EMC characteristics	86
6.3.11	Electrical sensitivity characteristics	87
6.3.12	I/O current injection characteristics	88
6.3.13	I/O port characteristics	89
6.3.14	NRST pin characteristics	92
6.3.15	TIM timer characteristics	93
6.3.16	Communications interfaces	94
6.3.17	12-bit ADC characteristics	102
6.3.18	DAC electrical specifications	107
6.3.19	Operational amplifier characteristics	109
6.3.20	Temperature sensor characteristics	111
6.3.21	Comparator	111
6.3.22	LCD controller	113
<b>7</b>	<b>Package information</b>	<b>114</b>
7.1	LQFP144, 20 x 20 mm, 144-pin low-profile quad flat package information	114
7.2	LQFP100, 14 x 14 mm, 100-pin low-profile quad flat package information	117
7.3	LQFP64, 10 x 10 mm, 64-pin low-profile quad flat package information	120
7.4	UFBGA132, 7 x 7 mm, 132-ball ultra thin, fine-pitch ball grid array package information	123
7.5	WLCSP104, 0.4 mm pitch wafer level chip scale package information	126
7.6	Thermal characteristics	129
7.6.1	Reference document	130
<b>8</b>	<b>Part numbering</b>	<b>131</b>
<b>9</b>	<b>Revision History</b>	<b>132</b>

## List of tables

Table 1.	Device summary . . . . .	1
Table 2.	Ultra-low-power STM32L151xE and STM32L152xE device features and peripheral counts . . . . .	11
Table 3.	Functionalities depending on the operating power supply range . . . . .	15
Table 4.	CPU frequency range depending on dynamic voltage scaling . . . . .	16
Table 5.	Functionalities depending on the working mode (from Run/active down to standby) . . . . .	17
Table 6.	Timer feature comparison . . . . .	28
Table 7.	Legend/abbreviations used in the pinout table . . . . .	36
Table 8.	STM32L151xE and STM32L152xE pin definitions . . . . .	37
Table 9.	Alternate function input/output . . . . .	46
Table 10.	Voltage characteristics . . . . .	59
Table 11.	Current characteristics . . . . .	59
Table 12.	Thermal characteristics . . . . .	60
Table 13.	General operating conditions . . . . .	60
Table 14.	Embedded reset and power control block characteristics . . . . .	61
Table 15.	Embedded internal reference voltage calibration values . . . . .	63
Table 16.	Embedded internal reference voltage . . . . .	63
Table 17.	Current consumption in Run mode, code with data processing running from Flash. . . . .	65
Table 18.	Current consumption in Run mode, code with data processing running from RAM . . . . .	66
Table 19.	Current consumption in Sleep mode . . . . .	67
Table 20.	Current consumption in Low-power run mode . . . . .	68
Table 21.	Current consumption in Low-power sleep mode . . . . .	69
Table 22.	Typical and maximum current consumptions in Stop mode . . . . .	70
Table 23.	Typical and maximum current consumptions in Standby mode . . . . .	72
Table 24.	Peripheral current consumption . . . . .	73
Table 25.	Low-power mode wakeup timings . . . . .	75
Table 26.	High-speed external user clock characteristics . . . . .	76
Table 27.	Low-speed external user clock characteristics . . . . .	77
Table 28.	HSE oscillator characteristics . . . . .	78
Table 29.	LSE oscillator characteristics ( $f_{LSE} = 32.768$ kHz) . . . . .	79
Table 30.	HSI oscillator characteristics . . . . .	81
Table 31.	LSI oscillator characteristics . . . . .	81
Table 32.	MSI oscillator characteristics . . . . .	82
Table 33.	PLL characteristics . . . . .	84
Table 34.	RAM and hardware registers . . . . .	84
Table 35.	Flash memory and data EEPROM characteristics . . . . .	85
Table 36.	Flash memory and data EEPROM endurance and retention . . . . .	85
Table 37.	EMS characteristics . . . . .	86
Table 38.	EMI characteristics . . . . .	87
Table 39.	ESD absolute maximum ratings . . . . .	87
Table 40.	Electrical sensitivities . . . . .	88
Table 41.	I/O current injection susceptibility . . . . .	88
Table 42.	I/O static characteristics . . . . .	89
Table 43.	Output voltage characteristics . . . . .	90
Table 44.	I/O AC characteristics . . . . .	91
Table 45.	NRST pin characteristics . . . . .	92
Table 46.	TIMx characteristics . . . . .	93

Table 47.	I <sup>2</sup> C characteristics . . . . .	94
Table 48.	SCL frequency ( $f_{PCLK1} = 32$ MHz, $V_{DD} = V_{DD\_I2C} = 3.3$ V) . . . . .	95
Table 49.	SPI characteristics . . . . .	96
Table 50.	USB startup time . . . . .	99
Table 51.	USB DC electrical characteristics . . . . .	99
Table 52.	USB: full speed electrical characteristics . . . . .	99
Table 53.	I2S characteristics . . . . .	100
Table 54.	ADC clock frequency . . . . .	102
Table 55.	ADC characteristics . . . . .	102
Table 56.	ADC accuracy . . . . .	104
Table 57.	Maximum source impedance $R_{AIN}$ max . . . . .	106
Table 58.	DAC characteristics . . . . .	107
Table 59.	Operational amplifier characteristics . . . . .	109
Table 60.	Temperature sensor calibration values . . . . .	111
Table 61.	Temperature sensor characteristics . . . . .	111
Table 62.	Comparator 1 characteristics . . . . .	111
Table 63.	Comparator 2 characteristics . . . . .	112
Table 64.	LCD controller characteristics . . . . .	113
Table 65.	LQFP144, 20 x 20 mm, 144-pin low-profile quad flat package mechanical data . . . . .	115
Table 66.	LQPF100, 14 x 14 mm, 100-pin low-profile quad flat package mechanical data . . . . .	117
Table 67.	LQFP64, 10 x 10 mm 64-pin low-profile quad flat package mechanical data . . . . .	120
Table 68.	UFBGA132, 7 x 7 mm, 132-ball ultra thin, fine-pitch ball grid array package mechanical data . . . . .	123
Table 69.	WLCSP104, 0.4 mm pitch wafer level chip scale package mechanical data . . . . .	127
Table 70.	WLCSP104, 0.4 mm pitch recommended PCB design rules . . . . .	128
Table 71.	Thermal characteristics . . . . .	129
Table 72.	STM32L151xE and STM32L152xE Ordering information scheme . . . . .	131
Table 73.	Document revision history . . . . .	132

## List of figures

Figure 1.	Ultra-low-power STM32L151xE and STM32L152xE block diagram. . . . .	13
Figure 2.	Clock tree . . . . .	22
Figure 3.	STM32L15xZE LQFP144 pinout. . . . .	32
Figure 4.	STM32L15xQE UFBGA132 ballout . . . . .	33
Figure 5.	STM32L15xVE LQFP100 pinout . . . . .	34
Figure 6.	STM32L15xRE LQFP64 pinout . . . . .	35
Figure 7.	STM32L15xVEY WLCSP104 ballout . . . . .	36
Figure 8.	Memory map . . . . .	55
Figure 9.	Pin loading conditions. . . . .	56
Figure 10.	Pin input voltage . . . . .	56
Figure 11.	Power supply scheme. . . . .	57
Figure 12.	Optional LCD power supply scheme . . . . .	58
Figure 13.	Current consumption measurement scheme . . . . .	58
Figure 14.	High-speed external clock source AC timing diagram . . . . .	76
Figure 15.	Low-speed external clock source AC timing diagram . . . . .	77
Figure 16.	HSE oscillator circuit diagram. . . . .	79
Figure 17.	Typical application with a 32.768 kHz crystal . . . . .	80
Figure 18.	I/O AC characteristics definition . . . . .	92
Figure 19.	Recommended NRST pin protection . . . . .	93
Figure 20.	I <sup>2</sup> C bus AC waveforms and measurement circuit. . . . .	95
Figure 21.	SPI timing diagram - slave mode and CPHA = 0 . . . . .	97
Figure 22.	SPI timing diagram - slave mode and CPHA = 1 <sup>(1)</sup> . . . . .	97
Figure 23.	SPI timing diagram - master mode <sup>(1)</sup> . . . . .	98
Figure 24.	USB timings: definition of data signal rise and fall time . . . . .	99
Figure 25.	I <sup>2</sup> S slave timing diagram (Philips protocol) <sup>(1)</sup> . . . . .	101
Figure 26.	I <sup>2</sup> S master timing diagram (Philips protocol) <sup>(1)</sup> . . . . .	101
Figure 27.	ADC accuracy characteristics. . . . .	105
Figure 28.	Typical connection diagram using the ADC . . . . .	105
Figure 29.	Maximum dynamic current consumption on V <sub>REF+</sub> supply pin during ADC conversion . . . . .	106
Figure 30.	12-bit buffered /non-buffered DAC . . . . .	109
Figure 31.	LQFP144, 20 x 20 mm, 144-pin low-profile quad flat package outline . . . . .	114
Figure 32.	LQFP144, 20 x 20 mm, 144-pin low-profile quad flat package recommended footprint. . . . .	116
Figure 33.	LQFP144, 20 x 20 mm, 144-pin low-profile quad flat package top view example . . . . .	116
Figure 34.	LQFP100, 14 x 14 mm, 100-pin low-profile quad flat package outline . . . . .	117
Figure 35.	LQFP100, 14 x 14 mm, 100-pin low-profile quad flat package recommended footprint. . . . .	118
Figure 36.	LQFP100, 14 x 14 mm, 100-pin low-profile quad flat package top view example . . . . .	119
Figure 37.	LQFP64, 10 x 10 mm, 64-pin low-profile quad flat package outline . . . . .	120
Figure 38.	LQFP64, 10 x 10 mm, 64-pin low-profile quad flat package recommended footprint. . . . .	121
Figure 39.	LQFP64 10 x 10 mm, 64-pin low-profile quad flat package top view example . . . . .	122
Figure 40.	UFBGA132, 7 x 7 mm, 132-ball ultra thin, fine-pitch ball grid array package outline . . . . .	123
Figure 41.	UFBGA132, 7 x 7 mm, 132-ball ultra thin, fine-pitch ball grid array package recommended footprint. . . . .	124
Figure 42.	UFBGA132, 7 x 7 mm, 132-ball ultra thin, fine-pitch ball grid array package top view example . . . . .	125



Figure 43.	WLCSP104, 0.4 mm pitch wafer level chip scale package outline . . . . .	126
Figure 44.	WLCSP104, 0.4 mm pitch wafer level chip scale package recommended footprint. . . . .	127
Figure 45.	WLCSP104, 0.4 mm pitch wafer level chip scale package top view example . . . . .	128
Figure 46.	Thermal resistance suffix 6 . . . . .	130
Figure 47.	Thermal resistance suffix 7 . . . . .	130

# 1 Introduction

This datasheet provides the ordering information and mechanical device characteristics of the STM32L151xE and STM32L152xE ultra-low-power ARM<sup>®</sup> Cortex<sup>®</sup>-M3 based microcontroller product line. STM32L151xE and STM32L152xE devices are microcontrollers with a Flash memory density of 512 Kbytes.

The ultra-low-power STM32L151xE and STM32L152xE family includes devices in 5 different package types: from 64 pins to 144 pins. Depending on the device chosen, different sets of peripherals are included, the description below gives an overview of the complete range of peripherals proposed in this family.

These features make the ultra-low-power STM32L151xE and STM32L152xE microcontroller family suitable for a wide range of applications:

- Medical and handheld equipment
- Application control and user interface
- PC peripherals, gaming, GPS and sport equipment
- Alarm systems, wired and wireless sensors, video intercom
- Utility metering

This STM32L151xE and STM32L152xE datasheet should be read in conjunction with the STM32L1xxx reference manual (RM0038). The application note “Getting started with STM32L1xxx hardware development” (AN3216) gives a hardware implementation overview. Both documents are available from the STMicroelectronics website [www.st.com](http://www.st.com).

For information on the ARM<sup>®</sup> Cortex<sup>®</sup>-M3 core please refer to the ARM<sup>®</sup> Cortex<sup>®</sup>-M3 technical reference manual, available from the [www.arm.com](http://www.arm.com) website. *Figure 1* shows the general block diagram of the device family.

## 2 Description

The ultra-low-power STM32L151xE and STM32L152xE devices incorporate the connectivity power of the universal serial bus (USB) with the high-performance ARM<sup>®</sup> Cortex<sup>®</sup>-M3 32-bit RISC core operating at a frequency of 32 MHz (33.3 DMIPS), a memory protection unit (MPU), high-speed embedded memories (Flash memory up to 512 Kbytes and RAM up to 80 Kbytes), and an extensive range of enhanced I/Os and peripherals connected to two APB buses.

The STM32L151xE and STM32L152xE devices offer two operational amplifiers, one 12-bit ADC, two DACs, two ultra-low-power comparators, one general-purpose 32-bit timer, six general-purpose 16-bit timers and two basic timers, which can be used as time bases.

Moreover, the STM32L151xE and STM32L152xE devices contain standard and advanced communication interfaces: up to two I2Cs, three SPIs, two I2S, three USARTs, two UARTs and an USB. The STM32L151xE and STM32L152xE devices offer up to 34 capacitive sensing channels to simply add a touch sensing functionality to any application.

They also include a real-time clock and a set of backup registers that remain powered in Standby mode.

Finally, the integrated LCD controller (except STM32L151xE devices) has a built-in LCD voltage generator that allows to drive up to 8 multiplexed LCDs with the contrast independent of the supply voltage.

The ultra-low-power STM32L151xE and STM32L152xE devices operate from a 1.8 to 3.6 V power supply (down to 1.65 V at power down) with BOR and from a 1.65 to 3.6 V power supply without BOR option. They are available in the -40 to +85 °C and -40 to +105 °C temperature ranges. A comprehensive set of power-saving modes allows the design of low-power applications.



## 2.1 Device overview

Table 2. Ultra-low-power STM32L151xE and STM32L152xE device features and peripheral counts

Peripheral		STM32L15xRE	STM32L15xVE	STM32L15xQE	STM32L15xZE
Flash (Kbytes)		512			
Data EEPROM (Kbytes)		16			
RAM (Kbytes)		80			
Timers	32 bit	1			
	General-purpose	6			
	Basic	2			
Communication interfaces	SPI	8(3) <sup>(1)</sup>			
	I <sup>2</sup> S	2			
	I <sup>2</sup> C	2			
	USART	5			
	USB	1			
GPIOs		51	83	109	115
Operational amplifiers		2			
12-bit synchronized ADC Number of channels		1 21	1 25	1 40	1 40
12-bit DAC Number of channels		2 2			
LCD <sup>(2)</sup> COM x SEG		1 4x32 or 8x28	1 4x44 or 8x40		
Comparators		2			
Capacitive sensing channels		23		33	34
Max. CPU frequency		32 MHz			
Operating voltage		1.8 V to 3.6 V (down to 1.65 V at power-down) with BOR option 1.65 V to 3.6 V without BOR option			
Operating temperatures		Ambient operating temperature: -40 °C to 85 °C / -40 °C to 105 °C Junction temperature: -40 to + 110 °C			
Packages		LQFP64	LQFP100, WLCSP104	UFBGA132	LQFP144

1. 5 SPIs are USART configured in synchronous mode emulating SPI master.

2. STM32L152xx devices only.

## 2.2 Ultra-low-power device continuum

The ultra-low-power family offers a large choice of cores and features. From proprietary 8-bit to up to Cortex-M3, including the Cortex-M0+, the STM32Lx series are the best choice to answer the user needs, in terms of ultra-low-power features. The STM32 ultra-low-power series are the best fit, for instance, for gas/water meter, keyboard/mouse or fitness and healthcare, wearable applications. Several built-in features like LCD drivers, dual-bank memory, Low-power run mode, op-amp, AES 128-bit, DAC, USB crystal-less and many others will clearly allow to build very cost-optimized applications by reducing BOM.

*Note: STMicroelectronics as a reliable and long-term manufacturer ensures as much as possible the pin-to-pin compatibility between any STM8Lxxxx and STM32Lxxxx devices and between any of the STM32Lx and STM32Fx series. Thanks to this unprecedented scalability, the old applications can be upgraded to respond to the latest market features and efficiency demand.*

### 2.2.1 Performance

All families incorporate highly energy-efficient cores with both Harvard architecture and pipelined execution: advanced STM8 core for STM8L families and ARM Cortex-M3 core for STM32L family. In addition specific care for the design architecture has been taken to optimize the mA/DMIPS and mA/MHz ratios.

This allows the ultra-low-power performance to range from 5 up to 33.3 DMIPs.

### 2.2.2 Shared peripherals

STM8L15xxx, STM32L15xxx and STM32L162xx share identical peripherals which ensure a very easy migration from one family to another:

- Analog peripherals: ADC, DAC and comparators
- Digital peripherals: RTC and some communication interfaces

### 2.2.3 Common system strategy.

To offer flexibility and optimize performance, the STM8L15xxx, STM32L15xxx and STM32L162xx family uses a common architecture:

- Same power supply range from 1.65 V to 3.6 V
- Architecture optimized to reach ultra-low consumption both in low-power modes and Run mode
- Fast startup strategy from low-power modes
- Flexible system clock
- Ultrasafe reset: same reset strategy including power-on reset, power-down reset, brownout reset and programmable voltage detector

### 2.2.4 Features

ST ultra-low-power continuum also lies in feature compatibility:

- More than 15 packages with pin count from 20 to 144 pins and size down to 3 x 3 mm
- Memory density ranging from 2 to 512 Kbytes

### 3 Functional overview

Figure 1. Ultra-low-power STM32L151xE and STM32L152xE block diagram

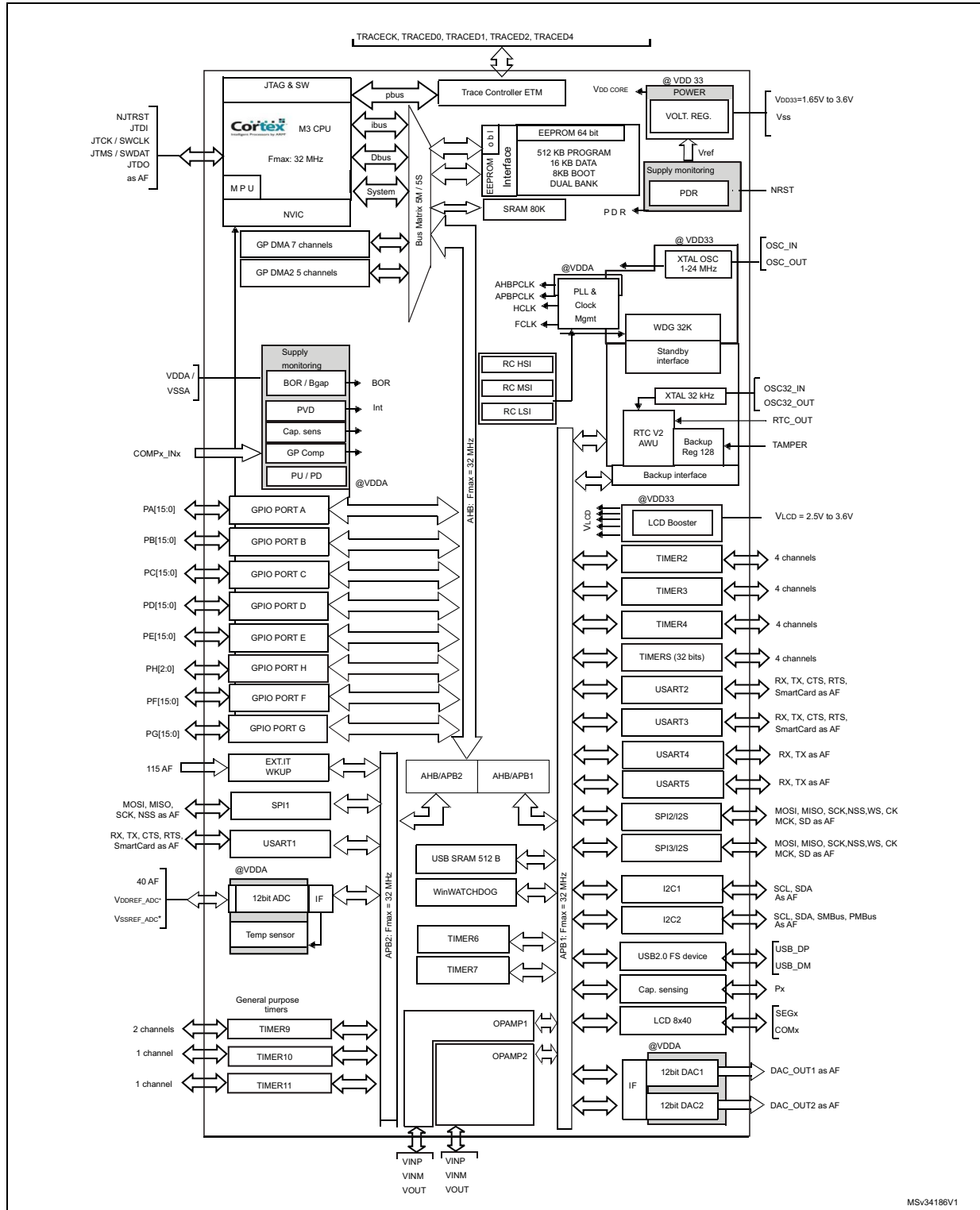

## 3.1 Low-power modes

The ultra-low-power STM32L151xE and STM32L152xE devices support dynamic voltage scaling to optimize its power consumption in run mode. The voltage from the internal low-drop regulator that supplies the logic can be adjusted according to the system's maximum operating frequency and the external voltage supply.

There are three power consumption ranges:

- Range 1 ( $V_{DD}$  range limited to 1.71 V - 3.6 V), with the CPU running at up to 32 MHz
- Range 2 (full  $V_{DD}$  range), with a maximum CPU frequency of 16 MHz
- Range 3 (full  $V_{DD}$  range), with a maximum CPU frequency limited to 4 MHz (generated only with the multispeed internal RC oscillator clock source)

Seven low-power modes are provided to achieve the best compromise between low-power consumption, short startup time and available wakeup sources:

- **Sleep mode**  
In Sleep mode, only the CPU is stopped. All peripherals continue to operate and can wake up the CPU when an interrupt/event occurs. Sleep mode power consumption at 16 MHz is about 1 mA with all peripherals off.
- **Low-power run mode**  
This mode is achieved with the multispeed internal (MSI) RC oscillator set to the minimum clock (131 kHz), execution from SRAM or Flash memory, and internal regulator in low-power mode to minimize the regulator's operating current. In low-power run mode, the clock frequency and the number of enabled peripherals are both limited.
- **Low-power sleep mode**  
This mode is achieved by entering Sleep mode with the internal voltage regulator in Low-power mode to minimize the regulator's operating current. In Low-power sleep mode, both the clock frequency and the number of enabled peripherals are limited; a typical example would be to have a timer running at 32 kHz.  
When wakeup is triggered by an event or an interrupt, the system reverts to the run mode with the regulator on.
- **Stop mode with RTC**  
Stop mode achieves the lowest power consumption while retaining the RAM and register contents and real time clock. All clocks in the  $V_{CORE}$  domain are stopped, the PLL, MSI RC, HSI RC and HSE crystal oscillators are disabled. The LSE or LSI is still running. The voltage regulator is in the low-power mode.  
The device can be woken up from Stop mode by any of the EXTI line, in 8  $\mu$ s. The EXTI line source can be one of the 16 external lines. It can be the PVD output, the Comparator 1 event or Comparator 2 event (if internal reference voltage is on), it can be the RTC alarm(s), the USB wakeup, the RTC tamper events, the RTC timestamp event or the RTC wakeup.

- Stop mode without RTC**

Stop mode achieves the lowest power consumption while retaining the RAM and register contents. All clocks are stopped, the PLL, MSI RC, HSI and LSI RC, LSE and HSE crystal oscillators are disabled. The voltage regulator is in the low-power mode. The device can be woken up from Stop mode by any of the EXTI line, in 8 μs. The EXTI line source can be one of the 16 external lines. It can be the PVD output, the Comparator 1 event or Comparator 2 event (if internal reference voltage is on). It can also be wakened by the USB wakeup.
- Standby mode with RTC**

Standby mode is used to achieve the lowest power consumption and real time clock. The internal voltage regulator is switched off so that the entire V<sub>CORE</sub> domain is powered off. The PLL, MSI RC, HSI RC and HSE crystal oscillators are also switched off. The LSE or LSI is still running. After entering Standby mode, the RAM and register contents are lost except for registers in the Standby circuitry (wakeup logic, IWDG, RTC, LSI, LSE Crystal 32K osc, RCC\_CSR).

The device exits Standby mode in 60 μs when an external reset (NRST pin), an IWDG reset, a rising edge on one of the three WKUP pins, RTC alarm (Alarm A or Alarm B), RTC tamper event, RTC timestamp event or RTC Wakeup event occurs.
- Standby mode without RTC**

Standby mode is used to achieve the lowest power consumption. The internal voltage regulator is switched off so that the entire V<sub>CORE</sub> domain is powered off. The PLL, MSI RC, HSI and LSI RC, HSE and LSE crystal oscillators are also switched off. After entering Standby mode, the RAM and register contents are lost except for registers in the Standby circuitry (wakeup logic, IWDG, RTC, LSI, LSE Crystal 32K osc, RCC\_CSR).

The device exits Standby mode in 60 μs when an external reset (NRST pin) or a rising edge on one of the three WKUP pin occurs.

*Note: The RTC, the IWDG, and the corresponding clock sources are not stopped automatically by entering Stop or Standby mode.*

**Table 3. Functionalities depending on the operating power supply range**

Operating power supply range	Functionalities depending on the operating power supply range			
	DAC and ADC operation	USB	Dynamic voltage scaling range	I/O operation
V <sub>DD</sub> =V <sub>DDA</sub> = 1.65 to 1.71 V	Not functional	Not functional	Range 2 or Range 3	Degraded speed performance
V <sub>DD</sub> =V <sub>DDA</sub> = 1.71 to 1.8 V <sup>(1)</sup>	Not functional	Not functional	Range 1, Range 2 or Range 3	Degraded speed performance
V <sub>DD</sub> =V <sub>DDA</sub> = 1.8 to 2.0 V <sup>(1)</sup>	Conversion time up to 500 Ksps	Not functional	Range 1, Range 2 or Range 3	Degraded speed performance



**Table 3. Functionalities depending on the operating power supply range (continued)**

Operating power supply range	Functionalities depending on the operating power supply range			
	DAC and ADC operation	USB	Dynamic voltage scaling range	I/O operation
$V_{DD}=V_{DDA} = 2.0 \text{ to } 2.4 \text{ V}$	Conversion time up to 500 Ksps	Functional <sup>(2)</sup>	Range 1, Range 2 or Range 3	Full speed operation
$V_{DD}=V_{DDA} = 2.4 \text{ to } 3.6 \text{ V}$	Conversion time up to 1 Msps	Functional <sup>(2)</sup>	Range 1, Range 2 or Range 3	Full speed operation

1. CPU frequency changes from initial to final must respect " $F_{CPU \text{ initial}} < 4 * F_{CPU \text{ final}}$ " to limit  $V_{CORE}$  drop due to current consumption peak when frequency increases. It must also respect 5  $\mu$ s delay between two changes. For example to switch from 4.2 MHz to 32 MHz, the user can switch from 4.2 MHz to 16 MHz, wait 5  $\mu$ s, then switch from 16 MHz to 32 MHz.
2. Should be USB compliant from I/O voltage standpoint, the minimum  $V_{DD}$  is 3.0 V.

**Table 4. CPU frequency range depending on dynamic voltage scaling**

CPU frequency range	Dynamic voltage scaling range
16 MHz to 32 MHz (1ws) 32 kHz to 16 MHz (0ws)	Range 1
8 MHz to 16 MHz (1ws) 32 kHz to 8 MHz (0ws)	Range 2
2.1MHz to 4.2 MHz (1ws) 32 kHz to 2.1 MHz (0ws)	Range 3

**Table 5. Functionalities depending on the working mode (from Run/active down to standby)**

Ips	Run/Active	Sleep	Low-power Run	Low-power Sleep	Stop		Standby	
					Wakeup capability	Wakeup capability		
CPU	Y	--	Y	--	--	--	--	--
Flash	Y	Y	Y	Y	--	--	--	--
RAM	Y	Y	Y	Y	Y	--	--	--
Backup Registers	Y	Y	Y	Y	Y	--	Y	--
EEPROM	Y	Y	Y	Y	Y	--	--	--
Brown-out rest (BOR)	Y	Y	Y	Y	Y	Y	Y	--
DMA	Y	Y	Y	Y	--	--	--	--
Programmable Voltage Detector (PVD)	Y	Y	Y	Y	Y	Y	Y	--
Power On Reset (POR)	Y	Y	Y	Y	Y	Y	Y	--
Power Down Rest (PDR)	Y	Y	Y	Y	Y	--	Y	--
High Speed Internal (HSI)	Y	Y	--	--	--	--	--	--
High Speed External (HSE)	Y	Y	--	--	--	--	--	--
Low Speed Internal (LSI)	Y	Y	Y	Y	Y	--	Y	--
Low Speed External (LSE)	Y	Y	Y	Y	Y	--	Y	--
Multi-Speed Internal (MSI)	Y	Y	Y	Y	--	--	--	--
Inter-Connect Controller	Y	Y	Y	Y	--	--	--	--
RTC	Y	Y	Y	Y	Y	Y	Y	--
RTC Tamper	Y	Y	Y	Y	Y	Y	Y	Y
Auto WakeUp (AWU)	Y	Y	Y	Y	Y	Y	Y	Y
LCD	Y	Y	Y	Y	Y	--	--	--
USB	Y	Y	--	--	--	Y	--	--
USART	Y	Y	Y	Y	Y	(1)	--	--
SPI	Y	Y	Y	Y	--	--	--	--
I2C	Y	Y	Y	Y	--	(1)	--	--

**Table 5. Functionalities depending on the working mode (from Run/active down to standby) (continued)**

Ips	Run/Active	Sleep	Low-power Run	Low-power Sleep	Stop		Standby	
					Wakeup capability	Wakeup capability		
ADC	Y	Y	--	--	--	--	--	--
DAC	Y	Y	Y	Y	Y	--	--	--
Tempsensor	Y	Y	Y	Y	Y	--	--	--
OP amp	Y	Y	Y	Y	Y	--	--	--
Comparators	Y	Y	Y	Y	Y	Y	--	--
16-bit and 32-bit Timers	Y	Y	Y	Y	--	--	--	--
IWDG	Y	Y	Y	Y	Y	Y	Y	Y
WWDG	Y	Y	Y	Y	--	--	--	--
Touch sensing	Y	Y	--	--	--	--	--	--
Systic Timer	Y	Y	Y	Y		--	--	--
GPIOs	Y	Y	Y	Y	Y	Y	--	3 pins
Wakeup time to Run mode	0 μs	0.4 μs	3 μs	46 μs	< 8 μs		58 μs	
Consumption V <sub>DD</sub> =1.8 to 3.6 V (Typ)	Down to 195 μA/MHz (from Flash)	Down to 38 μA/MHz (from Flash)	Down to 11 μA	Down to 4.6 μA	0.53 μA (no RTC) V <sub>DD</sub> =1.8V		0.285 μA (no RTC) V <sub>DD</sub> =1.8V	
					1.2 μA (with RTC) V <sub>DD</sub> =1.8V		0.97 μA (with RTC) V <sub>DD</sub> =1.8V	
					0.56 μA (no RTC) V <sub>DD</sub> =3.0V		0.29 μA (no RTC) V <sub>DD</sub> =3.0V	
					1.4 μA (with RTC) V <sub>DD</sub> =3.0V		1.11 μA (with RTC) V <sub>DD</sub> =3.0V	

1. The startup on communication line wakes the CPU which was made possible by an EXTI, this induces a delay before entering run mode.

### 3.2 ARM<sup>®</sup> Cortex<sup>®</sup>-M3 core with MPU

The ARM<sup>®</sup> Cortex<sup>®</sup>-M3 processor is the industry leading processor for embedded systems. It has been developed to provide a low-cost platform that meets the needs of MCU implementation, with a reduced pin count and low-power consumption, while delivering outstanding computational performance and an advanced system response to interrupts.

The ARM<sup>®</sup> Cortex<sup>®</sup>-M3 32-bit RISC processor features exceptional code-efficiency, delivering the high-performance expected from an ARM core in the memory size usually associated with 8- and 16-bit devices.



The memory protection unit (MPU) improves system reliability by defining the memory attributes (such as read/write access permissions) for different memory regions. It provides up to eight different regions and an optional predefined background region.

Owing to its embedded ARM core, the STM32L151xE and STM32L152xE devices are compatible with all ARM tools and software.

### **Nested vectored interrupt controller (NVIC)**

The ultra-low-power STM32L151xE and STM32L152xE devices embed a nested vectored interrupt controller able to handle up to 56 maskable interrupt channels (not including the 16 interrupt lines of ARM<sup>®</sup> Cortex<sup>®</sup>-M3) and 16 priority levels.

- Closely coupled NVIC gives low-latency interrupt processing
- Interrupt entry vector table address passed directly to the core
- Closely coupled NVIC core interface
- Allows early processing of interrupts
- Processing of *late arriving*, higher-priority interrupts
- Support for tail-chaining
- Processor state automatically saved
- Interrupt entry restored on interrupt exit with no instruction overhead

This hardware block provides flexible interrupt management features with minimal interrupt latency.

## **3.3 Reset and supply management**

### **3.3.1 Power supply schemes**

- $V_{DD} = 1.65$  to  $3.6$  V: external power supply for I/Os and the internal regulator. Provided externally through  $V_{DD}$  pins.
- $V_{SSA}$ ,  $V_{DDA} = 1.65$  to  $3.6$  V: external analog power supplies for ADC, reset blocks, RCs and PLL (minimum voltage to be applied to  $V_{DDA}$  is  $1.8$  V when the ADC is used).  $V_{DDA}$  and  $V_{SSA}$  must be connected to  $V_{DD}$  and  $V_{SS}$ , respectively.

### **3.3.2 Power supply supervisor**

The device has an integrated ZEROPOWER power-on reset (POR)/power-down reset (PDR) that can be coupled with a brownout reset (BOR) circuitry.

The device exists in two versions:

- The version with BOR activated at power-on operates between  $1.8$  V and  $3.6$  V.
- The other version without BOR operates between  $1.65$  V and  $3.6$  V.

After the  $V_{DD}$  threshold is reached ( $1.65$  V or  $1.8$  V depending on the BOR which is active or not at power-on), the option byte loading process starts, either to confirm or modify default thresholds, or to disable the BOR permanently: in this case, the  $V_{DD}$  min value becomes  $1.65$  V (whatever the version, BOR active or not, at power-on).

When BOR is active at power-on, it ensures proper operation starting from  $1.8$  V whatever the power ramp-up phase before it reaches  $1.8$  V. When BOR is not active at power-up, the

power ramp-up should guarantee that 1.65 V is reached on  $V_{DD}$  at least 1 ms after it exits the POR area.

Five BOR thresholds are available through option bytes, starting from 1.8 V to 3 V. To reduce the power consumption in Stop mode, it is possible to automatically switch off the internal reference voltage ( $V_{REFINT}$ ) in Stop mode. The device remains in reset mode when  $V_{DD}$  is below a specified threshold,  $V_{POR/PDR}$  or  $V_{BOR}$ , without the need for any external reset circuit.

*Note: The start-up time at power-on is typically 3.3 ms when BOR is active at power-up, the start-up time at power-on can be decreased down to 1 ms typically for devices with BOR inactive at power-up.*

The device features an embedded programmable voltage detector (PVD) that monitors the  $V_{DD}/V_{DDA}$  power supply and compares it to the  $V_{PVD}$  threshold. This PVD offers 7 different levels between 1.85 V and 3.05 V, chosen by software, with a step around 200 mV. An interrupt can be generated when  $V_{DD}/V_{DDA}$  drops below the  $V_{PVD}$  threshold and/or when  $V_{DD}/V_{DDA}$  is higher than the  $V_{PVD}$  threshold. The interrupt service routine can then generate a warning message and/or put the MCU into a safe state. The PVD is enabled by software.

### 3.3.3 Voltage regulator

The regulator has three operation modes: main (MR), low-power (LPR) and power down.

- MR is used in Run mode (nominal regulation)
- LPR is used in the Low-power run, Low-power sleep and Stop modes
- Power down is used in Standby mode. The regulator output is high impedance, the kernel circuitry is powered down, inducing zero consumption but the contents of the registers and RAM are lost except for the standby circuitry (wake-up logic, IWDG, RTC, LSI, LSE crystal 32K osc, RCC\_CSR).

### 3.3.4 Boot modes

At startup, boot pins are used to select one of three boot options:

- Boot from Flash memory
- Boot from System memory
- Boot from embedded RAM

The boot from Flash usually boots at the beginning of the Flash (bank 1). An additional boot mechanism is available through user option byte, to allow booting from bank 2 when bank 2 contains valid code. This dual boot capability can be used to easily implement a secure field software update mechanism.

The boot loader is located in System memory. It is used to reprogram the Flash memory by using USART1, USART2 or USB. See Application note "STM32 microcontroller system memory boot mode" (AN2606) for details.

## 3.4 Clock management

The clock controller distributes the clocks coming from different oscillators to the core and the peripherals. It also manages clock gating for low-power modes and ensures clock robustness. It features:

- **Clock prescaler:** to get the best trade-off between speed and current consumption, the clock frequency to the CPU and peripherals can be adjusted by a programmable prescaler.
- **Safe clock switching:** clock sources can be changed safely on the fly in run mode through a configuration register.
- **Clock management:** to reduce power consumption, the clock controller can stop the clock to the core, individual peripherals or memory.
- **System clock source:** three different clock sources can be used to drive the master clock SYSCLK:
  - 1-24 MHz high-speed external crystal (HSE), that can supply a PLL
  - 16 MHz high-speed internal RC oscillator (HSI), trimmable by software, that can supply a PLL
  - Multispeed internal RC oscillator (MSI), trimmable by software, able to generate 7 frequencies (65 kHz, 131 kHz, 262 kHz, 524 kHz, 1.05 MHz, 2.1 MHz, 4.2 MHz). When a 32.768 kHz clock source is available in the system (LSE), the MSI frequency can be trimmed by software down to a  $\pm 0.5\%$  accuracy.
- **Auxiliary clock source:** two ultra-low-power clock sources that can be used to drive the LCD controller and the real-time clock:
  - 32.768 kHz low-speed external crystal (LSE)
  - 37 kHz low-speed internal RC (LSI), also used to drive the independent watchdog. The LSI clock can be measured using the high-speed internal RC oscillator for greater precision.
- **RTC and LCD clock sources:** the LSI, LSE or HSE sources can be chosen to clock the RTC and the LCD, whatever the system clock.
- **USB clock source:** the embedded PLL has a dedicated 48 MHz clock output to supply the USB interface.
- **Startup clock:** after reset, the microcontroller restarts by default with an internal 2 MHz clock (MSI). The prescaler ratio and clock source can be changed by the application program as soon as the code execution starts.
- **Clock security system (CSS):** this feature can be enabled by software. If a HSE clock failure occurs, the master clock is automatically switched to HSI and a software interrupt is generated if enabled.
- **Clock-out capability (MCO: microcontroller clock output):** it outputs one of the internal clocks for external use by the application.

Several prescalers allow the configuration of the AHB frequency, each APB (APB1 and APB2) domains. The maximum frequency of the AHB and the APB domains is 32 MHz. See [Figure 2](#) for details on the clock tree.

Figure 2. Clock tree

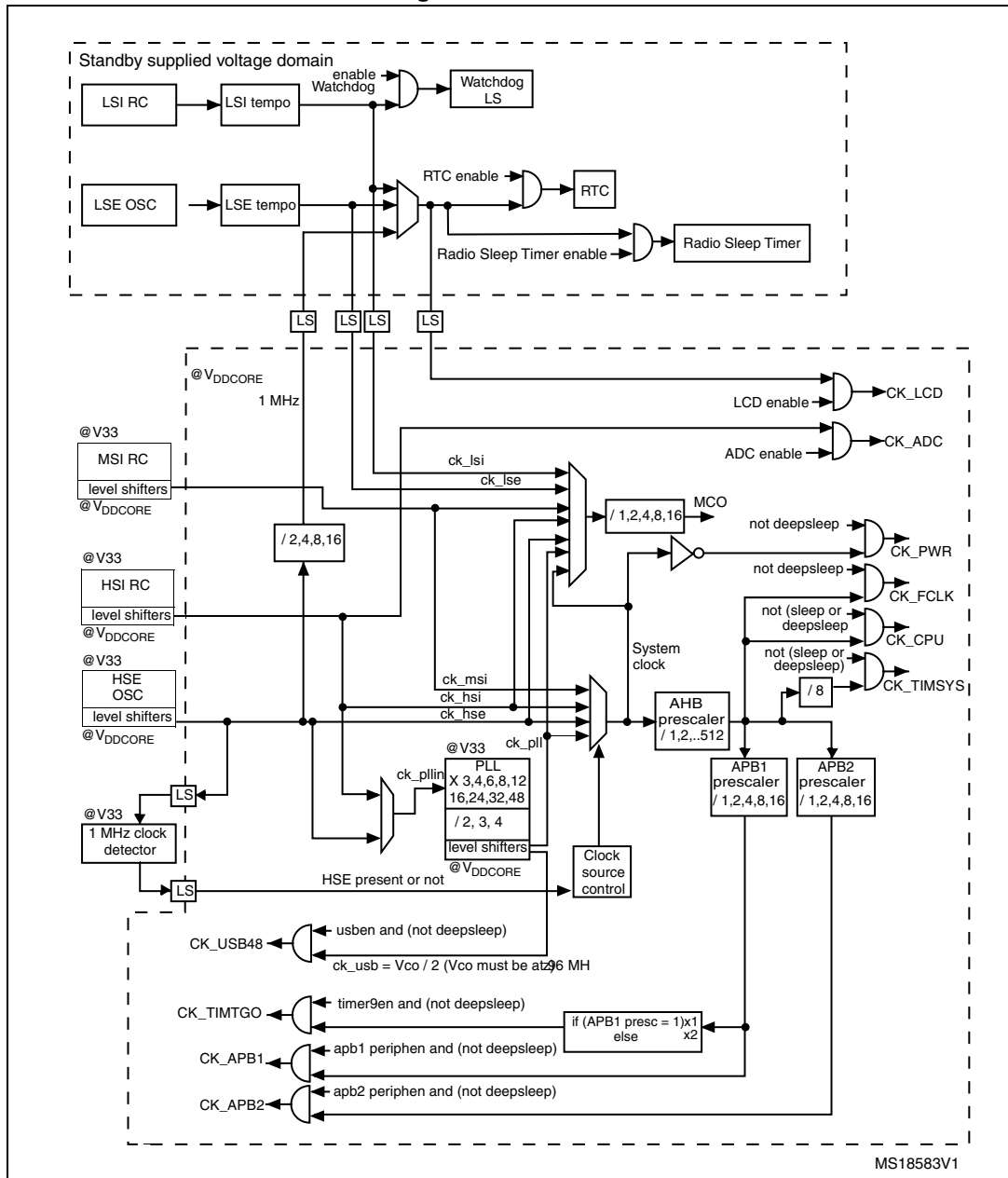

1. For the USB function to be available, both HSE and PLL must be enabled, with the CPU running at either 24 MHz or 32 MHz.

### 3.5 Low-power real-time clock and backup registers

The real-time clock (RTC) is an independent BCD timer/counter. Dedicated registers contain the sub-second, second, minute, hour (12/24 hour), week day, date, month, year, in BCD (binary-coded decimal) format. Correction for 28, 29 (leap year), 30, and 31 day of the month are made automatically. The RTC provides two programmable alarms and programmable periodic interrupts with wakeup from Stop and Standby modes.

The programmable wakeup time ranges from 120  $\mu$ s to 36 hours.

The RTC can be calibrated with an external 512 Hz output, and a digital compensation circuit helps reduce drift due to crystal deviation.

The RTC can also be automatically corrected with a 50/60Hz stable powerline.

The RTC calendar can be updated on the fly down to sub second precision, which enables network system synchronization.

A time stamp can record an external event occurrence, and generates an interrupt.

There are thirty-two 32-bit backup registers provided to store 128 bytes of user application data. They are cleared in case of tamper detection.

Three pins can be used to detect tamper events. A change on one of these pins can reset backup register and generate an interrupt. To prevent false tamper event, like ESD event, these three tamper inputs can be digitally filtered.

### 3.6 GPIOs (general-purpose inputs/outputs)

Each of the GPIO pins can be configured by software as output (push-pull or open-drain), as input (with or without pull-up or pull-down) or as peripheral alternate function. Most of the GPIO pins are shared with digital or analog alternate functions, and can be individually remapped using dedicated AFIO registers. All GPIOs are high current capable. The alternate function configuration of I/Os can be locked if needed following a specific sequence in order to avoid spurious writing to the I/O registers. The I/O controller is connected to the AHB with a toggling speed of up to 16 MHz.

#### External interrupt/event controller (EXTI)

The external interrupt/event controller consists of 24 edge detector lines used to generate interrupt/event requests. Each line can be individually configured to select the trigger event (rising edge, falling edge, both) and can be masked independently. A pending register maintains the status of the interrupt requests. The EXTI can detect an external line with a pulse width shorter than the Internal APB2 clock period. Up to 115 GPIOs can be connected to the 16 external interrupt lines. The 8 other lines are connected to RTC, PVD, USB, comparator events or capacitive sensing acquisition.



## 3.7 Memories

The STM32L151xE and STM32L152xE devices have the following features:

- 80 Kbytes of embedded RAM accessed (read/write) at CPU clock speed with 0 wait states. With the enhanced bus matrix, operating the RAM does not lead to any performance penalty during accesses to the system bus (AHB and APB buses).
- The non-volatile memory is divided into three arrays:
  - 512 Kbytes of embedded Flash program memory
  - 16 Kbytes of data EEPROM
  - Options bytes

Flash program and data EEPROM are divided into two banks, this enables writing in one bank while running code or reading data in the other bank.

The options bytes are used to write-protect or read-out protect the memory (with 4 Kbytes granularity) and/or readout-protect the whole memory with the following options:

- Level 0: no readout protection
- Level 1: memory readout protection, the Flash memory cannot be read from or written to if either debug features are connected or boot in RAM is selected
- Level 2: chip readout protection, debug features (ARM Cortex-M3 JTAG and serial wire) and boot in RAM selection disabled (JTAG fuse)

The whole non-volatile memory embeds the error correction code (ECC) feature.

## 3.8 DMA (direct memory access)

The flexible 12-channel, general-purpose DMA is able to manage memory-to-memory, peripheral-to-memory and memory-to-peripheral transfers. The DMA controller supports circular buffer management, avoiding the generation of interrupts when the controller reaches the end of the buffer.

Each channel is connected to dedicated hardware DMA requests, with software trigger support for each channel. Configuration is done by software and transfer sizes between source and destination are independent.

The DMA can be used with the main peripherals: SPI, I<sup>2</sup>C, USART, general-purpose timers, DAC and ADC.

## 3.9 LCD (liquid crystal display)

The LCD drives up to 8 common terminals and 44 segment terminals to drive up to 320 pixels.

- Internal step-up converter to guarantee functionality and contrast control irrespective of  $V_{DD}$ . This converter can be deactivated, in which case the  $V_{LCD}$  pin is used to provide the voltage to the LCD
- Supports static, 1/2, 1/3, 1/4 and 1/8 duty
- Supports static, 1/2, 1/3 and 1/4 bias
- Phase inversion to reduce power consumption and EMI
- Up to 8 pixels can be programmed to blink
- Unneeded segments and common pins can be used as general I/O pins
- LCD RAM can be updated at any time owing to a double-buffer
- The LCD controller can operate in Stop mode

## 3.10 ADC (analog-to-digital converter)

A 12-bit analog-to-digital converters is embedded into STM32L151xE and STM32L152xE devices with up to 40 external channels, performing conversions in single-shot or scan mode. In scan mode, automatic conversion is performed on a selected group of analog inputs with up to 28 external channels in a group.

The ADC can be served by the DMA controller.

An analog watchdog feature allows very precise monitoring of the converted voltage of one, some or all scanned channels. An interrupt is generated when the converted voltage is outside the programmed thresholds.

The events generated by the general-purpose timers (TIMx) can be internally connected to the ADC start triggers, to allow the application to synchronize A/D conversions and timers. An injection mode allows high priority conversions to be done by interrupting a scan mode which runs in as a background task.

The ADC includes a specific low-power mode. The converter is able to operate at maximum speed even if the CPU is operating at a very low frequency and has an auto-shutdown function. The ADC's runtime and analog front-end current consumption are thus minimized whatever the MCU operating mode.

### 3.10.1 Temperature sensor

The temperature sensor (TS) generates a voltage  $V_{SENSE}$  that varies linearly with temperature.

The temperature sensor is internally connected to the ADC\_IN16 input channel which is used to convert the sensor output voltage into a digital value.

The sensor provides good linearity but it has to be calibrated to obtain good overall accuracy of the temperature measurement. As the offset of the temperature sensor varies from chip to chip due to process variation, the uncalibrated internal temperature sensor is suitable for applications that detect temperature changes only.

To improve the accuracy of the temperature sensor measurement, each device is individually factory-calibrated by ST. The temperature sensor factory calibration data are