



Chipsmall Limited consists of a professional team with an average of over 10 year of expertise in the distribution of electronic components. Based in Hongkong, we have already established firm and mutual-benefit business relationships with customers from,Europe,America and south Asia,supplying obsolete and hard-to-find components to meet their specific needs.

With the principle of "Quality Parts,Customers Priority,Honest Operation,and Considerate Service",our business mainly focus on the distribution of electronic components. Line cards we deal with include Microchip,ALPS,ROHM,Xilinx,Pulse,ON,Everlight and Freescale. Main products comprise IC,Modules,Potentiometer,IC Socket,Relay,Connector.Our parts cover such applications as commercial,industrial, and automotives areas.

We are looking forward to setting up business relationship with you and hope to provide you with the best service and solution. Let us make a better world for our industry!



Contact us

Tel: +86-755-8981 8866 Fax: +86-755-8427 6832

Email & Skype: info@chipsmall.com Web: www.chipsmall.com

Address: A1208, Overseas Decoration Building, #122 Zhenhua RD., Futian, Shenzhen, China



Ultra-low-power ARM[®] Cortex[®]-M4 32-bit MCU+FPU, 100DMIPS, up to 1MB Flash, 128 KB SRAM, USB OTG FS, analog, audio

Datasheet - production data

Features

- Ultra-low-power with FlexPowerControl
 - 1.71 V to 3.6 V power supply
 - -40 °C to 85/105/125 °C temperature range
 - 300 nA in V_{BAT} mode: supply for RTC and 32x32-bit backup registers
 - 30 nA Shutdown mode (5 wakeup pins)
 - 120 nA Standby mode (5 wakeup pins)
 - 420 nA Standby mode with RTC
 - 1.1 µA Stop 2 mode, 1.4 µA Stop 2 with RTC
 - 100 µA/MHz run mode
 - Batch acquisition mode (BAM)
 - 4 µs wakeup from Stop mode
 - Brown out reset (BOR) in all modes except shutdown
 - Interconnect matrix
- Core: ARM[®] 32-bit Cortex[®]-M4 CPU with FPU, Adaptive real-time accelerator (ART Accelerator™) allowing 0-wait-state execution from Flash memory, frequency up to 80 MHz, MPU, 100DMIPS/1.25DMIPS/MHz (Dhystone 2.1), and DSP instructions
- Clock Sources
 - 4 to 48 MHz crystal oscillator
 - 32 kHz crystal oscillator for RTC (LSE)
 - Internal 16 MHz factory-trimmed RC (±1%)
 - Internal low-power 32 kHz RC (±5%)
 - Internal multispeed 100 kHz to 48 MHz oscillator, auto-trimmed by LSE (better than ±0.25 % accuracy)
 - 3 PLLs for system clock, USB, audio, ADC
- RTC with HW calendar, alarms and calibration
- Up to 21 capacitive sensing channels: support touchkey, linear and rotary touch sensors
- 16x timers: 2 x 16-bit advanced motor-control, 2 x 32-bit and 5 x 16-bit general purpose, 2x 16-bit basic, 2x low-power 16-bit timers (available in Stop mode), 2x watchdogs, SysTick timer
- Up to 114 fast I/Os, most 5 V-tolerant, up to 14 I/Os with independent supply down to 1.08 V

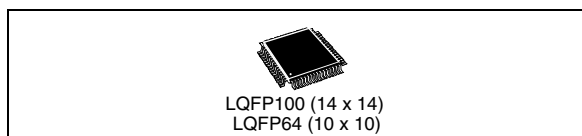

- Memories
 - Up to 1 MB Flash, 2 banks read-while-write, proprietary code readout protection
 - Up to 128 KB of SRAM including 32 KB with hardware parity check
 - External memory interface for static memories supporting SRAM, PSRAM and NOR memories
 - Quad SPI memory interface
- 4x digital filters for sigma delta modulator
- Rich analog peripherals (independent supply)
 - 3x 12-bit ADC 5 Msps, up to 16-bit with hardware oversampling, 200 µA/Msps
 - 2x 12-bit DAC, low-power sample and hold
 - 2x operational amplifiers with built-in PGA
 - 2x ultra-low-power comparators
- 18x communication interfaces
 - USB OTG 2.0 full-speed, LPM and BCD
 - 2x SAs (serial audio interface)
 - 3x I2C FM+(1 Mbit/s), SMBus/PMBus
 - 6x USARTs (ISO 7816, LIN, IrDA, modem)
 - 3x SPIs (4x SPIs with the Quad SPI)
 - CAN (2.0B Active) and SDMMC interface
 - SWPMI single wire protocol master I/F
- 14-channel DMA controller
- True random number generator
- CRC calculation unit, 96-bit unique ID
- Development support: serial wire debug (SWD), JTAG, Embedded Trace Macrocell™

Table 1. Device summary

Reference	Part number
STM32L475xx	STM32L475RG, STM32L475VG, STM32L475RE, STM32L475VE, STM32L475RC, STM32L475VC

Contents

- 1 Introduction 10**
- 2 Description 11**
- 3 Functional overview 15**
 - 3.1 ARM® Cortex®-M4 core with FPU 15
 - 3.2 Adaptive real-time memory accelerator (ART Accelerator™) 15
 - 3.3 Memory protection unit 15
 - 3.4 Embedded Flash memory 16
 - 3.5 Embedded SRAM 17
 - 3.6 Firewall 17
 - 3.7 Boot modes 18
 - 3.8 Cyclic redundancy check calculation unit (CRC) 18
 - 3.9 Power supply management 18
 - 3.9.1 Power supply schemes 18
 - 3.9.2 Power supply supervisor 19
 - 3.9.3 Voltage regulator 20
 - 3.9.4 Low-power modes 20
 - 3.9.5 Reset mode 28
 - 3.9.6 VBAT operation 28
 - 3.10 Interconnect matrix 29
 - 3.11 Clocks and startup 31
 - 3.12 General-purpose inputs/outputs (GPIOs) 34
 - 3.13 Direct memory access controller (DMA) 34
 - 3.14 Interrupts and events 35
 - 3.14.1 Nested vectored interrupt controller (NVIC) 35
 - 3.14.2 Extended interrupt/event controller (EXTI) 35
 - 3.15 Analog to digital converter (ADC) 36
 - 3.15.1 Temperature sensor 36
 - 3.15.2 Internal voltage reference (VREFINT) 37
 - 3.15.3 VBAT battery voltage monitoring 37
 - 3.16 Digital to analog converter (DAC) 37

3.17	Voltage reference buffer (VREFBUF)	38
3.18	Comparators (COMP)	38
3.19	Operational amplifier (OPAMP)	39
3.20	Touch sensing controller (TSC)	39
3.21	Digital filter for Sigma-Delta Modulators (DFSDM)	40
3.22	Random number generator (RNG)	41
3.23	Timers and watchdogs	41
3.23.1	Advanced-control timer (TIM1, TIM8)	42
3.23.2	General-purpose timers (TIM2, TIM3, TIM4, TIM5, TIM15, TIM16, TIM17)	42
3.23.3	Basic timers (TIM6 and TIM7)	43
3.23.4	Low-power timer (LPTIM1 and LPTIM2)	43
3.23.5	Independent watchdog (IWDG)	43
3.23.6	System window watchdog (WWDG)	43
3.23.7	SysTick timer	44
3.24	Real-time clock (RTC) and backup registers	44
3.25	Inter-integrated circuit interface (I ² C)	45
3.26	Universal synchronous/asynchronous receiver transmitter (USART)	46
3.27	Low-power universal asynchronous receiver transmitter (LPUART)	47
3.28	Serial peripheral interface (SPI)	48
3.29	Serial audio interfaces (SAI)	48
3.30	Single wire protocol master interface (SWPMI)	49
3.31	Controller area network (CAN)	49
3.32	Secure digital input/output and MultiMediaCards Interface (SDMMC)	50
3.33	Universal serial bus on-the-go full-speed (OTG_FS)	50
3.34	Flexible static memory controller (FSMC)	51
3.35	Quad SPI memory interface (QUADSPI)	51
3.36	Development support	53
3.36.1	Serial wire JTAG debug port (SWJ-DP)	53
3.36.2	Embedded Trace Macrocell™	53
4	Pinouts and pin description	54
5	Memory mapping	75

6 Electrical characteristics 80

- 6.1 Parameter conditions 80
 - 6.1.1 Minimum and maximum values 80
 - 6.1.2 Typical values 80
 - 6.1.3 Typical curves 80
 - 6.1.4 Loading capacitor 80
 - 6.1.5 Pin input voltage 80
 - 6.1.6 Power supply scheme 81
 - 6.1.7 Current consumption measurement 82
- 6.2 Absolute maximum ratings 82
- 6.3 Operating conditions 84
 - 6.3.1 General operating conditions 84
 - 6.3.2 Operating conditions at power-up / power-down 85
 - 6.3.3 Embedded reset and power control block characteristics 85
 - 6.3.4 Embedded voltage reference 87
 - 6.3.5 Supply current characteristics 89
 - 6.3.6 Wakeup time from low-power modes and voltage scaling transition times 108
 - 6.3.7 External clock source characteristics 110
 - 6.3.8 Internal clock source characteristics 115
 - 6.3.9 PLL characteristics 120
 - 6.3.10 Flash memory characteristics 122
 - 6.3.11 EMC characteristics 123
 - 6.3.12 Electrical sensitivity characteristics 124
 - 6.3.13 I/O current injection characteristics 125
 - 6.3.14 I/O port characteristics 126
 - 6.3.15 NRST pin characteristics 132
 - 6.3.16 Analog switches booster 133
 - 6.3.17 Analog-to-Digital converter characteristics 134
 - 6.3.18 Digital-to-Analog converter characteristics 147
 - 6.3.19 Voltage reference buffer characteristics 151
 - 6.3.20 Comparator characteristics 153
 - 6.3.21 Operational amplifiers characteristics 154
 - 6.3.22 Temperature sensor characteristics 157
 - 6.3.23 V_{BAT} monitoring characteristics 157
 - 6.3.24 DFSDM characteristics 158
 - 6.3.25 Timer characteristics 159

6.3.26	Communication interfaces characteristics	161
6.3.27	FSMC characteristics	173
7	Package information	182
7.1	LQFP100 package information	182
7.2	LQFP64 package information	185
7.3	Thermal characteristics	188
7.3.1	Reference document	188
7.3.2	Selecting the product temperature range	188
8	Part numbering	191
9	Revision history	192

List of tables

Table 1.	Device summary	1
Table 2.	STM32L475xx family device features and peripheral counts	12
Table 3.	Access status versus readout protection level and execution modes.	16
Table 4.	STM32L475 modes overview	21
Table 5.	Functionalities depending on the working mode.	26
Table 6.	STM32L475xx peripherals interconnect matrix	29
Table 7.	DMA implementation	34
Table 8.	Temperature sensor calibration values.	37
Table 9.	Internal voltage reference calibration values	37
Table 10.	Timer feature comparison.	41
Table 11.	I2C implementation.	45
Table 12.	STM32L475xx USART/UART/LPUART features	46
Table 13.	SAI implementation.	49
Table 14.	Legend/abbreviations used in the pinout table	55
Table 15.	STM32L475xx pin definitions	55
Table 16.	Alternate function AF0 to AF7 (for AF8 to AF15 see Table 17)	65
Table 17.	Alternate function AF8 to AF15 (for AF0 to AF7 see Table 16)	70
Table 18.	STM32L475xx memory map and peripheral register boundary addresses	76
Table 19.	Voltage characteristics	82
Table 20.	Current characteristics	83
Table 21.	Thermal characteristics.	83
Table 22.	General operating conditions	84
Table 23.	Operating conditions at power-up / power-down	85
Table 24.	Embedded reset and power control block characteristics.	85
Table 25.	Embedded internal voltage reference.	87
Table 26.	Current consumption in Run and Low-power run modes, code with data processing running from Flash, ART enable (Cache ON Prefetch OFF)	90
Table 27.	Current consumption in Run and Low-power run modes, code with data processing running from Flash, ART disable	91
Table 28.	Current consumption in Run and Low-power run modes, code with data processing running from SRAM1	92
Table 29.	Typical current consumption in Run and Low-power run modes, with different codes running from Flash, ART enable (Cache ON Prefetch OFF)	93
Table 30.	Typical current consumption in Run and Low-power run modes, with different codes running from Flash, ART disable	94
Table 31.	Typical current consumption in Run and Low-power run modes, with different codes running from SRAM1	94
Table 32.	Current consumption in Sleep and Low-power sleep modes, Flash ON	95
Table 33.	Current consumption in Low-power sleep modes, Flash in power-down	96
Table 34.	Current consumption in Stop 2 mode	96
Table 35.	Current consumption in Stop 1 mode	98
Table 36.	Current consumption in Stop 0 mode	99
Table 37.	Current consumption in Standby mode	100
Table 38.	Current consumption in Shutdown mode	101
Table 39.	Current consumption in VBAT mode	103
Table 40.	Peripheral current consumption	105
Table 41.	Low-power mode wakeup timings	108

Table 42.	Regulator modes transition times	110
Table 43.	Wakeup time using USART/LPUART	110
Table 44.	High-speed external user clock characteristics	110
Table 45.	Low-speed external user clock characteristics	111
Table 46.	HSE oscillator characteristics	112
Table 47.	LSE oscillator characteristics ($f_{LSE} = 32.768$ kHz)	113
Table 48.	HSI16 oscillator characteristics	115
Table 49.	MSI oscillator characteristics	117
Table 50.	LSI oscillator characteristics	120
Table 51.	PLL, PLLSAI1, PLLSAI2 characteristics	121
Table 52.	Flash memory characteristics	122
Table 53.	Flash memory endurance and data retention	122
Table 54.	EMS characteristics	123
Table 55.	EMI characteristics	124
Table 56.	ESD absolute maximum ratings	124
Table 57.	Electrical sensitivities	125
Table 58.	I/O current injection susceptibility	125
Table 59.	I/O static characteristics	126
Table 60.	Output voltage characteristics	129
Table 61.	I/O AC characteristics	130
Table 62.	NRST pin characteristics	132
Table 63.	Analog switches booster characteristics	133
Table 64.	ADC characteristics	134
Table 65.	Maximum ADC RAIN	136
Table 66.	ADC accuracy - limited test conditions 1	138
Table 67.	ADC accuracy - limited test conditions 2	140
Table 68.	ADC accuracy - limited test conditions 3	142
Table 69.	ADC accuracy - limited test conditions 4	144
Table 70.	DAC characteristics	147
Table 71.	DAC accuracy	149
Table 72.	VREFBUF characteristics	151
Table 73.	COMP characteristics	153
Table 74.	OPAMP characteristics	154
Table 75.	TS characteristics	157
Table 76.	V_{BAT} monitoring characteristics	157
Table 77.	V_{BAT} charging characteristics	157
Table 78.	DFSDM characteristics	158
Table 79.	TIMx characteristics	160
Table 80.	IWDG min/max timeout period at 32 kHz (LSI)	160
Table 81.	WWDG min/max timeout value at 80 MHz (PCLK)	160
Table 82.	I2C analog filter characteristics	161
Table 83.	SPI characteristics	162
Table 84.	Quad SPI characteristics in SDR mode	165
Table 85.	QUADSPI characteristics in DDR mode	166
Table 86.	SAI characteristics	167
Table 87.	SD / MMC dynamic characteristics, $V_{DD} = 2.7$ V to 3.6 V	169
Table 88.	eMMC dynamic characteristics, $V_{DD} = 1.71$ V to 1.9 V	170
Table 89.	USB electrical characteristics	172
Table 90.	Asynchronous multiplexed PSRAM/NOR read timings	175
Table 91.	Asynchronous multiplexed PSRAM/NOR read-NWAIT timings	175
Table 92.	Asynchronous multiplexed PSRAM/NOR write timings	177
Table 93.	Asynchronous multiplexed PSRAM/NOR write-NWAIT timings	177

Table 94.	Synchronous multiplexed NOR/PSRAM read timings	179
Table 95.	Synchronous multiplexed PSRAM write timings	181
Table 96.	LQPF100 - 100-pin, 14 x 14 mm low-profile quad flat package mechanical data	183
Table 97.	LQFP64 - 64-pin, 10 x 10 mm low-profile quad flat package mechanical data	185
Table 98.	Package thermal characteristics	188
Table 99.	STM32L475xx ordering information scheme	191
Table 100.	Document revision history	192

List of figures

Figure 1.	STM32L475xx block diagram	14
Figure 2.	Power supply overview	19
Figure 3.	Clock tree	33
Figure 4.	Voltage reference buffer	38
Figure 5.	STM32L475Vx LQFP100 pinout ⁽¹⁾	54
Figure 6.	STM32L475Rx LQFP64 pinout ⁽¹⁾	54
Figure 7.	STM32L475 memory map	75
Figure 8.	Pin loading conditions	80
Figure 9.	Pin input voltage	80
Figure 10.	Power supply scheme	81
Figure 11.	Current consumption measurement scheme	82
Figure 12.	VREFINT versus temperature	88
Figure 13.	High-speed external clock source AC timing diagram	111
Figure 14.	Low-speed external clock source AC timing diagram	111
Figure 15.	Typical application with an 8 MHz crystal	113
Figure 16.	Typical application with a 32.768 kHz crystal	114
Figure 17.	HSI16 frequency versus temperature	116
Figure 18.	Typical current consumption versus MSI frequency	120
Figure 19.	I/O input characteristics	128
Figure 20.	I/O AC characteristics definition ⁽¹⁾	132
Figure 21.	Recommended NRST pin protection	133
Figure 22.	ADC accuracy characteristics	146
Figure 23.	Typical connection diagram using the ADC	146
Figure 24.	12-bit buffered / non-buffered DAC	149
Figure 25.	SPI timing diagram - slave mode and CPHA = 0	163
Figure 26.	SPI timing diagram - slave mode and CPHA = 1	164
Figure 27.	SPI timing diagram - master mode	164
Figure 28.	Quad SPI timing diagram - SDR mode	166
Figure 29.	Quad SPI timing diagram - DDR mode	166
Figure 30.	SAI master timing waveforms	168
Figure 31.	SAI slave timing waveforms	169
Figure 32.	SDIO high-speed mode	170
Figure 33.	SD default mode	171
Figure 34.	Asynchronous multiplexed PSRAM/NOR read waveforms	174
Figure 35.	Asynchronous multiplexed PSRAM/NOR write waveforms	176
Figure 36.	Synchronous multiplexed NOR/PSRAM read timings	178
Figure 37.	Synchronous multiplexed PSRAM write timings	180
Figure 38.	LQFP100 - 100-pin, 14 x 14 mm low-profile quad flat package outline	182
Figure 39.	LQFP100 - 100-pin, 14 x 14 mm low-profile quad flat recommended footprint	184
Figure 40.	LQFP100 marking (package top view)	184
Figure 41.	LQFP64 - 64-pin, 10 x 10 mm low-profile quad flat package outline	185
Figure 42.	LQFP64 - 64-pin, 10 x 10 mm low-profile quad flat package recommended footprint	186
Figure 43.	LQFP64 marking (package top view)	187
Figure 44.	LQFP64 P _D max vs. T _A	190

1 Introduction

This datasheet provides the ordering information and mechanical device characteristics of the STM32L475xx microcontrollers.

This document should be read in conjunction with the STM32L4x5 reference manual (RM0395). The reference manual is available from the STMicroelectronics website www.st.com.

For information on the ARM® Cortex®-M4 core, please refer to the Cortex®-M4 Technical Reference Manual, available from the www.arm.com website.



2 Description

The STM32L475xx devices are the ultra-low-power microcontrollers based on the high-performance ARM[®] Cortex[®]-M4 32-bit RISC core operating at a frequency of up to 80 MHz. The Cortex-M4 core features a Floating point unit (FPU) single precision which supports all ARM single-precision data-processing instructions and data types. It also implements a full set of DSP instructions and a memory protection unit (MPU) which enhances application security.

The STM32L475xx devices embed high-speed memories (Flash memory up to 1 Mbyte, up to 128 Kbyte of SRAM), a flexible external memory controller (FSMC) for static memories (for devices with 100 pins package), a Quad SPI flash memories interface (available on all packages) and an extensive range of enhanced I/Os and peripherals connected to two APB buses, two AHB buses and a 32-bit multi-AHB bus matrix.

The STM32L475xx devices embed several protection mechanisms for embedded Flash memory and SRAM: readout protection, write protection, proprietary code readout protection and Firewall.

The devices offer up to three fast 12-bit ADCs (5 Msps), two comparators, two operational amplifiers, two DAC channels, an internal voltage reference buffer, a low-power RTC, two general-purpose 32-bit timer, two 16-bit PWM timers dedicated to motor control, seven general-purpose 16-bit timers, and two 16-bit low-power timers. The devices support four digital filters for external sigma delta modulators (DFSDM).

In addition, up to 21 capacitive sensing channels are available.

They also feature standard and advanced communication interfaces.

- Three I2Cs
- Three SPIs
- Three USARTs, two UARTs and one Low-Power UART.
- Two SAIs (Serial Audio Interfaces)
- One SDMMC
- One CAN
- One USB OTG full-speed
- One SWPMI (Single Wire Protocol Master Interface)

The STM32L475xx operates in the -40 to +85 °C (+105 °C junction), -40 to +105 °C (+125 °C junction) and -40 to +125 °C (+130 °C junction) temperature ranges from a 1.71 to 3.6 V power supply. A comprehensive set of power-saving modes allows the design of low-power applications.

Some independent power supplies are supported: analog independent supply input for ADC, DAC, OPAMPs and comparators, 3.3 V dedicated supply input for USB and up to 14 I/Os can be supplied independently down to 1.08V_A. A VBAT input allows to backup the RTC and backup registers.

The STM32L475xx family offers two packages from 64-pin to 100-pin packages.

Table 2. STM32L475xx family device features and peripheral counts

Peripheral		STM32L475Vx			STM32L475Rx		
Flash memory		256KB	512KB	1MB	256KB	512KB	1MB
SRAM		128 KB					
External memory controller for static memories		Yes ⁽¹⁾			No		
Quad SPI		Yes					
Timers	Advanced control	2 (16-bit)					
	General purpose	5 (16-bit) 2 (32-bit)					
	Basic	2 (16-bit)					
	Low -power	2 (16-bit)					
	SysTick timer	1					
	Watchdog timers (independent, window)	2					
Comm. interfaces	SPI	3					
	I ² C	3					
	USART	3					
	UART	2					
	LPUART	1					
	SAI	2					
	CAN	1					
	USB OTG FS	Yes					
SDMMC	Yes						
SWPMI	Yes						
Digital filters for sigma-delta modulators		Yes (4 filters)					
Number of channels		8					
RTC		Yes					
Tamper pins		3			2		
Random generator		Yes					
GPIOs		82			51		
Wakeup pins		5			4		
Nb of I/Os down to 1.08 V		0			0		
Capacitive sensing Number of channels		21			12		
12-bit ADCs Number of channels		3 16			3 16		
12-bit DAC channels		2					
Internal voltage reference buffer		Yes			No		
Analog comparator		2					
Operational amplifiers		2					
Max. CPU frequency		80 MHz					
Operating voltage		1.71 to 3.6 V					
Operating temperature		Ambient operating temperature: -40 to 85 °C / -40 to 105 °C / -40 to 125 °C Junction temperature: -40 to 105 °C / -40 to 125 °C / -40 to 130 °C					
Packages		LQFP100			LQFP64		

1. For the LQFP100 package, only FMC Bank1 is available. Bank1 can only support a multiplexed NOR/PSRAM memory using the NE1 Chip Select.

Figure 1. STM32L475xx block diagram

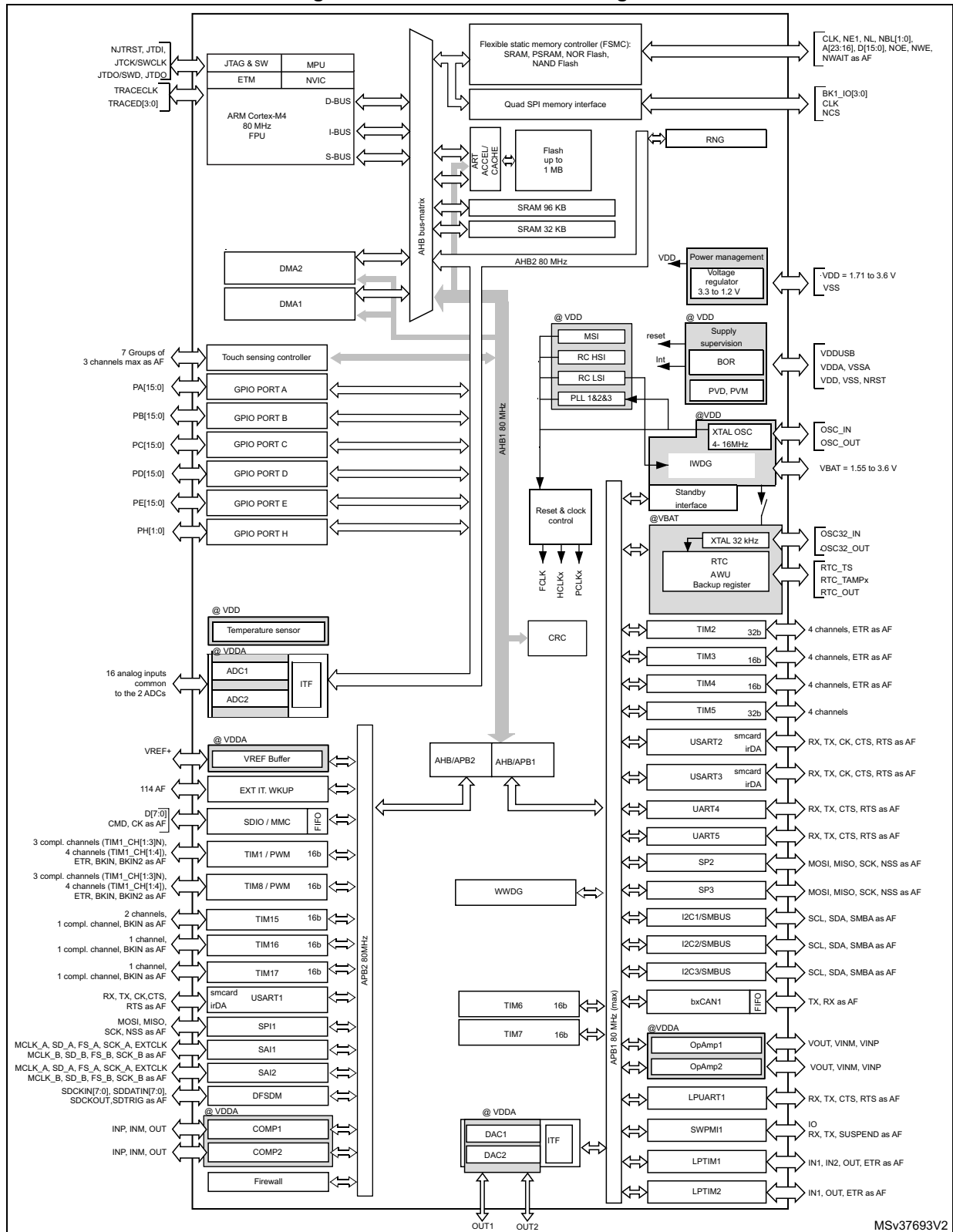

Note: AF: alternate function on I/O pins.



3 Functional overview

3.1 ARM[®] Cortex[®]-M4 core with FPU

The ARM[®] Cortex[®]-M4 with FPU processor is the latest generation of ARM processors for embedded systems. It was developed to provide a low-cost platform that meets the needs of MCU implementation, with a reduced pin count and low-power consumption, while delivering outstanding computational performance and an advanced response to interrupts.

The ARM[®] Cortex[®]-M4 with FPU 32-bit RISC processor features exceptional code-efficiency, delivering the high-performance expected from an ARM core in the memory size usually associated with 8- and 16-bit devices.

The processor supports a set of DSP instructions which allow efficient signal processing and complex algorithm execution.

Its single precision FPU speeds up software development by using metalanguage development tools, while avoiding saturation.

With its embedded ARM core, the STM32L475xx family is compatible with all ARM tools and software.

Figure 1 shows the general block diagram of the STM32L475xx family devices.

3.2 Adaptive real-time memory accelerator (ART Accelerator™)

The ART Accelerator™ is a memory accelerator which is optimized for STM32 industry-standard ARM[®] Cortex[®]-M4 processors. It balances the inherent performance advantage of the ARM[®] Cortex[®]-M4 over Flash memory technologies, which normally requires the processor to wait for the Flash memory at higher frequencies.

To release the processor near 100 DMIPS performance at 80MHz, the accelerator implements an instruction prefetch queue and branch cache, which increases program execution speed from the 64-bit Flash memory. Based on CoreMark benchmark, the performance achieved thanks to the ART accelerator is equivalent to 0 wait state program execution from Flash memory at a CPU frequency up to 80 MHz.

3.3 Memory protection unit

The memory protection unit (MPU) is used to manage the CPU accesses to memory to prevent one task to accidentally corrupt the memory or resources used by any other active task. This memory area is organized into up to 8 protected areas that can in turn be divided up into 8 subareas. The protection area sizes are between 32 bytes and the whole 4 gigabytes of addressable memory.

The MPU is especially helpful for applications where some critical or certified code has to be protected against the misbehavior of other tasks. It is usually managed by an RTOS (real-time operating system). If a program accesses a memory location that is prohibited by the MPU, the RTOS can detect it and take action. In an RTOS environment, the kernel can dynamically update the MPU area setting, based on the process to be executed.

The MPU is optional and can be bypassed for applications that do not need it.

3.4 Embedded Flash memory

STM32L475xx devices feature up to 1 Mbyte of embedded Flash memory available for storing programs and data. The Flash memory is divided into two banks allowing read-while-write operations. This feature allows to perform a read operation from one bank while an erase or program operation is performed to the other bank. The dual bank boot is also supported. Each bank contains 256 pages of 2 Kbyte.

Flexible protections can be configured thanks to option bytes:

- Readout protection (RDP) to protect the whole memory. Three levels are available:
 - Level 0: no readout protection
 - Level 1: memory readout protection: the Flash memory cannot be read from or written to if either debug features are connected, boot in RAM or bootloader is selected
 - Level 2: chip readout protection: debug features (Cortex-M4 JTAG and serial wire), boot in RAM and bootloader selection are disabled (JTAG fuse). This selection is irreversible.

Table 3. Access status versus readout protection level and execution modes

Area	Protection level	User execution			Debug, boot from RAM or boot from system memory (loader)		
		Read	Write	Erase	Read	Write	Erase
Main memory	1	Yes	Yes	Yes	No	No	No
	2	Yes	Yes	Yes	N/A	N/A	N/A
System memory	1	Yes	No	No	Yes	No	No
	2	Yes	No	No	N/A	N/A	N/A
Option bytes	1	Yes	Yes	Yes	Yes	Yes	Yes
	2	Yes	No	No	N/A	N/A	N/A
Backup registers	1	Yes	Yes	N/A ⁽¹⁾	No	No	N/A ⁽¹⁾
	2	Yes	Yes	N/A	N/A	N/A	N/A
SRAM2	1	Yes	Yes	Yes ⁽¹⁾	No	No	No ⁽¹⁾
	2	Yes	Yes	Yes	N/A	N/A	N/A

1. Erased when RDP change from Level 1 to Level 0.

- Write protection (WRP): the protected area is protected against erasing and programming. Two areas per bank can be selected, with 2-Kbyte granularity.
- Proprietary code readout protection (PCROP): a part of the flash memory can be protected against read and write from third parties. The protected area is execute-only: it can only be reached by the STM32 CPU, as an instruction code, while all other accesses (DMA, debug and CPU data read, write and erase) are strictly prohibited. One area per bank can be selected, with 64-bit granularity. An additional option bit (PCROP_RDP) allows to select if the PCROP area is erased or not when the RDP protection is changed from Level 1 to Level 0.

The whole non-volatile memory embeds the error correction code (ECC) feature supporting:

- single error detection and correction
- double error detection.
- The address of the ECC fail can be read in the ECC register

3.5 Embedded SRAM

STM32L475xx devices feature up to 128 Kbyte of embedded SRAM. This SRAM is split into two blocks:

- 96 Kbyte mapped at address 0x2000 0000 (SRAM1)
- 32 Kbyte located at address 0x1000 0000 with hardware parity check (SRAM2).
This block is accessed through the ICode/DCode buses for maximum performance. These 32 Kbyte SRAM can also be retained in Standby mode.
The SRAM2 can be write-protected with 1 Kbyte granularity.

The memory can be accessed in read/write at CPU clock speed with 0 wait states.

3.6 Firewall

The device embeds a Firewall which protects code sensitive and secure data from any access performed by a code executed outside of the protected areas.

Each illegal access generates a reset which kills immediately the detected intrusion.

The Firewall main features are the following:

- Three segments can be protected and defined thanks to the Firewall registers:
 - Code segment (located in Flash or SRAM1 if defined as executable protected area)
 - Non-volatile data segment (located in Flash)
 - Volatile data segment (located in SRAM1)
- The start address and the length of each segments are configurable:
 - code segment: up to 1024 Kbyte with granularity of 256 bytes
 - Non-volatile data segment: up to 1024 Kbyte with granularity of 256 bytes
 - Volatile data segment: up to 96 Kbyte with a granularity of 64 bytes
- Specific mechanism implemented to open the Firewall to get access to the protected areas (call gate entry sequence)
- Volatile data segment can be shared or not with the non-protected code
- Volatile data segment can be executed or not depending on the Firewall configuration

The Flash readout protection must be set to level 2 in order to reach the expected level of protection.

3.7 Boot modes

At startup, BOOT0 pin and BOOT1 option bit are used to select one of three boot options:

- Boot from user Flash
- Boot from system memory
- Boot from embedded SRAM

The boot loader is located in system memory. It is used to reprogram the Flash memory by using USART, I2C, SPI, CAN and USB OTG FS in Device mode through DFU (device firmware upgrade).

3.8 Cyclic redundancy check calculation unit (CRC)

The CRC (cyclic redundancy check) calculation unit is used to get a CRC code using a configurable generator polynomial value and size.

Among other applications, CRC-based techniques are used to verify data transmission or storage integrity. In the scope of the EN/IEC 60335-1 standard, they offer a means of verifying the Flash memory integrity. The CRC calculation unit helps compute a signature of the software during runtime, to be compared with a reference signature generated at link-time and stored at a given memory location.

3.9 Power supply management

3.9.1 Power supply schemes

- $V_{DD} = 1.71$ to 3.6 V: external power supply for I/Os (V_{DDIO1}), the internal regulator and the system analog such as reset, power management and internal clocks. It is provided externally through V_{DD} pins.
- $V_{DDA} = 1.62$ V (ADCs/COMP) / 1.8 (DACs/OPAMP) to 3.6 V: external analog power supply for ADCs, DACs, OPAMPs, Comparators and Voltage reference buffer. The V_{DDA} voltage level is independent from the V_{DD} voltage.
- $V_{DDUSB} = 3.0$ to 3.6 V: external independent power supply for USB transceivers. The V_{DDUSB} voltage level is independent from the V_{DD} voltage.
- $V_{BAT} = 1.55$ to 3.6 V: power supply for RTC, external clock 32 kHz oscillator and backup registers (through power switch) when V_{DD} is not present.

Note: When the functions supplied by V_{DDA} or V_{DDUSB} are not used, these supplies should preferably be shorted to V_{DD} .

Note: If these supplies are tied to ground, the I/Os supplied by these power supplies are not 5 V tolerant (refer to [Table 19: Voltage characteristics](#)).

Note: V_{DDIOx} is the I/Os general purpose digital functions supply. V_{DDIOx} represents V_{DDIO1} , with $V_{DDIO1} = V_{DD}$.

Figure 2. Power supply overview

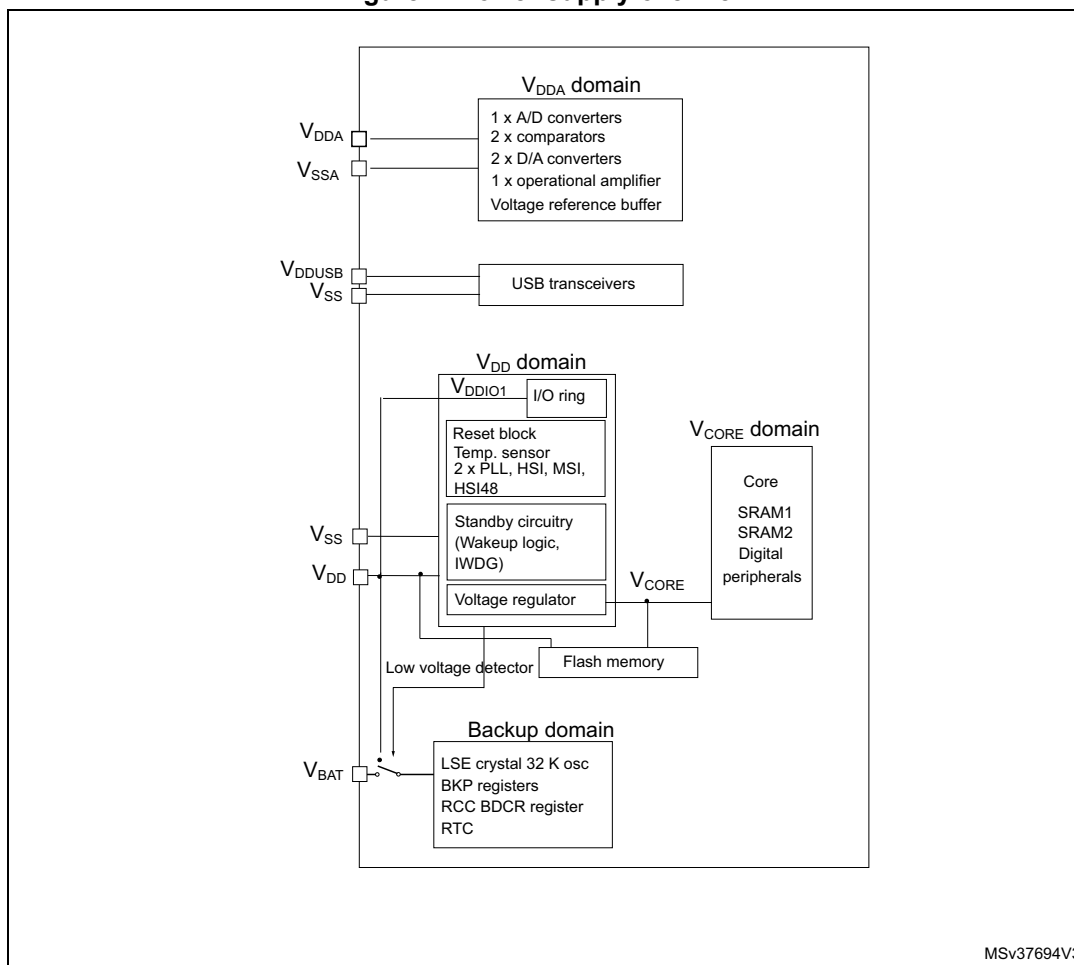

MSv37694V3

3.9.2 Power supply supervisor

The device has an integrated ultra-low-power brown-out reset (BOR) active in all modes except Shutdown and ensuring proper operation after power-on and during power down. The device remains in reset mode when the monitored supply voltage V_{DD} is below a specified threshold, without the need for an external reset circuit.

The lowest BOR level is 1.71V at power on, and other higher thresholds can be selected through option bytes. The device features an embedded programmable voltage detector (PVD) that monitors the V_{DD} power supply and compares it to the $VPVD$ threshold. An interrupt can be generated when V_{DD} drops below the $VPVD$ threshold and/or when V_{DD} is higher than the $VPVD$ threshold. The interrupt service routine can then generate a warning message and/or put the MCU into a safe state. The PVD is enabled by software.

In addition, the devices embeds a Peripheral Voltage Monitor which compares the independent supply voltages V_{DDA} , V_{DDUSB} with a fixed threshold in order to ensure that the peripheral is in its functional supply range.

3.9.3 Voltage regulator

Two embedded linear voltage regulators supply most of the digital circuitries: the main regulator (MR) and the low-power regulator (LPR).

- The MR is used in the Run and Sleep modes and in the Stop 0 mode.
- The LPR is used in Low-Power Run, Low-Power Sleep, Stop 1 and Stop 2 modes. It is also used to supply the 32 Kbyte SRAM2 in Standby with RAM2 retention.
- Both regulators are in power-down in Standby and Shutdown modes: the regulator output is in high impedance, and the kernel circuitry is powered down thus inducing zero consumption.

The ultralow-power STM32L475xx supports dynamic voltage scaling to optimize its power consumption in run mode. The voltage from the Main Regulator that supplies the logic (V_{CORE}) can be adjusted according to the system's maximum operating frequency.

There are two power consumption ranges:

- Range 1 with the CPU running at up to 80 MHz.
- Range 2 with a maximum CPU frequency of 26 MHz. All peripheral clocks are also limited to 26 MHz.

The V_{CORE} can be supplied by the low-power regulator, the main regulator being switched off. The system is then in Low-power run mode.

- Low-power run mode with the CPU running at up to 2 MHz. Peripherals with independent clock can be clocked by HSI16.

3.9.4 Low-power modes

The ultra-low-power STM32L475xx supports seven low-power modes to achieve the best compromise between low-power consumption, short startup time, available peripherals and available wakeup sources:

Table 4. STM32L475 modes overview

Mode	Regulator ⁽¹⁾	CPU	Flash	SRAM	Clocks	DMA & Peripherals ⁽²⁾	Wakeup source	Consumption ⁽³⁾	Wakeup time
Run	Range 1	Yes	ON ⁽⁴⁾	ON	Any	All	N/A	112 µA/MHz	N/A
	Range2					All except OTG_FS, RNG		100 µA/MHz	
LPRun	LPR	Yes	ON ⁽⁴⁾	ON	Any except PLL	All except OTG_FS, RNG	N/A	136 µA/MHz	to Range 1: 4 µs to Range 2: 64 µs
Sleep	Range 1	No	ON ⁽⁴⁾	ON ⁽⁵⁾	Any	All	Any interrupt or event	37 µA/MHz	6 cycles
	Range 2					All except OTG_FS, RNG		35 µA/MHz	6 cycles
LPSleep	LPR	No	ON ⁽⁴⁾	ON ⁽⁵⁾	Any except PLL	All except OTG_FS, RNG	Any interrupt or event	40 µA/MHz	6 cycles
Stop 0	Range 1	No	Off	ON	LSE LSI	BOR, PVD, PVM RTC,IWDG COMPx (x=1,2) DACx (x=1,2) OPAMPx (x=1,2) USARTx (x=1...5) ⁽⁶⁾ LPUART1 ⁽⁶⁾ I2Cx (x=1...3) ⁽⁷⁾ LPTIMx (x=1,2) *** All other peripherals are frozen.	Reset pin, all I/Os BOR, PVD, PVM RTC,IWDG COMPx (x=1..2) USARTx (x=1...5) ⁽⁶⁾ LPUART1 ⁽⁶⁾ I2Cx (x=1...3) ⁽⁷⁾ LPTIMx (x=1,2) OTG_FS ⁽⁸⁾ SWPMI1 ⁽⁹⁾	108 µA	0.7 µs in SRAM 4.5 µs in Flash
	Range 2								



Table 4. STM32L475 modes overview (continued)

Mode	Regulator ⁽¹⁾	CPU	Flash	SRAM	Clocks	DMA & Peripherals ⁽²⁾	Wakeup source	Consumption ⁽³⁾	Wakeup time
Stop 1	LPR	No	Off	ON	LSE LSI	BOR, PVD, PVM RTC, IWDG COMPx (x=1,2) DACx (x=1,2) OPAMPx (x=1,2) USARTx (x=1...5) ⁽⁶⁾ LPUART1 ⁽⁶⁾ I2Cx (x=1...3) ⁽⁷⁾ LPTIMx (x=1,2) *** All other peripherals are frozen.	Reset pin, all I/Os BOR, PVD, PVM RTC, IWDG COMPx (x=1..2) USARTx (x=1...5) ⁽⁶⁾ LPUART1 ⁽⁶⁾ I2Cx (x=1...3) ⁽⁷⁾ LPTIMx (x=1,2) OTG_FS ⁽⁸⁾ SWPMI1 ⁽⁹⁾	6.6 μ A w/o RTC 6.9 μ A w RTC	4 μ s in SRAM 6 μ s in Flash
Stop 2	LPR	No	Off	ON	LSE LSI	BOR, PVD, PVM RTC, IWDG COMPx (x=1..2) I2C3 ⁽⁷⁾ LPUART1 ⁽⁶⁾ LPTIM1 *** All other peripherals are frozen.	Reset pin, all I/Os BOR, PVD, PVM RTC, IWDG COMPx (x=1..2) I2C3 ⁽⁷⁾ LPUART1 ⁽⁶⁾ LPTIM1	1.1 μ A w/o RTC 1.4 μ A w/RTC	5 μ s in SRAM 7 μ s in Flash

Table 4. STM32L475 modes overview (continued)

Mode	Regulator ⁽¹⁾	CPU	Flash	SRAM	Clocks	DMA & Peripherals ⁽²⁾	Wakeup source	Consumption ⁽³⁾	Wakeup time
Standby	LPR	Powered Off	Off	SRAM2 ON	LSE LSI	BOR, RTC, IWDG ***	Reset pin 5 I/Os (WKUPx) ⁽¹⁰⁾ BOR, RTC, IWDG	0.35 μ A w/o RTC 0.65 μ A w/ RTC	14 μ s
	OFF			Powered Off		All other peripherals are powered off. *** I/O configuration can be floating, pull-up or pull-down		0.12 μ A w/o RTC 0.42 μ A w/ RTC	
Shutdown	OFF	Powered Off	Off	Powered Off	LSE	RTC *** All other peripherals are powered off. *** I/O configuration can be floating, pull-up or pull-down ⁽¹¹⁾	Reset pin 5 I/Os (WKUPx) ⁽¹⁰⁾ RTC	0.03 μ A w/o RTC 0.33 μ A w/ RTC	256 μ s

1. LPR means Main regulator is OFF and Low-power regulator is ON.
2. All peripherals can be active or clock gated to save power consumption.
3. Typical current at $V_{DD} = 1.8$ V, 25°C. Consumptions values provided running from SRAM, Flash memory Off, 80 MHz in Range 1, 26 MHz in Range 2, 2 MHz in LPRun/LPSleep.
4. The Flash memory can be put in power-down and its clock can be gated off when executing from SRAM.
5. The SRAM1 and SRAM2 clocks can be gated on or off independently.
6. U(S)ART and LPUART reception is functional in Stop mode, and generates a wakeup interrupt on Start, address match or received frame event.
7. I2C address detection is functional in Stop mode, and generates a wakeup interrupt in case of address match.
8. OTG_FS wakeup by resume from suspend and attach detection protocol event.
9. SWPMI1 wakeup by resume from suspend.
10. The I/Os with wakeup from Standby/Shutdown capability are: PA0, PC13, PE6, PA2, PC5.
11. I/Os can be configured with internal pull-up, pull-down or floating in Shutdown mode but the configuration is lost when exiting the Shutdown mode.

By default, the microcontroller is in Run mode after a system or a power Reset. It is up to the user to select one of the low-power modes described below:

- **Sleep mode**

In Sleep mode, only the CPU is stopped. All peripherals continue to operate and can wake up the CPU when an interrupt/event occurs.

- **Low-power run mode**

This mode is achieved with VCORE supplied by the low-power regulator to minimize the regulator's operating current. The code can be executed from SRAM or from Flash, and the CPU frequency is limited to 2 MHz. The peripherals with independent clock can be clocked by HSI16.

- **Low-power sleep mode**

This mode is entered from the low-power run mode. Only the CPU clock is stopped. When wakeup is triggered by an event or an interrupt, the system reverts to the low-power run mode.

- **Stop 0, Stop 1 and Stop 2 modes**

Stop mode achieves the lowest power consumption while retaining the content of SRAM and registers. All clocks in the VCORE domain are stopped, the PLL, the MSI RC, the HSI16 RC and the HSE crystal oscillators are disabled. The LSE or LSI is still running.

The RTC can remain active (Stop mode with RTC, Stop mode without RTC).

Some peripherals with wakeup capability can enable the HSI16 RC during Stop mode to detect their wakeup condition.

Three Stop modes are available: Stop 0, Stop 1 and Stop 2 modes. In Stop 2 mode, most of the VCORE domain is put in a lower leakage mode.

Stop 1 offers the largest number of active peripherals and wakeup sources, a smaller wakeup time but a higher consumption than Stop 2. In Stop 0 mode, the main regulator remains ON, allowing a very fast wakeup time but with much higher consumption.

The system clock when exiting from Stop 0, Stop1 or Stop2 modes can be either MSI up to 48 MHz or HSI16, depending on software configuration.

- **Standby mode**

The Standby mode is used to achieve the lowest power consumption with BOR. The internal regulator is switched off so that the VCORE domain is powered off. The PLL, the MSI RC, the HSI16 RC and the HSE crystal oscillators are also switched off.

The RTC can remain active (Standby mode with RTC, Standby mode without RTC).

The brown-out reset (BOR) always remains active in Standby mode.

The state of each I/O during standby mode can be selected by software: I/O with internal pull-up, internal pull-down or floating.

After entering Standby mode, SRAM1 and register contents are lost except for registers in the Backup domain and Standby circuitry. Optionally, SRAM2 can be retained in

Standby mode, supplied by the low-power Regulator (Standby with RAM2 retention mode).

The device exits Standby mode when an external reset (NRST pin), an IWDG reset, WKUP pin event (configurable rising or falling edge), or an RTC event occurs (alarm, periodic wakeup, timestamp, tamper) or a failure is detected on LSE (CSS on LSE).

The system clock after wakeup is MSI up to 8 MHz.

- **Shutdown mode**

The Shutdown mode allows to achieve the lowest power consumption. The internal regulator is switched off so that the VCORE domain is powered off. The PLL, the HSI16, the MSI, the LSI and the HSE oscillators are also switched off.

The RTC can remain active (Shutdown mode with RTC, Shutdown mode without RTC).

The BOR is not available in Shutdown mode. No power voltage monitoring is possible in this mode, therefore the switch to Backup domain is not supported.

SRAM1, SRAM2 and register contents are lost except for registers in the Backup domain.

The device exits Shutdown mode when an external reset (NRST pin), a WKUP pin event (configurable rising or falling edge), or an RTC event occurs (alarm, periodic wakeup, timestamp, tamper).

The system clock after wakeup is MSI at 4 MHz.