



Chipsmall Limited consists of a professional team with an average of over 10 year of expertise in the distribution of electronic components. Based in Hongkong, we have already established firm and mutual-benefit business relationships with customers from,Europe,America and south Asia,supplying obsolete and hard-to-find components to meet their specific needs.

With the principle of “Quality Parts,Customers Priority,Honest Operation,and Considerate Service”,our business mainly focus on the distribution of electronic components. Line cards we deal with include Microchip,ALPS,ROHM,Xilinx,Pulse,ON,Everlight and Freescale. Main products comprise IC,Modules,Potentiometer,IC Socket,Relay,Connector.Our parts cover such applications as commercial,industrial, and automotives areas.

We are looking forward to setting up business relationship with you and hope to provide you with the best service and solution. Let us make a better world for our industry!



Contact us

Tel: +86-755-8981 8866 Fax: +86-755-8427 6832

Email & Skype: info@chipsmall.com Web: www.chipsmall.com

Address: A1208, Overseas Decoration Building, #122 Zhenhua RD., Futian, Shenzhen, China



7-channel MUX/DEMUX for analog video signal

Features

- Low R_{ON} : 4.0 Ω typical
- V_{CC} operating range: 3.0 to 3.6 V
- Enhanced ESD protection: > 8 kV (contact) and 8 kV (HBM)
- Channel on capacitance: 7.8 pF typical
- Designed for VGA signal switching
- Integrated switches for RGB, HSYNC, VSYNC and DDC signals
- Very low crosstalk: -45 dB at 250 MHz
- > 1000 MHz -3 dB typical bandwidth (or data frequency)
- Low power mode for minimum power consumption
- Package: QFN32L

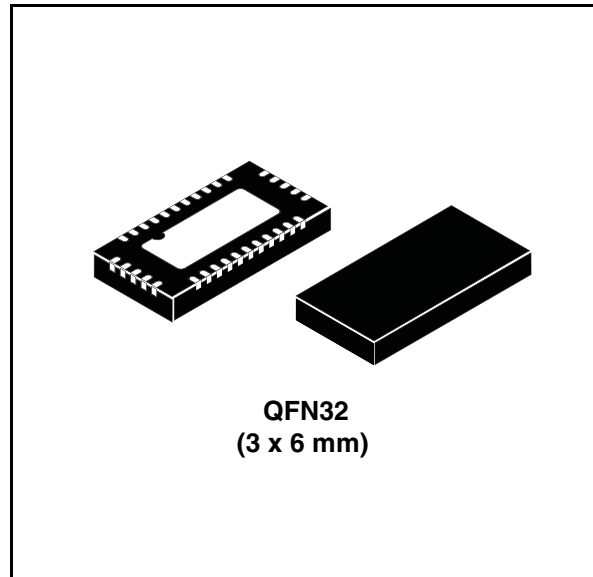

Applications

- Audio/video switching

Description

The STMUX7000 is a 7-channel multiplexer/demultiplexer low R_{ON} bidirectional designed for analog video signal, such as VGA. It is designed for very low crosstalk, and high bandwidth to maintain high signal integrity.

The analog video signal multiplexed from one of two selected sources in the notebook and docking station while the unselected switch goes to Hi-Z status.

The device is also protected against high ESD that supports up to 8 kV contact on all I/O pins.

The device can be put into low power mode consuming minimum power.

Table 1. Device summary

Order code	Package	Packing
STMUX7000QTR	QFN32 (3 x 6 x 0.8 mm)	Tape and reel

Contents

1	Pin description	3
2	Maximum rating	5
	2.1 Recommended operating conditions	5
3	Electrical characteristics	6
4	Package mechanical data	14
5	Revision history	18

1 Pin description

Figure 1. Pin connection (top through view)

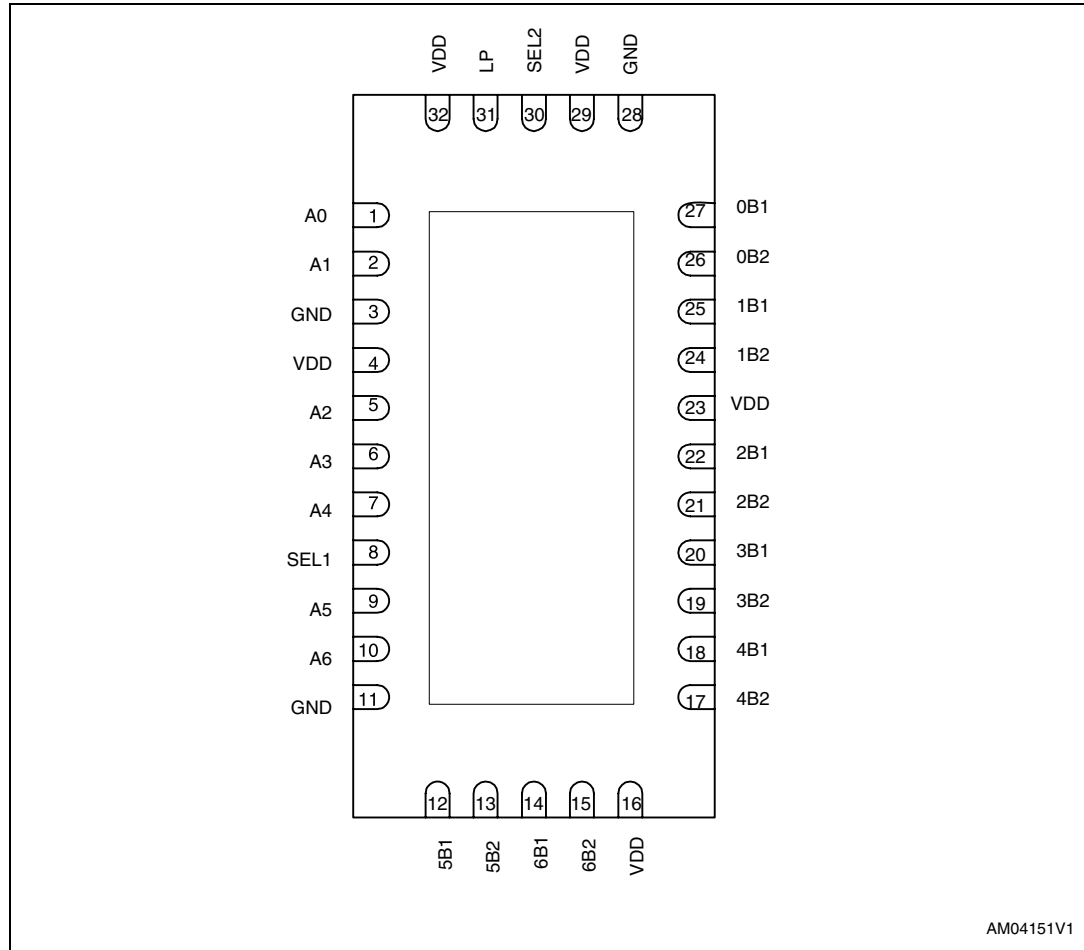
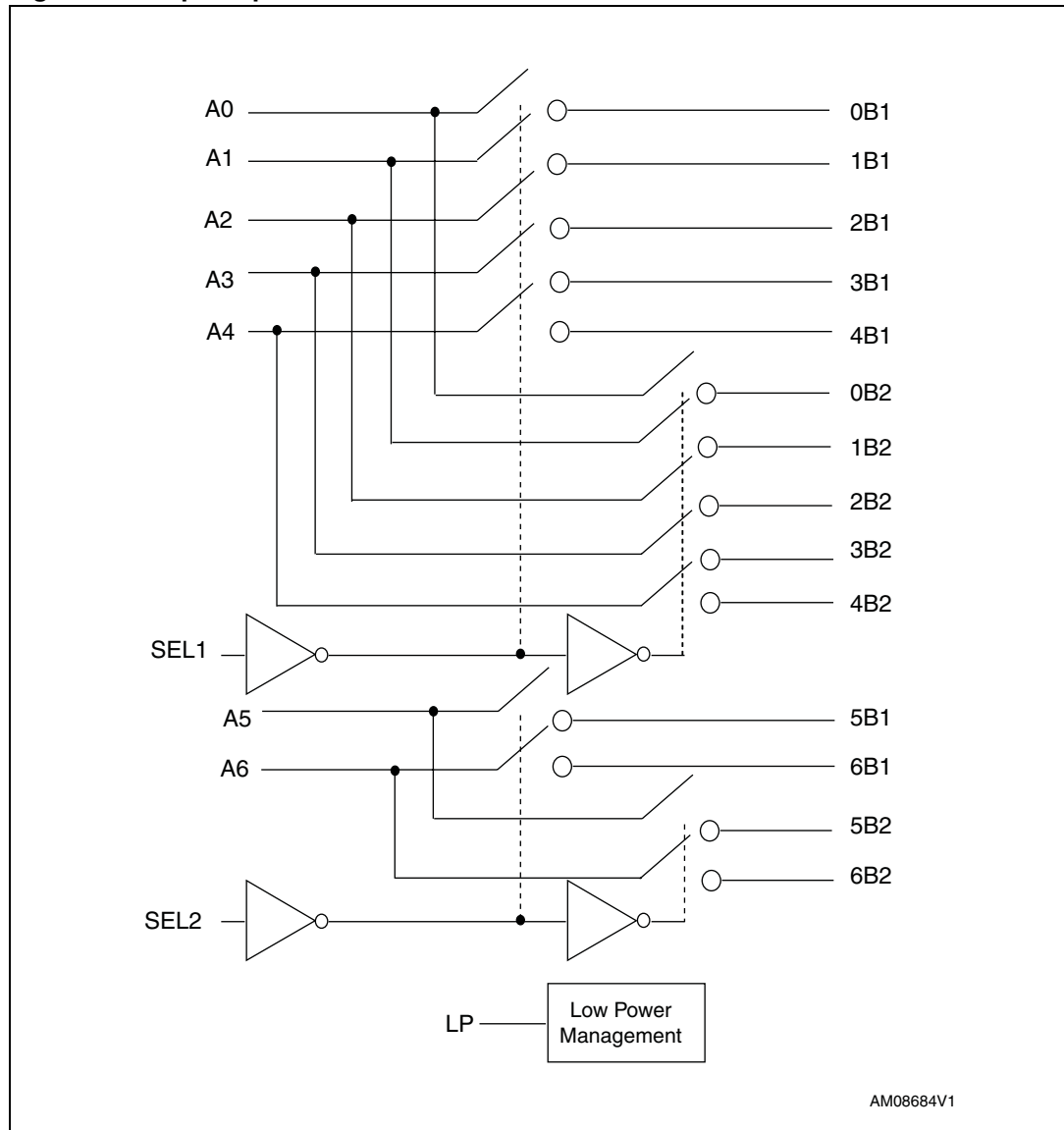

Table 2. Pin description

Pin	Symbol	Name and function
8	SEL 1	Selecion for bit 0, 1, 2, 3, 4
30	SEL 2	Selection for bit 5, 6
1, 2, 5, 6, 7, 9, 10	A0, A1, A2, A3, A4, A5, A6	8-bit bus
4, 16, 23, 29, 32	VDD	Supply voltage
3, 11, 28	GND	Ground
27, 25, 22, 20, 18, 14, 12	0B1, 1B1, 2B1, 3B1, 4B1, 5B1, 6B1	8-bit multiplexed to bus 1
26, 24, 21, 19, 17, 15, 13	0B2, 1B2, 2B2, 3B2, 4B2, 5B2, 6B2	8-bit multiplexed to bus 2
31	LP	Low power mode enable

Figure 2. Input equivalent circuit



AM08684V1

Table 3. Bit 0, 1, 2, 3, 4 switch function table

LP	SEL 1	Function
L	L	Bit 0, 1, 2, 3, 4 multiplexed to bus 1, bus 2 in Hi-Z
L	H	Bit 0, 1, 2, 3, 4 multiplexed to bus 2, bus 1 in Hi-Z
H	X	Bus 1 and 2 in Hi-Z

Table 4. Bit 5, 6 switch function table

LP	SEL 2	Function
L	L	Bit 5,6 multiplexed to bus 1, bus 2 in Hi-Z

Table 4. Bit 5, 6 switch function table

LP	SEL 2	Function
L	H	Bit 5,6 multiplexed to bus 2, bus 1 in Hi-Z
H	X	Bus 1 and 2 in Hi-Z

2 Maximum rating

Stressing the device above the rating listed in the “absolute maximum ratings” table may cause permanent damage to the device. These are stress ratings only and operation of the device at these or any other conditions above those indicated in the operating sections of this specification is not implied. Exposure to absolute maximum rating conditions for extended periods may affect device reliability.

Table 5. Absolute maximum ratings

Symbol	Parameter	Value	Unit
V_{CC}	Supply voltage to ground	-0.5 to 4.6	V
V_{IO}	DC input output voltage	-0.5 to 4.6	V
V_{IC}	DC control input voltage	-0.5 to 4.6	V
I_O	DC output current ⁽¹⁾	120	mA
P_D	Power dissipation	0.5	W
T_{stg}	Storage temperature	-65 to 150	°C
T_L	Lead temperature (10 sec)	300	°C

1. If $V_{IO} \times I_O$ does not exceed the maximum limit of P_D .

2.1 Recommended operating conditions

Table 6. Recommended operating conditions

Symbol	Parameter	Value			Unit
		Min	Typ	Max	
V_{CC}	Supply voltage to ground	3	-	3.6	V
V_{IC}	DC control input voltage (SEL, LP)	0	-	5	V
V_{IO}	DC input/output voltage	0	-	V_{CC}	V
T_A	Operating temperature	-40	-	85	°C

3 Electrical characteristics

Table 7. DC electrical characteristics ($V_{CC} = 3.3 \text{ V} \pm 10\%$)

Symbol	Parameter	Test condition	Value			Unit
			-40 to 85 °C			
			Min	Typ	Max	
V_{IH}	Voltage input high (SEL, LP)	High level guaranteed	2	-	-	V
V_{IL}	Voltage input low (SEL, LP)	Low level guaranteed	-0.5	-	0.8	V
V_{IK}	Clamp diode voltage (SEL, LP)	$V_{CC} = 3.6 \text{ V}$ $I_{IN} = -18 \text{ mA}$	-	-0.8	-1.2	V
I_{IH}	Input high current (SEL, LP)	$V_{CC} = 3.6 \text{ V}$ $V_{IN} = V_{CC}$	-	-	± 5	μA
I_{IL}	Input low current (SEL, LP)	$V_{CC} = 3.6 \text{ V}$ $V_{IN} = \text{GND}$	-	-	± 5	μA
$I_{OFF(SW)}^{(1)}$	Leakage current through the switch common terminals (A to H) (LED1 to LED3)	$V_{CC} = 3.6 \text{ V}$ A to H = V_{CC} LED1 to LED3 = V_{CC} A0 to H0 = 0 V A1 to H1 = floating LEDx_0 = 0 V LEDx1 = floating SEL = V_{CC}	-	-	± 1	μA
$I_{OFF(SEL, LP)}$	SEL, LP pin leakage current	$V_{CC} = 0 \text{ V}$ SEL = 0 to 3.6 V	-	-	± 1	μA
R_{ON}	Switch ON resistance ⁽²⁾	$V_{CC} = 3.0 \text{ V}$ $V_{IN} = 0 \text{ to } 1.2 \text{ V}$ $I_{IN} = -40 \text{ mA}$	-	4.0	6.5	Ω
R_{FLAT}	ON resistance flatness ⁽²⁾ ⁽³⁾	$V_{CC} = 3.0 \text{ V}$ V_{IN} at 0 and 1.2 V $I_{IN} = -40 \text{ mA}$	-	0.5	-	Ω
ΔR_{ON}	ON resistance match between channel $\Delta R_{ON} = R_{ONMAX} - R_{ONMIN}$ ⁽²⁾⁽⁴⁾	$V_{CC} = 3.0 \text{ V}$ $V_{IN} = 0 \text{ to } 1.2 \text{ V}$ $I_{IN} = -40 \text{ mA}$	-	0.4	1	Ω

1. Refer to [Figure 4: Test circuit for leakage current \(IOFF\) on page 10](#)

2. Measured by voltage drop between channels at indicated current through the switch. ON resistance is determined by the lower of the voltages.

3. Flatness is defined as the difference between the R_{ONMAX} and R_{ONMIN} of ON resistance over the specified range.

4. ΔR_{ON} measured at same V_{CC} , temperature and voltage level.

Table 8. Capacitance ($T_A = 25\text{ °C}$, $f = 1\text{ MHz}$)

Symbol	Parameter	Test condition	Value			Unit
			Min	Typ	Max	
C_{IN}	SEL, LP pin input capacitance ⁽¹⁾	DC = 0.25 V AC = 0.5 V _{PP} f = 1 MHz	-	2	3	pF
C_{OFF}	Switch off capacitance ⁽²⁾	DC = 0.25 V AC = 0.5 V _{PP} f = 1 MHz	-	2.8	6.5	pF
C_{ON}	Switch on capacitance ⁽³⁾	DC = 0.25 V AC = 0.5 V _{PP} f = 1 MHz	-	7.8	-	pF

1. Refer to [Figure 5 on page 11](#).
2. Refer to [Figure 6 on page 11](#).
3. Refer to [Figure 7 on page 12](#).

Table 9. Power supply characteristics

Symbol	Parameter	Test condition	Value			Unit
			-40 to 85 °C			
			Min	Typ	Max	
I_{CC}	Active mode power supply current	$V_{CC} = 3.6\text{ V}$, $V_{IN} = V_{CC}$ or GND, LP = GND	-	150	500	μA
I_{CC}	Low power mode power supply current	$V_{CC} = 3.6\text{ V}$, $V_{IN} = V_{CC}$ or GND, LP = V_{CC}	-	10	15	μA

Table 10. Dynamic electrical characteristics ($V_{CC} = 3.3\text{ V} \pm 10\%$)

Symbol	Parameter	Test condition	Value			Unit
			-40 to 85 °C			
			Min	Typ	Max	
X_{talk}	Crosstalk ⁽¹⁾	$R_L = 50\ \Omega$, $R_S = 50\ \Omega$ f = 250 MHz	-	-45	-	dB
O_{IRR}	Off isolation ⁽²⁾	$R_L = 50\ \Omega$, $R_S = 50\ \Omega$ f = 250 MHz	-	-32	-	dB
BW	-3 dB bandwidth ⁽³⁾	$R_L = 50\ \Omega$, $R_S = 50\ \Omega$ $0 < V_{IN} \leq 1.2\text{ V}$	-	1000	-	MHz

1. Refer to [Figure 9 on page 13](#).
2. Refer to [Figure 10 on page 14](#).
3. Refer to [Figure 8 on page 12](#).

Table 11. Switching characteristics ($T_A = 25\text{ °C}$, $V_{CC} = 3.3\text{ V} \pm 10\%$)

Symbol	Parameter	Test condition	Value			Unit
			Min	Typ	Max	
t_{PD}	Propagation delay	$V_{CC} = 3\text{ to }3.6\text{ V}$	-	0.25	-	ns
t_{PZH} , t_{PZL}	Line enable time, SE to x to x0 or x to x1	$V_{CC} = 3\text{ to }3.6\text{ V}$ 1 K Ω pull up/down resistor at xb1 or xB2	0.5	6.5	15	ns
t_{PHZ} , t_{PLZ}	Line disable time, SE to x to x0 or x to x1	$V_{CC} = 3\text{ to }3.6\text{ V}$ 1 K Ω pull up/down resistor at xb1 or xB2	0.5	16		ns
$t_{SK(O)}$	Output skew between center port to any other port	$V_{CC} = 3\text{ to }3.6\text{ V}$	-	0.1	0.2	ns
$t_{SK(P)}$	Skew between opposite transition of the same output (t_{PHL} , t_{PLH})	$V_{CC} = 3\text{ to }3.6\text{ V}$	-	0.1	0.2	ns

Table 12. ESD performance

Symbol	Test condition	Value			Unit
		Min	Typ	Max	
ESD	Contact discharge ⁽¹⁾ IEC61000-4-2	-	± 8	-	kV
	Human body model (JESD22-A114)	-	± 8	-	kV

1. Refer to [Figure 3: Diagram for suggested VDD decoupling on page 10](#).

Figure 3. Diagram for suggested V_{DD} decoupling

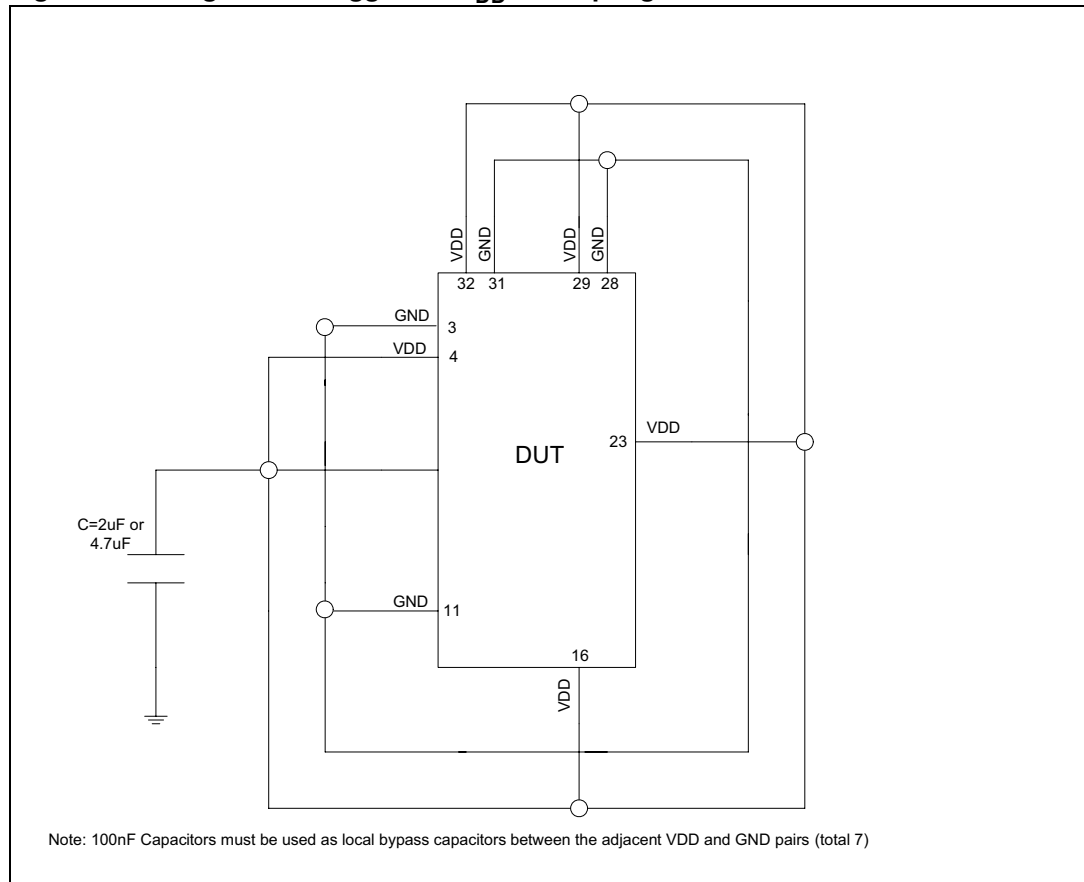

1. Applicable for system level ESD test

Figure 4. Test circuit for leakage current (I_{OFF})

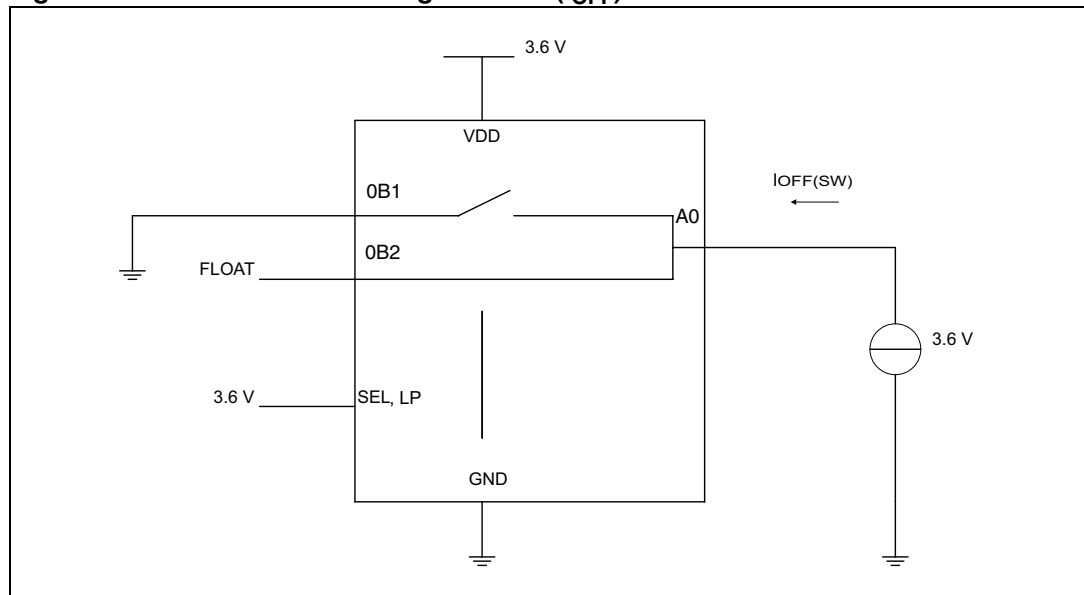

Figure 5. Test circuit for SEL pin input capacitance (C_{IN})

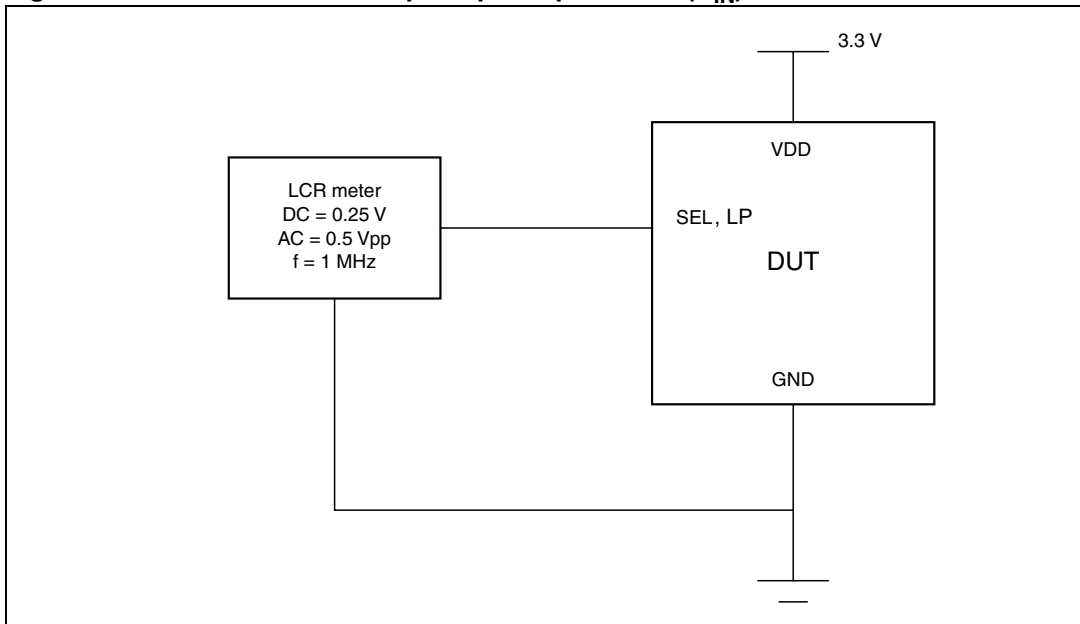

Figure 6. Test circuit for switch off capacitance (C_{OFF})

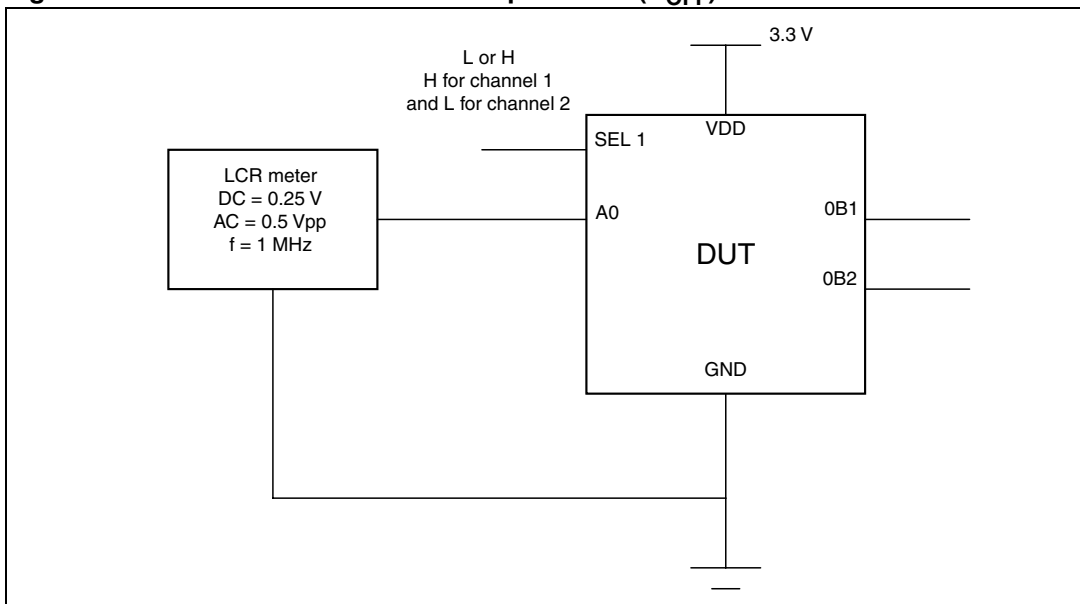

Figure 7. Test circuit for switch on capacitance (C_{ON})

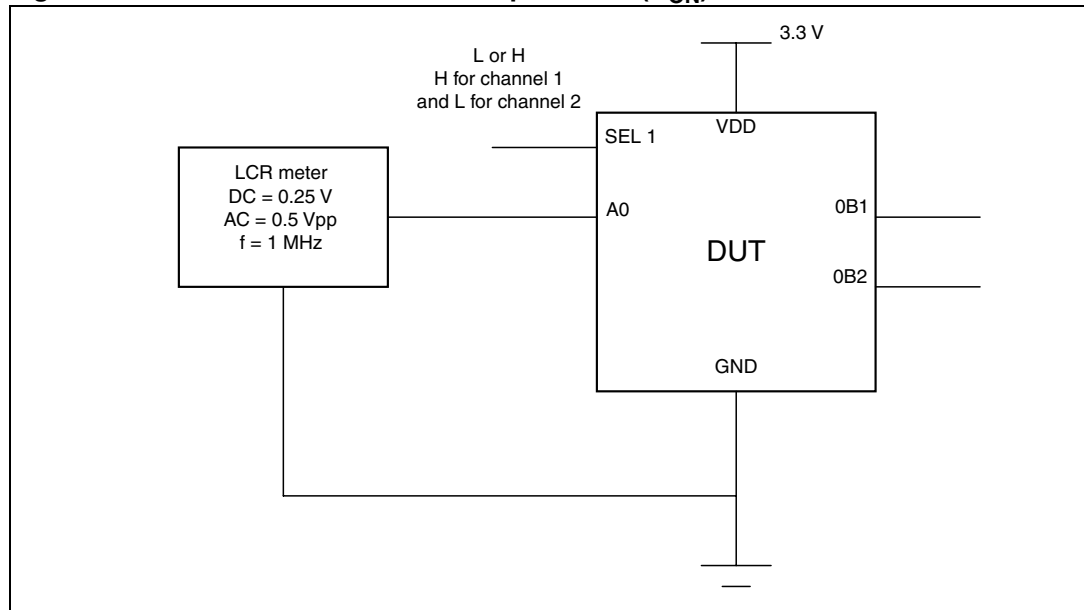
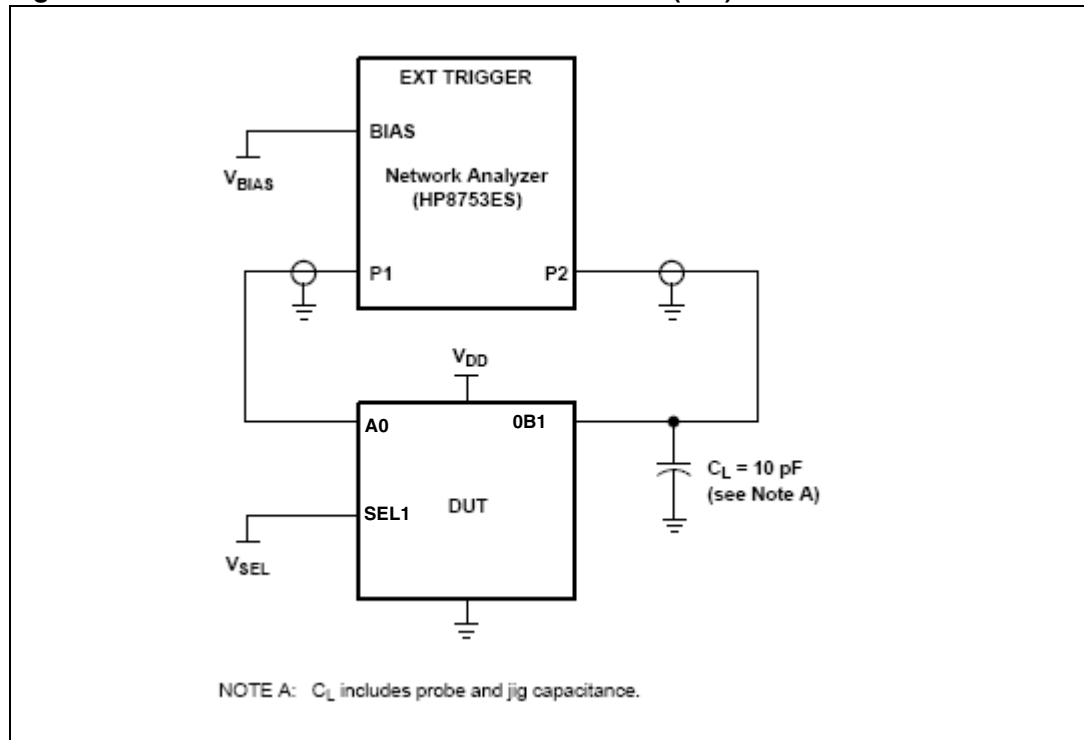

Figure 8. Test circuit for bandwidth measurement (BW)



Frequency response is measured at the output of the ON channel. For example, when $V_{SEL1} = 0$ and A0 is the input, the output is measured at OB1. All unused analog I/O ports are left open.

HP8753ES setup:

Average = 4

$R_{BW} = 3 \text{ kHz}$
 $V_{BIAS} = 0.35 \text{ V}$
 $ST = 2 \text{ s}$
 $P1 = 0 \text{ dBm}$

Figure 9. Test circuit for crosstalk measurement (x_{talk})

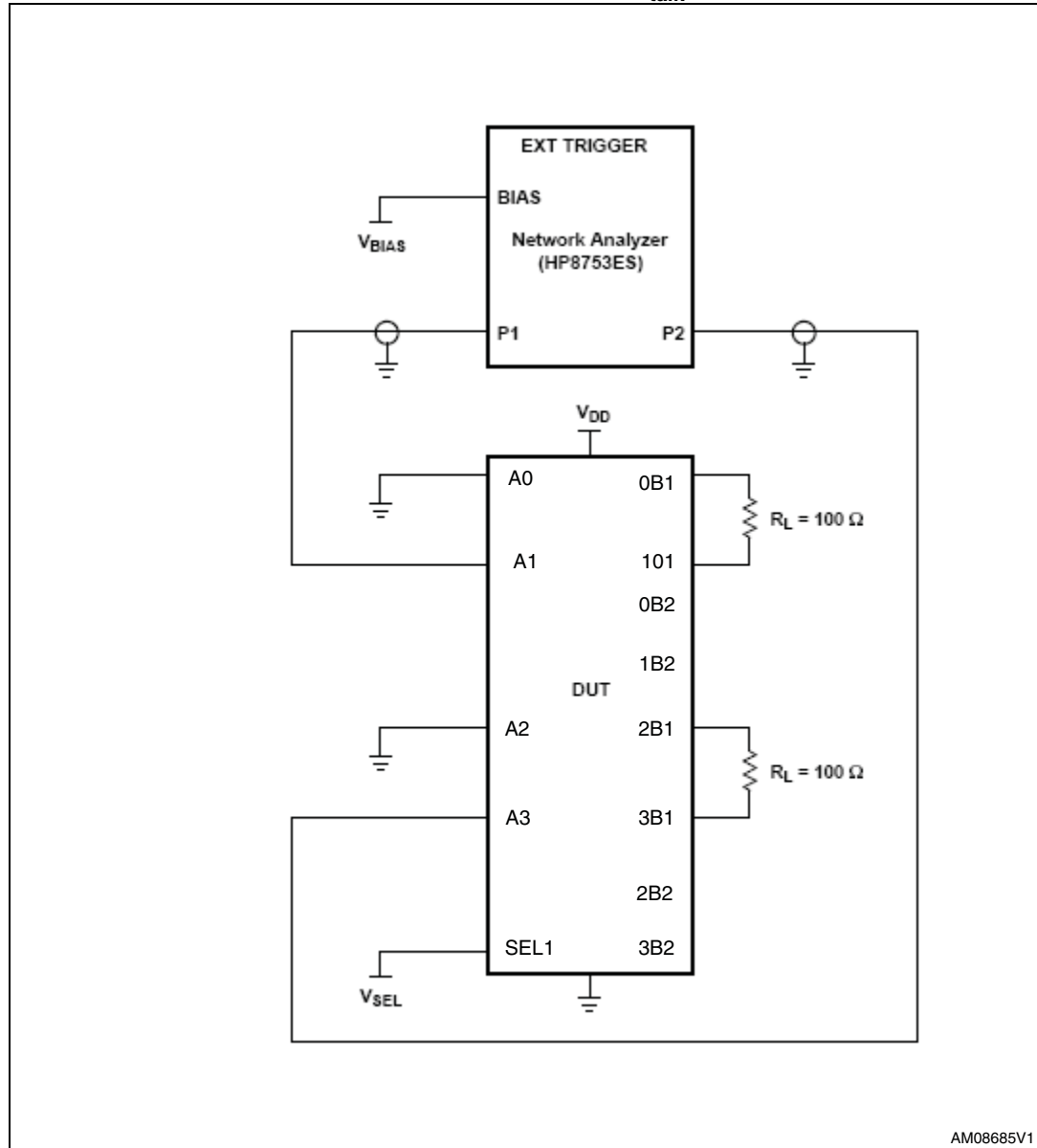

Crosstalk is measured at the output of the non-adjacent ON channel. For example, when $V_{SEL1} = 0$, and A1 is the input, the output is measured at A3. All unused analog input ports are connected to GND and output ports are left open.

HP8753ES setup:

Average = 4

$R_{BW} = 3 \text{ kHz}$
 $V_{BIAS} = 0.35 \text{ V}$
 $ST = 2 \text{ s}$
 $P1 = 0 \text{ dBm}$

Figure 10. Test circuit for off isolation measurement (O_{IRR})

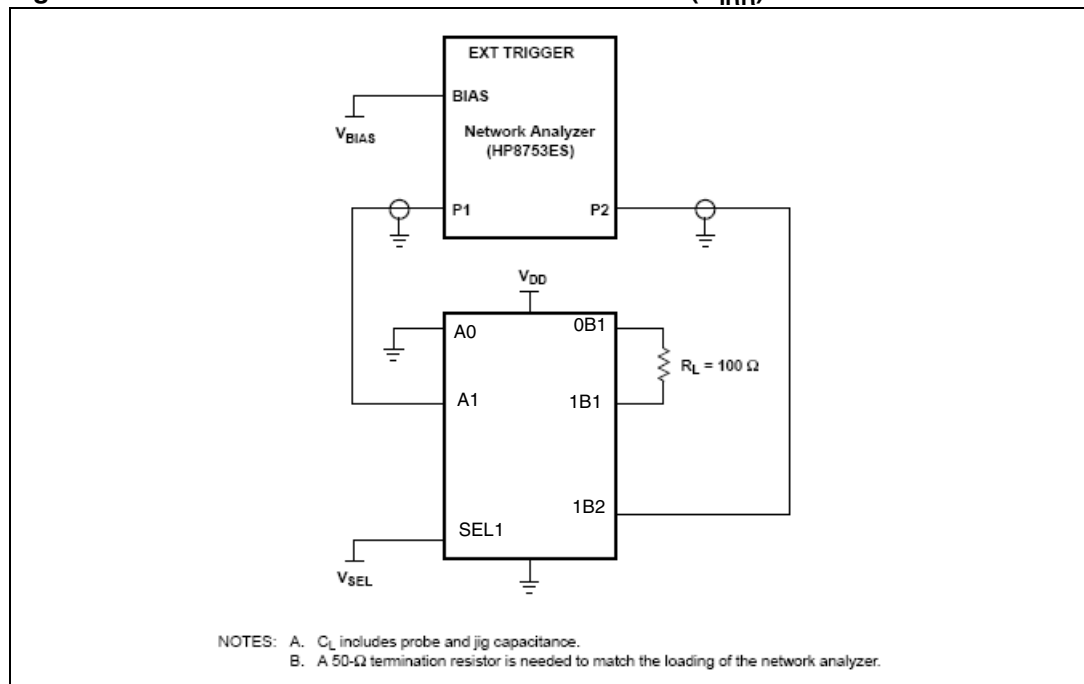

Off isolation is measured at the output of the OFF channel. For example, when $V_{SEL1} = 0$, and A1 is the input, the output is measured at 1B2. All unused analog input ports are connected to GND and output ports are left open.

HP8753ES setup:

Average = 4
 $R_{BW} = 3 \text{ kHz}$
 $V_{BIAS} = 0.35 \text{ V}$
 $ST = 2 \text{ s}$
 $P1 = 0 \text{ dBm}$

4 Package mechanical data

In order to meet environmental requirements, ST offers these devices in different grades of ECOPACK® packages, depending on their level of environmental compliance. ECOPACK® specifications, grade definitions and product status are available at: www.st.com. ECOPACK® is an ST trademark.

Figure 11. Package outline for QFN32L (3 x 6 x 0.8 mm) - pitch 0.4 mm

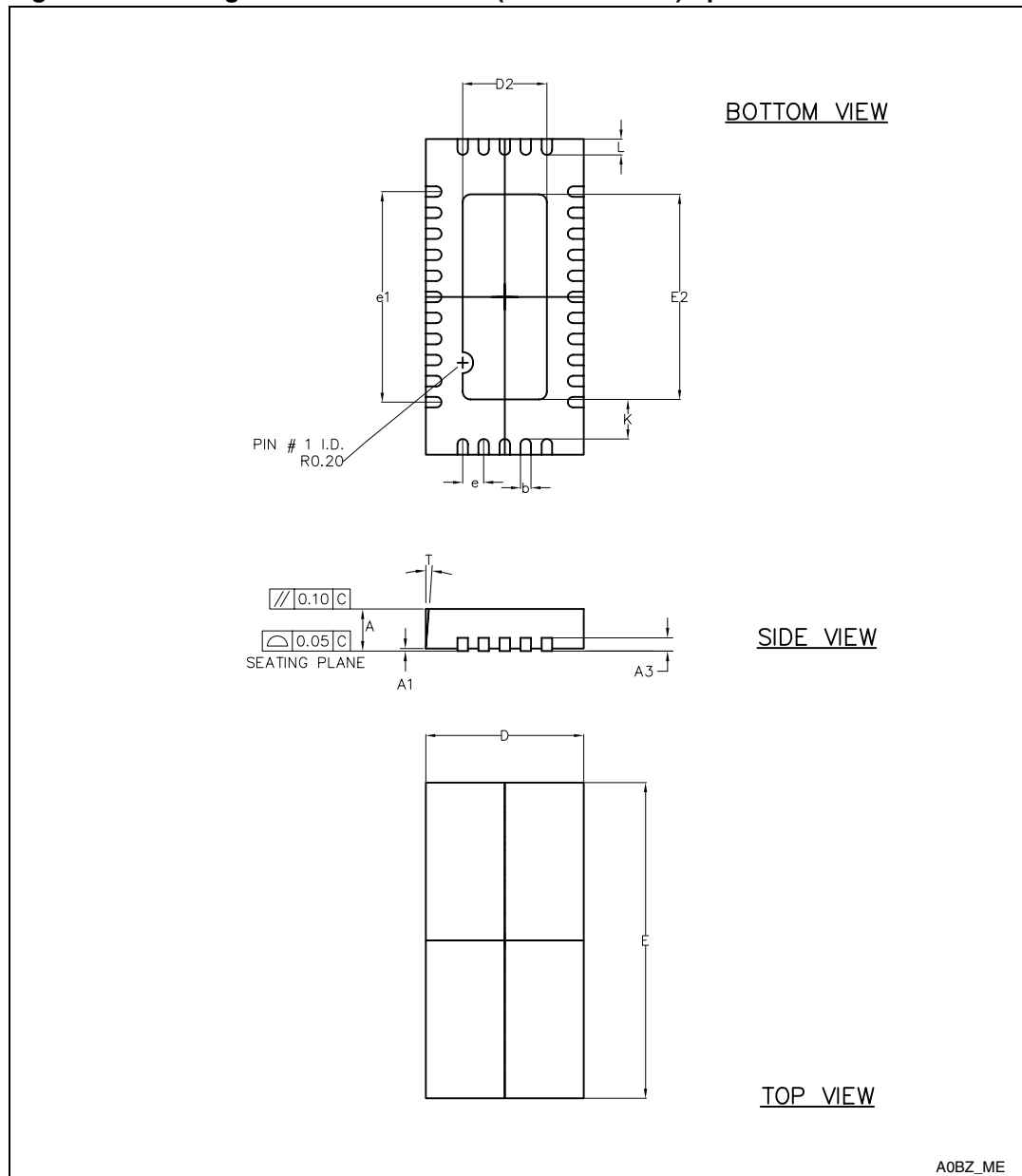

Table 13. Mechanical data for QFN32L (3 x 6 x 0.8 mm) - pitch 0.4 mm

Symbol	Millimeters		
	Min	Typ	Max
A	0.70	0.80	0.90
A1	0.00	0.05	0.08
A3		0.25	
T	0.00		12.00
b	0.15	0.20	0.25
e		0.40	
e1		4.00	
K		0.75	
D		3.00	
E		6.00	
L	0.25	0.30	0.35
D2	1.50	1.60	1.79
E2	3.80	3.90	4.00

Figure 12. Footprint recommendation

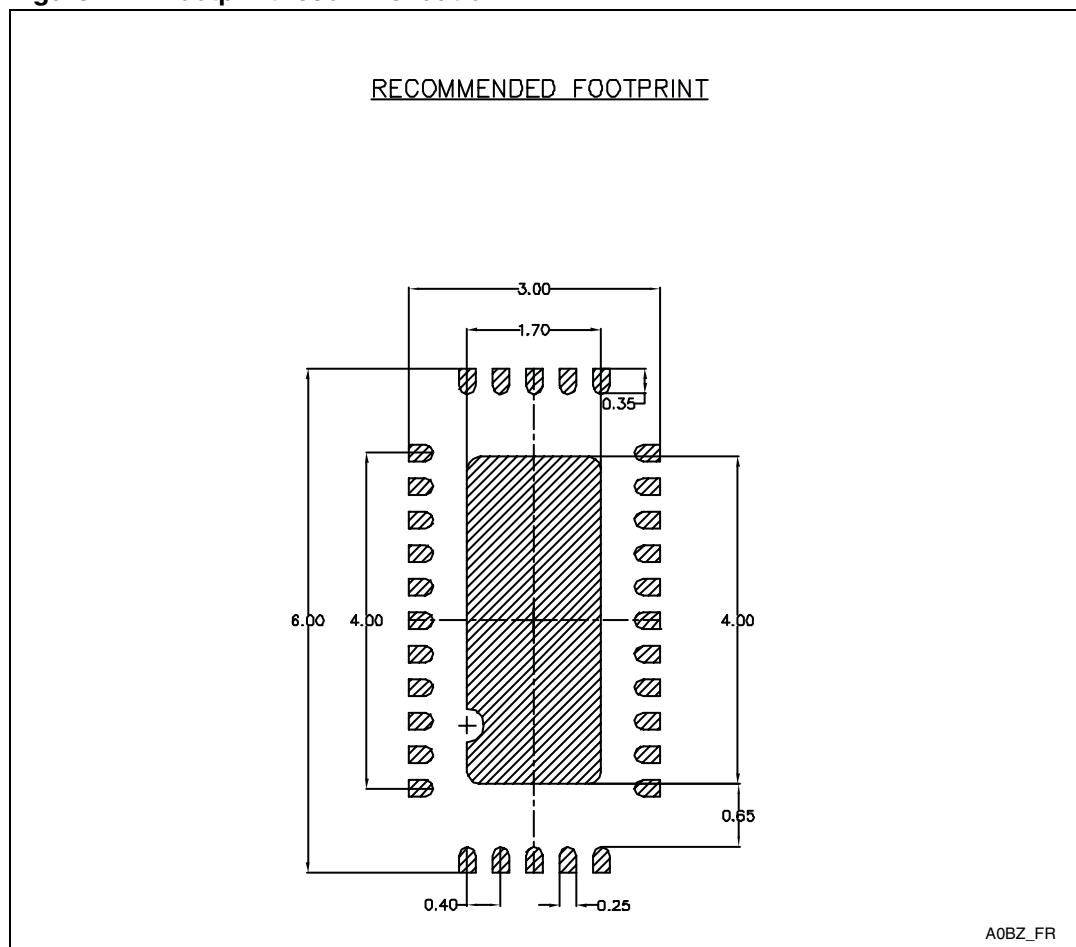
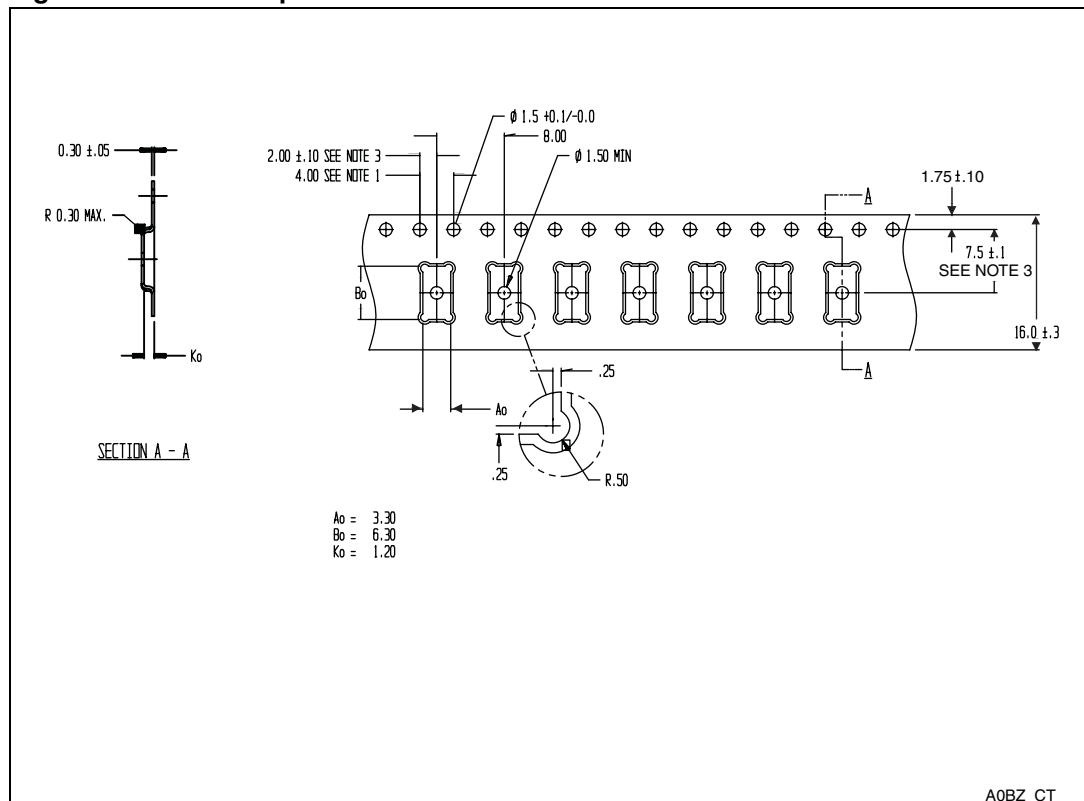

Figure 13. Carrier tape and reel information



5 Revision history

Table 14. Document revision history

Date	Revision	Changes
23-Apr-2010	1	Initial release.
16-Jun-2010	2	Modified: Figure 12 .
09-Mar-2011	3	Updated: Table 8 , Table 11 and Table 12 .

Please Read Carefully:

Information in this document is provided solely in connection with ST products. STMicroelectronics NV and its subsidiaries ("ST") reserve the right to make changes, corrections, modifications or improvements, to this document, and the products and services described herein at any time, without notice.

All ST products are sold pursuant to ST's terms and conditions of sale.

Purchasers are solely responsible for the choice, selection and use of the ST products and services described herein, and ST assumes no liability whatsoever relating to the choice, selection or use of the ST products and services described herein.

No license, express or implied, by estoppel or otherwise, to any intellectual property rights is granted under this document. If any part of this document refers to any third party products or services it shall not be deemed a license grant by ST for the use of such third party products or services, or any intellectual property contained therein or considered as a warranty covering the use in any manner whatsoever of such third party products or services or any intellectual property contained therein.

UNLESS OTHERWISE SET FORTH IN ST'S TERMS AND CONDITIONS OF SALE ST DISCLAIMS ANY EXPRESS OR IMPLIED WARRANTY WITH RESPECT TO THE USE AND/OR SALE OF ST PRODUCTS INCLUDING WITHOUT LIMITATION IMPLIED WARRANTIES OF MERCHANTABILITY, FITNESS FOR A PARTICULAR PURPOSE (AND THEIR EQUIVALENTS UNDER THE LAWS OF ANY JURISDICTION), OR INFRINGEMENT OF ANY PATENT, COPYRIGHT OR OTHER INTELLECTUAL PROPERTY RIGHT.

UNLESS EXPRESSLY APPROVED IN WRITING BY AN AUTHORIZED ST REPRESENTATIVE, ST PRODUCTS ARE NOT RECOMMENDED, AUTHORIZED OR WARRANTED FOR USE IN MILITARY, AIR CRAFT, SPACE, LIFE SAVING, OR LIFE SUSTAINING APPLICATIONS, NOR IN PRODUCTS OR SYSTEMS WHERE FAILURE OR MALFUNCTION MAY RESULT IN PERSONAL INJURY, DEATH, OR SEVERE PROPERTY OR ENVIRONMENTAL DAMAGE. ST PRODUCTS WHICH ARE NOT SPECIFIED AS "AUTOMOTIVE GRADE" MAY ONLY BE USED IN AUTOMOTIVE APPLICATIONS AT USER'S OWN RISK.

Resale of ST products with provisions different from the statements and/or technical features set forth in this document shall immediately void any warranty granted by ST for the ST product or service described herein and shall not create or extend in any manner whatsoever, any liability of ST.

ST and the ST logo are trademarks or registered trademarks of ST in various countries.

Information in this document supersedes and replaces all information previously supplied.

The ST logo is a registered trademark of STMicroelectronics. All other names are the property of their respective owners.

© 2011 STMicroelectronics - All rights reserved

STMicroelectronics group of companies

Australia - Belgium - Brazil - Canada - China - Czech Republic - Finland - France - Germany - Hong Kong - India - Israel - Italy - Japan - Malaysia - Malta - Morocco - Philippines - Singapore - Spain - Sweden - Switzerland - United Kingdom - United States of America

www.st.com