



Chipsmall Limited consists of a professional team with an average of over 10 year of expertise in the distribution of electronic components. Based in Hongkong, we have already established firm and mutual-benefit business relationships with customers from,Europe,America and south Asia,supplying obsolete and hard-to-find components to meet their specific needs.

With the principle of “Quality Parts,Customers Priority,Honest Operation,and Considerate Service”,our business mainly focus on the distribution of electronic components. Line cards we deal with include Microchip,ALPS,ROHM,Xilinx,Pulse,ON,Everlight and Freescale. Main products comprise IC,Modules,Potentiometer,IC Socket,Relay,Connector.Our parts cover such applications as commercial,industrial, and automotives areas.

We are looking forward to setting up business relationship with you and hope to provide you with the best service and solution. Let us make a better world for our industry!



Contact us

Tel: +86-755-8981 8866 Fax: +86-755-8427 6832

Email & Skype: info@chipsmall.com Web: www.chipsmall.com

Address: A1208, Overseas Decoration Building, #122 Zhenhua RD., Futian, Shenzhen, China





STP04CM596

4-Bit constant current for power-LED LED sink driver

General features

- 4 constant current output channels
- Adjustable output current through one external resistor
- Serial data IN/parallel data OUT
- Serial OUT change state on the falling edges of clock
- Four outputs current: 80-500mA
- 25MHz clock frequency
- Available in high thermal TSSOP exposed pad.

Description

The STP04CM596 is a high-power LED Driver and 4-bit shift register designed for PowerLED applications.

The STP04CM596 contains a 4-bit serial IN, parallel OUT shift register that feeds a 4-bit D-type storage register. In the output stage, four regulated current sources were designed to provide 80-500mA constant current to drive the high powered LEDs.

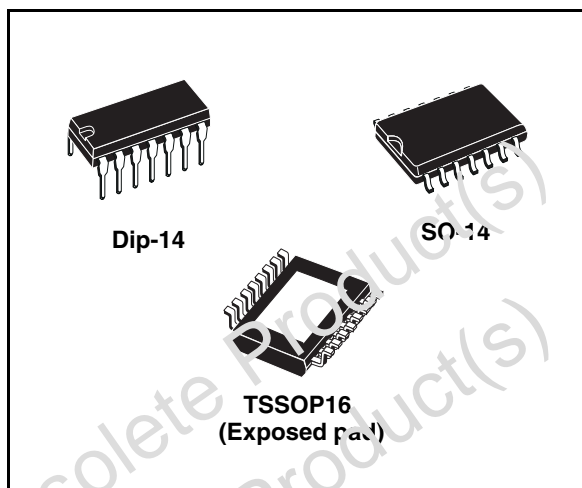

The STP04CM596 guarantees 16V output driving capability, allowing users to connect more LEDs in series. The high clock frequency, 25 MHz, also satisfies the system requirements which include high volume data transmission.

The STP04CM596 is well suited for very high brightness displays and special lighting applications.

The STP04CM596 is offered in DIP-14, SO-14 and TSSOP16 Exposed Pad packages.

Order codes

Part Number	Package	Packaging
STP04CM596B1R	DIP-14	25 parts per tube
STP04CM596M	SO-14 (Tube)	50 parts per tube
STP04CM596MTR	SO-14 (Tape & Reel)	2500 parts per reel
STP04CM596XTTR	TSSOP16 Exposed-pad (Tape & Reel)	2500 parts per reel

Contents

1	Internal schematic	3
2	Pin settings	4
2.1	Pin connection	4
2.2	Pin description	4
3	Maximum rating	5
3.1	Thermal data	5
3.2	Recommended operating conditions	6
4	Electrical characteristics	7
5	Equivalent circuit of inputs and outputs	9
6	Timing diagrams	11
7	Test circuit	14
8	Typical characteristics	15
9	Package mechanical data	17
10	Revision history	23

1 Internal schematic

Figure 1. Block diagram

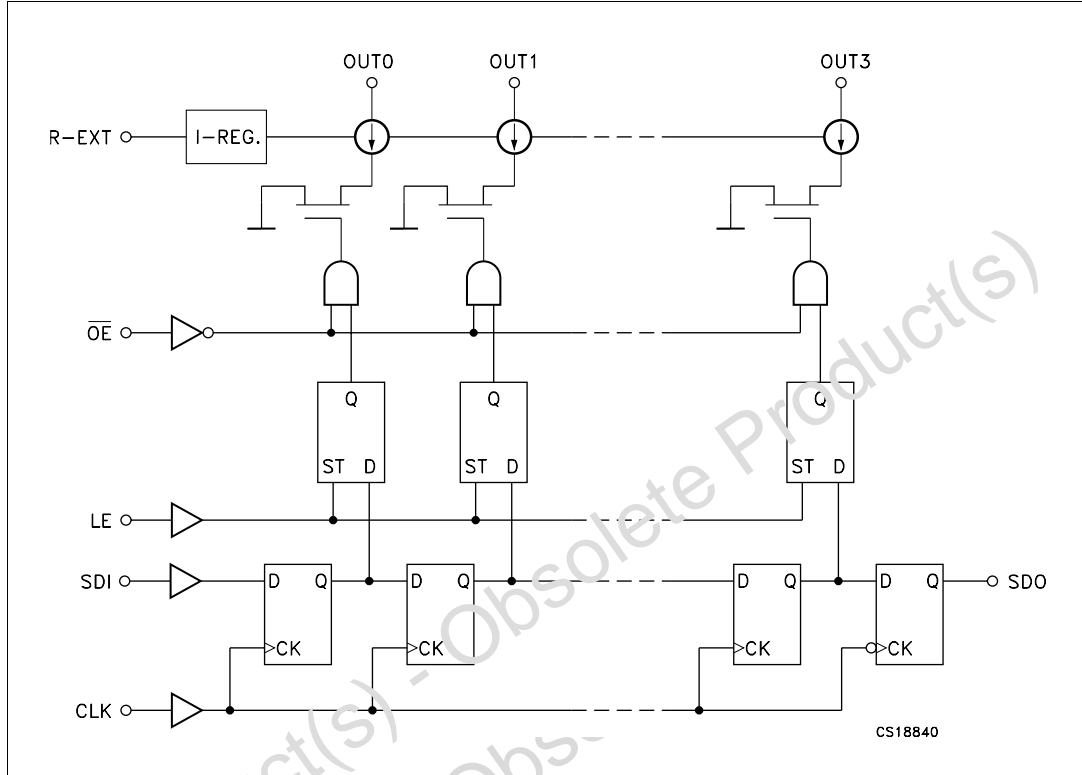

Obsolete Product(s) - Obsolete Product(s)
Obsolete Product(s) - Obsolete Product(s)

2 Pin settings

2.1 Pin connection

Figure 2. Pin connection

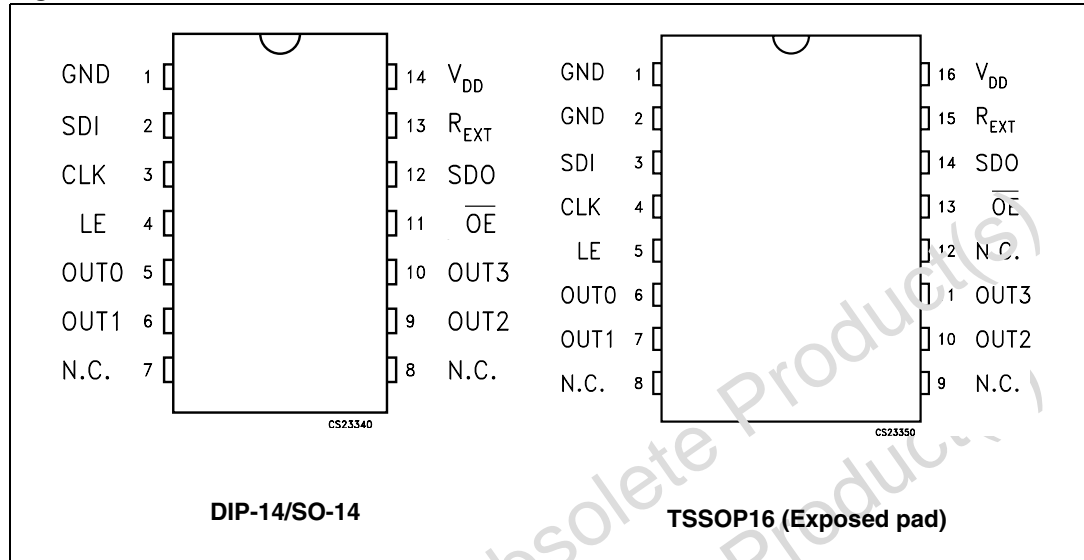

2.2 Pin description

Table 1. Pin description

DIP-14 and SO-14 Pin N°	TSSOP16 Pin N°	Symbol	Name and function
	1, 2	GND	Ground terminal
2	3	SDI	Serial data input terminal
3	4	CLK	Clock input terminal
4	5	LE	Latch input terminal
5	6	OUT 0	Output terminal
6	7	OUT 1	Output terminal
7, 8	8, 9, 12	N.C.	Not connected
9	10	OUT 2	Output terminal
10	11	OUT 3	Output terminal
11	13	\overline{OE}	Output enable input terminal (active low)
12	14	SDO	Serial data out terminal
13	15	R-EXT	Constant current programming
14	16	V_{DD}	5V supply voltage terminal

3 Maximum rating

Stressing the device above the rating listed in the “Absolute Maximum Ratings” table may cause permanent damage to the device. These are stress ratings only and operation of the device at these or any other conditions above those indicated in the Operating sections of this specification is not implied. Exposure to Absolute Maximum Rating conditions for extended periods may affect device reliability. Refer also to the STMicroelectronics SURE Program and other relevant quality documents.

Table 2. Absolute maximum ratings

Symbol	Parameter	Value	Unit
V_{DD}	Supply voltage	0 to 7	V
V_O	Output voltage	-0.5 to 16	V
I_O	Output current	500	mA
V_I	Input voltage	-0.4 to $V_{DD}+0.4$	V
I_{GND}	GND terminal current	2000	mA
f_{CLK}	Clock frequency	25	MHz
T_{OPR}	Operating temperature range	-40 to +125	°C
T_{STG}	Storage temperature range	-55 to +150	°C

3.1 Thermal data

Table 3. Thermal data

Symbol	Parameter	DIP-14	SO-14	TSSOP16	Unit
$R_{th(j-a)}$	Thermal resistance junction-ambient	70 ⁽¹⁾	105 ⁽²⁾	37.5 ⁽³⁾	°C/W

1. 1V of dissipated power, mounted on the board
2. 1W of dissipated power, mounted on SM PCB1 SGS board
3. Using the PCB Multi-Layer JEDEC Standard Test Boards

3.2 Recommended operating conditions

Table 4. Recommended operating conditions

Symbol	Parameter	Test conditions	Min	Typ	Max	Unit
V_{DD}	Supply voltage		3.3	5.0	5.5	V
V_O	Output voltage				16.0	V
I_O	Output current	OUTn $V_{DD} = 5V$	80		500	mA
I_{OH}	Output current	Serial-OUT			+1	mA
I_{OL}	Output current	Serial-OUT			-1	mA
V_{IH}	Input voltage		$0.7V_{DD}$		$V_{DD}+0.5$	V
V_{IL}	Input voltage		-0.3		$0.3V_{DD}$	V
t_{wLAT}	LE pulse width		20	6.5		ns
t_{wCLK}	CLK pulse width		20	7.0		ns
t_{wEN}	\overline{OE} pulse width		400	100		ns
$t_{SETUP(D)}$	Setup time for DATA	$V_{DD} = 3.0$ to $3.6V$	20	3.3		ns
$t_{HOLD(D)}$	Hold time for DATA		15	1.5		ns
$t_{SETUP(L)}$	Setup time for LATCH		15	5		ns
$t_{HOLD(E)}$	Hold time for ENABLE		60	38		ns
f_{CLK}	Clock frequency	Cascade operation ⁽¹⁾			25	MHz
T_{OPR}	Operating temperature range		-40		+125	°C

1. If multiple devices are cascaded, it may not be possible to achieve the maximum data transfer. Please consider the timing conditions carefully.

4 Electrical characteristics

Table 5. Current accuracy

Output voltage	Current accuracy		Output current
	Between bits	Between ICs	
$\geq 0.7V$	Typ. $\pm 1\%$	$\pm 6\%$	80 to 500 mA

Table 6. Electrical characteristics ($V_{DD} = 5V$, $T_A = 25^\circ C$, unless otherwise specified.)

Symbol	Parameter	Test conditions	Min	Typ	Max	Unit
V_{IH}	Input voltage high level		$0.7V_{DD}$		V_{DD}	V
V_{IL}	Input voltage low level		GND		$0.3V_{DD}$	V
I_{OH}	Output leakage current	$V_{OH} = 16V$			10	μA
V_{OL}	Output voltage (Serial-OUT)	$I_{OL} = 1mA$			0.4	V
V_{OH}	Output voltage (Serial-OUT)	$I_{OH} = -1mA$	$V_{DD}-0.4V$			V
I_{OL1}	Output current	$V_O = 0.7V_{DD}$, $R_{EXT} = 910\ \Omega$	77	82	87	mA
I_{OL2}		$V_O = 0.7V_{DD}$, $R_{EXT} = 160\ \Omega$	470	500	530	mA
ΔI_{OL1}	Output current error between bit (All Output ON)	$V_O = 0.7V_{DD}$, $R_{EXT} = 910\ \Omega$		1	± 3	%
ΔI_{OL2}		$V_O = 0.7V_{DD}$, $R_{EXT} = 160\ \Omega$		0.5	± 3	%
$R_{SIN(up)}$	Pull-up resistor		150	300	600	K Ω
$R_{SIN(down)}$	Pull-down resistor		100	200	400	K Ω
$I_{DD(OFF1)}$	Supply current (OFF)	$R_{EXT} = OPEN$ OUT 0 to 3 = OFF		0.3	0.6	mA
$I_{DD(OFF2)}$		$R_{EXT} = 470\ \Omega$ OUT 0 to 3 = OFF		5.2	8.0	
$I_{DD(OFF3)}$		$R_{EXT} = 250\ \Omega$ OUT 0 to 3 = OFF		8.0	12	
$I_{DD(ON1)}$	Supply current (ON)	$R_{EXT} = 470\ \Omega$ OUT 0 to 3 = ON		5.6	8.0	
$I_{DD(ON2)}$		$R_{EXT} = 250\ \Omega$ OUT 0 to 3 = ON		8.3	12	

Table 7. Switching characteristics ($V_{DD}=5V$, $T = 25^{\circ}C$, unless otherwise specified.)

Symbol	Parameter	Test conditions	Min	Typ	Max	Unit	
t_{PLH1}	Propagation delay time, $\overline{CLK}-\overline{OUTn}$, $LE = H$, $\overline{OE} = L$	$V_{DD} = 5V$ $V_{IH} = V_{DD}$ $V_{IL} = GND$ $C_L = 13pF$ $I_O = 40mA$ $V_L = 3V$ $R_{EXT} = 470\Omega$ $R_L = 65\Omega$		100	160	ns	
t_{PLH2}	Propagation delay time, $\overline{LE}-\overline{OUTn}$, $\overline{OE} = L$			100	150	ns	
t_{PLH3}	Propagation delay time, $\overline{OE}-\overline{OUTn}$, $LE = H$			90	140	ns	
t_{PLH}	Propagation delay time, $\overline{CLK}-\overline{SDO}$				30	40	ns
t_{PHL1}	Propagation delay time, $\overline{CLK}-\overline{OUTn}$, $LE = H$, $\overline{OE} = L$				40	60	ns
t_{PHL2}	Propagation delay time, $\overline{LE}-\overline{OUTn}$, $\overline{OE} = L$				35	50	ns
t_{PHL3}	Propagation delay time, $\overline{OE}-\overline{OUTn}$, $LE = H$				40	70	ns
t_{PHL}	Propagation delay time, $\overline{CLK}-\overline{SDO}$				30	40	ns
t_r	Output rise time ⁽¹⁾		$V_O = 1.6V$, $R_L = 1\Omega$		300	400	ns
t_f	Output fall time ⁽¹⁾	$R_{EXT} = 470\Omega$		55	80	ns	

1. If multiple devices are cascaded, it may not be possible to achieve the maximum data transfer. Please consider the timing conditions carefully.

5 Equivalent circuit of inputs and outputs

Figure 3. \overline{OE} terminal

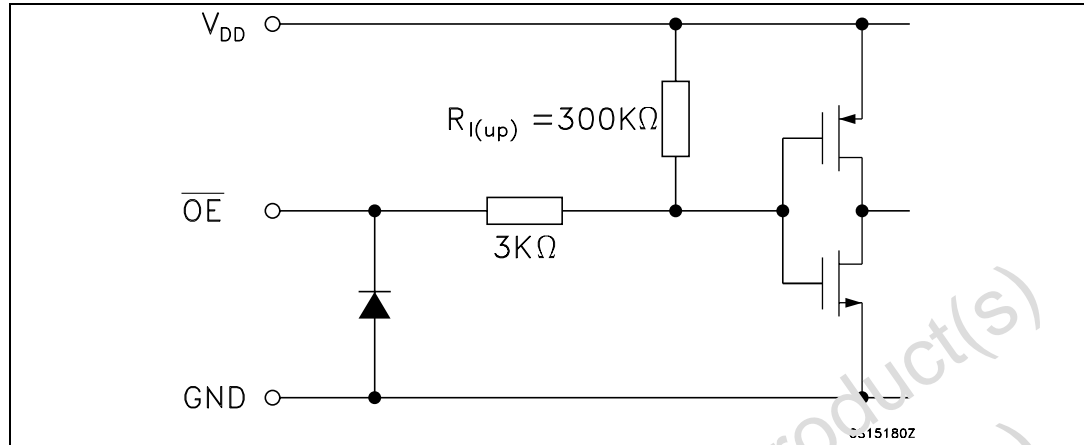

Figure 4. LE terminal

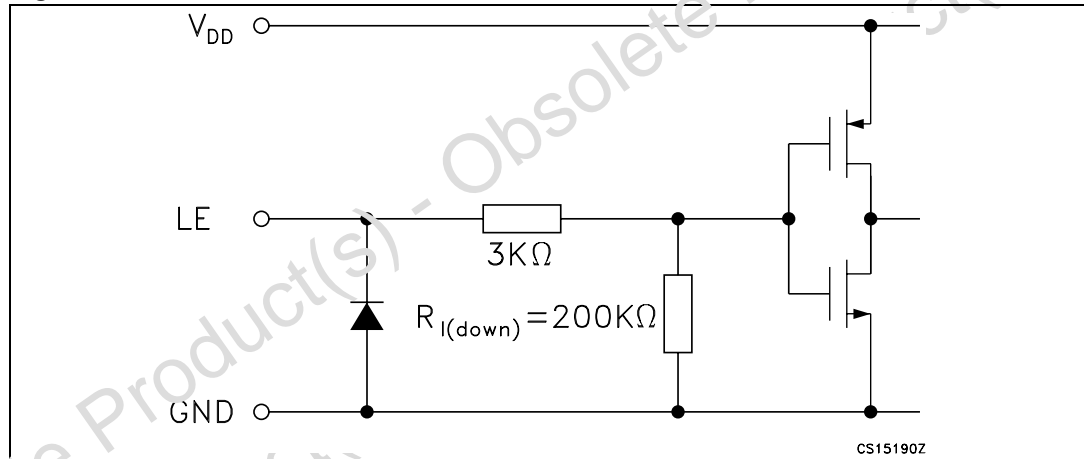

Figure 5. CLK, SDI terminal

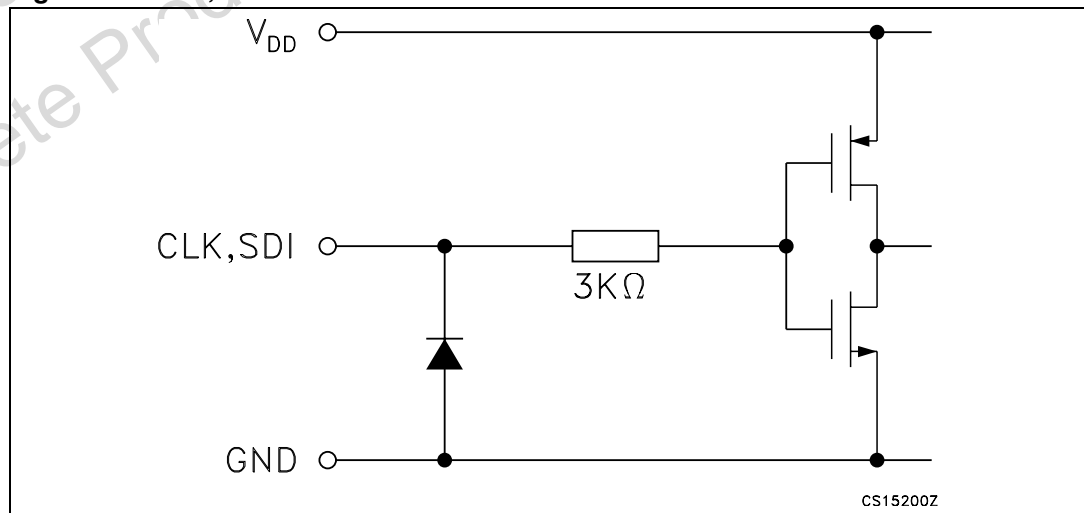
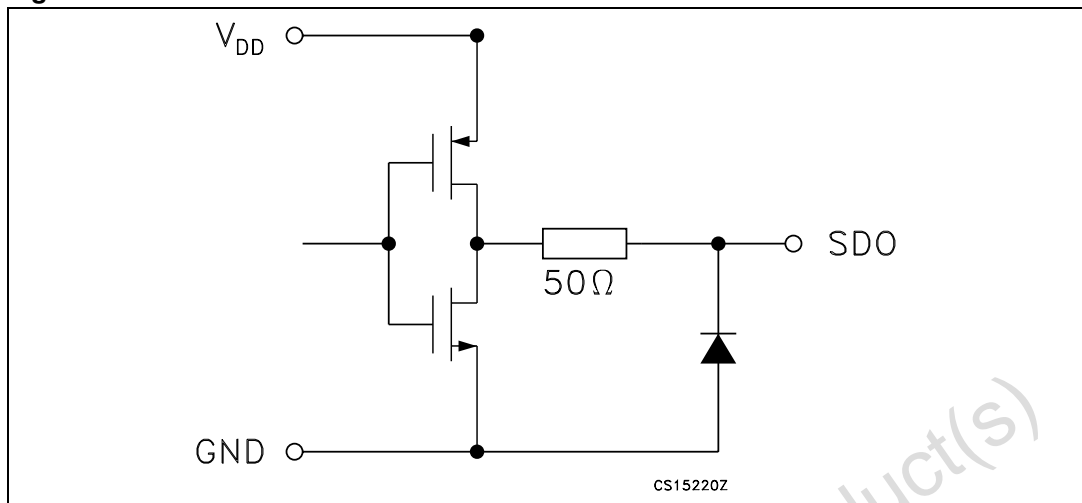

Figure 6. SDO terminal



Obsolete Product(s) - Obsolete Product(s)
Obsolete Product(s) - Obsolete Product(s)

6 Timing diagrams

Figure 7. Timing diagram

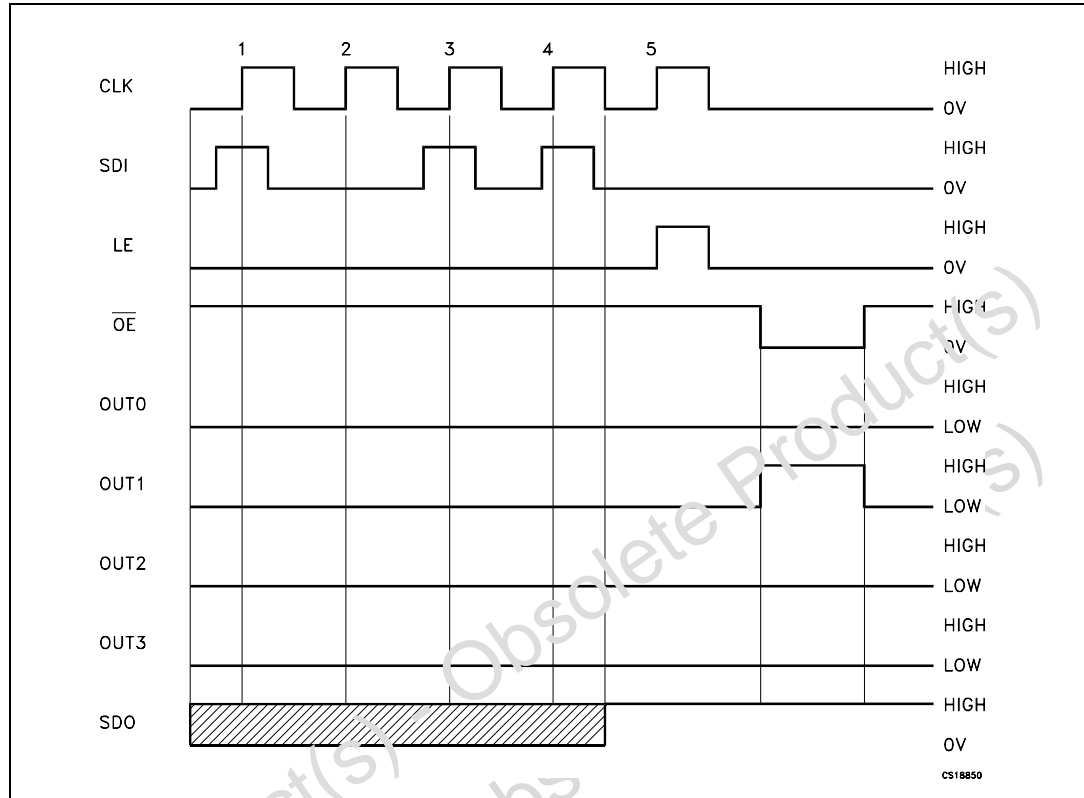

Note: The latches circuit holds data when the LE terminal is Low.

- 1 When the LE terminal is at a High level, the latch circuit holds the data it passes from the input to the output.
- 2 When the \overline{OE} terminal is at a Low level, the output terminals OUT0 to OUT3 respond to the data, either ON or OFF.
- 3 When the \overline{OE} terminal is at a High level, it switches off all the data on the output terminal.

Figure 8. Clock, serial-IN, serial-OUT

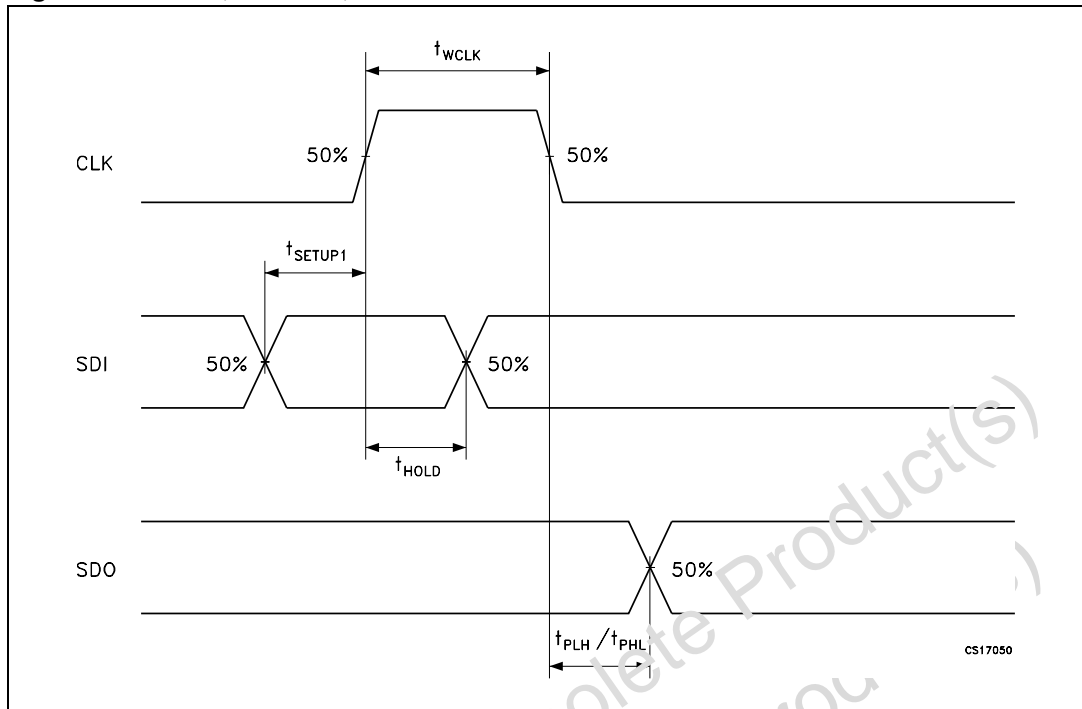

Figure 9. Clock, serial-IN, latch, enable, outputs

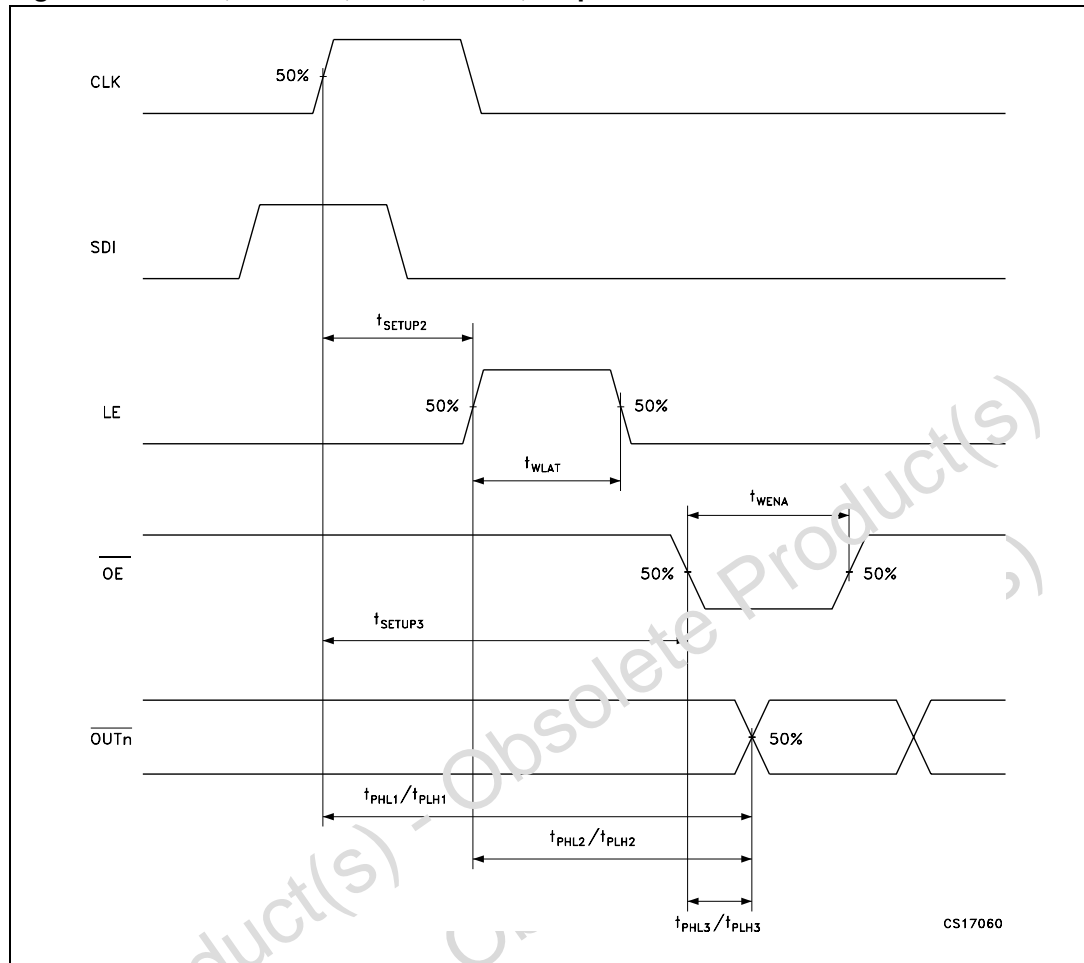
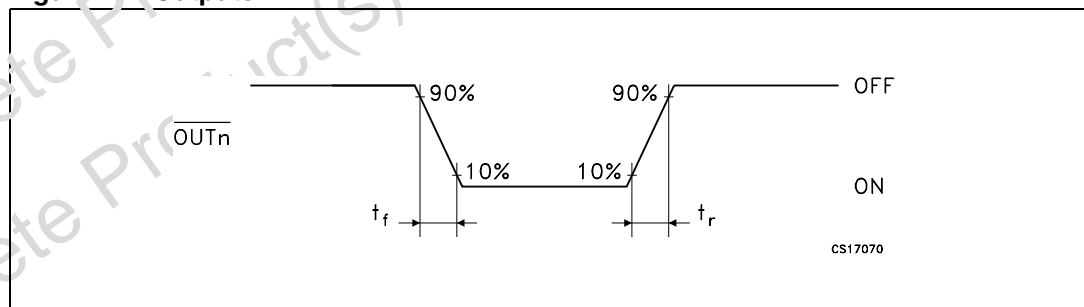

Figure 10. Outputs



7 Test circuit

Figure 11. DC characteristic

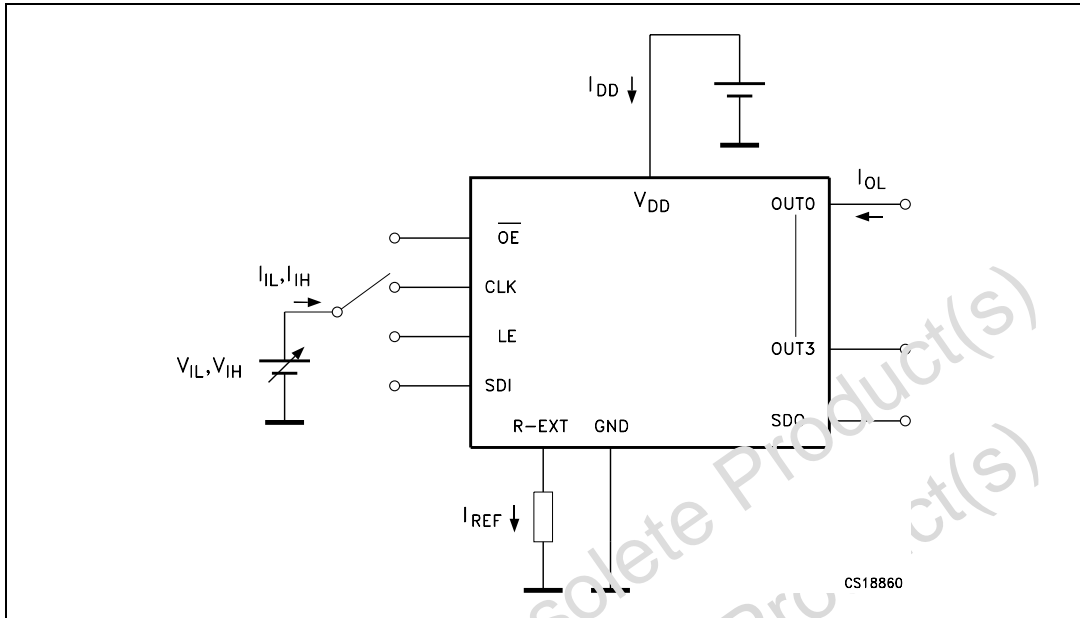
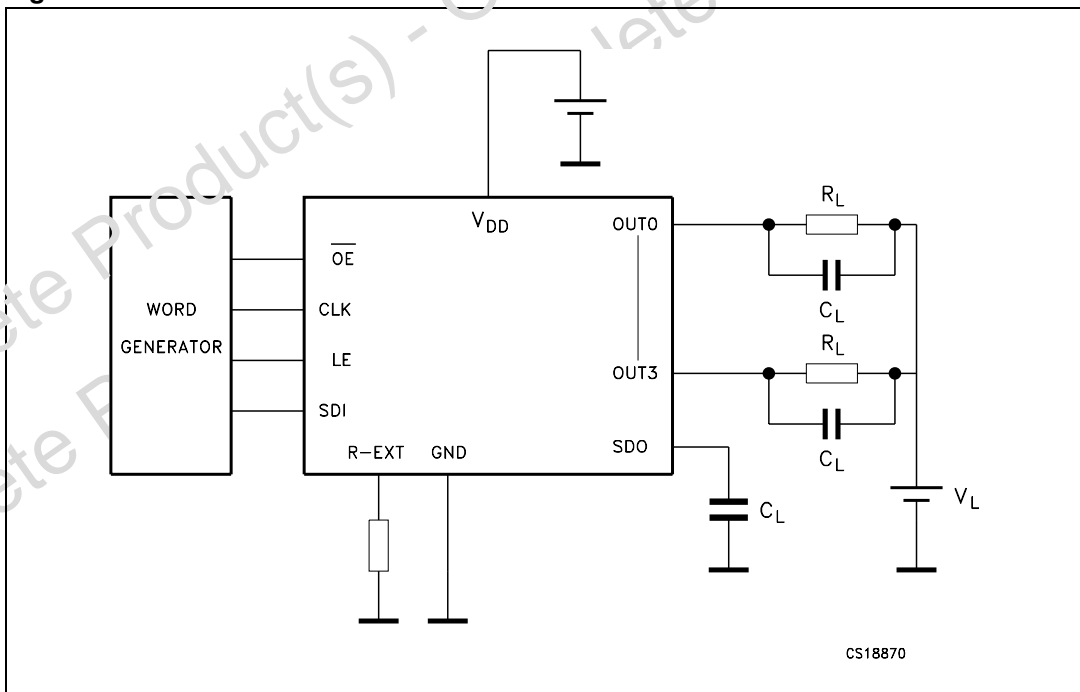

Figure 12. AC characteristic



8 Typical characteristics

Figure 13. Output current- R_{EXT} resistor

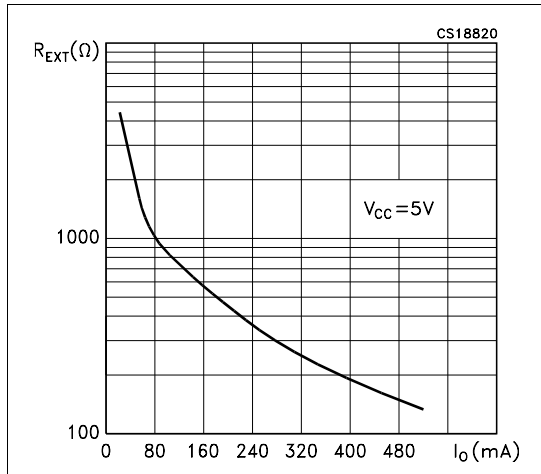

Figure 14. Output current vs dropout voltage

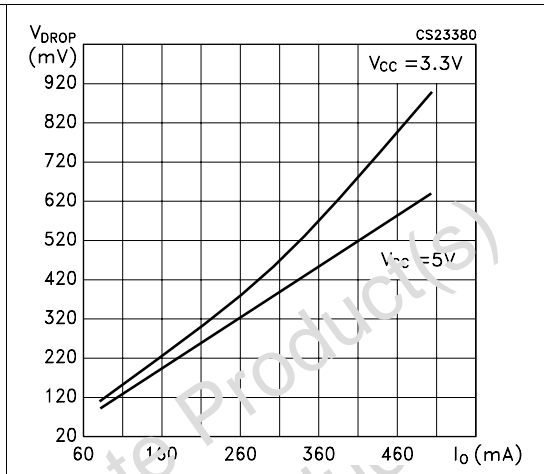

Figure 15. Output current vs $\pm\Delta I_{OL}$ (%)

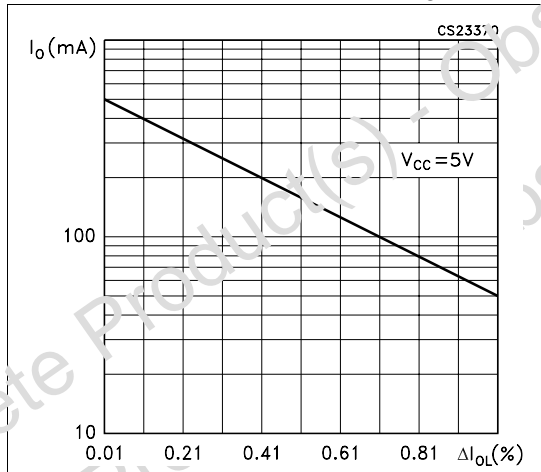
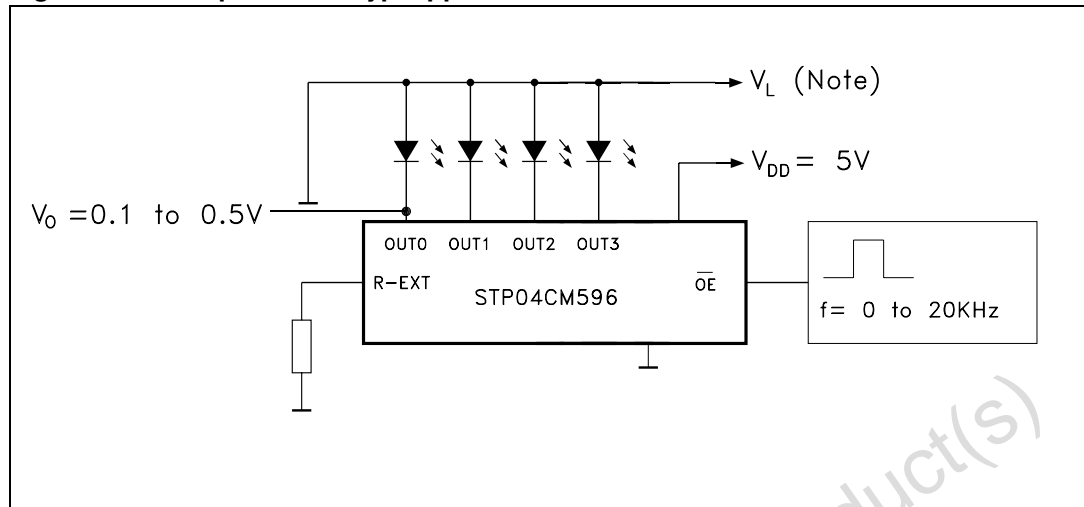
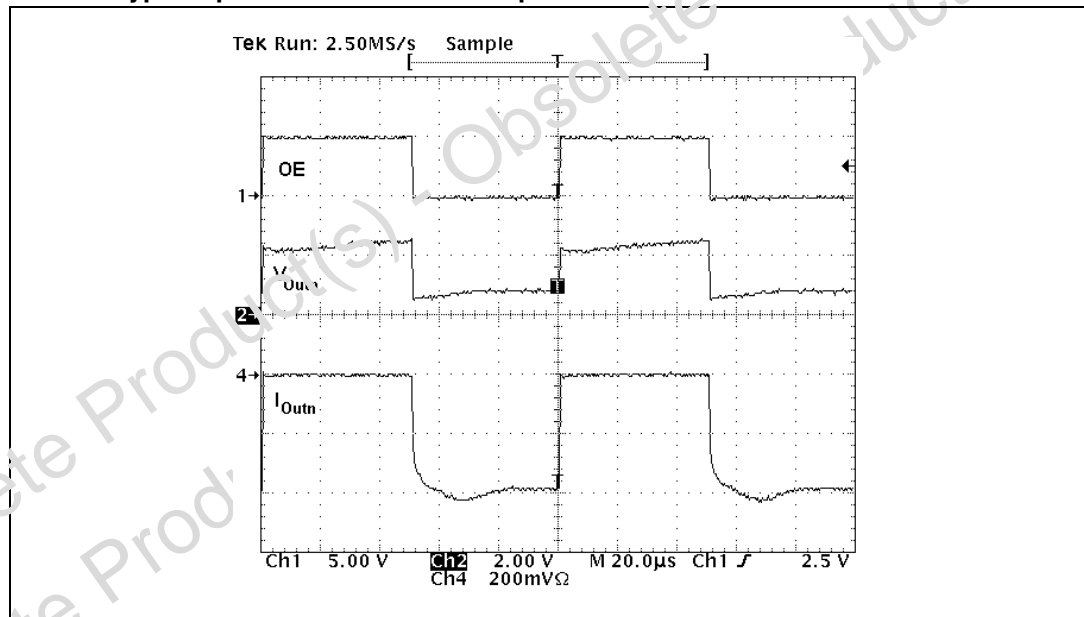

Figure 16. Blue powerLED typ. application circuit



Note: V_L will be determined by the V_F of the LEDs

Table 8. Typ. output waveform with blue powerLEDs



9 Package mechanical data

In order to meet environmental requirements, ST offers these devices in ECOPACK® packages. These packages have a Lead-free second level interconnect . The category of second level interconnect is marked on the package and on the inner box label, in compliance with JEDEC Standard JESD97. The maximum ratings related to soldering conditions are also marked on the inner box label. ECOPACK is an ST trademark. ECOPACK specifications are available at: www.st.com

Obsolete Product(s) - Obsolete Product(s)
Obsolete Product(s) - Obsolete Product(s)

Table 9. DIP-14 mechanical data

Dim.	mm.			inch		
	Min	Typ	Max	Min	Typ	Max
a1	0.51			0.020		
B	1.39		1.65	0.055		0.065
b		0.5			0.020	
b1		0.25			0.010	
D			20			0.787
E		8.5			0.335	
e		2.54			0.100	
e3		15.24			0.600	
F			7.1			0.280
I			5.1			0.201
L		3.3			0.130	
Z	1.27		2.54	0.050		0.100

Figure 17. Package dimensions

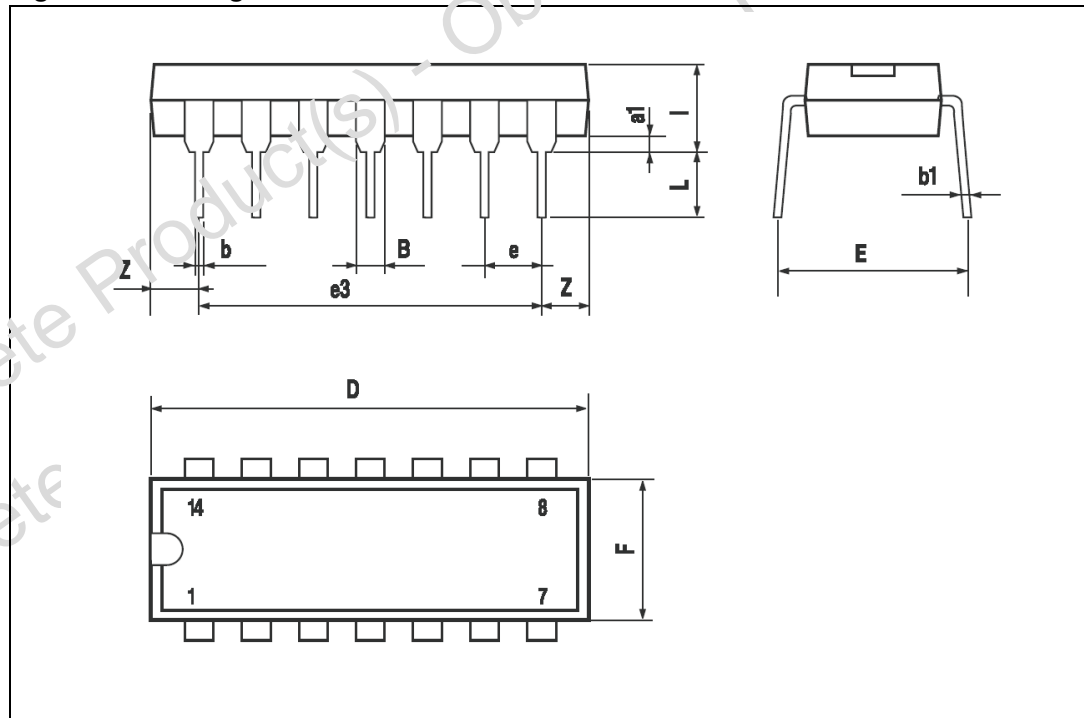

Table 10. SO-14 mechanical data

Dim.	mm.			inch		
	Min	Typ	Max	Min	Typ	Max
A			1.75			0.068
a1	0.1		0.2	0.003		0.007
a2			1.65			0.064
b	0.35		0.46	0.013		0.018
b1	0.19		0.25	0.007		0.010
C		0.5			0.019	
c1	45° (typ.)					
D	8.55		8.75	0.336		0.344
E	5.8		6.2	0.228		0.244
e		1.27			0.050	
e3		7.62			0.300	
F	3.8		4.0	0.149		0.157
G	4.6		5.3	0.181		0.208
L	0.5		1.27	0.019		0.050
M			0.68			0.026
S	8° (max.)					

Figure 18. Package dimensions

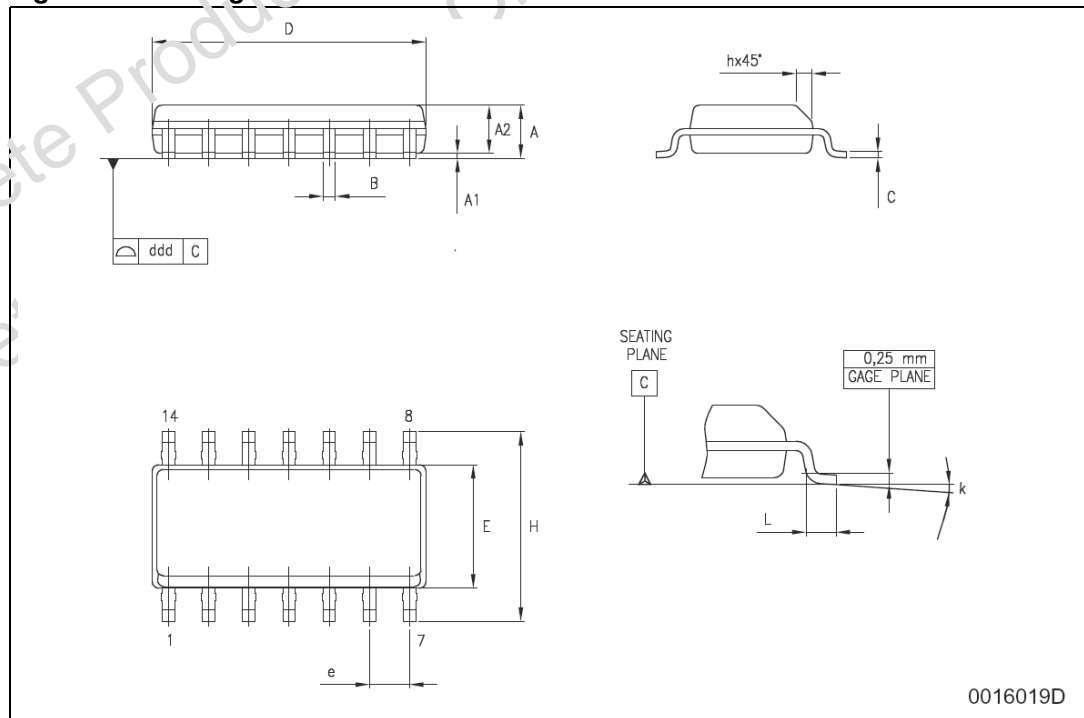

Table 11. TSSOP16 (Exposed pad) mechanical data

Dim.	mm.			inch		
	Min	Typ	Max	Min	Typ	Max
A1	0.05		0.15	0.002	0.004	0.006
A2	0.8	1	1.05	0.031	0.039	0.041
b	0.19		0.30	0.007		0.012
c	0.09		0.20	0.004		0.0079
D	4.9	5	5.1	0.193	0.197	0.201
E	6.2	6.4	6.6	0.244	0.252	0.260
E1	4.3	4.4	4.48	0.169	0.173	0.176
e		0.65 BSC			0.0256 BSC	
K	0°		8°	0°		8°
L	0.45	0.60	0.75	0.018	0.024	0.030

Figure 19. Package dimensions

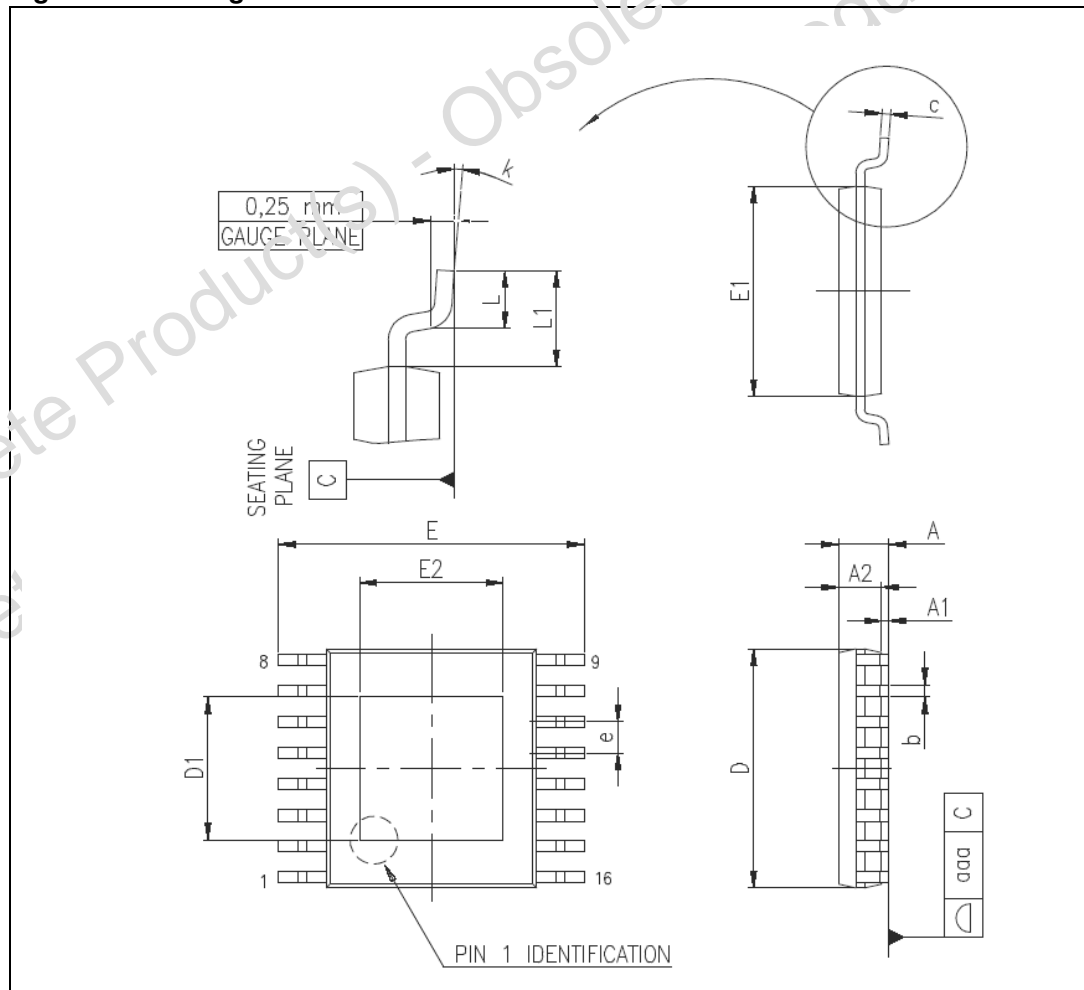

Table 12. Tape and reel SO-14

Dim.	mm.			inch		
	Min	Typ	Max	Min	Typ	Max
A			330			12.992
C	12.8		13.2	0.504		0.519
D	20.2			0.795		
N	60			2.362		
T			22.4			0.882
Ao	6.4		6.6	0.252		0.260
Bo	9		9.2	0.354		0.362
Ko	2.1		2.3	0.082		0.090
Po	3.9		4.1	0.153		0.161
P	7.9		8.1	0.311		0.319

Figure 20. Tape and reel dimensions

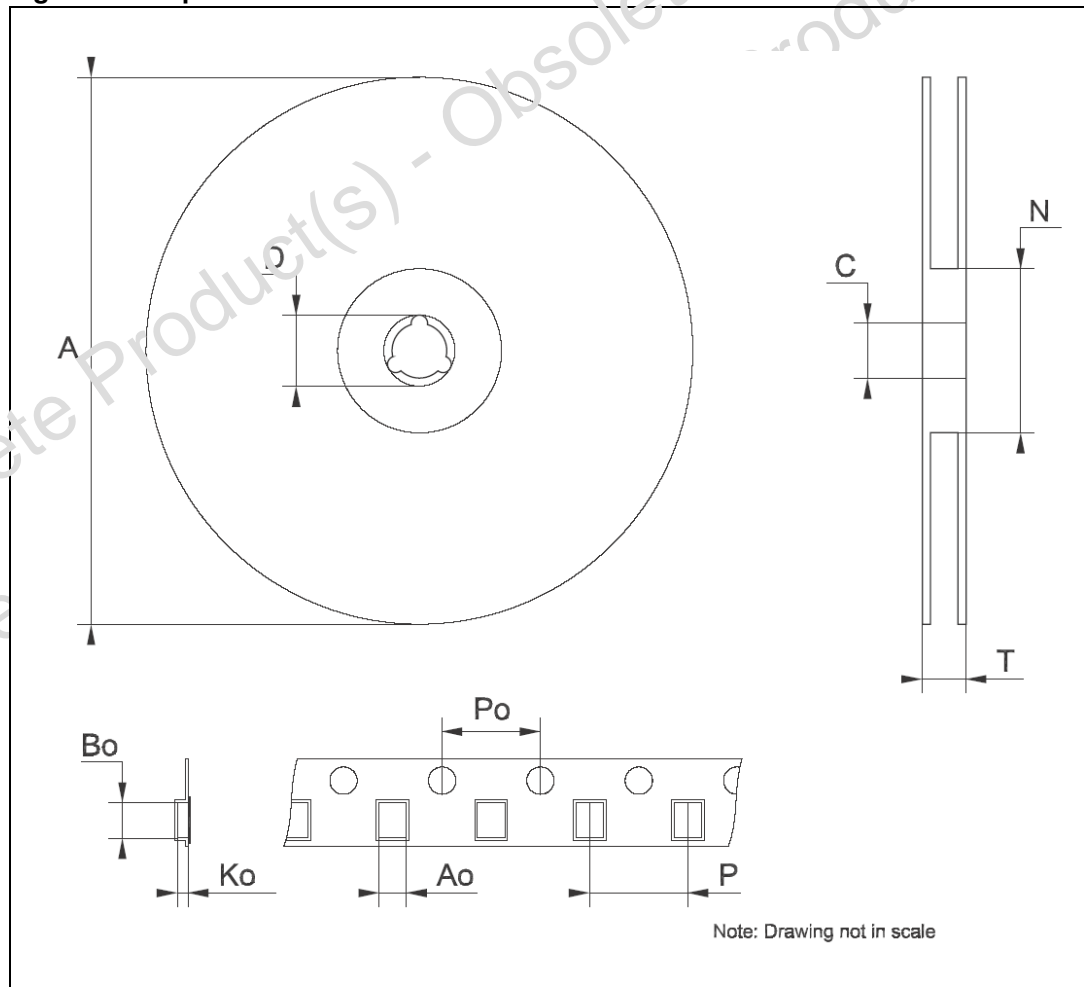
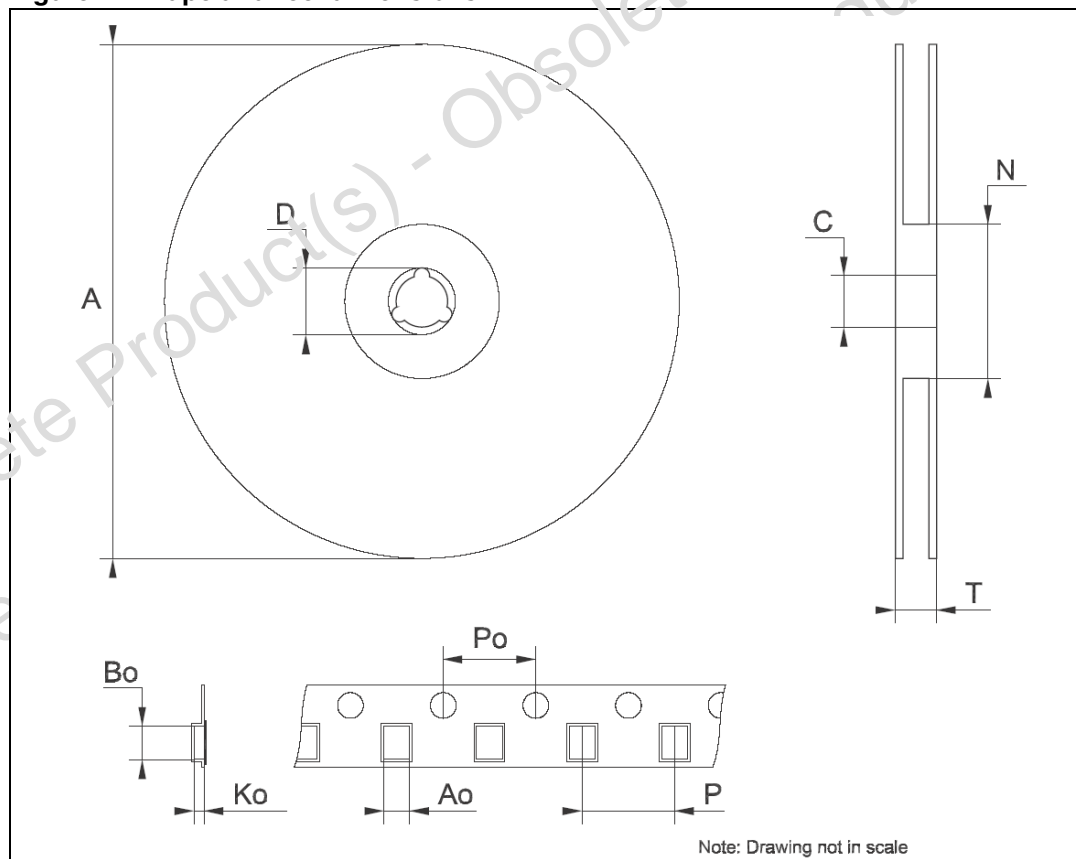

Table 13. TSSOP16 tape and reel

Dim.	mm.			inch		
	Min	Typ	Max	Min	Typ	Max
A			330			12.992
C	12.8		13.2	0.504		0.519
D	20.2			0.795		
N	60			2.362		
T			22.4			0.882
Ao	6.7		6.9	0.264		0.272
Bo	5.3		5.5	0.209		0.217
Ko	1.6		1.8	0.063		0.071
Po	3.9		4.1	0.153		0.161
P	7.9		8.1	0.311		0.319

Figure 21. Tape and reel dimensions



10 Revision history

Table 14. Revision history

Date	Revision	Changes
26-Oct-2006	1	Initial release
05-Apr-2006	2	New template
23-May-2006	3	Updated packaging information
08-Jun-2006	4	Typos in cover page
20-Jun-2006	5	Block diagram updated <i>Figure 1 on page 3</i> , equivalent circuits updated <i>Figure 3, 4, 5, 6, on page 9 and 10</i>

Please Read Carefully:

Information in this document is provided solely in connection with ST products. STMicroelectronics NV and its subsidiaries ("ST") reserve the right to make changes, corrections, modifications or improvements, to this document, and the products and services described herein at any time, without notice.

All ST products are sold pursuant to ST's terms and conditions of sale.

Purchasers are solely responsible for the choice, selection and use of the ST products and services described herein, and ST assumes no liability whatsoever relating to the choice, selection or use of the ST products and services described herein.

No license, express or implied, by estoppel or otherwise, to any intellectual property rights is granted under this document. If any part of this document refers to any third party products or services it shall not be deemed a license grant by ST for the use of such third party products or services, or any intellectual property contained therein or considered as a warranty covering the use in any manner whatsoever of such third party products or services or any intellectual property contained therein.

UNLESS OTHERWISE SET FORTH IN ST'S TERMS AND CONDITIONS OF SALE ST DISCLAIMS ANY EXPRESS OR IMPLIED WARRANTY WITH RESPECT TO THE USE AND/OR SALE OF ST PRODUCTS INCLUDING WITHOUT LIMITATION IMPLIED WARRANTIES OF MERCHANTABILITY, FITNESS FOR A PARTICULAR PURPOSE (AND THEIR EQUIVALENTS UNDER THE LAWS OF ANY JURISDICTION), OR INFRINGEMENT OF ANY PATENT, COPYRIGHT OR OTHER INTELLECTUAL PROPERTY RIGHT.

UNLESS EXPRESSLY APPROVED IN WRITING BY AN AUTHORIZED ST REPRESENTATIVE, ST PRODUCTS ARE NOT RECOMMENDED, AUTHORIZED OR WARRANTED FOR USE IN MILITARY, AIR CRAFT, SPACE, LIFE SAVING, OR LIFE SUSTAINING APPLICATIONS, NOR IN PRODUCTS OR SYSTEMS WHERE FAILURE OR MALFUNCTION MAY RESULT IN PERSONAL INJURY, DEATH, OR SEVERE PROPERTY OR ENVIRONMENTAL DAMAGE. ST PRODUCTS WHICH ARE NOT SPECIFIED AS "AUTOMOTIVE GRADE" MAY ONLY BE USED IN AUTOMOTIVE APPLICATIONS AT USER'S OWN RISK.

Resale of ST products with provisions different from the statements and/or technical features set forth in this document shall immediately void any warranty granted by ST for the ST product or service described herein and shall not create or extend in any manner whatsoever, any liability of ST.

ST and the ST logo are trademarks or registered trademarks of ST in various countries.

Information in this document supersedes and replaces all information previously supplied.

The ST logo is a registered trademark of STMicroelectronics. All other names are the property of their respective owners.

© 2006 STMicroelectronics - All rights reserved

STMicroelectronics group of companies

Australia - Belgium - Brazil - Canada - China - Czech Republic - Finland - France - Germany - Hong Kong - India - Israel - Italy - Japan - Malaysia - Malta - Morocco - Singapore - Spain - Sweden - Switzerland - United Kingdom - United States of America

www.st.com