



Chipsmall Limited consists of a professional team with an average of over 10 year of expertise in the distribution of electronic components. Based in Hongkong, we have already established firm and mutual-benefit business relationships with customers from,Europe,America and south Asia,supplying obsolete and hard-to-find components to meet their specific needs.

With the principle of "Quality Parts,Customers Priority,Honest Operation,and Considerate Service",our business mainly focus on the distribution of electronic components. Line cards we deal with include Microchip,ALPS,ROHM,Xilinx,Pulse,ON,Everlight and Freescale. Main products comprise IC,Modules,Potentiometer,IC Socket,Relay,Connector.Our parts cover such applications as commercial,industrial, and automotives areas.

We are looking forward to setting up business relationship with you and hope to provide you with the best service and solution. Let us make a better world for our industry!



Contact us

Tel: +86-755-8981 8866 Fax: +86-755-8427 6832

Email & Skype: info@chipsmall.com Web: www.chipsmall.com

Address: A1208, Overseas Decoration Building, #122 Zhenhua RD., Futian, Shenzhen, China



24-bit constant current LED sink driver with output error detection

Features

- Low-voltage power supply down to 3 V
- 8 x 3 constant current output channels
- Adjustable output current through external resistors
- Short and open output error detection
- Serial data IN/parallel data OUT
- Shift register data flow register control
- Accepts 3.3 V and 5 V micro driver
- Output current: 5-80 mA
- 25 MHz clock frequency
- High thermal efficiency package

Description

The STP24DP05 is a monolithic, low-voltage, low current power 24-bit shift register designed for LED panel displays. The device contains an 8 x 3-bit serial-IN, parallel-OUT shift register that feeds a 8 x 3-bit D-type storage register. In the output stage, twenty four regulated current sources were designed to provide 5-80 mA constant current to drive the LEDs.

The 8 x 3 shift register data flow sequence order can be managed through two dedicated pins.

The STP24DP05 has a dedicated pin to activate the outputs with a sequential delay, that prevents inrush current during output turn-ON.

The device detection circuit checks 3 different conditions that can occur on the output line: short to GND, short to V_O , or open line.

The data detection results are loaded in the shift registers and shifted out via the serial line output.

Table 1. Device summary

Order code	Package	Packaging
STP24DP05BTR	TQFP48-EP ⁽¹⁾	Tape and reel

1. Thermal pad size: 3.5 mm x 3.5 mm.

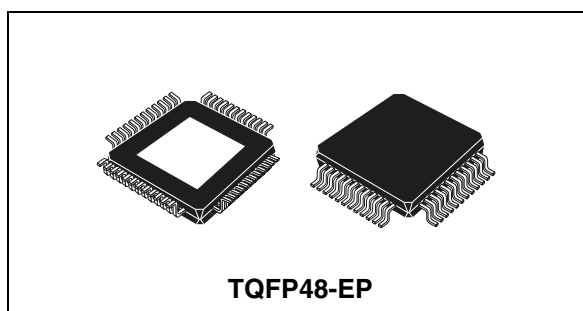

The detection functionality is activated with a dedicated pin or alternatively, through a logic sequence that allows the user to enter or exit detection mode.

Through three external resistors, the user can adjust the output current for each 8-channel group, therefore controlling the light intensity of LEDs.

The STP24DP05 guarantees a 20 V output driving capability, allowing the user to connect more LEDs in series.

The high clock frequency, 25 MHz, makes the device suitable for high data rate transmission.

The 3.3 V of voltage supply is useful for applications that interface any microcontroller from 3.3 V.

Contents

- 1 Summary description 3**
 - 1.1 Pin connection and description 3
- 2 Electrical ratings 5**
 - 2.1 Absolute maximum ratings 5
 - 2.2 Thermal data 5
 - 2.3 Recommended operating conditions 6
- 3 Electrical characteristics 7**
- 4 Block diagram 9**
- 5 Equivalent circuit and outputs 10**
- 6 Timing diagrams 12**
- 7 Features description 15**
 - 7.1 DG: gradual output delay 15
 - 7.2 Error detection condition 15
 - 7.3 Phase one: “entering detection mode” 16
 - 7.4 Phase two: “error detection” 17
 - 7.5 Phase three: “resuming normal mode” 18
 - 7.6 Shift register data flow control 18
 - 7.7 EFLAG/TFLAG - output detection and overtemperature monitoring 19
- 8 Typical application schematic 20**
- 9 Typical characteristics 21**
- 10 Package mechanical data 22**
- 11 Revision history 26**

1 Summary description

Table 2. Current accuracy

Output voltage	Typical current accuracy		Output current	V _{DD}	Temperature
	Between bits	Between ICs			
≥ 1.0 V	± 3%	± 6%	≥ 15 to 80 mA	3.3 V to 5 V	25 °C
≥ 0.2 V	± 6%	± 6%	5 to 15 mA		

1.1 Pin connection and description

Figure 1. Pin connection

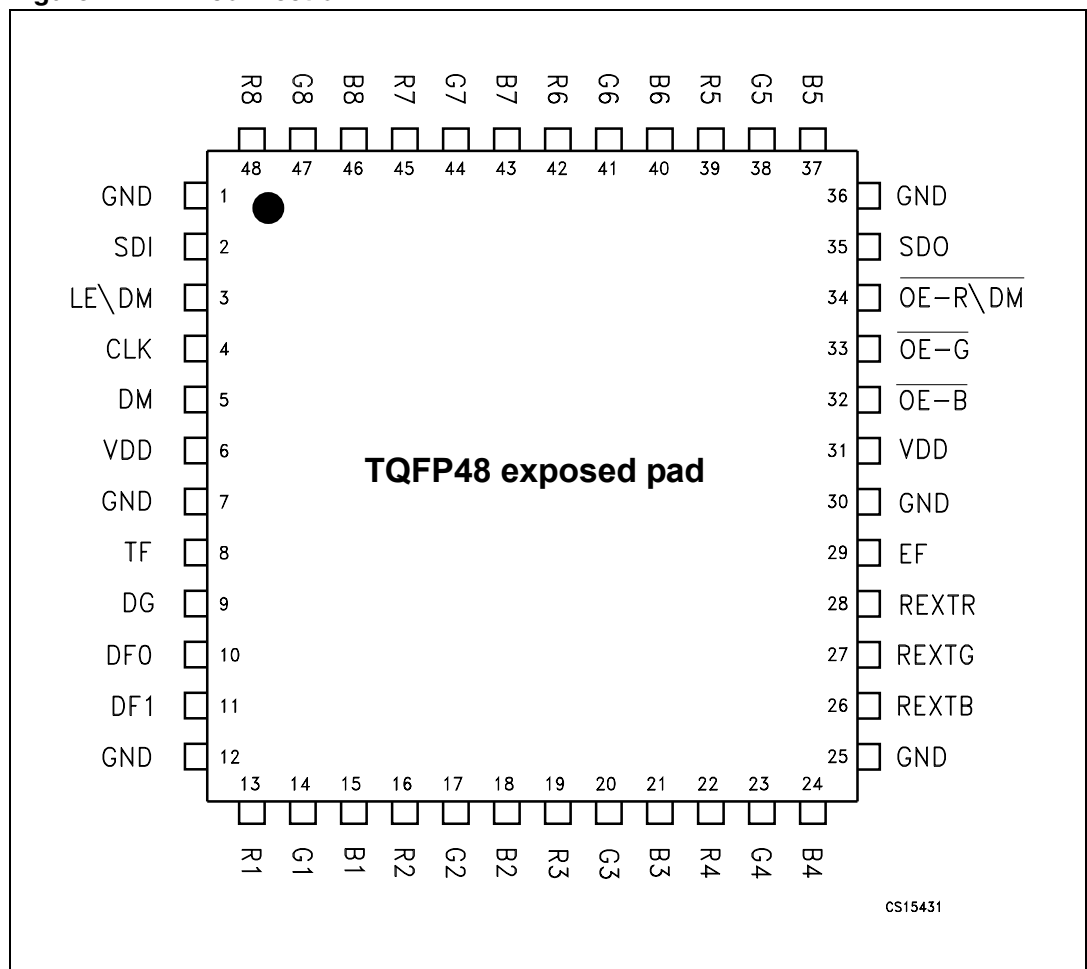

Note: *The exposed pad should be electrically connected to a PCB metal dissipation area electrically isolated or connected to ground.*

Table 3. Pin description

Pin N°	Symbol	Name and function
1, 7, 12, 25, 30, 36	GND	Ground terminal
2	SDI	Serial data input
35	SDO	Serial data output
4	CLK	Clock for serial data
3	LE\DM	Data latch in both SH registers
5	DM	Detection mode pin
13, 16, 19, 22, 39, 42, 45, 48	R1 - 8	8-channel LED driver outputs
8	TF	Thermal flag (open drain)
29	EF	Error detection flag (open drain)
9	DG	Gradual delay
15, 18, 21, 24 37, 40, 43, 46	B1 - 8	8-channel LED driver outputs
32	$\overline{OE-B}$	Output enable for B1 - 8
33	$\overline{OE-G}$	Output enable for G1 - 8
34	$\overline{OE-R\backslash DM}$	Output enable for R1 - 8
28	REXTR	Control outputs R1 - 8
27	REXTG	Control outputs G1 - 8
26	REXTB	Control outputs B1 - 8
14, 17, 20, 23 38, 41, 44, 48	G1 - 8	8-channel LED driver outputs
10	DF0	Data banks flow bit 0
11	DF1	Data banks flow bit 1
31	VDD	Supply voltage terminal

2 Electrical ratings

2.1 Absolute maximum ratings

Stressing the device above the ratings listed in [Table 4](#) may cause permanent damage to the device. These are stress ratings only and operation of the device at these or any other conditions above those indicated in the operating sections of this specification is not implied. Exposure to absolute maximum rating conditions for extended periods may affect device reliability.

Table 4. Absolute maximum ratings

Symbol	Parameter	Value	Unit
V_{DD}	Supply voltage - digital	0 to 7	V
V_O	Output voltage - LED driver	-0.5 to 20	V
V_{TF} and V_{ER}	Open drain absolute voltage	0 to 7	V
I_O	Output current - LED driver	80	mA
V_I	Input voltage - digital	-0.4 to $V_{DD}+0.4$	V
I_{GND}	GND terminal current	2000	mA
f_{CLK}	Clock frequency	30	MHz

2.2 Thermal data

Table 5. Thermal data

Symbol	Parameter	Value	Unit
T_{OPR}	Operating temperature range	-40 to 125	°C
T_{STG}	Storage temperature range	-40 to 150	°C
R_{thJA}	Thermal resistance junction-ambient ⁽¹⁾ ⁽²⁾	33	°C/W

1. The exposed pad should be soldered directly to the PCB to realize the thermal benefits.
2. Packages tested on multi-layer (1S2P) JEDEC compliant test boards.

2.3 Recommended operating conditions

Table 6. Recommended operating conditions

Symbol	Parameter	Test conditions	Min.	Typ.	Max.	Unit
V_{DD}	Supply voltage		3.0		5.5	V
V_O	Output voltage				20	V
I_O	Output current	OUTn	5		80	mA
I_{OH}	Output current	Serial-OUT		+10		mA
I_{OL}	Output current	Serial-OUT		-10		mA
V_{IH}	Input voltage		$0.7 V_{DD}$		$V_{DD}+0.3$	V
V_{IL}	Input voltage		-0.3		$0.3 V_{DD}$	V
t_{wLAT}	LE pulse width	$V_{DD} = 3.0\text{ V to }5.0\text{ V}$	15			ns
t_{wCLK}	CLK pulse width		15			ns
t_{wEN}	\overline{OE} pulse width		150			ns
$t_{SETUP(D)}$	Setup time for DATA		15			ns
$t_{HOLD(D)}$	Hold time for DATA		5			ns
$t_{SETUP(L)}$	Setup time for LATCH		10			ns
f_{CLK}	Clock frequency		Cascade operation ⁽¹⁾			25

1. If the device is connected in cascade, it may not be possible to achieve the maximum data transfer. Please consider the timings carefully.

3 Electrical characteristics

T = 25 °C, unless otherwise specified.

Table 7. Electrical characteristics (V_{DD} = 3.3 V to 5 V)

Symbol	Parameter	Test conditions	Min.	Typ.	Max.	Unit
V _{IH}	Input voltage high level		0.7 V _{DD}		V _{DD}	V
V _{IL}	Input voltage low level		GND		0.3 V _{DD}	V
I _{OH}	Output leakage current	V _{OH} = 20 V			10	μA
V _{OL}	Output voltage (Serial-OUT)	I _{OL} = 1 mA			0.4	V
V _{OH}	Output voltage (Serial-OUT)	I _{OH} = -1 mA	V _{DD} -0.4 V			V
I _{OL1}	Output current	V _O = 0.3 V, R _{EXT} = 2 kΩ, I _O = 10 mA		10		mA
I _{OL2}		V _O = 0.3 V, R _{EXT} = 1 kΩ, I _O = 20 mA		20		mA
I _{OL3}		V _O = 0.3 V, R _{EXT} = 250 Ω, I _O = 80 mA		80		mA
ΔI _{OL1}	Output current error among the channels (All outputs ON)	V _O = 0.3 V, R _{EXT} = 2 kΩ, I _O = 10 mA		± 2	± 3	%
ΔI _{OL2}		V _O = 0.3 V, R _{EXT} = 1 kΩ, I _O = 20 mA		± 2	± 3	%
ΔI _{OL3}		V _O = 0.3 V, R _{EXT} = 250 Ω, I _O = 80 mA		± 2	± 3	%
R _{SIN(up)}	Pull-up resistor		300	600	800	kΩ
R _{SIN(down)}	Pull-down resistor		300	400	500	kΩ
LE _(up) DG _(up) OE-R\ DM (up) OE-G (up) OE-B (up) DF0 DF1	Pull-up resistor		300	400	500	kΩ
I _{DD(OFF1)}	Supply current (OFF)	R _{EXT} = 1 kΩ OUT 0 to 15 = OFF		9	12	mA
I _{DD(OFF2)}		R _{EXT} = 250 Ω OUT 0 to 15 = OFF		32	40	
I _{DD(ON1)}	Supply current (ON)	R _{EXT} = 1 kΩ OUT 0 to 15 = ON		13	18	
I _{DD(ON2)}		R _{EXT} = 250 Ω OUT 0 to 15 = ON		35	40	

Table 7. Electrical characteristics (V_{DD} = 3.3 V to 5 V) (continued)

Symbol	Parameter	Test conditions	Min.	Typ.	Max.	Unit
Thermal	Thermal protection			170		°C
V _{TF}	Output voltage				5	V
I _{TF}	Output current	V _{TF} @ 1 V	20			mA
V _{EF}	Output voltage				5	V
I _{EF}	Output current	V _{EF} @ 1 V	20			mA

Table 8. Switching characteristics (V_{DD} = 3.3 V, 5 V)

Symbol	Parameter	Test conditions	Min.	Typ.	Max.	Unit	
t _{PLH1}	Propagation delay time, CLK-OUTn, LE = H, OE = L	V _{IH} = V _{DD} V _{IL} = GND I _O = 20 mA R _{EXT} = 1 kΩ C _L = 10 pF V _L = 3.0 V R _L = 60 Ω	V _{DD} = 3.3 V		62	100	ns
			V _{DD} = 5 V		38	60	
t _{PLH2}	Propagation delay time, LE-OUTn, OE = L		V _{DD} = 3.3 V		67	107	ns
			V _{DD} = 5 V		44	60	
t _{PLH3}	Propagation delay time, OE-OUTn, LE = H		V _{DD} = 3.3 V		65	83	ns
			V _{DD} = 5 V		38	45	
t _{PLH}	Propagation delay time, CLK-SDO		V _{DD} = 3.3 V	14	22	36	ns
			V _{DD} = 5 V	9	14	23	
t _{PHL1}	Propagation delay time, CLK-OUTn, LE = H, OE = L		V _{DD} = 3.3 V		46	70	ns
			V _{DD} = 5 V		39	50	
t _{PHL2}	Propagation delay time, LE-OUTn, OE = L		V _{DD} = 3.3 V		51	76	ns
			V _{DD} = 5 V		46	55	
t _{PHL3}	Propagation delay time, OE-OUTn, LE = H		V _{DD} = 3.3 V		41	45	ns
			V _{DD} = 5 V		33	39	
t _{PHL}	Propagation delay time, CLK-SDO	V _{DD} = 3.3 V	15	24	38	ns	
		V _{DD} = 5 V	9	15	24		
t _{ON}	Output rise time 10~90% of voltage waveform	V _{DD} = 3.3 V		33	57	ns	
		V _{DD} = 5 V		17	27		
t _{OFF}	Output fall time 90~10% of voltage waveform	V _{DD} = 3.3 V		24	34	ns	
		V _{DD} = 5 V		25	37		
t _r	CLK rise time ⁽¹⁾				5000	ns	
t _f	CLK fall time ⁽¹⁾				5000	ns	

1. In order to achieve high cascade data transfer, please consider tr/tf timings carefully.

4 Block diagram

Figure 2. Block diagram

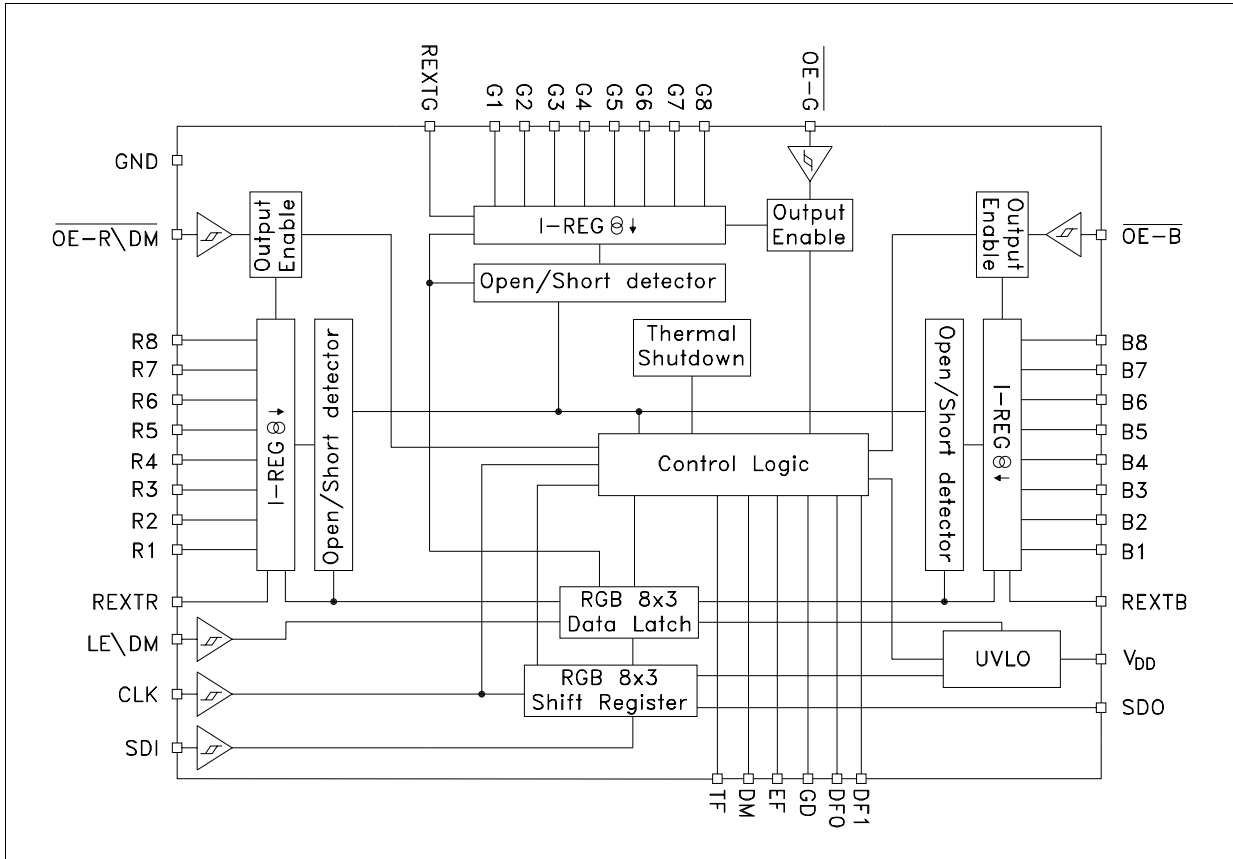

5 Equivalent circuit and outputs

Figure 3. $\overline{OE}xx$ terminal

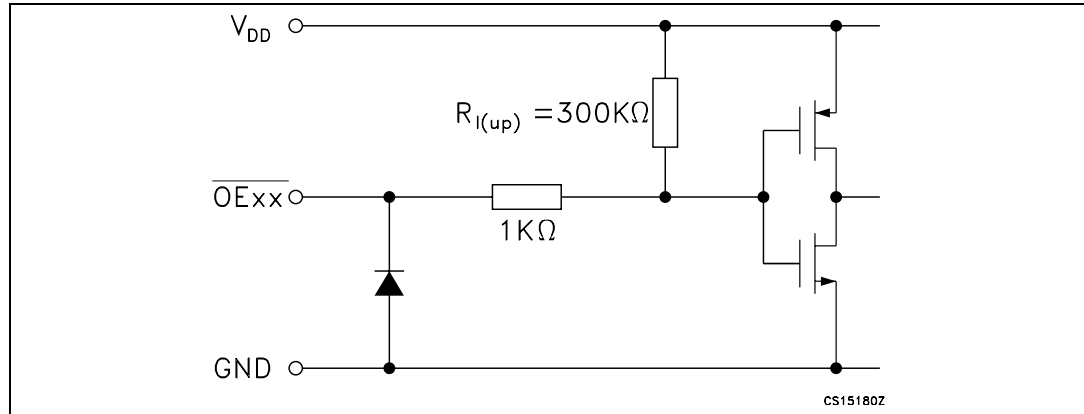

Figure 4. LE\DM terminal

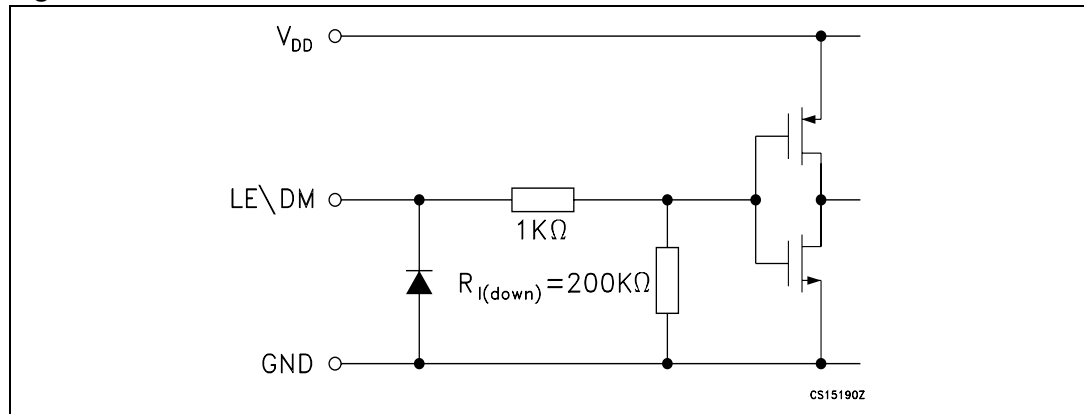

Figure 5. CLK, SDI terminal

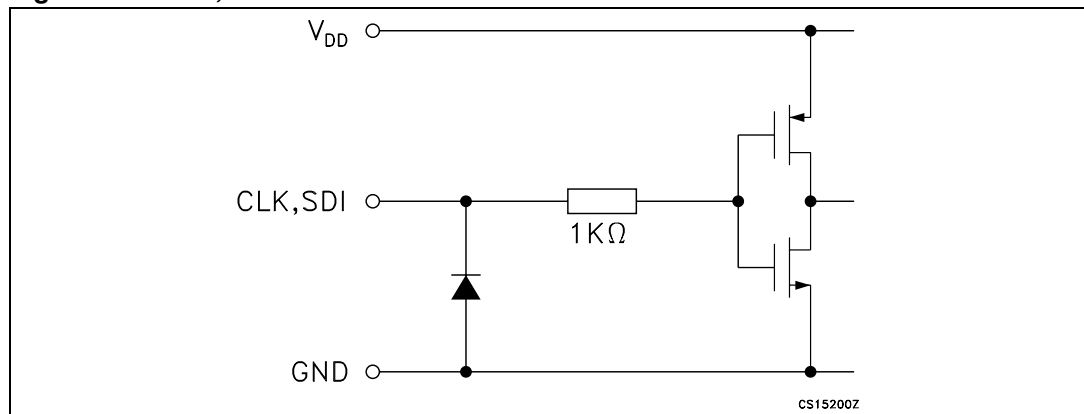

Figure 6. SDO terminal

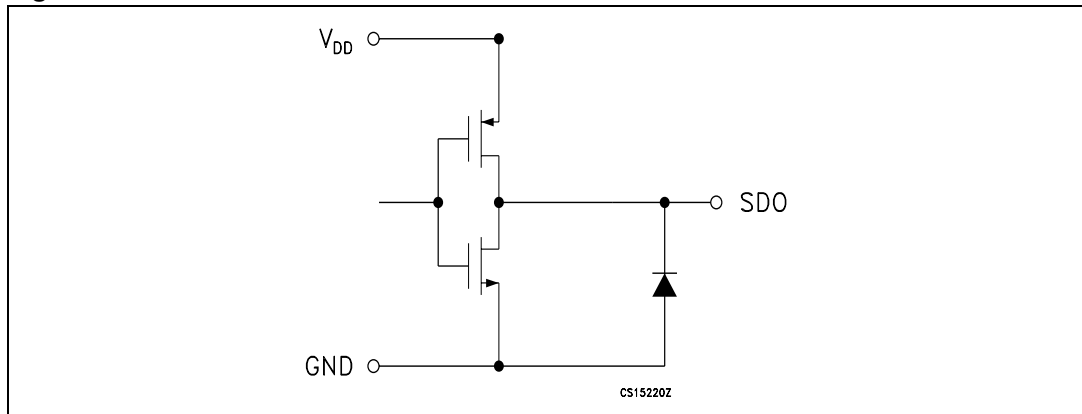
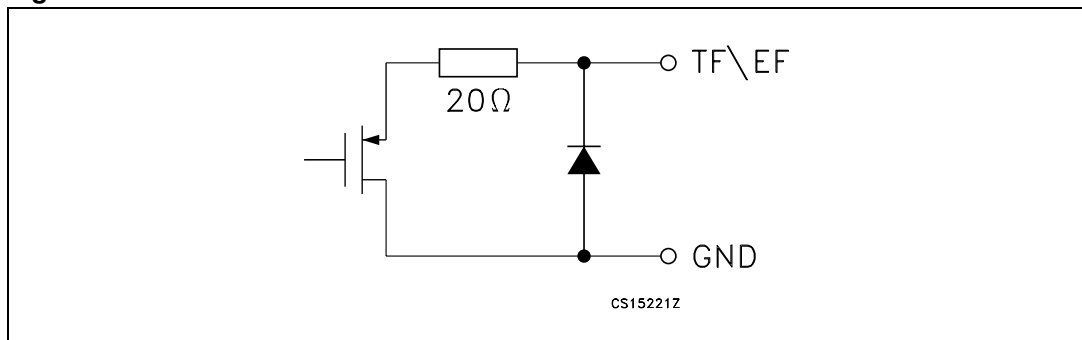
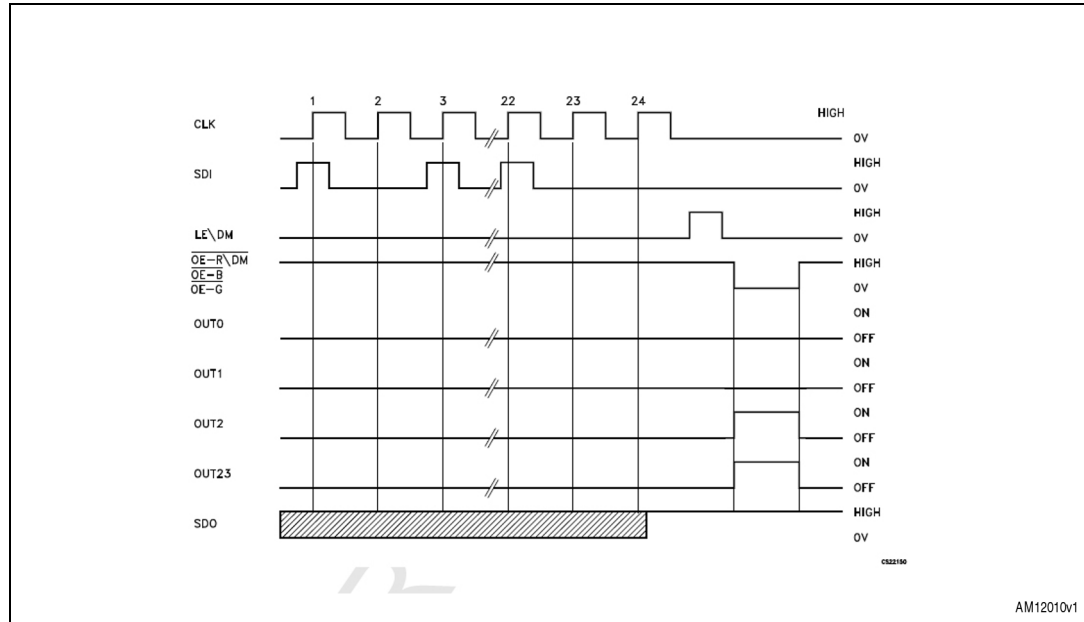

Figure 7. TF and EF



6 Timing diagrams

Figure 8. Timing diagram



- Note:
- 1 Latch and output enable are level sensitive and are not synchronized with rising-or-falling edge of CLK signal.
 - 2 When LE\DM terminal is low level, the latch circuit holds the previous set of data.
 - 3 When LE\DM terminal is high level, the latch circuit refreshes the new set of data from the SDI chain.
 - 4 When either $\overline{OE-R\DM}$, $\overline{OE-G}$, or $\overline{OE-B}$ terminals are at low level, output terminals R\G\B1 to R\G\B8 respond to the data, either ON or OFF.
 - 5 When either $\overline{OE-R\DM}$, $\overline{OE-G}$, or $\overline{OE-B}$ terminals are at high level, all the data on the output terminal R\G\B1 to R\G\B8 is switched off.
 - 6 This device can customize the RGB sequence serial data flow by means of setting DF0 and DF1 (refer to [Table 14](#)).

Figure 9. Clock, serial-IN, serial-OUT

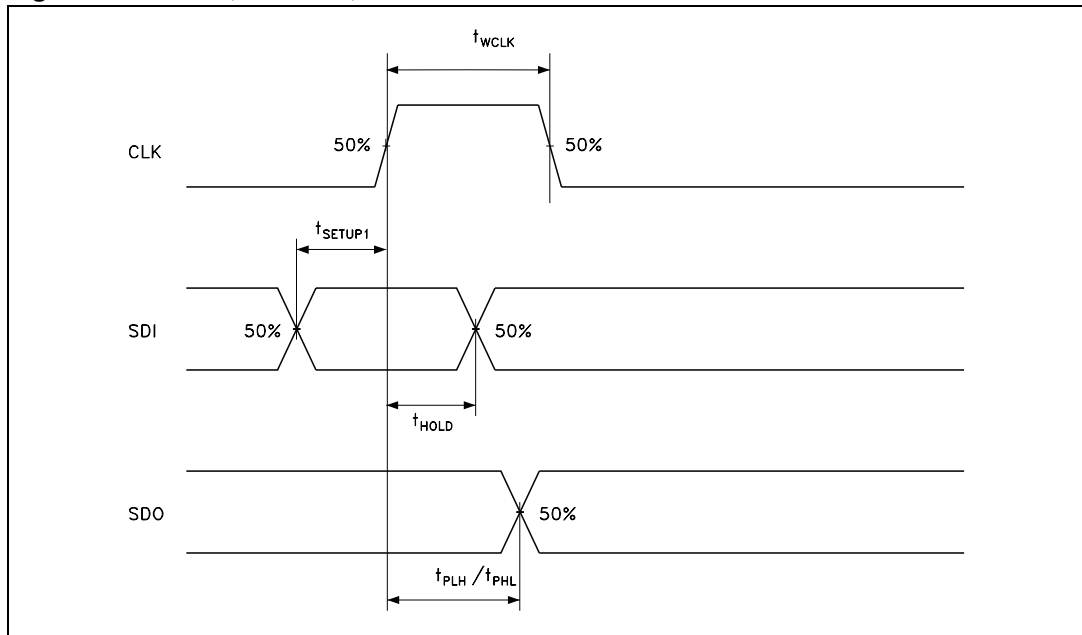

Figure 10. Clock, serial-IN, latch, enable, outputs

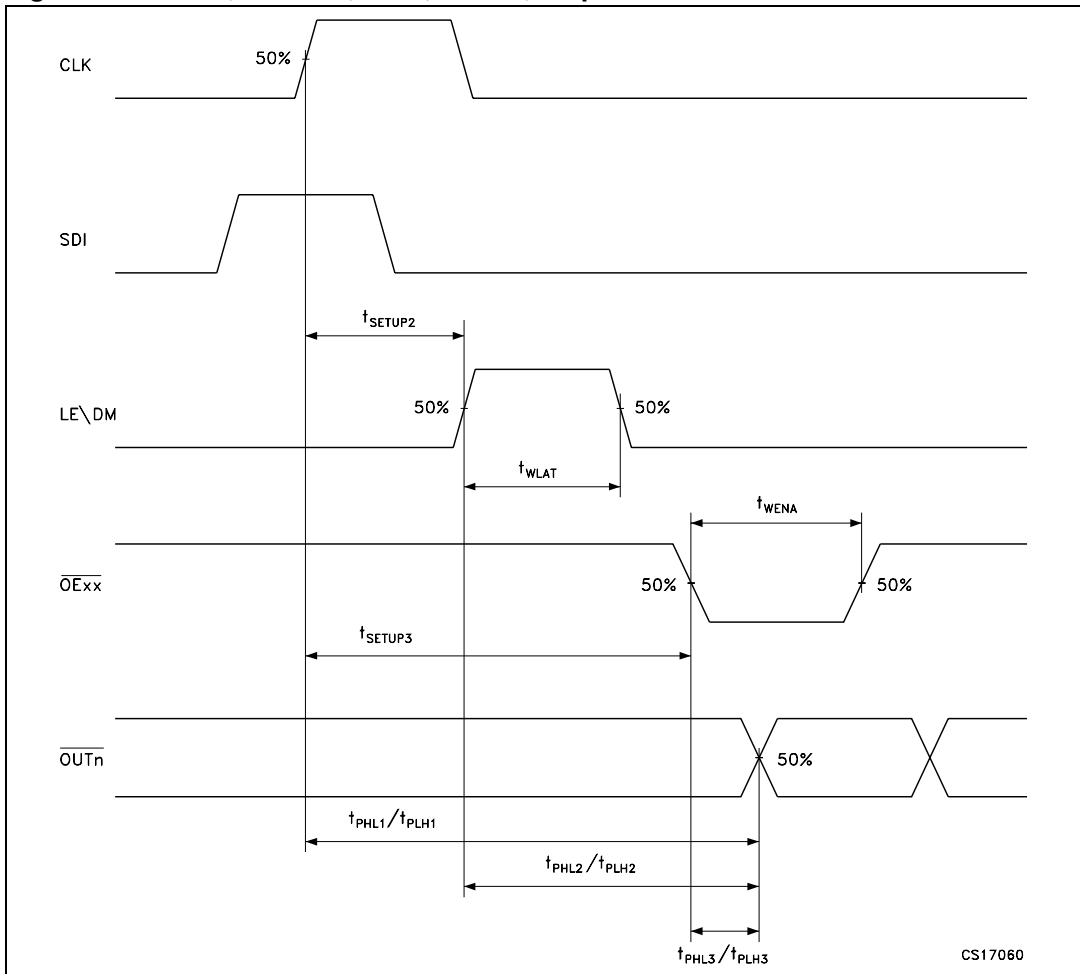
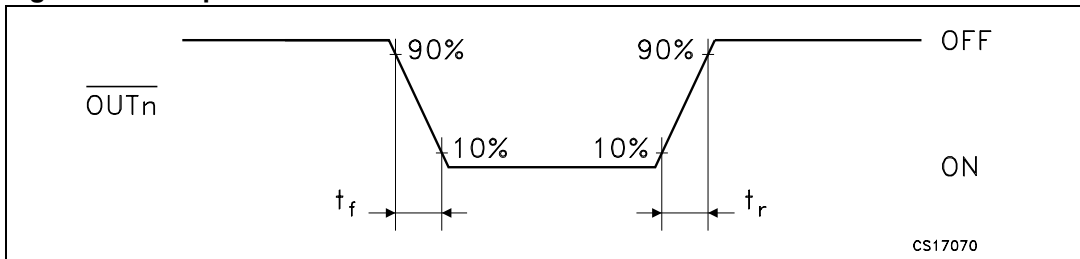

Figure 11. Outputs



7 Features description

7.1 DG: gradual output delay

This feature prevents large inrush current and reduces the bypass capacitors.

The fixed delay time can be activated with DG = LOW and the typical output delay is 30 ns for each group of 8 outputs, R, G, and B. E.g.: R1, G1, B1 has no delay, R2, G2, B2 has 30 ns delay and R3, G3, B3, has 60 ns delay, etc.

Table 9. Typical gradual delay time table

Delay time (ns) from $\overline{\text{OE}}_{\text{xx}}$	R1	R2	R3	R4	R5	R6	R7	R8
	G1 B1	G2 B2	G3 B3	G4 B4	G5 B5	G6 B6	G7 B7	G8 B8
DG = 0	0	30	60	90	120	150	180	210
DG = 1		0	0	0	0	0	0	0

7.2 Error detection condition

Table 10. Detection conditions ($V_{\text{DD}} = 3.3$ to 5 V, $I_{\text{O}} = 20$ mA, $t_{\text{A}} = 25$ °C)

SW-1 Open or SW-3b	Open line or output short to GND detected	$\Rightarrow I_{\text{ODEC}} \leq 0.4 \times I_{\text{O}}$	No error detected	$\Rightarrow I_{\text{ODEC}} \geq 0.35 \times I_{\text{O}}$
SW-2 Closed or SW-3a	Short on LED or short to V-LED detected	$\Rightarrow V_{\text{O}} \geq 2.6$ V	No error detected	$\Rightarrow V_{\text{O}} \leq 2.4$ V

Note: I_{O} = the output current programmed by the R_{EXT}
 I_{ODEC} = the detected output current in detection mode

Table 11. Typical current threshold values to detect LED open line

Iset (mA)	Rext (Ω)	Typ. out current detection (mA)
5	3920	1.28
10	1960	2.45
20	980	7.4
50	386	17
80	241	27

Figure 12. Detection circuit

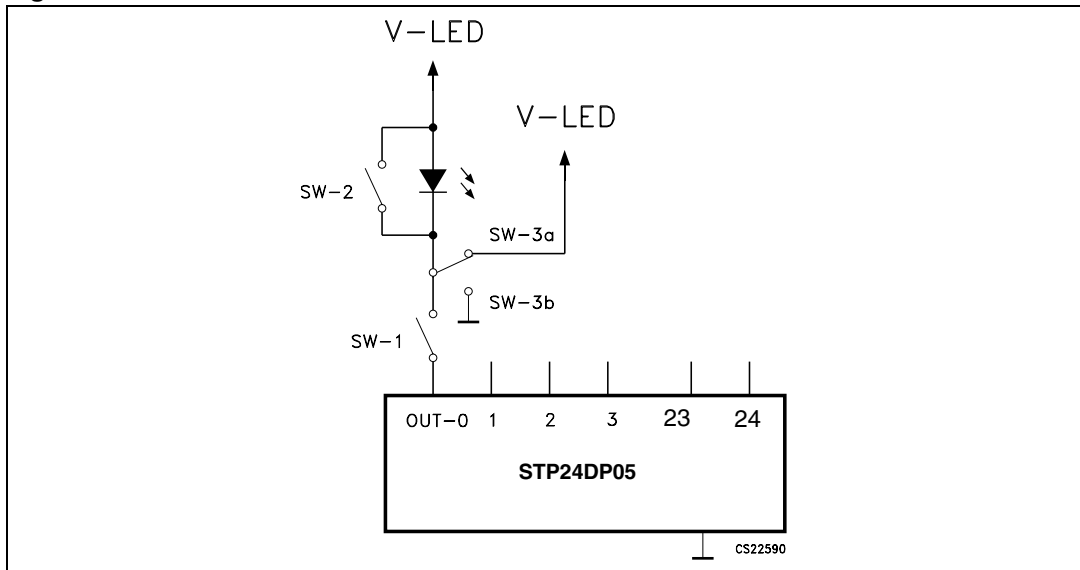

7.3 Phase one: “entering detection mode”

From the “normal mode” condition the device can switch to the “error detection mode” through a DM PIN set to LOW or a logic sequence on the $\overline{OE-R\backslash DM}$ and $LE\backslash DM$ pins as shown in [Figure 13](#), [14](#) and [Table 12](#):

Figure 13. EDM timing diagram using a DM pin

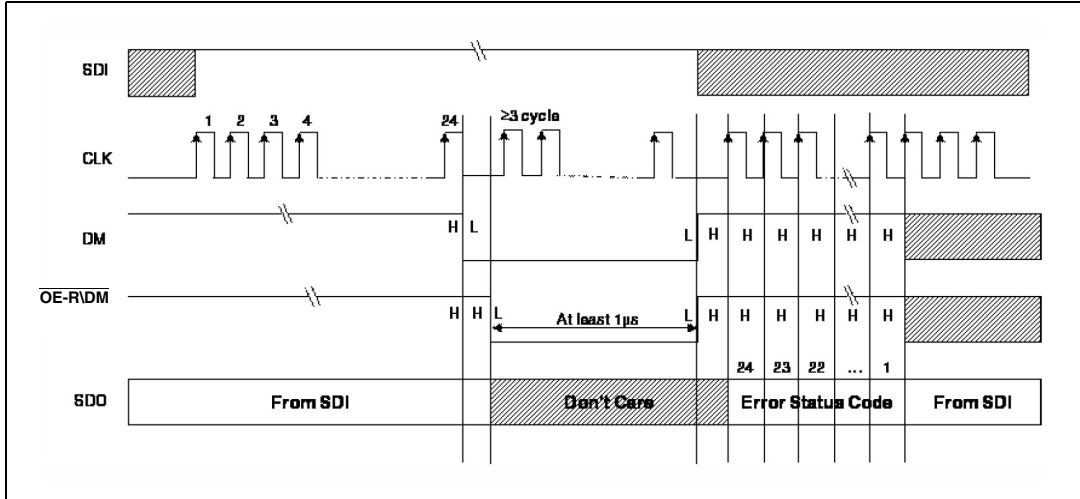
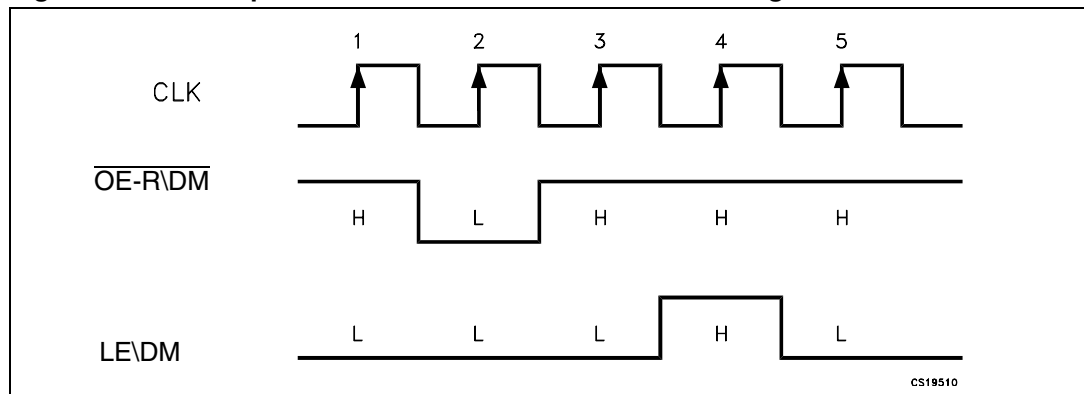

Table 12. SPI sequence to enter detection mode - truth table

CLK	1°	2°	3°	4°	5°
$\overline{OE-R\backslash DM}$	H	L	H	H	H
$LE\backslash DM$	L	L	L	H	L

Figure 14. SPI sequence to enter detection mode - time diagram



After these five CLK cycles the device goes into “error detection mode” and at the 6th rise front of CLK, the SDI data are ready for the sampling.

7.4 Phase two: “error detection”

The eight data bits must be set “1” in order to set all the outputs ON during detection. The data are latched by LE\DM and after that the outputs are ready for the detection process. When the microcontroller switches the OE-R\DM to LOW, the device drives the LEDs in order to analyze if an OPEN or SHORT condition has occurred.

Figure 15. Detection diagram

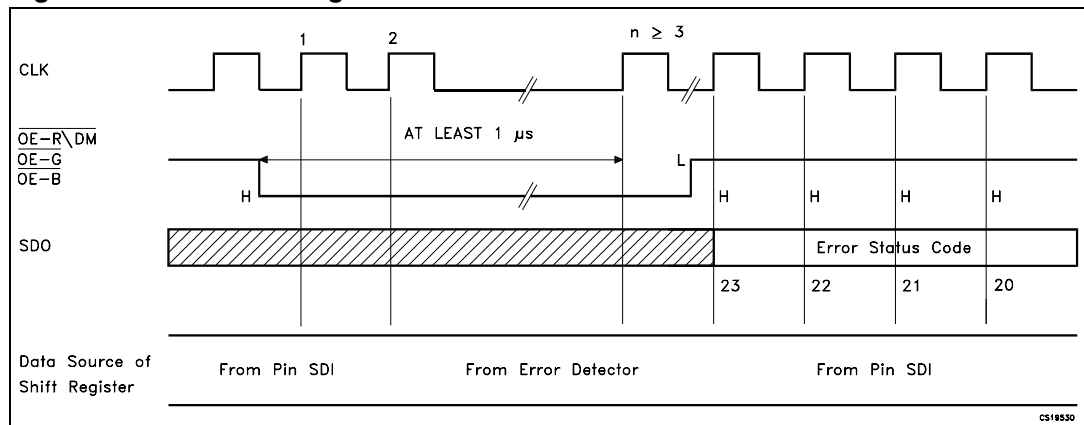

The LED status is detected after at least 1 microsecond and after this time the microcontroller sets OE-R\DM in HIGH state and the output data detection result goes to the microprocessor via the SDO pin.

Detection mode and normal mode both use the same format data. As soon as all the detection data bits are available on the serial line, the device may go back to normal operation mode. The result of the error detection is shifted out of the SDO pin providing 24 clock pulses. A faulty output is indicated as “0”, whereas a good output is indicated as “1”.

The result is shifted out according to the selected data flow (DF0 and DF1 status, see [Section 7.6](#)).

7.5 Phase three: “resuming normal mode”

In order to re-enter normal mode, either the LE\DM pin or the sequence shown in the following table can be used:

Table 13. SPI sequence to resume in normal mode - truth table

CLK	1°	2°	3°	4°	5°
$\overline{\text{OE-R}}\text{DM}$	H	L	H	H	H
LE\DM	L	L	L	L	L

Note: For proper device operation the “entering detection” sequence must be followed by a “resume mode” sequence, it is not possible to insert a consecutive equal sequence.

7.6 Shift register data flow control

The 8x3 shift registers have a default RGB sequence serial data flow as show in the block diagram of [Figure 2](#).

The data can be redirected by the DF0 and DF1 pins, these pins change the order of the data flow according to the following table:

Table 14. Shifter register data flow control

Sequence	DF0	DF1
BGR	1	1
BRG	0	1
RGB	1	0
GRB	0	0

The status of pins DF0 and DF1 also influences the sequence of the error detection result shifted out of the SDO pin.

Note: If the DF0 and DF1 pins are left floating, they are pulled-up to Vdd by internal pull-up resistors. In such conditions, the shift register sequence is set to BGR.

7.7 EFLAG/TFLAG - output detection and overtemperature monitoring

The open drain output EFLAG and TFLAG are used to report the STP24DP05 status flags. During normal operating conditions, the EFLAG/TFLAG pins should be pulled up through an external resistor. The EFLAG is turned on (shorted to GND) while the error detection is running. The TFLAG is turned on (shorted to GND) when the silicon temperature exceeds 180 °C.

Figure 16. TF and EF test circuit

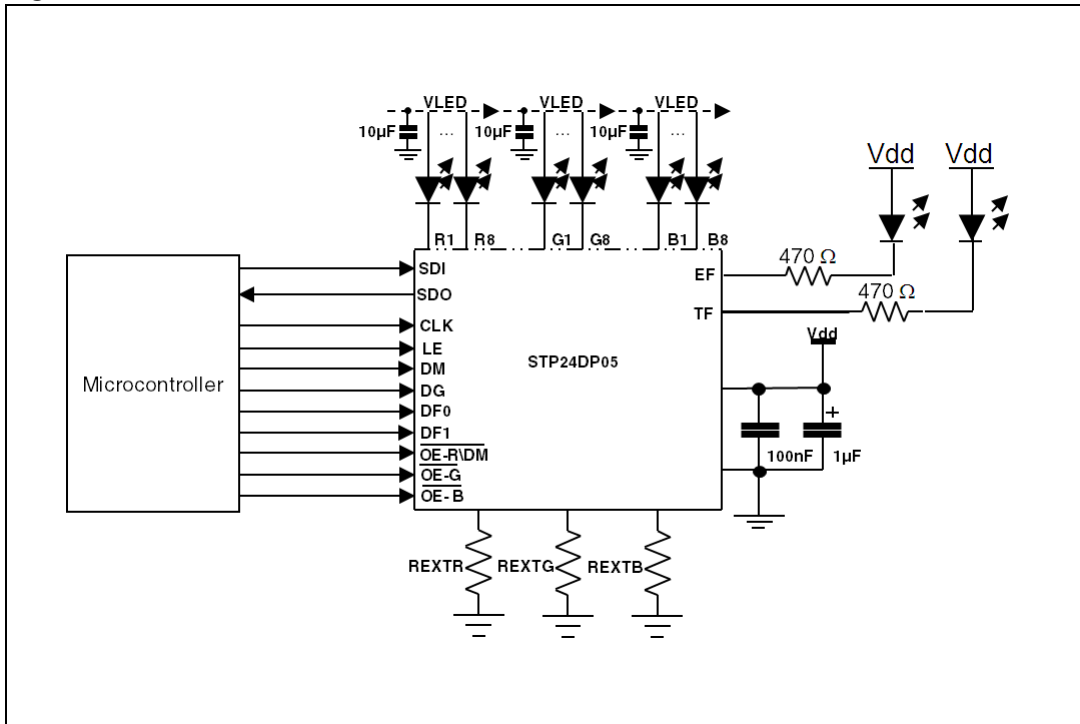

8 Typical application schematic

Figure 17. Typical application schematic

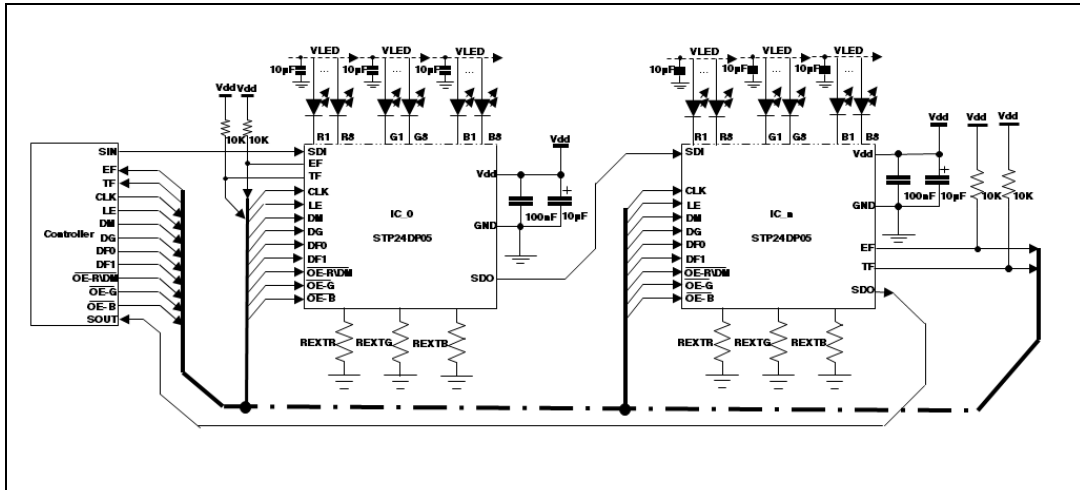

9 Typical characteristics

Figure 18. Typical external resistor values vs. output current capabilities

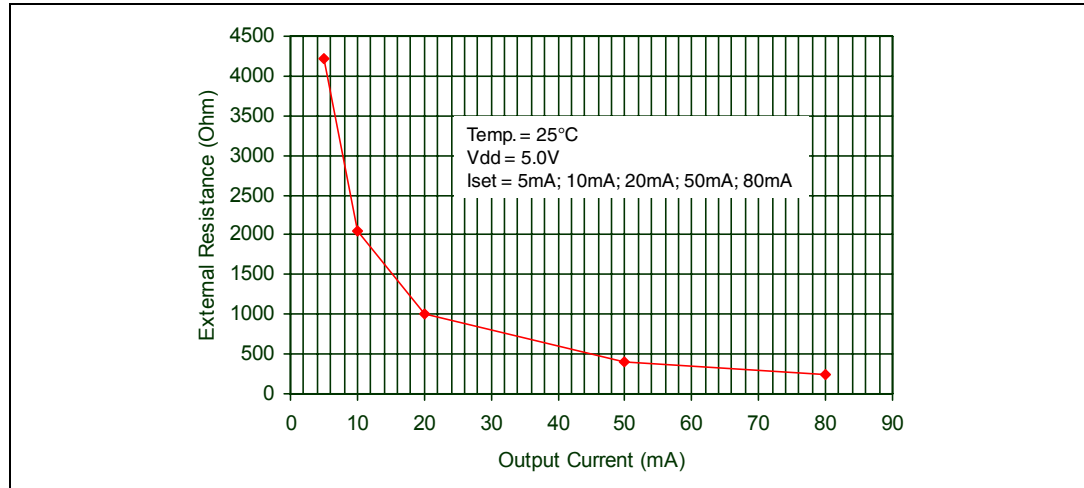

Table 15. Typical external resistor values vs. output current capabilities

Iset	5 mA	10 mA	20 mA	50 mA	80 mA
Rext (Ω)	4210	2050	1000	400	249

Figure 19. Typical dropout voltage vs. output current

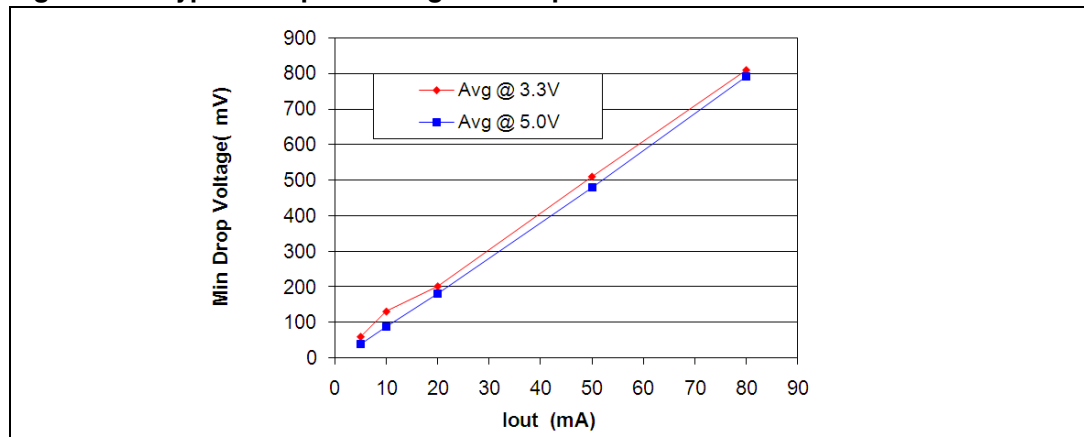

Table 16. Typical dropout voltage vs. output current

Iset	Rext (Ω)	Avg (mV) @ 3.3 V	Avg (mV) @ 5.0 V
5	4210	59	41
10	2050	130	90
20	1000	201	180
50	400	500	480
80	249	810	790

10 Package mechanical data

In order to meet environmental requirements, ST offers these devices in different grades of ECOPACK® packages, depending on their level of environmental compliance. ECOPACK specifications, grade definitions and product status are available at: www.st.com. ECOPACK is an ST trademark.

Table 17. TQFP48-EP mechanical data

Dim.	Min.	Typ.	Max
A			1.20
A1	0.05		0.15
A2	0.95	1.00	1.05
b	0.17	0.22	0.27
c	0.09		0.20
D	8.80	9.00	9.20
D1	6.80	7.00	7.20
D2		3.50	
D3		5.50	
E	8.80	9.00	9.20
E1	6.80	7.00	7.20
E2		3.50	
E3		5.50	
e		0.50	
L	0.45	0.60	0.75
L1		1.00	
k	0	3.5	7
ccc			0.08

Figure 20. TQFP48-EP mechanical data

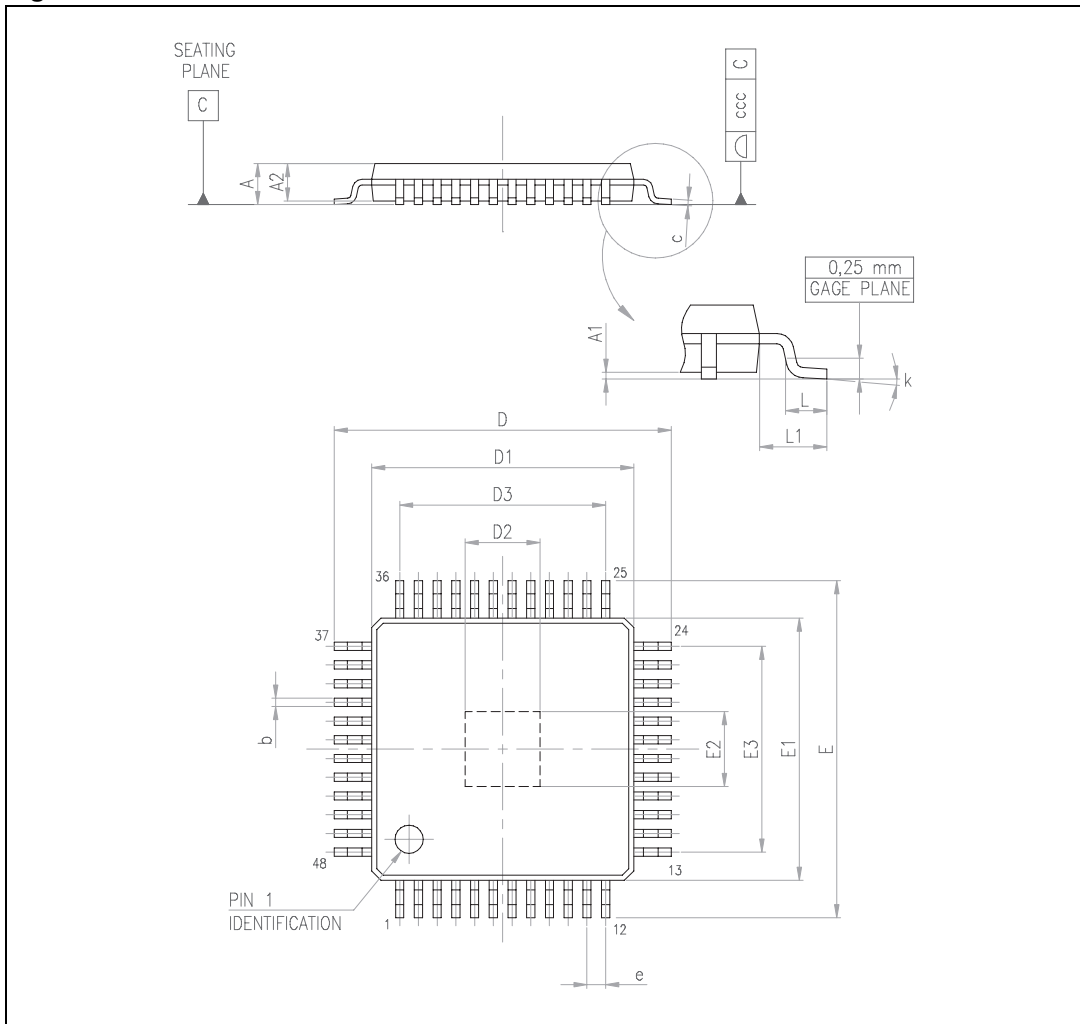

Figure 21. Tape and reel TQFP48-EP

