



Chipsmall Limited consists of a professional team with an average of over 10 year of expertise in the distribution of electronic components. Based in Hongkong, we have already established firm and mutual-benefit business relationships with customers from,Europe,America and south Asia,supplying obsolete and hard-to-find components to meet their specific needs.

With the principle of “Quality Parts,Customers Priority,Honest Operation,and Considerate Service”,our business mainly focus on the distribution of electronic components. Line cards we deal with include Microchip,ALPS,ROHM,Xilinx,Pulse,ON,Everlight and Freescale. Main products comprise IC,Modules,Potentiometer,IC Socket,Relay,Connector.Our parts cover such applications as commercial,industrial, and automotives areas.

We are looking forward to setting up business relationship with you and hope to provide you with the best service and solution. Let us make a better world for our industry!



Contact us

Tel: +86-755-8981 8866 Fax: +86-755-8427 6832

Email & Skype: info@chipsmall.com Web: www.chipsmall.com

Address: A1208, Overseas Decoration Building, #122 Zhenhua RD., Futian, Shenzhen, China



N-channel 80 V, 0.0017 Ω typ., 180 A, STripFET™ F7
Power MOSFETs in H²PAK-2, H²PAK-6 and TO-220 packages

Datasheet – production data

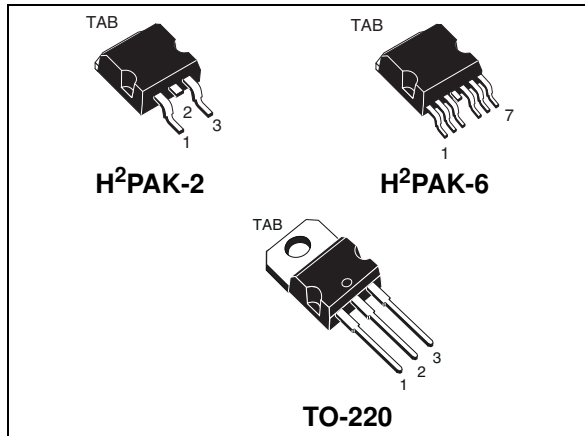
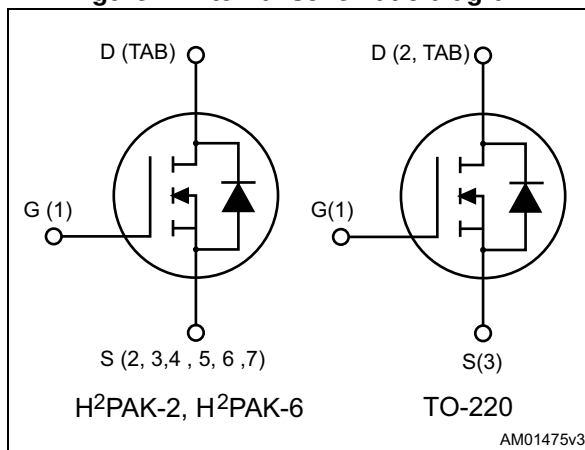

Figure 1. Internal schematic diagram



Features

Order codes	V _{DS}	R _{DS(on)} max	I _D
STH270N8F7-2	80 V	0.0021 Ω	180 A
STH270N8F7-6			
STP270N8F7		0.0025 Ω	

- Among the lowest R_{DS(on)} on the market
- Excellent figure of merit (FoM)
- Low C_{rss}/C_{iss} ratio for EMI immunity
- High avalanche ruggedness

Applications

- Switching applications

Description

These N-channel Power MOSFETs utilize STripFET™ F7 technology with an enhanced trench gate structure that results in very low on-state resistance, while also reducing internal capacitance and gate charge for faster and more efficient switching.

Table 1. Device summary

Order codes	Marking	Package	Packaging
STH270N8F7-2	270N8F7	H ² PAK-2	Tape and reel
STH270N8F7-6		H ² PAK-6	
STP270N8F7		TO-220	Tube

Contents

1	Electrical ratings	3
2	Electrical characteristics	4
3	Electrical characteristics (curves)	6
4	Test circuits	9
5	Package information	10
5.1	H ² PAK-2 package information	11
5.2	H ² PAK-6 package information	14
5.3	TO-220 type A package information	17
6	Packing information	19
7	Revision history	21

1 Electrical ratings

Table 2. Absolute maximum ratings

Symbol	Parameter	Value	Unit
V_{DS}	Drain-source voltage	80	V
V_{GS}	Gate-source voltage	± 20	V
$I_D^{(1)}$	Drain current (continuous)	180	A
$I_D^{(1)}$	Drain current (continuous) at $T_C = 100\text{ }^\circ\text{C}$	180	A
$I_{DM}^{(2)}$	Drain current (pulsed)	720	A
$P_{TOT}^{(3)}$	Total dissipation at $T_C = 25\text{ }^\circ\text{C}$	315	W
$E_{AS}^{(4)}$	Single pulse avalanche energy	1.16	J
T_J	Operating junction temperature	-55 to 175	$^\circ\text{C}$
T_{stg}	Storage temperature		$^\circ\text{C}$

1. Limited by package
2. Pulse width limited by safe operating area
3. This value is rated according to R_{thj-c}
4. Starting $T_j = 25\text{ }^\circ\text{C}$, $I_d = 65\text{ A}$, $V_{dd} = 50\text{ V}$

Table 3. Thermal resistance

Symbol	Parameter	Value		Unit
		H ² PAK-2, H ² PAK-6	TO-220	
$R_{thj-case}$	Thermal resistance junction-case	0.48		$^\circ\text{C}/\text{W}$
$R_{thj-pcb}^{(1)}$	Thermal resistance junction-pcb	35		$^\circ\text{C}/\text{W}$
$R_{thj-amb}$	Thermal resistance junction-ambient max		62.5	$^\circ\text{C}/\text{W}$

1. When mounted on FR-4 board of 1 inch², 2oz Cu

2 Electrical characteristics

($T_{CASE}=25\text{ °C}$ unless otherwise specified)

Table 4. On/off states

Symbol	Parameter	Test conditions	Min.	Typ.	Max.	Unit
$V_{(BR)DSS}$	Drain-source breakdown voltage ($V_{GS}=0$)	$I_D = 250\text{ }\mu\text{A}$	80			V
I_{DSS}	Zero gate voltage drain current ($V_{GS}=0$)	$V_{DS} = 80\text{ V}$ $V_{DS} = 80\text{ V}; T_C=125\text{ °C}$			10 100	μA μA
I_{GSS}	Gate body leakage current ($V_{DS}=0$)	$V_{GS} = +20\text{ V}$			100	nA
$V_{GS(th)}$	Gate threshold voltage	$V_{DS}=V_{GS}, I_D = 250\text{ }\mu\text{A}$	2		4	V
$R_{DS(on)}$	Static drain-source on-resistance	For H ² PAK-2, H ² PAK-6: $V_{GS} = 10\text{ V}, I_D = 90\text{ A}$		0.0017	0.0021	Ω
		For TO-220: $V_{GS} = 10\text{ V}, I_D = 90\text{ A}$		0.0021	0.0025	

Table 5. Dynamic

Symbol	Parameter	Test conditions	Min.	Typ.	Max.	Unit
C_{iss}	Input capacitance	$V_{DS}=50\text{ V}, f=1\text{ MHz},$ $V_{GS}=0$	-	13600	-	pF
C_{oss}	Output capacitance		-	2050	-	pF
C_{rss}	Reverse transfer capacitance		-	236	-	pF
Q_g	Total gate charge	$V_{DD}=40\text{ V}, I_D = 180\text{ A}$ $V_{GS} = 10\text{ V}$ <i>Figure 19</i>	-	193	-	nC
Q_{gs}	Gate-source charge		-	96	-	nC
Q_{gd}	Gate-drain charge		-	46	-	nC

Table 6. Switching times

Symbol	Parameter	Test conditions	Min.	Typ.	Max.	Unit
$t_{d(on)}$	Turn-on delay time	$V_{DD}=40\text{ V}, I_D = 90\text{ A},$ $R_G=4.7\text{ }\Omega, V_{GS} = 10\text{ V}$ <i>Figure 18</i>	-	56	-	ns
t_r	Rise time		-	180	-	ns
$t_{d(off)}$	Turn-off delay time		-	98	-	ns
t_f	Fall time		-	42	-	ns

Table 7. Source drain diode

Symbol	Parameter	Test conditions	Min	Typ.	Max	Unit
I_{SD}	Source-drain current		-		180	A
$I_{SDM}^{(1)}$	Source-drain current (pulsed)		-		720	A
$V_{SD}^{(2)}$	Forward on voltage	$I_{SD} = 90 \text{ A}, V_{GS} = 0$	-		1.2	V
t_{rr}	Reverse recovery time	$I_{SD} = 180 \text{ A},$ $di/dt = 100 \text{ A}/\mu\text{s},$ $V_{DD} = 64 \text{ V}, T_j = 150 \text{ }^\circ\text{C}$	-	78		ns
Q_{rr}	Reverse recovery charge		-	182		nC
I_{RRM}	Reverse recovery current		-	4.7		A

1. Pulse width limited by safe operating area
2. Pulsed: pulse duration=300 μs , duty cycle 1.5%

3 Electrical characteristics (curves)

Figure 2. Safe operating area for H²PAK-2 and H²PAK-6

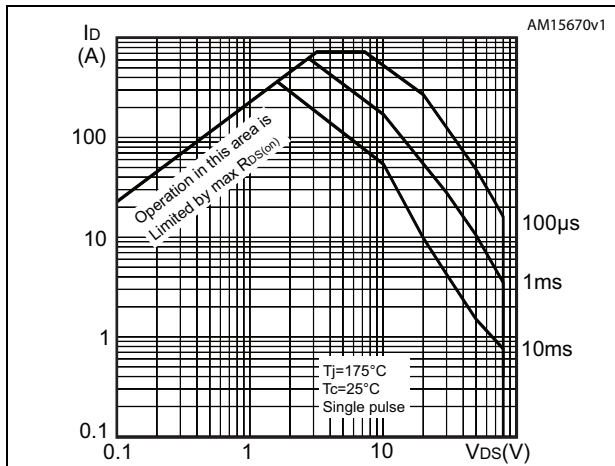

Figure 3. Safe operating area for TO-220

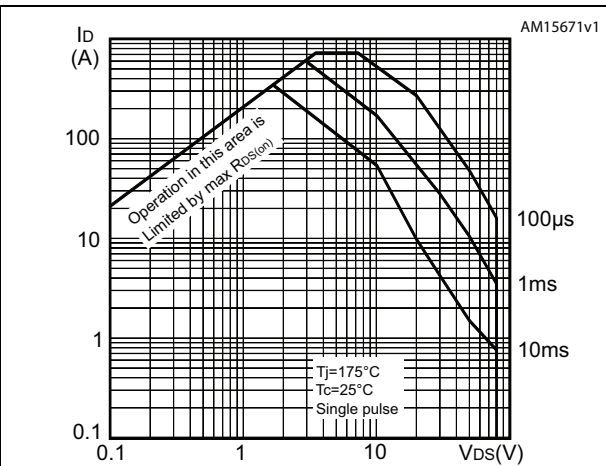

Figure 4. Thermal impedance

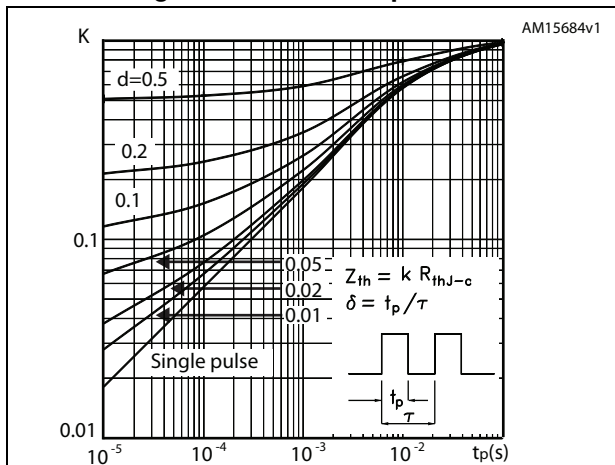

Figure 5. Gate charge vs gate-source voltage

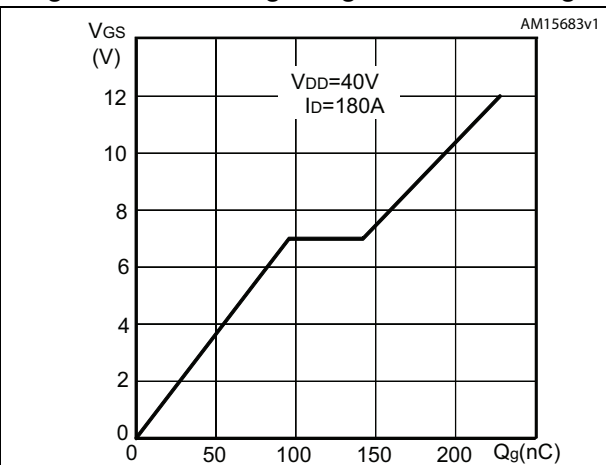

Figure 6. Output characteristics for TO-220

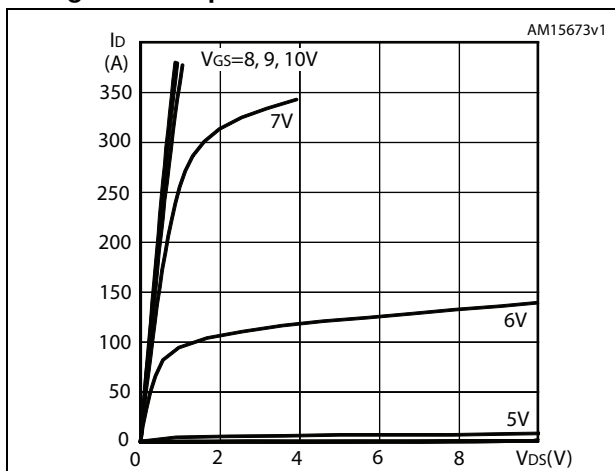

Figure 7. Transfer characteristics for TO-220

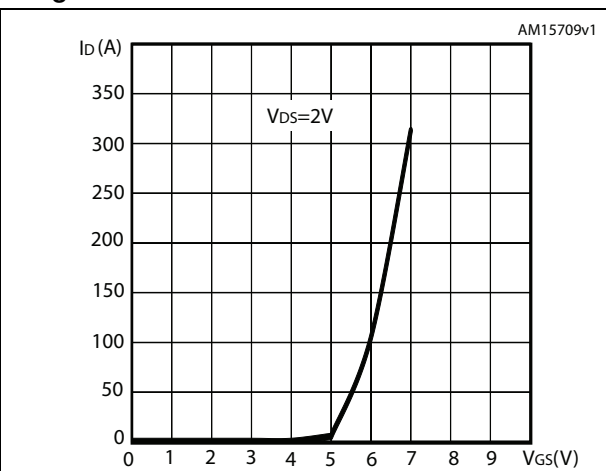

Figure 8. Output characteristics for H²PAK-2 and H²PAK-6

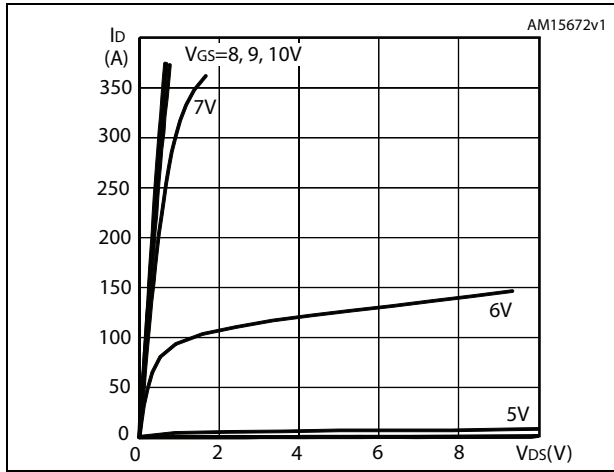

Figure 9. Transfer characteristics for H²PAK-2 and H²PAK-6

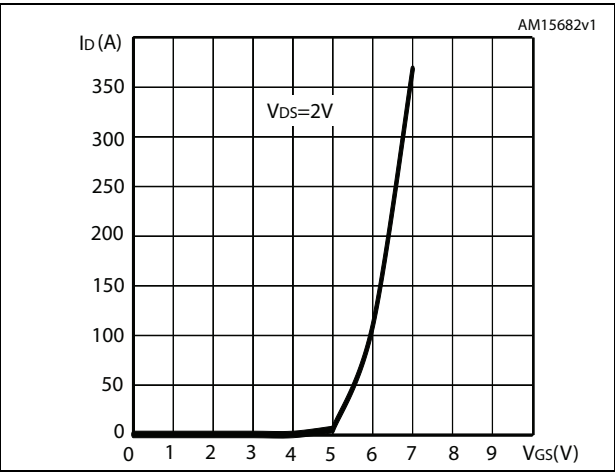

Figure 10. Normalized V_{(BR)DSS} vs temperature

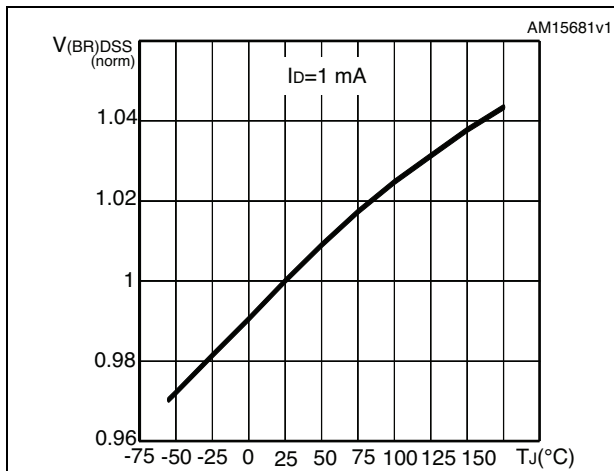

Figure 11. Static drain-source on-resistance for H²PAK-2 and H²PAK-6

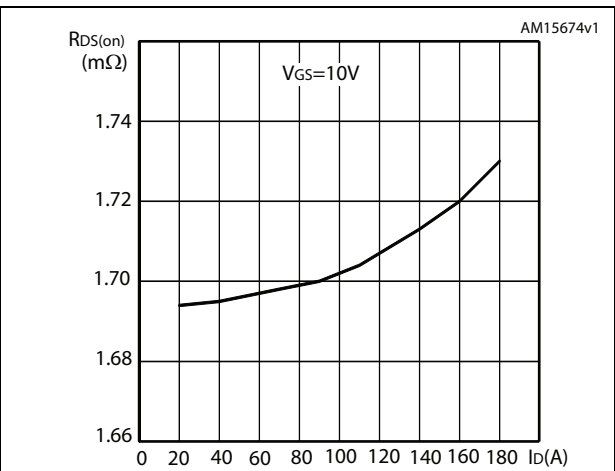

Figure 12. Static drain-source on-resistance for TO-220

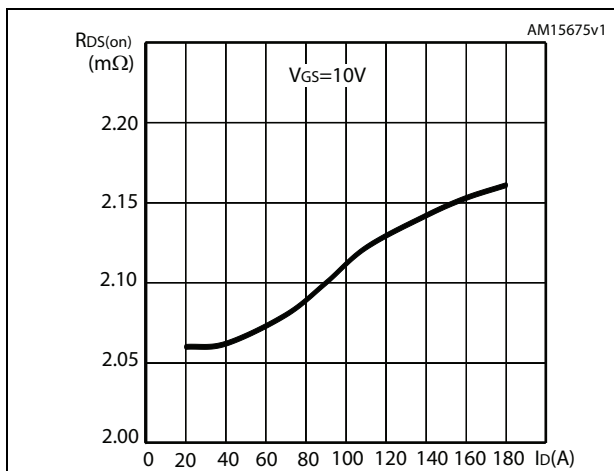

Figure 13. Capacitance variations

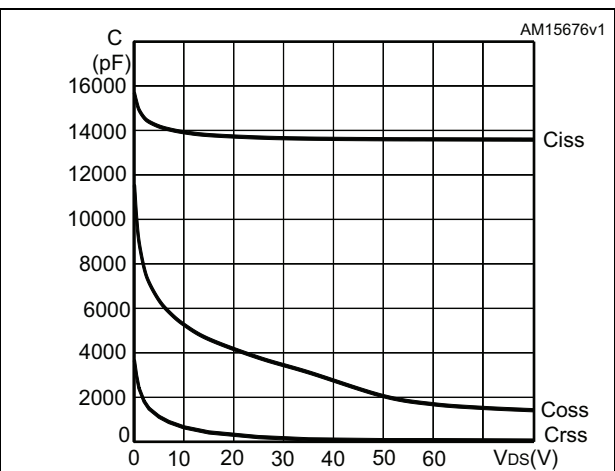

Figure 14. Source-drain diode forward characteristics

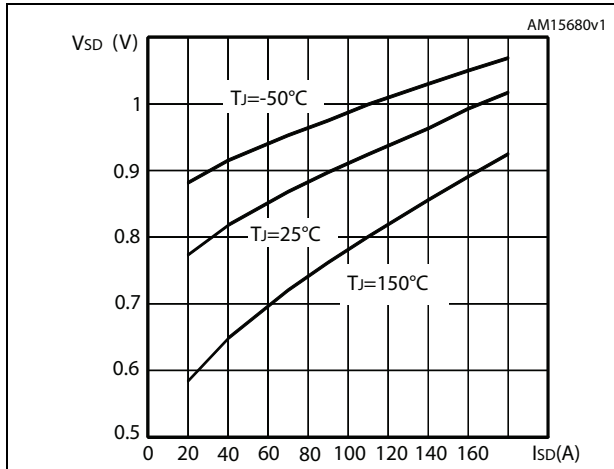

Figure 15. Normalized gate threshold voltage vs temperature

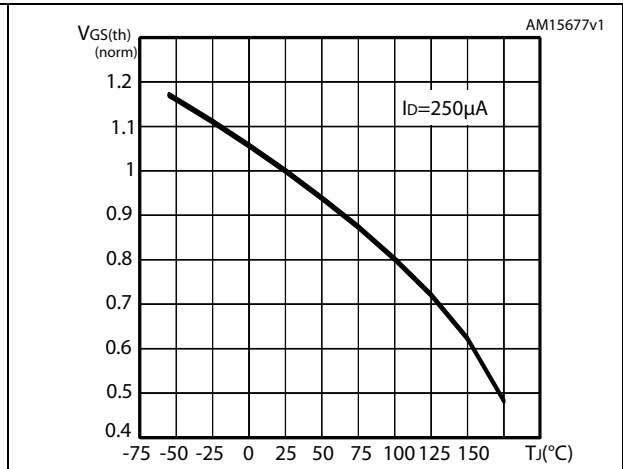

Figure 16. Normalized on-resistance vs temperature for H²PAK-2 and H²PAK-6

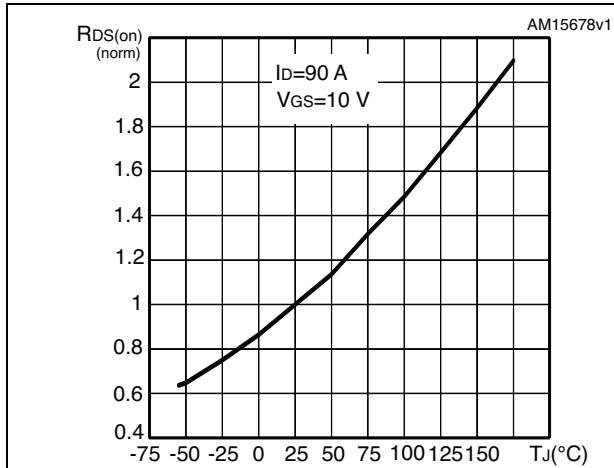
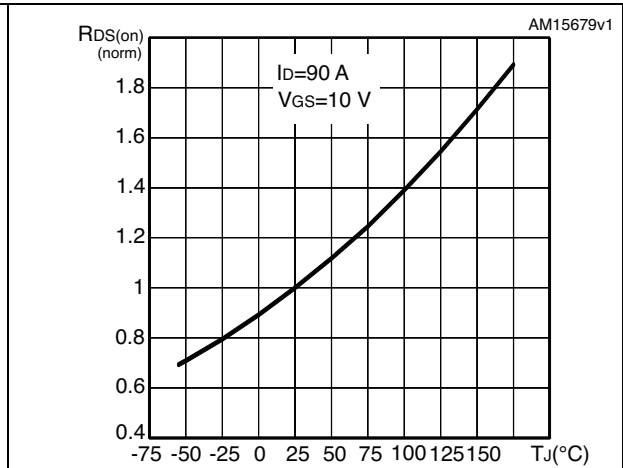
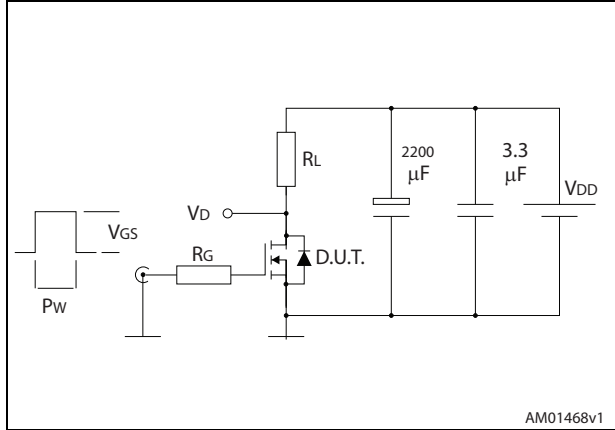

Figure 17. Normalized on-resistance vs temperature for TO-220



4 Test circuits

Figure 18. Switching times test circuit for resistive load



AM01468v1

Figure 19. Gate charge test circuit

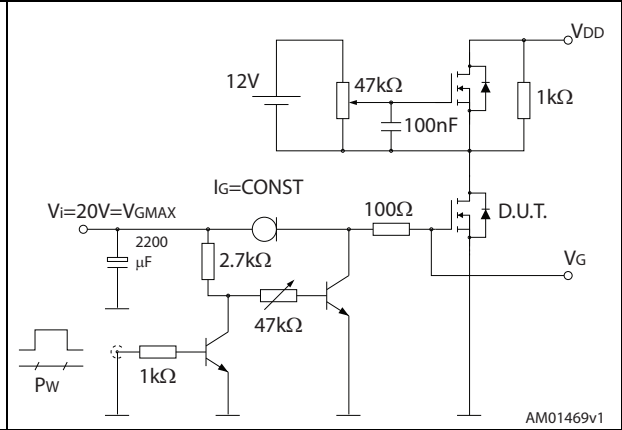

AM01469v1

Figure 20. Test circuit for inductive load switching and diode recovery times

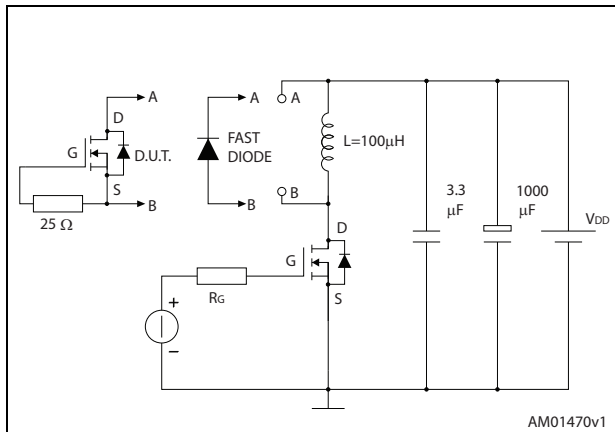

AM01470v1

Figure 21. Unclamped inductive load test circuit

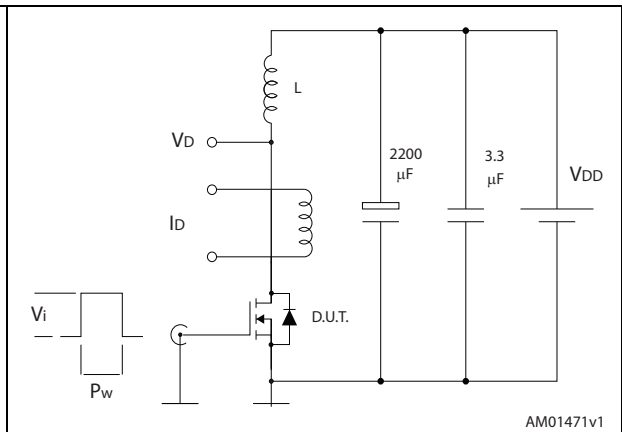

AM01471v1

Figure 22. Unclamped inductive waveform

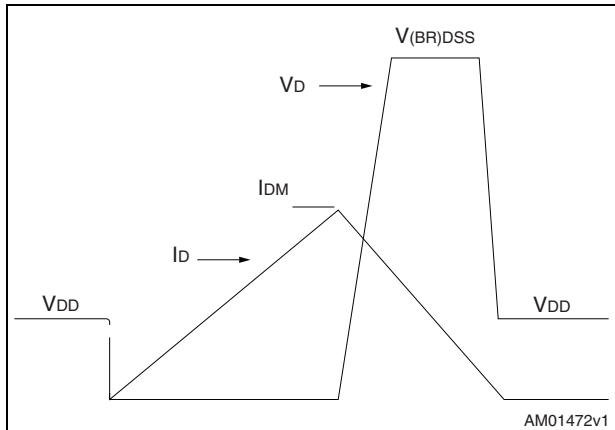

AM01472v1

Figure 23. Switching time waveform

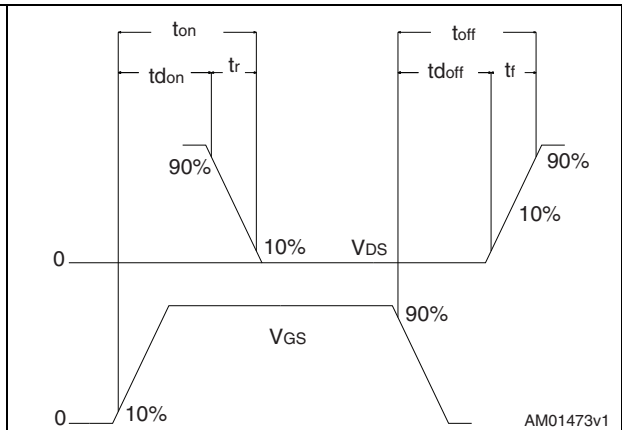

AM01473v1

5 Package information

In order to meet environmental requirements, ST offers these devices in different grades of ECOPACK[®] packages, depending on their level of environmental compliance. ECOPACK[®] specifications, grade definitions and product status are available at: www.st.com. ECOPACK[®] is an ST trademark.

5.1 H²PAK-2 package information

Figure 24. H²PAK-2 package information

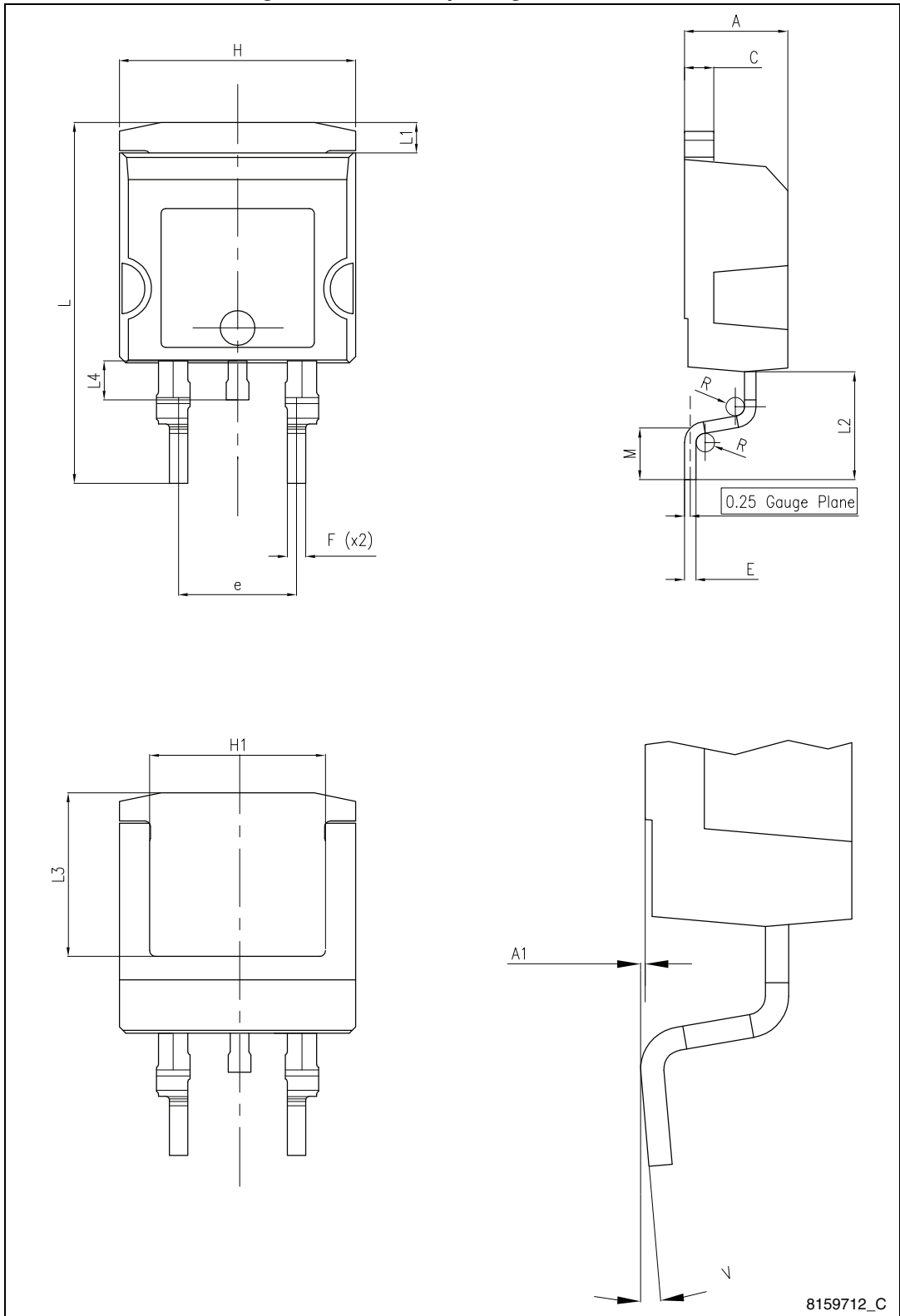

8159712_C

Table 8. H²PAK-2 package mechanical data

Dim.	mm		
	Min.	Typ.	Max.
A	4.30		4.80
A1	0.03		0.20
C	1.17		1.37
e	4.98		5.18
E	0.50		0.90
F	0.78		0.85
H	10.00		10.40
H1	7.40		7.80
L	15.30		15.80
L1	1.27		1.40
L2	4.93		5.23
L3	6.85		7.25
L4	1.5		1.7
M	2.6		2.9
R	0.20		0.60
V	0°		8°

Figure 25. H²PAK-2 recommended footprint (in mm)

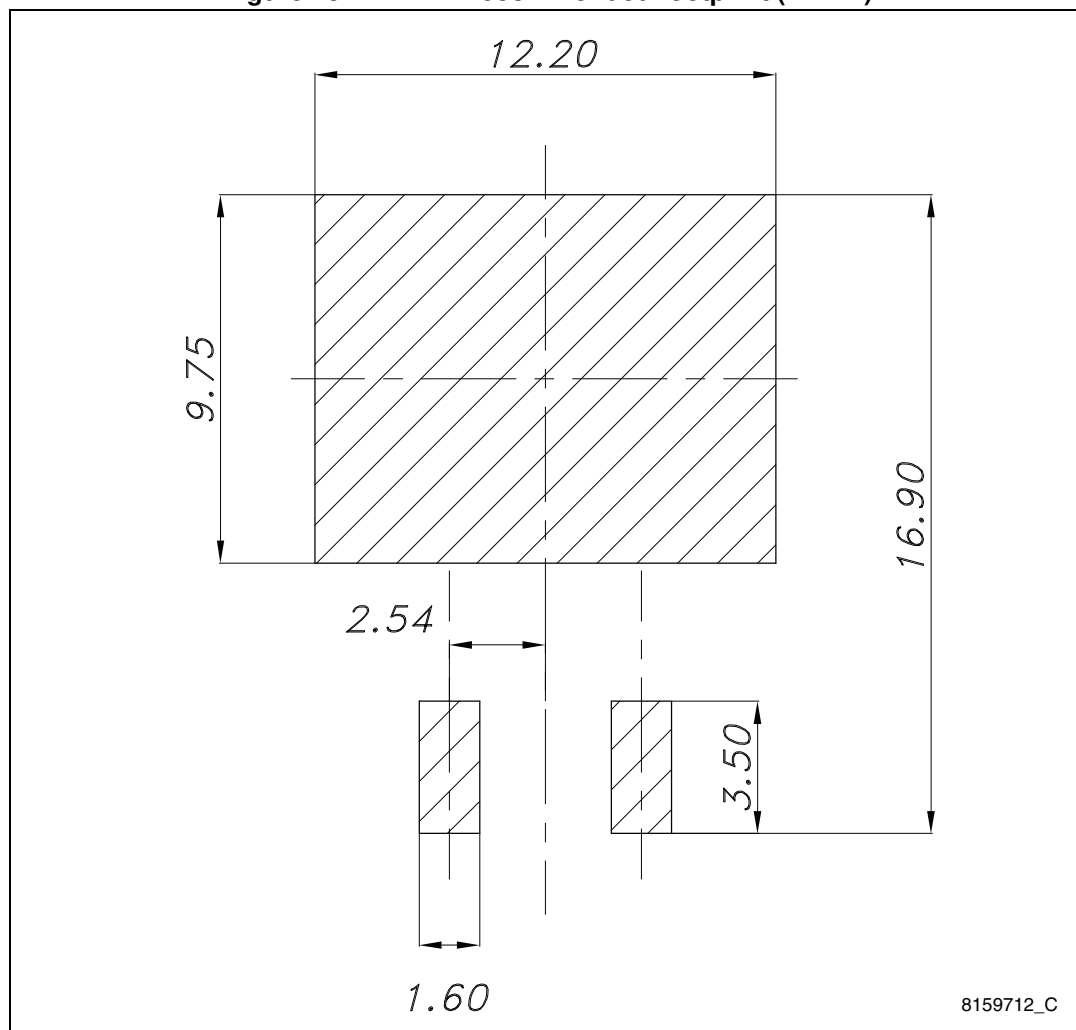

8159712_C

5.2 H²PAK-6 package information

Figure 26. H²PAK-6 package outline

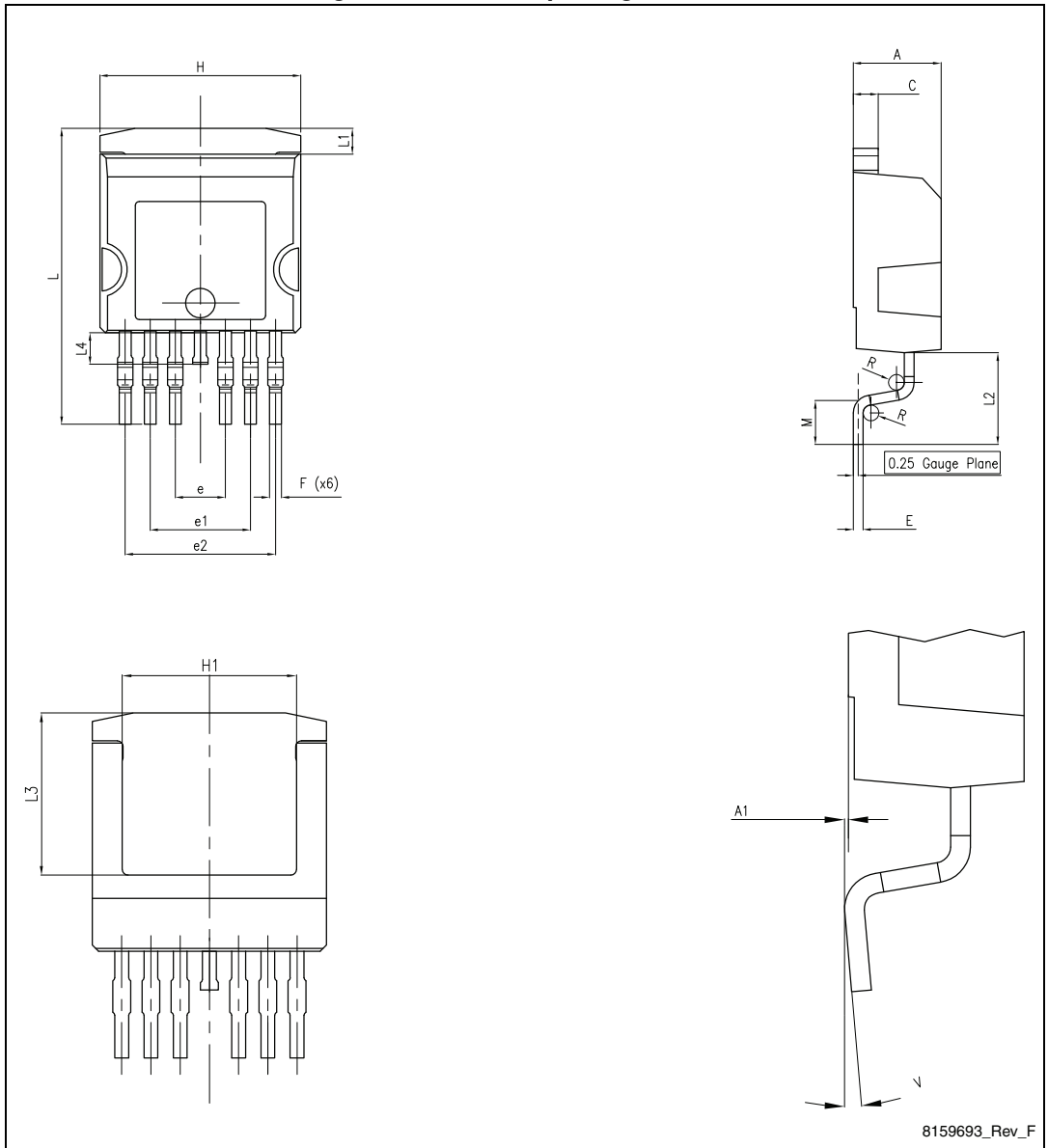

8159693_Rev_F

Table 9. H²PAK-6 package mechanical data

Dim.	mm		
	Min.	Typ.	Max.
A	4.30		4.80
A1	0.03		0.20
C	1.17		1.37
e	2.34		2.74
e1	4.88		5.28
e2	7.42		7.82
E	0.45		0.60
F	0.50		0.70
H	10.00		10.40
H1	7.40		7.80
L	14.75		15.25
L1	1.27		1.40
L2	4.35		4.95
L3	6.85		7.25
L4	1.5		1.75
M	1.90		2.50
R	0.20		0.60
V	0°		8°

Figure 27. H²PAK-6 recommended footprint (dimensions are in mm)

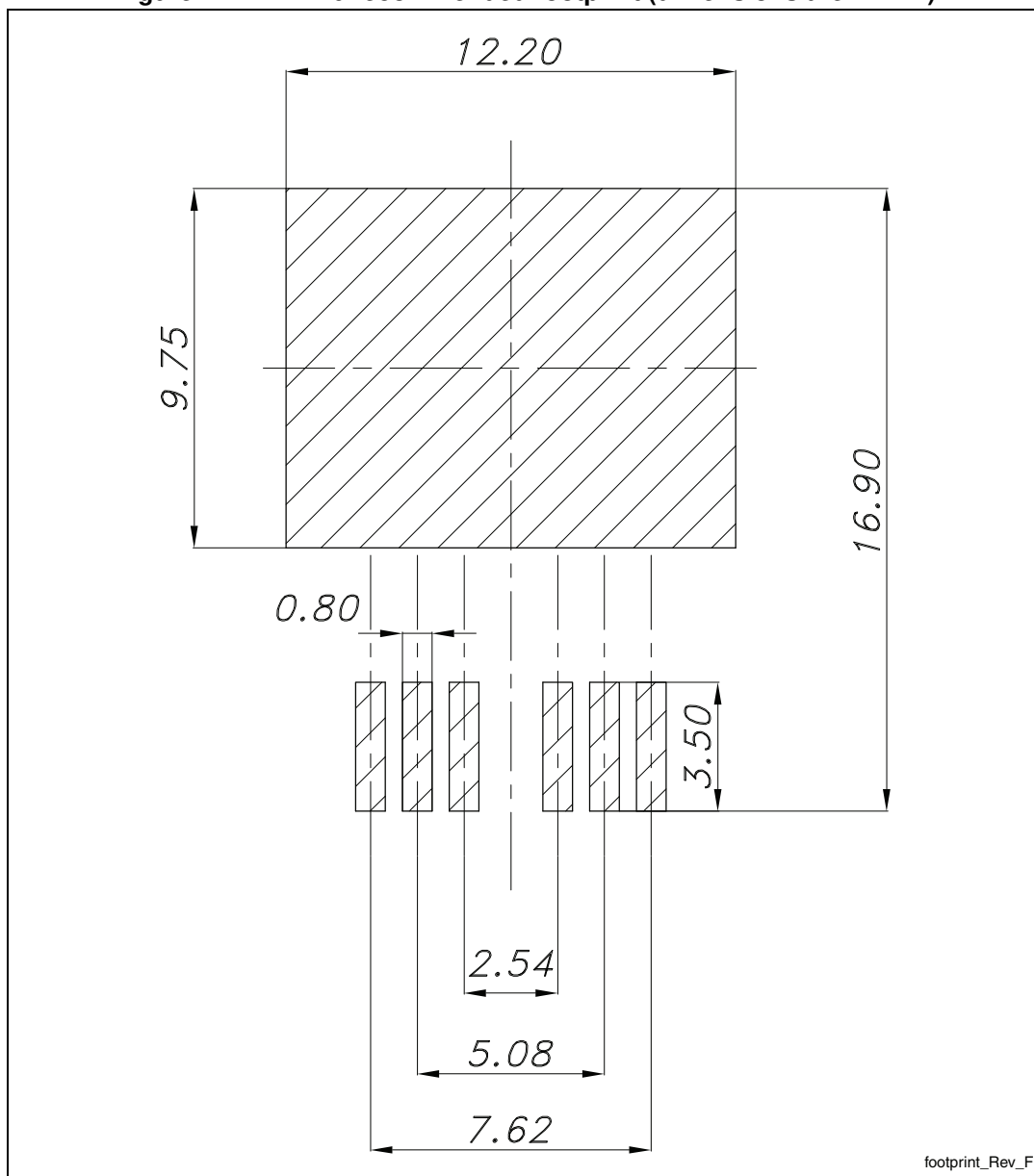

5.3 TO-220 type A package information

Figure 28. TO-220 type A package outline

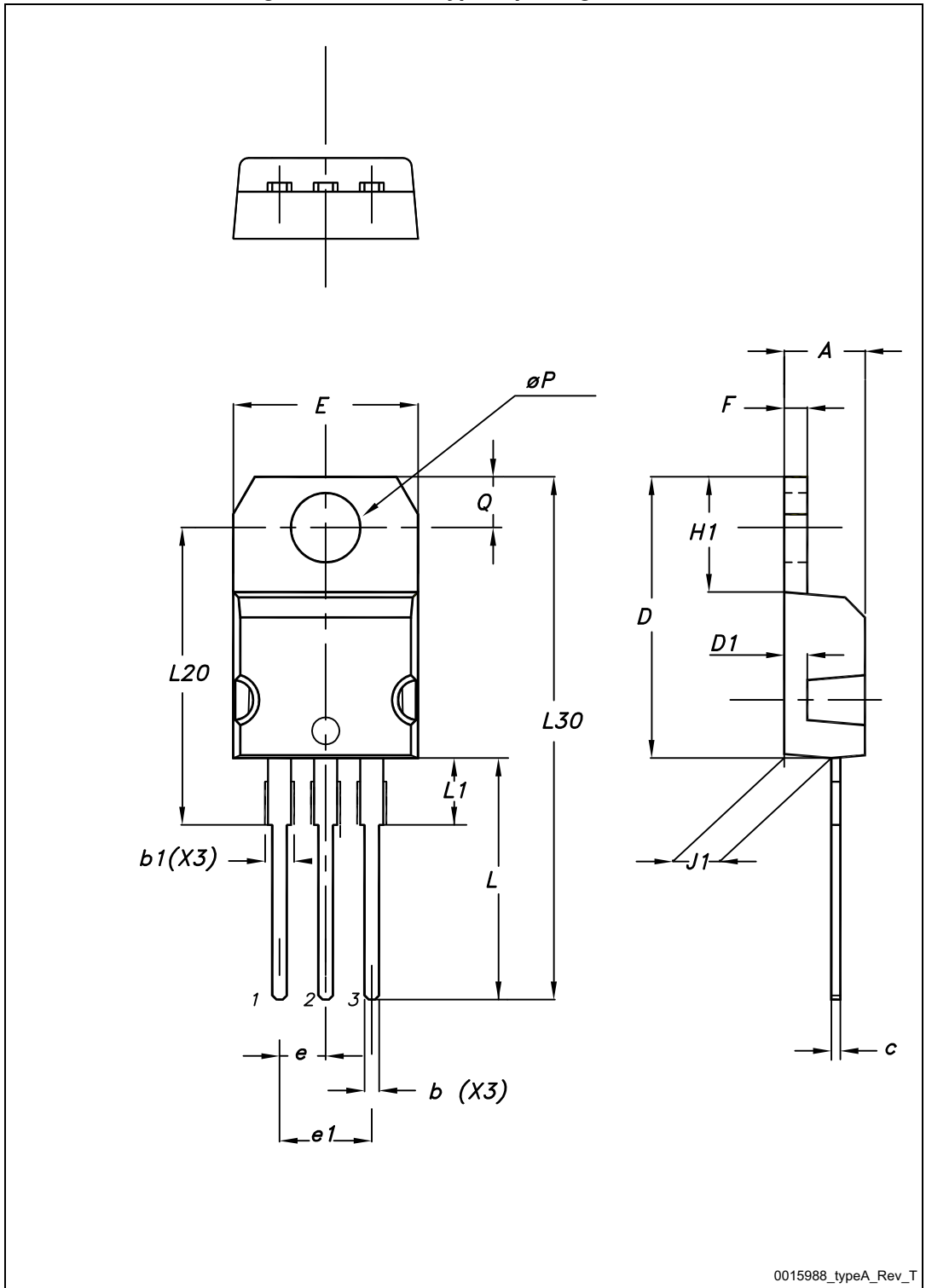

Table 10. TO-220 type A mechanical data

Dim.	mm		
	Min.	Typ.	Max.
A	4.40		4.60
b	0.61		0.88
b1	1.14		1.70
c	0.48		0.70
D	15.25		15.75
D1		1.27	
E	10		10.40
e	2.40		2.70
e1	4.95		5.15
F	1.23		1.32
H1	6.20		6.60
J1	2.40		2.72
L	13		14
L1	3.50		3.93
L20		16.40	
L30		28.90	
ØP	3.75		3.85
Q	2.65		2.95

6 Packing information

Figure 29. Tape

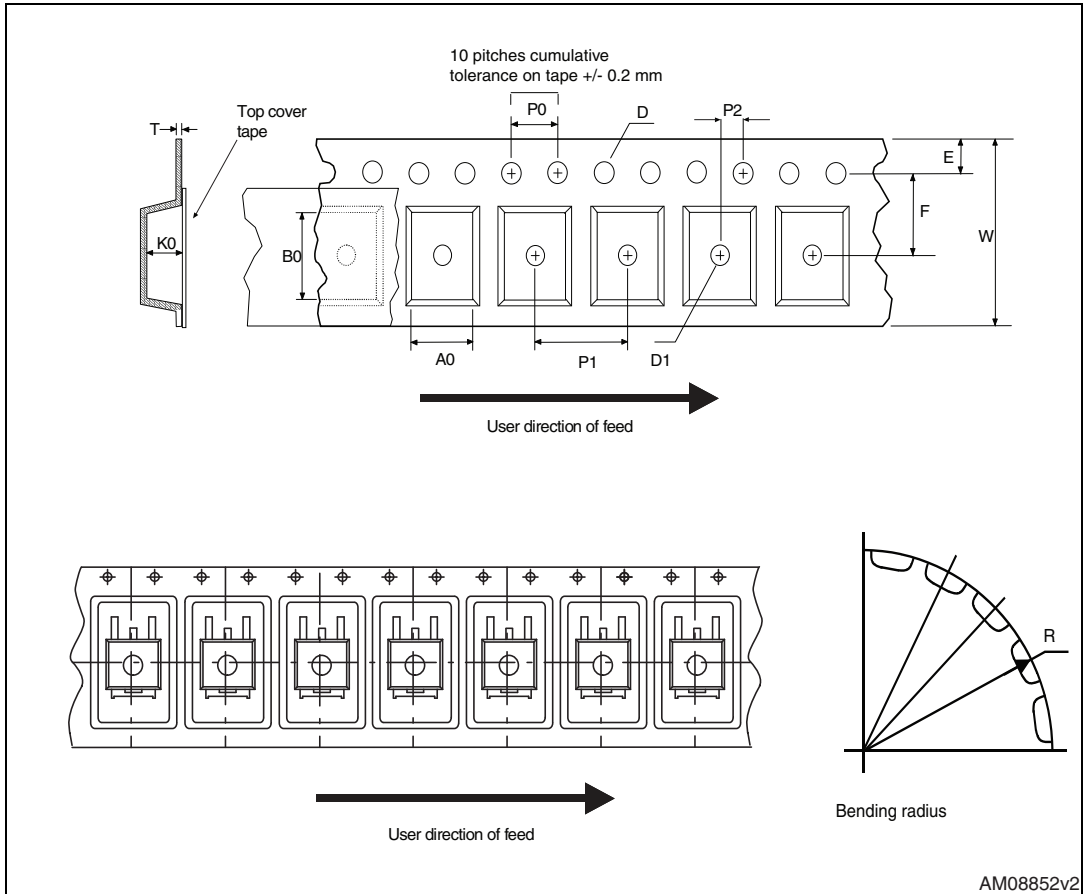

Figure 30. Reel

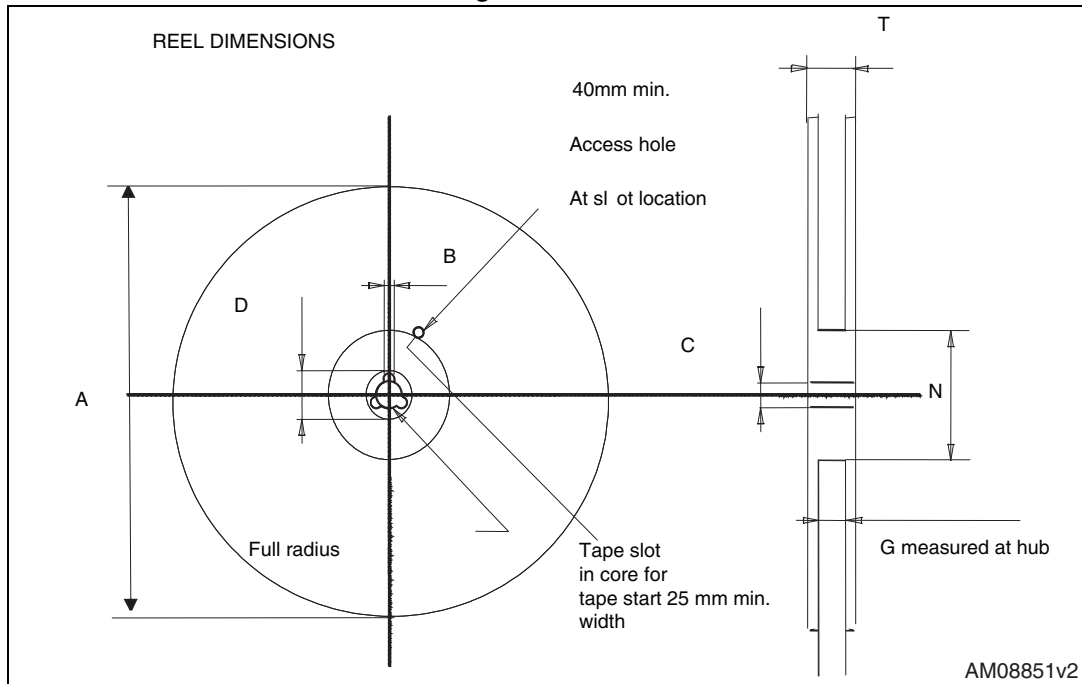

Table 11. H²PAK-2 and H²PAK-6 tape and reel mechanical data

Tape			Reel		
Dim.	mm		Dim.	mm	
	Min.	Max.		Min.	Max.
A0	10.5	10.7	A		330
B0	15.7	15.9	B	1.5	
D	1.5	1.6	C	12.8	13.2
D1	1.59	1.61	D	20.2	
E	1.65	1.85	G	24.4	26.4
F	11.4	11.6	N	100	
K0	4.8	5.0	T		30.4
P0	3.9	4.1			
P1	11.9	12.1		Base qty	1000
P2	1.9	2.1		Bulk qty	1000
R	50				
T	0.25	0.35			
W	23.7	24.3			

7 Revision history

Table 12. Document revision history

Date	Revision	Changes
03-Dec-2012	1	First release.
09-Apr-2013	2	<ul style="list-style-type: none"> – Modified: $R_{DS(on)}$ max values on Features table, I_{DSS}, I_{GSS} values on Table 4, $R_{DS(on)}$ value for H²PAK-2, the entire typical values on Table 5 and 6, V_{SD} test conditions and max values, T_{RR}, Q_{RR}, I_{RRM} typical values on Table 7 – Inserted: Section 3: Electrical characteristics (curves) – Document status promoted to preliminary data to production data – Added: H²PAK-6 package – Minor text changes
11-Oct-2013	3	<ul style="list-style-type: none"> – Modified: C_{rSS} typical value in Table 5 – Updated: Section 5: Package information – Updated: Figure 18, 19, 20 and 21 – Minor text changes
14-May-2015	4	<ul style="list-style-type: none"> – Updated title, features and description in cover page. – Minor text changes

IMPORTANT NOTICE – PLEASE READ CAREFULLY

STMicroelectronics NV and its subsidiaries ("ST") reserve the right to make changes, corrections, enhancements, modifications, and improvements to ST products and/or to this document at any time without notice. Purchasers should obtain the latest relevant information on ST products before placing orders. ST products are sold pursuant to ST's terms and conditions of sale in place at the time of order acknowledgement.

Purchasers are solely responsible for the choice, selection, and use of ST products and ST assumes no liability for application assistance or the design of Purchasers' products.

No license, express or implied, to any intellectual property right is granted by ST herein.

Resale of ST products with provisions different from the information set forth herein shall void any warranty granted by ST for such product.

ST and the ST logo are trademarks of ST. All other product or service names are the property of their respective owners.

Information in this document supersedes and replaces information previously supplied in any prior versions of this document.

© 2015 STMicroelectronics – All rights reserved