



Chipsmall Limited consists of a professional team with an average of over 10 year of expertise in the distribution of electronic components. Based in Hongkong, we have already established firm and mutual-benefit business relationships with customers from,Europe,America and south Asia,supplying obsolete and hard-to-find components to meet their specific needs.

With the principle of “Quality Parts,Customers Priority,Honest Operation,and Considerate Service”,our business mainly focus on the distribution of electronic components. Line cards we deal with include Microchip,ALPS,ROHM,Xilinx,Pulse,ON,Everlight and Freescale. Main products comprise IC,Modules,Potentiometer,IC Socket,Relay,Connector.Our parts cover such applications as commercial,industrial, and automotives areas.

We are looking forward to setting up business relationship with you and hope to provide you with the best service and solution. Let us make a better world for our industry!



Contact us

Tel: +86-755-8981 8866 Fax: +86-755-8427 6832

Email & Skype: info@chipsmall.com Web: www.chipsmall.com

Address: A1208, Overseas Decoration Building, #122 Zhenhua RD., Futian, Shenzhen, China



4 x 50 W MOSFET quad bridge power amplifier

Datasheet - production data

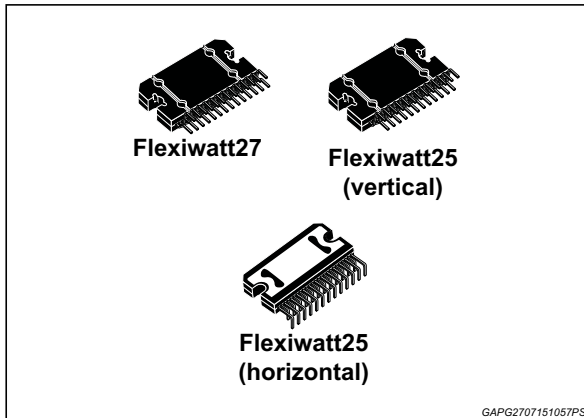

- Overrating chip temperature with soft thermal limiter
- Output DC offset detection
- Load dump
- Fortuitous open GND
- Reversed battery
- ESD
- Qualification in accordance to AEC Q100 standard

Description

STPA008 is a breakthrough MOSFET technology class AB audio power amplifier designed for high power car radio. The fully complementary P-Channel/N-Channel output structure allows a rail to rail output voltage swing which, combined with high output current and minimized saturation losses sets new power references in the car-radio field, with unparalleled distortion performances.

STPA008 can operate down to 6V and this makes the IC compliant to the most recent OEM specifications for low voltage operation (so called 'start-stop' battery profile during engine stop), helping car manufacturers to reduce the overall emissions and thus contributing to environment protection.

Features

- High output power capability:
 - 4 x 50 W/4 Ω Max.
 - 4 x 28 W/4 Ω @ 14.4 V, 1 kHz, 10 %
 - 4 x 72 W/2 Ω Max.
- MOSFET output power stage
- 2 Ω driving capability
- Capable to operate down to 6 V (suitable for start-stop car operation)
- Excellent GSM noise immunity
- Hi-Fi class distortion
- Low output noise
- High immunity to RF noise injection
- Standby function
- Mute function
- Automute at min. supply voltage detection
- Low external component count
- Internally fixed gain (26 dB)
- Protections:
 - Output short circuit to GND, to V_s , across the load
 - Very inductive loads

Table 1. Device summary

Order code	Package	Packing
STPA008-4WX	Flexiwatt25 (vertical)	Tube
STPA008-QIX	Flexiwatt25 (horizontal)	Tube
STPA008-48X	Flexiwatt27	Tube

Contents

- 1 Overview 6**
 - 1.1 Block diagram and application circuit 6
- 2 Pin description 8**
 - 2.1 Pin connection 8
 - 2.2 Pin functions 9
- 3 Electrical specifications 10**
 - 3.1 Absolute maximum ratings 10
 - 3.2 Thermal data 10
 - 3.3 Electrical characteristics 11
 - 3.4 Electrical characteristics curves 13
- 4 General information 16**
 - 4.1 Operation 16
 - 4.2 Battery variations 16
 - 4.2.1 Low voltage operation 16
 - 4.2.2 Cranks 17
 - 4.2.3 Advanced battery management (hybrid vehicles) 18
 - 4.3 Protections 19
 - 4.3.1 Short circuits and open load operation 19
 - 4.3.2 Over-voltage and load dump protection 19
 - 4.3.3 Thermal protection 19
 - 4.4 Warnings 20
 - 4.4.1 DC offset detection (OD pin) 20
 - 4.4.2 Clipping detection and diagnostics (CD-DIAG pin) 20
 - 4.5 Heat sink definition 21
- 5 Package information 22**
 - 5.1 Flexiwatt 27 (vertical) package information 22
 - 5.2 Flexiwatt 25 (vertical) package information 24
 - 5.3 Flexiwatt 25 (horizontal) package information 26

6 **Revision history** **28**

List of tables

Table 1.	Device summary	1
Table 2.	Pin functions	9
Table 3.	Absolute maximum ratings	10
Table 4.	Thermal data	10
Table 5.	Electrical characteristics	11
Table 6.	Flexiwatt 27 (vertical) package mechanical data	22
Table 7.	Flexiwatt 25 (vertical) package mechanical data	24
Table 8.	Flexiwatt 25 (horizontal) package mechanical data	26
Table 9.	Document revision history.	28

List of figures

Figure 1.	Block diagram	6
Figure 2.	Application circuit (STPA008-4WX)	7
Figure 3.	Application circuit (STPA008-48X)	7
Figure 4.	Pin connection (top view)	8
Figure 5.	Quiescent current vs. supply voltage	13
Figure 6.	Output power vs. supply voltage (4 Ω)	13
Figure 7.	Output power vs. supply voltage (2 Ω)	13
Figure 8.	Distortion vs. output power (4 Ω)	13
Figure 9.	Distortion vs. output power (2 Ω)	13
Figure 10.	Distortion vs. frequency (4 Ω)	13
Figure 11.	Distortion vs. frequency (2 Ω)	14
Figure 12.	Distortion vs. output power (4 Ω , $V_S = 6$ V)	14
Figure 13.	Distortion vs. output power (2 Ω , $V_S = 6$ V)	14
Figure 14.	Supply voltage rejection vs. frequency	14
Figure 15.	Crosstalk vs. frequency	14
Figure 16.	Total power dissipation & efficiency vs. P_O (4 Ω , Sine)	14
Figure 17.	Power dissipation vs. average Output Power (4 Ω , audio program simulation)	15
Figure 18.	Power dissipation vs. average Output Power (2 Ω , audio program simulation)	15
Figure 19.	ITU R-ARM frequency response, weighting filter for transient pop.	15
Figure 20.	SVR charge diagram.	16
Figure 21.	Battery cranking curve example 1.	17
Figure 22.	Battery cranking curve example 2.	17
Figure 23.	Upwards fast battery transitions diagram	18
Figure 24.	Load dump protection diagram	19
Figure 25.	Thermal protection diagram	19
Figure 26.	Audio section waveforms	20
Figure 27.	Flexiwatt 27 (vertical) package outline	22
Figure 28.	Flexiwatt 25 (vertical) package outline	24
Figure 29.	Flexiwatt 25 (horizontal) package outline	26

1 Overview

STPA008 is a complementary quad audio power amplifier. It is available in two different packages, Flexiwatt25 and Flexiwatt27. It embeds four independent amplifiers working in class AB, a standby and a mute pin, an offset detector and, only for the Flexiwatt27 package, a clipping detector and diagnostics output. The amplifier is fully operational down to a battery voltage of 6 V, without producing pop noise and continuing to play during battery transitions.

STPA008 can drive 2 ohm loads and has a very high immunity to disturbs without need of external components or compensation. It is protected against any kind of short or open circuit, over-voltage and over-temperature.

1.1 Block diagram and application circuit

Figure 1. Block diagram

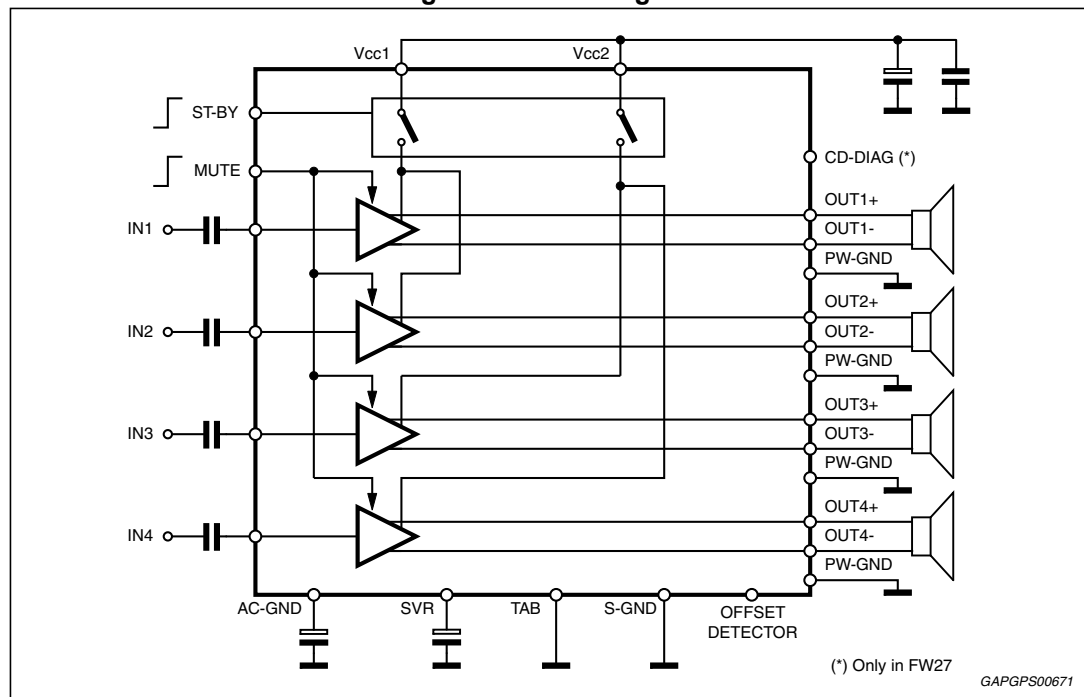

Figure 2. Application circuit (STPA008-4WX)

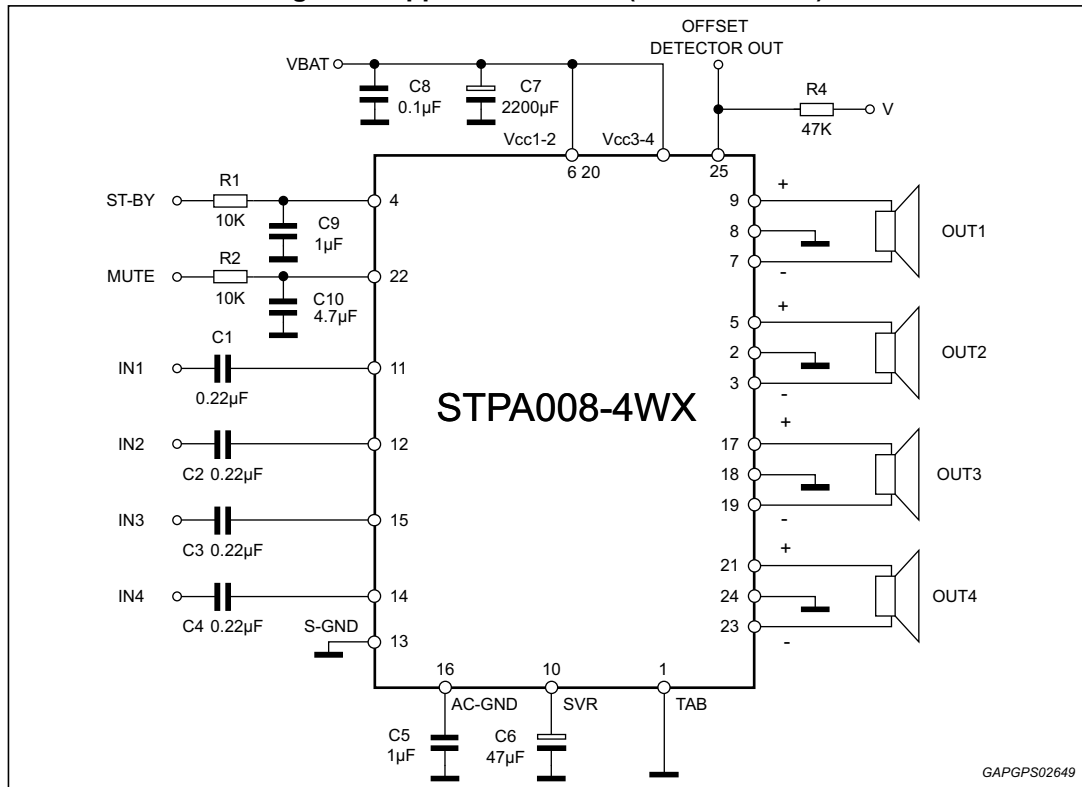
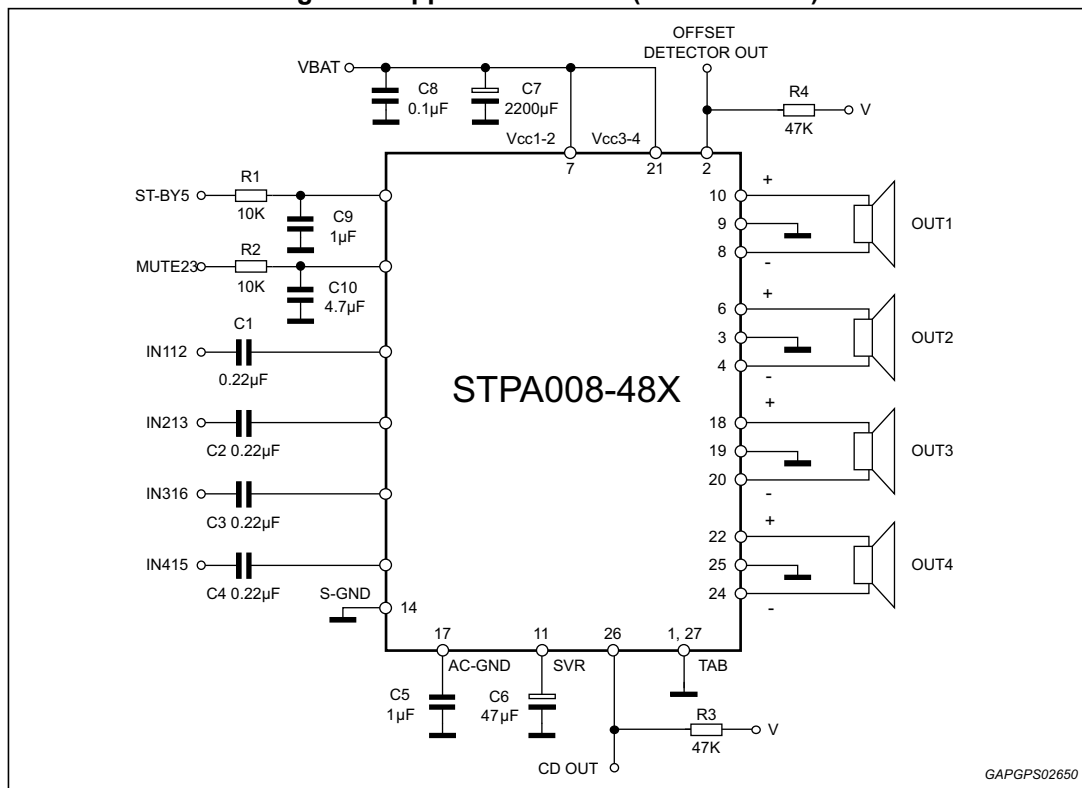

Figure 3. Application circuit (STPA008-48X)



2.2 Pin functions

Table 2. Pin functions

Pin number FW27	Pin number FW25	Pin name	Description
1	1	TAB	Device slug connection
2	25	OD	Offset detector output
3	2	PW-GND2	Channel 2, power ground
4	3	OUT2-	Channel 2, negative output
5	4	ST-BY	Stand-by
6	5	OUT2+	Channel 2, positive output
7	6	VCC	Supply voltage
8	7	OUT1-	Channel 1, negative output
9	8	PW-GND1	Channel 1, power ground
10	9	OUT1+	Channel 1, positive output
11	10	SVR	Supply voltage rejection pin
12	11	IN1	Channel 1, input
13	12	IN2	Channel 2, input
14	13	S-GND	Signal ground
15	14	IN4	Channel 4, input
16	15	IN3	Channel 3, input
17	16	AC-GND	AC ground
18	17	OUT3+	Channel 3, positive output
19	18	PW-GND3	Channel 3, power ground
20	19	OUT3-	Channel 3, negative output
21	20	VCC	Supply voltage
22	21	OUT4+	Channel 4, positive output
23	22	MUTE	Mute pin
24	23	OUT4-	Channel 4, negative output
25	24	PW-GND4	Channel 4, power ground
26	n.a	CD-DIAG	Clipping detector and diagnostics output
27	n.a	TAB	Device slug connection

3 Electrical specifications

3.1 Absolute maximum ratings

Table 3. Absolute maximum ratings

Symbol	Parameter	Value	Unit
V_S	Operating supply voltage	18	V
$V_{S(DC)}$	DC supply voltage	28	V
$V_{S(pk)}$	Peak supply voltage (for $t = 50$ ms)	50	V
I_O	Output peak current Non repetitive ($t = 100$ μ s)	10	A
	Repetitive (duty cycle 10 % at $f = 10$ Hz)	9	A
P_{tot}	Power dissipation $T_{case} = 70$ °C	85	W
T_j	Junction temperature	150	°C
T_{stg}	Storage temperature	-55 to 150	°C
GND_{max}	Ground pins voltage	-0.3 to 0.3	V
$V_{in max}$	Input pin max voltage	-0.3 to 8	V
$V_{SB max}$	ST-BY pin max voltage	-0.3 to $V_{S(pk)}$	V
$V_{mute max}$	Mute pin max voltage	-0.3 to 6	V

3.2 Thermal data

Table 4. Thermal data

Symbol	Parameter	Value	Unit
$R_{th j-case}$	Thermal resistance junction-to-case	Max 1	°C/W

3.3 Electrical characteristics

Refer to the test and application diagram, $V_S = 14.4\text{ V}$; $R_L = 4\ \Omega$; $R_g = 600\ \Omega$; $f = 1\text{ kHz}$; $T_{\text{amb}} = 25\text{ }^\circ\text{C}$; unless otherwise specified.

Table 5. Electrical characteristics

Symbol	Parameter	Test condition	Min.	Typ.	Max.	Unit
General characteristics						
V_S	Supply voltage range	-	6	-	18	V
I_{q1}	Quiescent current	$R_L = \infty$	100	190	280	mA
V_{OS}	Output offset voltage	Play mode	-90	-	+90	mV
		Mute mode	-70	-	+70	mV
dV_{OS}	During standby ON/OFF output transient voltage	ITU R-ARM weighted (see Figure 19)	-7.5	-	+7.5	mV
	During mute ON/OFF output transient voltage		-7.5	-	+7.5	mV
R_i	Input impedance	-	45	55	65	k Ω
I_{SB}	Standby current consumption	$V_{\text{St-by}} = 1\text{ V}$	-	-	2	μA
		$V_{\text{St-by}} = 0$	-	-	1	μA
Audio performances						
P_o	Output power	THD = 10 %	26	29	-	W
		THD = 1 %	20	23	-	W
		THD = 10 %, 2 Ω	45	50	-	W
		THD = 1 %, 2 Ω	37	40	-	W
$P_{o\text{ max.}}$	Max. output power	Square wave input (2 Vrms)				
		$R_L = 4\ \Omega$	42	45	-	W
		$R_L = 2\ \Omega$	71	77	-	W
		$V_S = 15.2\text{ V}$; $R_L = 4\ \Omega$	47	50	-	W
THD	Distortion	$P_o = 4\text{ W}$, 30kHz LPF	-	0.01	0.02	%
G_v	Voltage gain	-	25	26	27	dB
dG_v	Channel gain unbalance	-	-0.5	-	+0.5	dB
e_{No}	Output Noise	"A" Weighted	-	40	-	μV
		Bw = 20 Hz to 20 kHz	-	50	70	μV
SVR	Supply voltage rejection	$f = 100\text{ kHz}$; $V_r = 1\text{ Vrms}$, play mode	60	70	-	dB
f_{ch}	High cut-off frequency	$P_o = 0.5\text{ W}$	100	300	-	kHz
C_T	Cross talk	$f = 1\text{ kHz}$ $P_o = 4\text{ W}$	65	75	-	dB
		$f = 10\text{ kHz}$ $P_o = 4\text{ W}$	50	60	-	dB
A_M	Mute attenuation	$P_{\text{Oref}} = 4\text{ W}$	90	100	-	dB

Table 5. Electrical characteristics (continued)

Symbol	Parameter	Test condition	Min.	Typ.	Max.	Unit
Control pin characteristics						
I_{pin5}	Standby pin current	$V_{St-by} = 1\text{ V to }2.2\text{ V}$	-	-	0.5	μA
$V_{SB\ out}$	Standby out threshold voltage	(Amp: ON)	2.2	-	-	V
$V_{SB\ in}$	Standby in threshold voltage	(Amp: OFF)	-	-	1	V
$V_{M\ out}$	Mute out threshold voltage	(Amp: Play)	2.2	-	-	V
$V_{M\ in}$	Mute in threshold voltage	(Amp: Mute)	-	-	0.8	V
$V_{AM\ in}$	V_S automute threshold	Attenuation = 6 dB; $P_{Oref} = 4\text{ W}$	4.5	5	5.5	V
I_{pin23}	Muting pin current	$V_{MUTE} = 0.8\text{ V}$ (Sourced current)	5	8	12	μA
Offset detector						
V_{OFF}	Detected differential output offset	-	± 1.3	± 2	± 2.7	V
V_{OFF_SAT}	Off detector saturation voltage	$V_o > V_{OFF\ max}$, $I_{off\ Det} = 1\text{ mA}$ $0\text{ V} < V_{off\ Det} < 18\text{ V}$	-	0.1	0.2	V
V_{OFF_LK}	Off detector leakage current	$V_o < \pm 1\text{ V}$	-	0	15	μA
Clipping detector						
CD_{LK}	Clip detector high leakage current	CD Off	-	0	1	μA
CD_{SAT}	Clip detector saturation voltage	CD On; $I_{CD} = 1\text{ mA}$	-	0.1	0.2	V
CD_{THD}	Clip detector THD level	-	-	2	3	%

3.4 Electrical characteristics curves

Figure 5. Quiescent current vs. supply voltage

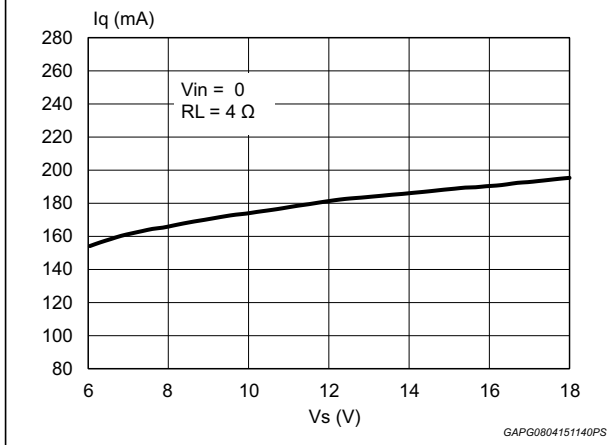

Figure 6. Output power vs. supply voltage (4 Ohm)

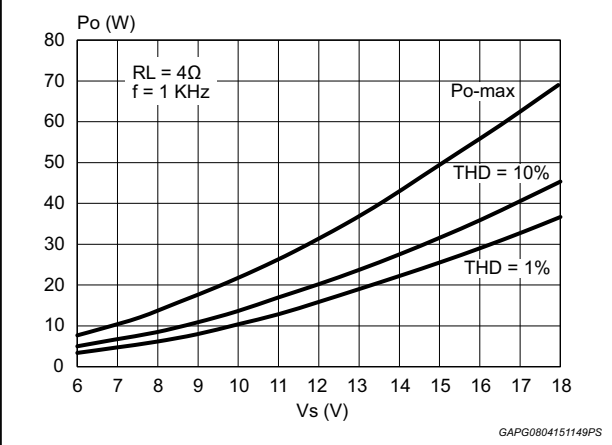

Figure 7. Output power vs. supply voltage (2 Ohm)

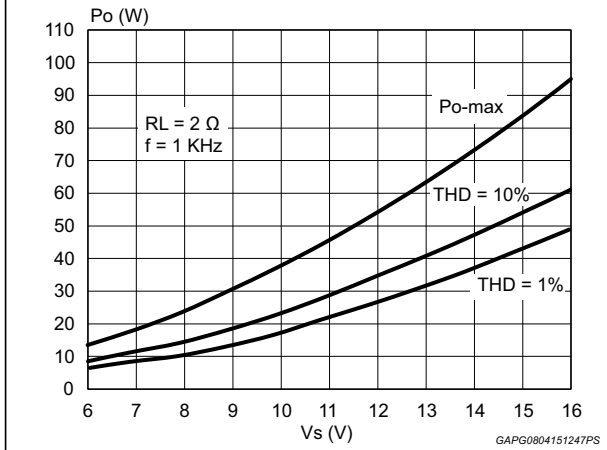

Figure 8. Distortion vs. output power (4 Ohm)

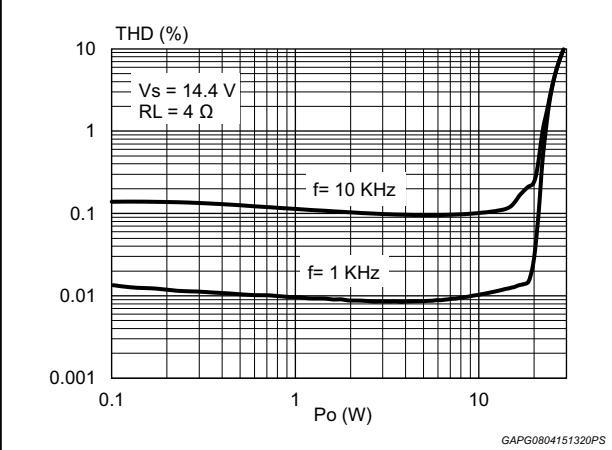

Figure 9. Distortion vs. output power (2 Ohm)

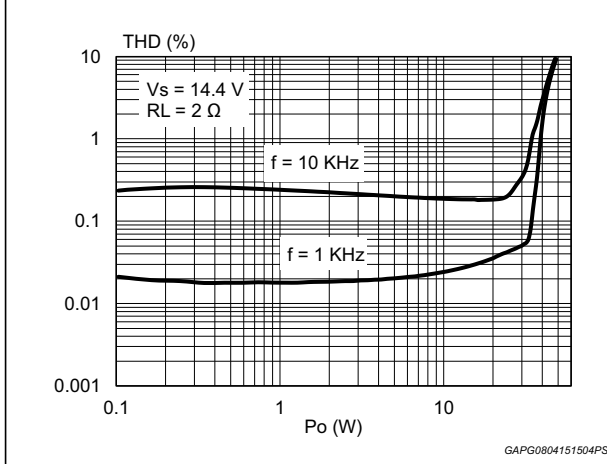

Figure 10. Distortion vs. frequency (4 Ohm)

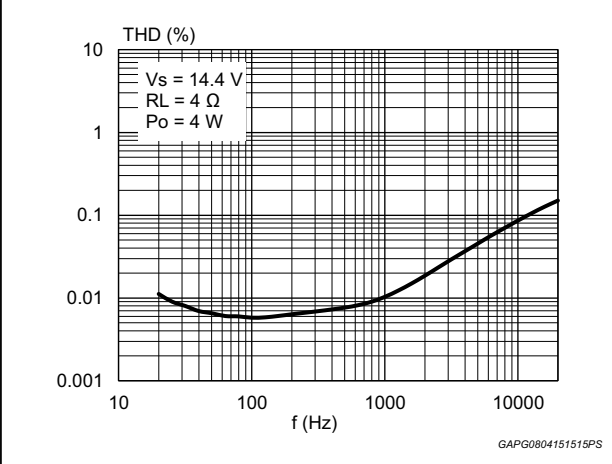

Figure 11. Distortion vs. frequency (2 Ω)

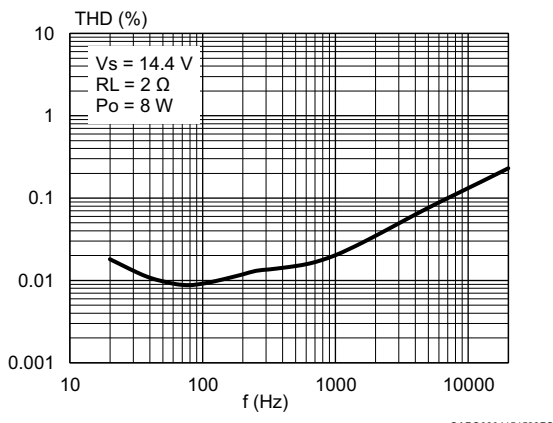

Figure 12. Distortion vs. output power (4 Ω, $V_S = 6\text{ V}$)

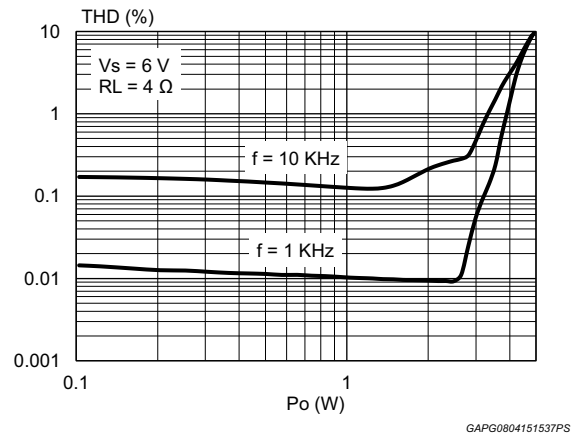

Figure 13. Distortion vs. output power (2 Ω, $V_S = 6\text{ V}$)

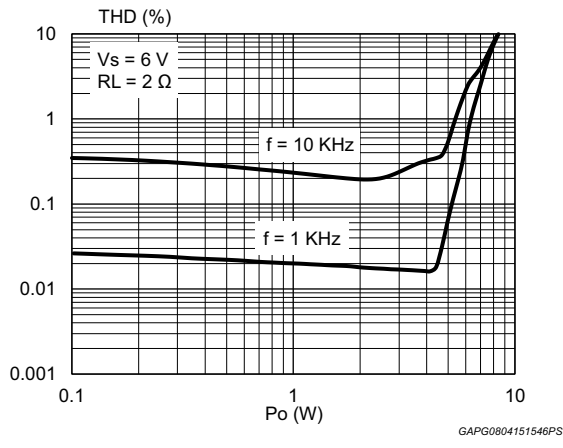

Figure 14. Supply voltage rejection vs. frequency

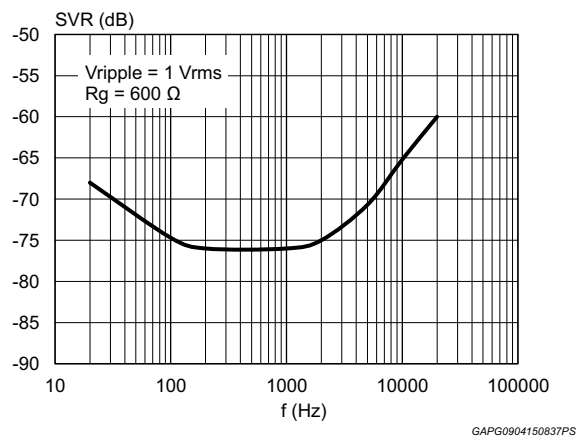

Figure 15. Crosstalk vs. frequency

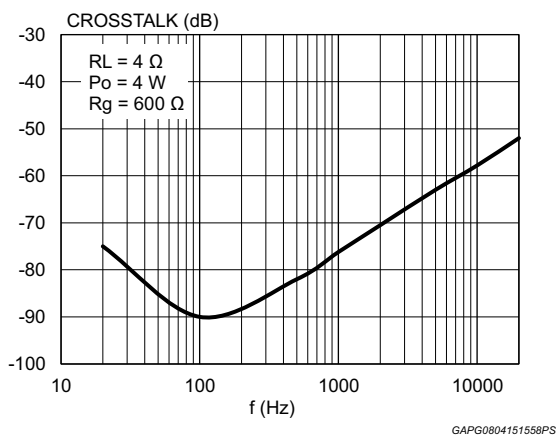

Figure 16. Total power dissipation & efficiency vs. P_o (4 Ω, Sine)

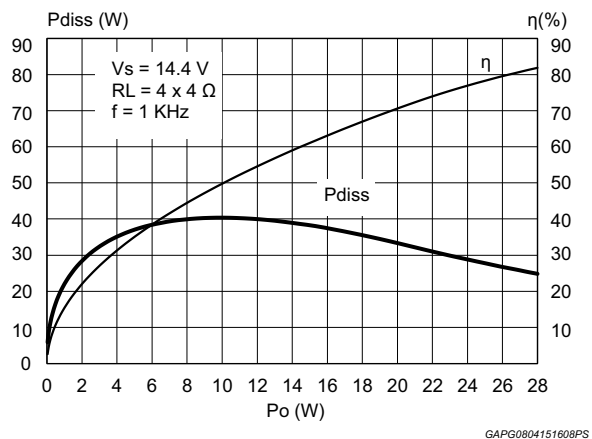
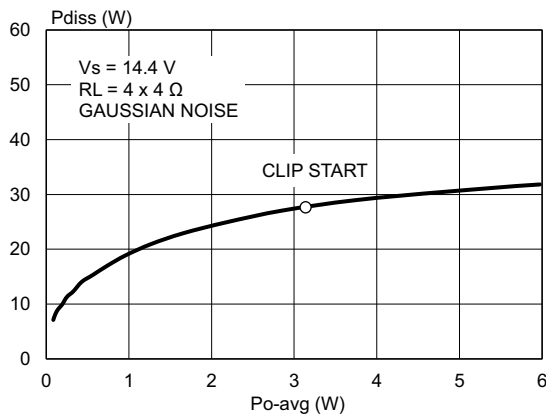
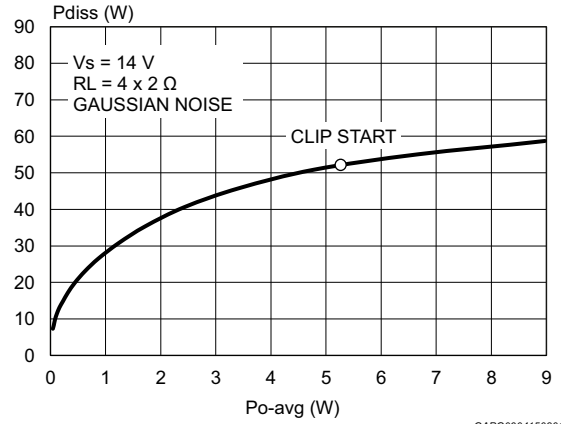

Figure 17. Power dissipation vs. average Output Power (4 Ω, audio program simulation)



GAPG0904150748PS

Figure 18. Power dissipation vs. average Output Power (2 Ω, audio program simulation)



GAPG0904150801PS

Figure 19. ITU R-ARM frequency response, weighting filter for transient pop

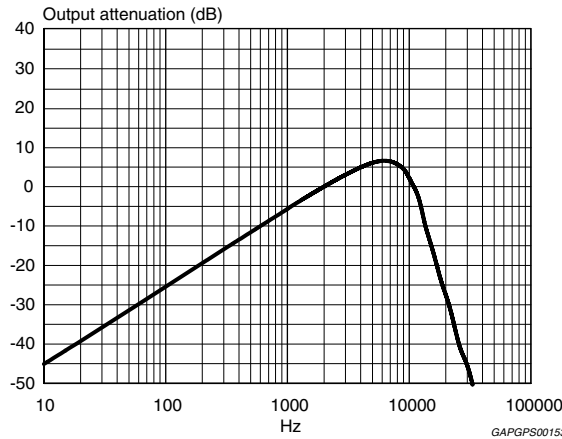

GAPGPS00153

4 General information

4.1 Operation

STPA008's inputs are ground-compatible. If the standard value for the input capacitors (0.22 μF) is adopted, the low frequency cut-off is 16 Hz. The input capacitors should be 1/4 of the capacitor connected to AC-GND pin for optimum pop performances (see [Figure 2: Application circuit \(STPA008-4WX\)](#)).

Standby and mute pins are both 3.3 V CMOS compatible.

RC cells at both mute and stand-by pins have always to be used in order to smooth the transitions for preventing any audible transient noise.

In case the stand-by function is not used, it could steadily be connected to V_S , but a 470 kohm resistance should be present between the power supply and the pin.

The capacitance on SVR sets the start-up and shut-down times and helps to have pop-noise free transitions. Its minimum recommended value is 10 μF . To have a fast start-up time, the internal resistor on SVR pin, used to set the time constant, is reduced from 50 k Ω to 3 k Ω till voltage on SVR reaches $V_{CC}/4 - 2V_{BE}$ and then released. In this way the capacitor on SVR is charged very quickly to $V_{CC}/4$, as shown in the following figure.

The time constant to be assigned to the standby pin in order to obtain a virtually pop-free transition has to be slower than 2.5 V/ms.

Figure 20. SVR charge diagram

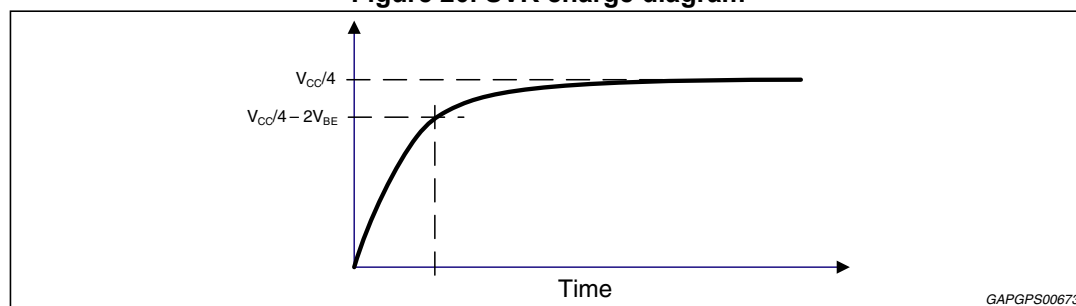

SVR pin accomplishes multiple functions:

- it is used as a reference voltage for input pins ($V_{CC}/4$)
- the capacitor connected to SVR improves the supply voltage ripple rejection
- it is used as a reference to generate the $V_{CC}/2$ reference for the outputs

When the amplifier goes in standby mode or goes out from this condition, it is recommended to put the amplifier in mute to ensure the absence of audible noise. Then the stand-by pin can be set to the appropriate value (ground or > 2.6 V) and the capacitor on SVR pin is discharged or charged consequently.

4.2 Battery variations

4.2.1 Low voltage operation

The most recent OEM specifications require automatic stop of car engine at traffic lights, in order to reduce emissions of polluting substances. STPA008, thanks to its innovating

design, allows a continuous operation when battery falls down. At 6 V it is still fully operational, only the maximum output power is reduced according to the available voltage supply.

If the battery voltage drops below the minimum operating voltage of 6V the amplifier is fast muted, the capacitor on SVR is discharged and the amplifier restarts when the battery voltage returns to the correct voltage.

4.2.2 Cranks

STPA008 can sustain worst case cranks from 16 V to 6 V, continuing to play and without producing any pop noise.

Examples of battery cranking curves are shown below, indicating the shape and duration of allowed battery transitions.

Figure 21. Battery cranking curve example 1

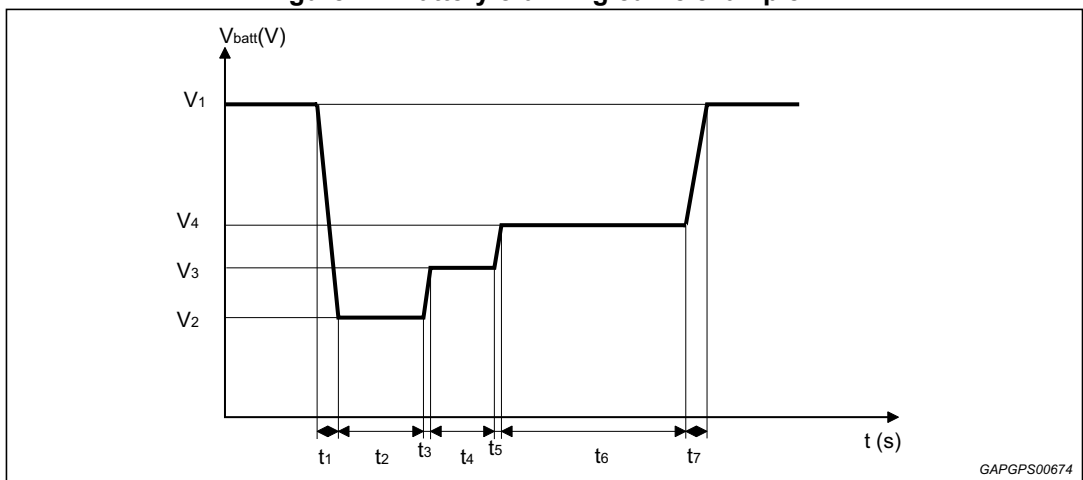

V1 = 16 V; V2 = 6 V; V3 = 7 V; V4 = 8 V

t1 = 2 ms; t2 = 50 ms; t3 = 5 ms; t4 = 300 ms; t5 = 10 ms; t6 = 1 s; t7 = 2 ms

Figure 22. Battery cranking curve example 2

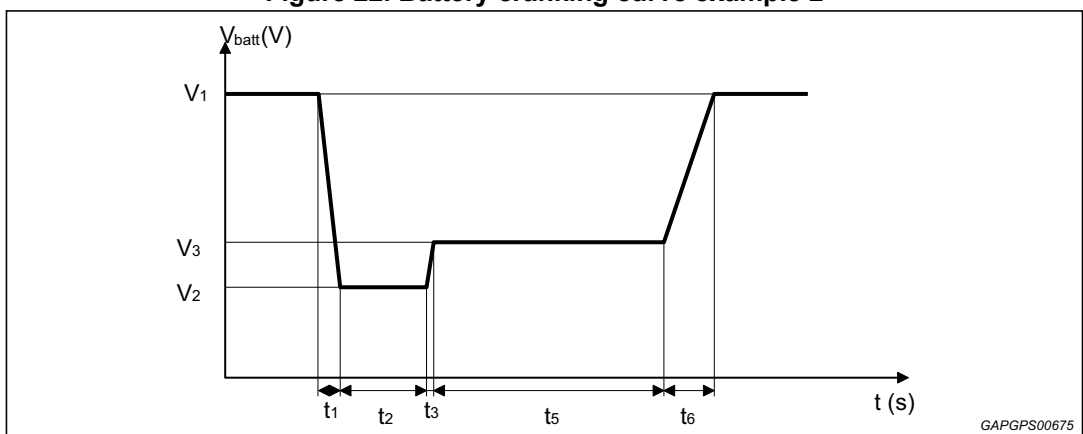

V1 = 16 V; V2 = 6 V; V3 = 7 V

t1 = 2 ms; t2 = 5 ms; t3 = 15 ms; t5 = 1 s; t6 = 50 ms

4.2.3 Advanced battery management (hybrid vehicles)

In hybrid vehicles, the engine ignition causes a fast increase of battery voltage which can reach 16 V in less than 10 ms. In addition to compatibility with low V_{batt} , STPA008 is able to sustain upwards fast battery transitions without causing unwanted audible effects, like pop noise, and without any sound interruption thanks to the innovative circuit topology.

Figure 23. Upwards fast battery transitions diagram

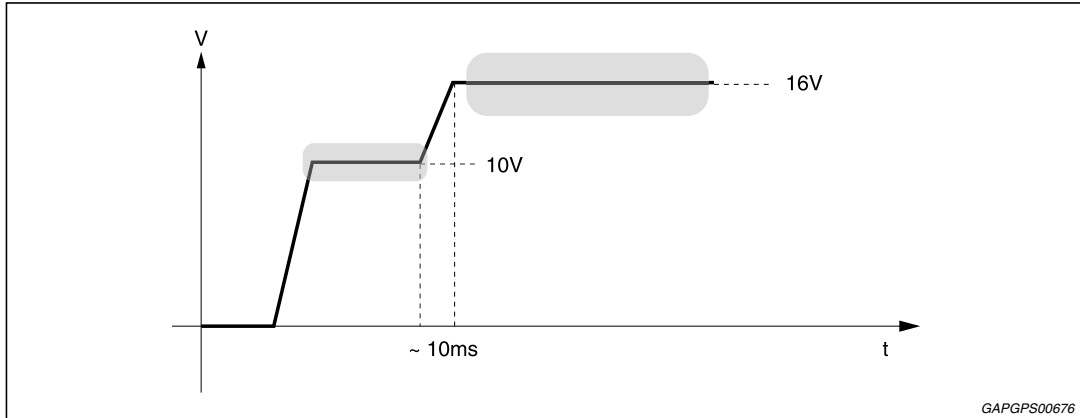

4.3 Protections

4.3.1 Short circuits and open load operation

When the IC detects a short circuit to ground, to V_{batt} or across the load, the output of the amplifier is put in three-state (high impedance condition).

In case of short circuit to ground or V_{cc} , the amplifier exits from the three-state condition only when the short-circuit is released and the output returns inside the limits imposed by an internal voltage comparator.

When a short across the load is present, the power stage sees an over-current and is brought in protection mode for about 100 μs . After this time, if the short circuit condition is removed the amplifier returns to play, otherwise the high impedance state is maintained and the check is repeated every 100 μs .

Disconnection of load (open load condition) doesn't affect the amplifier, which continues to play.

4.3.2 Over-voltage and load dump protection

When the battery voltage is higher than 19 V, the amplifier put in tri-state. It stops playing till the supply voltage returns in the permitted range.

The amplifier is protected against load dump surges having amplitude as high as 50 V and a rising time as low as 2 ms (see [Figure 24](#)).

Figure 24. Load dump protection diagram

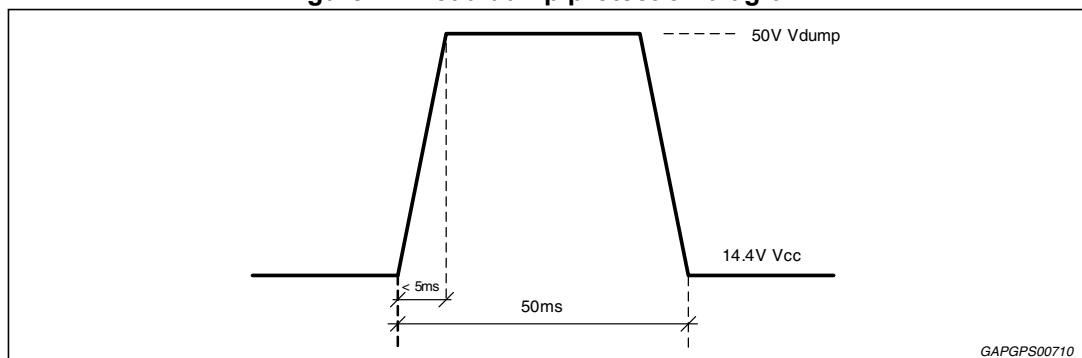

4.3.3 Thermal protection

If the junction temperature of the IC overcomes $T_j = 150\text{ }^\circ\text{C}$, a smooth mute is applied to reduce output power and limit power dissipation. If this is not enough and the junction temperature continues to increase, the amplifier is switched off when it reaches the maximum temperature of $170\text{ }^\circ\text{C}$.

Figure 25. Thermal protection diagram

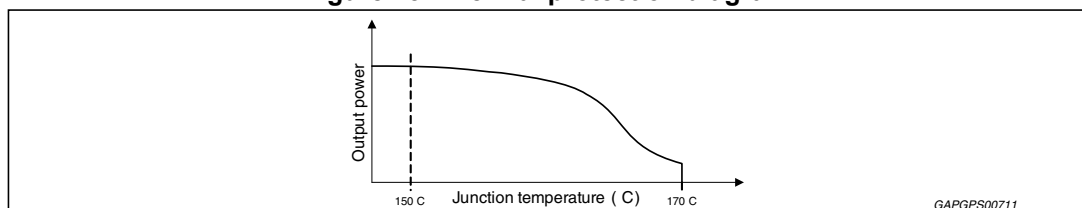

4.4 Warnings

4.4.1 DC offset detection (OD pin)

STPA008 integrates a DC offset detector to avoid that an anomalous input DC offset is multiplied by the amplifier gain producing a dangerous large offset at the output. In fact an output offset may lead to speakers damage for overheating. The detector works with the amplifier un-muted and no signal at the inputs.

When the differential output voltage is out of a window comparator with thresholds $\pm 2V$ (typ), the OD pin is pulled down.

4.4.2 Clipping detection and diagnostics (CD-DIAG pin)

When clipping occurs, the output signal is distorted. If the signal distortion on one of the output channels exceeds 1%, the CD-DIAG pin is pulled down. This information can be sent to an audio processor in order to reduce the input signal of the amplifier and reduce the clipping.

A short to ground and short to V_{cc} is pointed out by CD-DIAG. This pin is pulled down to 0 V till these shorts are present to inform the user a protection occurred.

CD-DIAG acts also as thermal warning. In fact every time T_j exceeds $140^\circ C$, it is pulled down to notify this occurrence.

Figure 26. Audio section waveforms

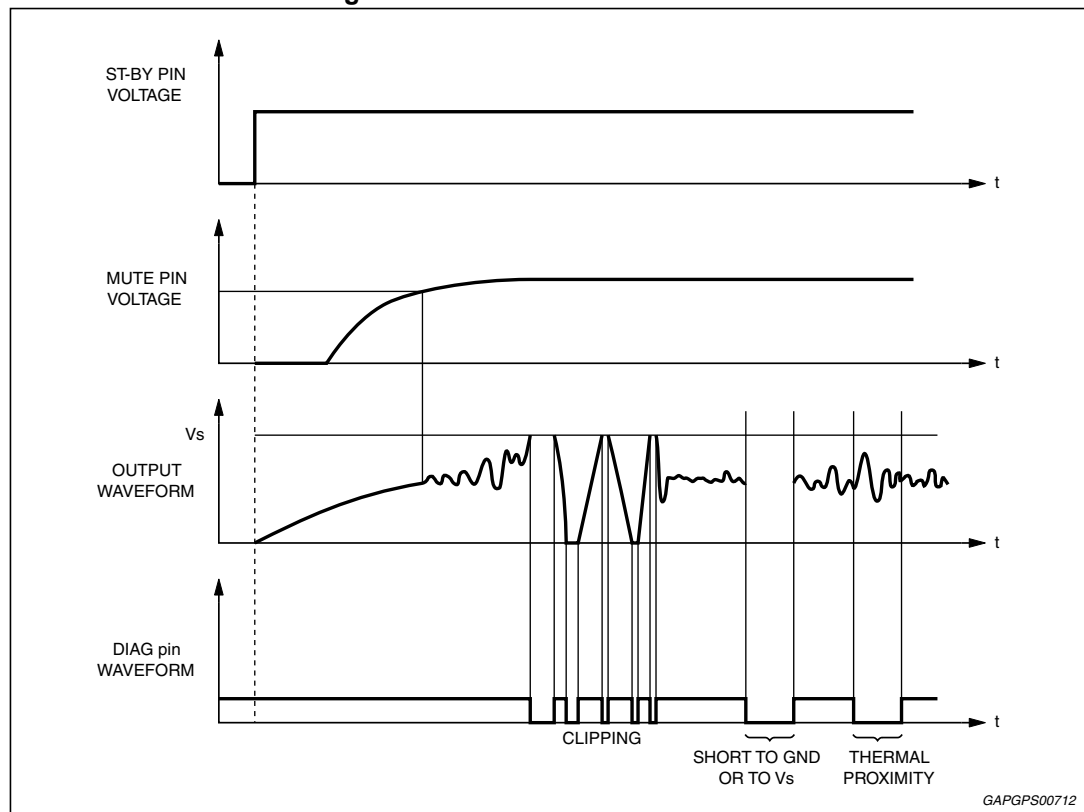

4.5 Heat sink definition

Assuming a power dissipation of 26 W (e.g. in the worst case situation of frequent clipping occurrence), considering T_j max is 150°C and assuming ambient temperature is 70 °C, the available temperature gap for a correct dissipation is 80 °C.

This means the thermal resistance of the system R_{Th} has to be $80 \text{ °C}/26 \text{ W} = 3 \text{ °C/W}$.

The junction to case thermal resistance is 1 °C/W. So the heat sink thermal resistance should be approximately 2 °C/W. This would avoid any thermal shutdown occurrence even after long-term and full-volume operation.

5 Package information

In order to meet environmental requirements, ST offers these devices in different grades of ECOPACK® packages, depending on their level of environmental compliance. ECOPACK® specifications, grade definitions and product status are available at: www.st.com.

ECOPACK® is an ST trademark.

5.1 Flexiwatt 27 (vertical) package information

Figure 27. Flexiwatt 27 (vertical) package outline

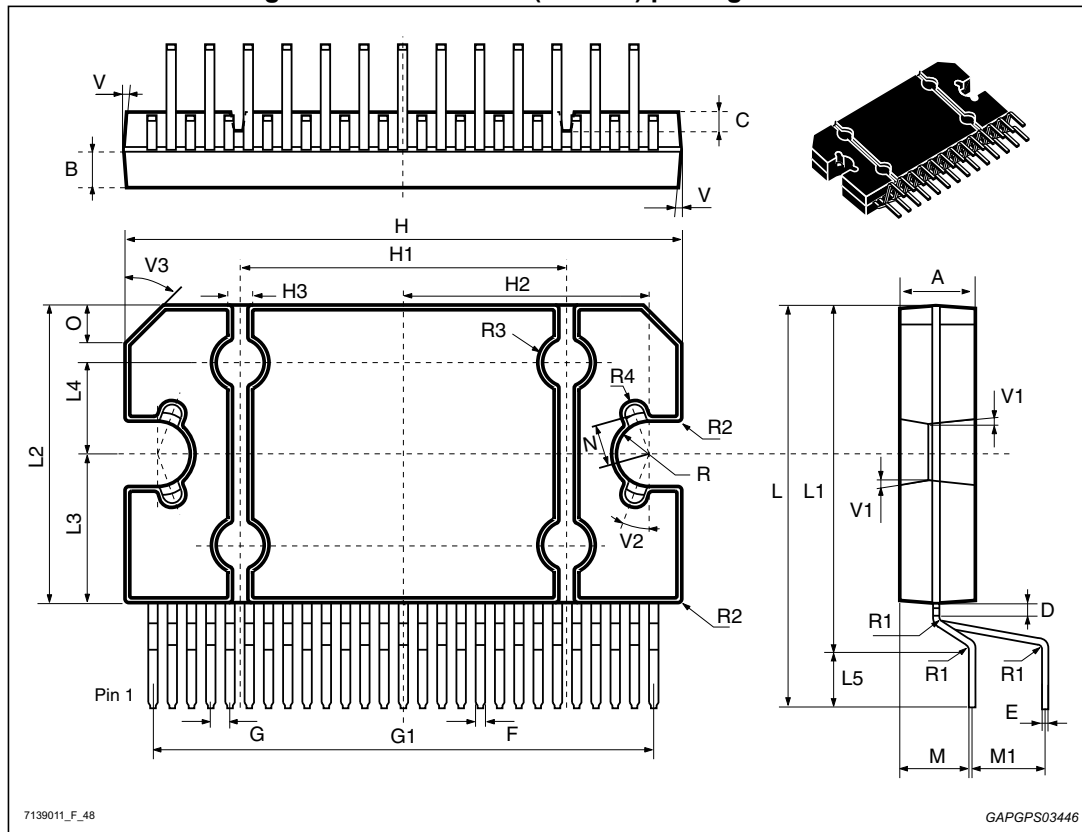

Table 6. Flexiwatt 27 (vertical) package mechanical data

Ref	Dimensions					
	Millimeters			Inches ⁽¹⁾		
	Min.	Typ.	Max.	Min.	Typ.	Max.
A	4.45	4.50	4.65	0.1752	0.1772	0.1831
B	1.80	1.90	2.00	0.0709	0.0748	0.0787
C	-	1.40	-	-	0.0551	-
D	0.75	0.90	1.05	0.0295	0.0354	0.0413

Table 6. Flexiwatt 27 (vertical) package mechanical data (continued)

Ref	Dimensions					
	Millimeters			Inches ⁽¹⁾		
	Min.	Typ.	Max.	Min.	Typ.	Max.
E	0.37	0.39	0.42	0.0146	0.0154	0.0165
F ⁽²⁾	-	-	0.57	-	-	0.0224
G	0.80	1.00	1.20	0.0315	0.0394	0.0472
G1	25.75	26.00	26.25	1.0138	1.0236	1.0335
H ⁽³⁾	28.90	29.23	29.30	1.1378	1.1508	1.1535
H1	-	17.00	-	-	0.6693	-
H2	-	12.80	-	-	0.5039	-
H3	-	0.80	-	-	0.0315	-
L ⁽³⁾	22.07	22.47	22.87	0.8689	0.8846	0.9004
L1	18.57	18.97	19.37	0.7311	0.7469	0.7626
L2 ⁽³⁾	15.50	15.70	15.90	0.6102	0.6181	0.6260
L3	7.70	7.85	7.95	0.3031	0.3091	0.3130
L4	-	5	-	-	0.1969	-
L5	3.35	3.5	3.65	0.1319	0.1378	0.1437
M	3.70	4.00	4.30	0.1457	0.1575	0.1693
M1	3.60	4.00	4.40	0.1417	0.1575	0.1732
N	-	2.20	-	-	0.0866	-
O	-	2	-	-	0.0787	-
R	-	1.70	-	-	0.0669	-
R1	-	0.5	-	-	0.0197	-
R2	-	0.3	-	-	0.0118	-
R3	-	1.25	-	-	0.0492	-
R4	-	0.50	-	-	0.0197	-
V	5°			5°		
V1	3°			3°		
V2	20°			20°		
V3	45°			45°		

1. Values in inches are converted from mm and rounded to 4 decimal digits.
2. dam-bar protusion not included.
3. molding protusion included.

5.2 Flexiwatt 25 (vertical) package information

Figure 28. Flexiwatt 25 (vertical) package outline

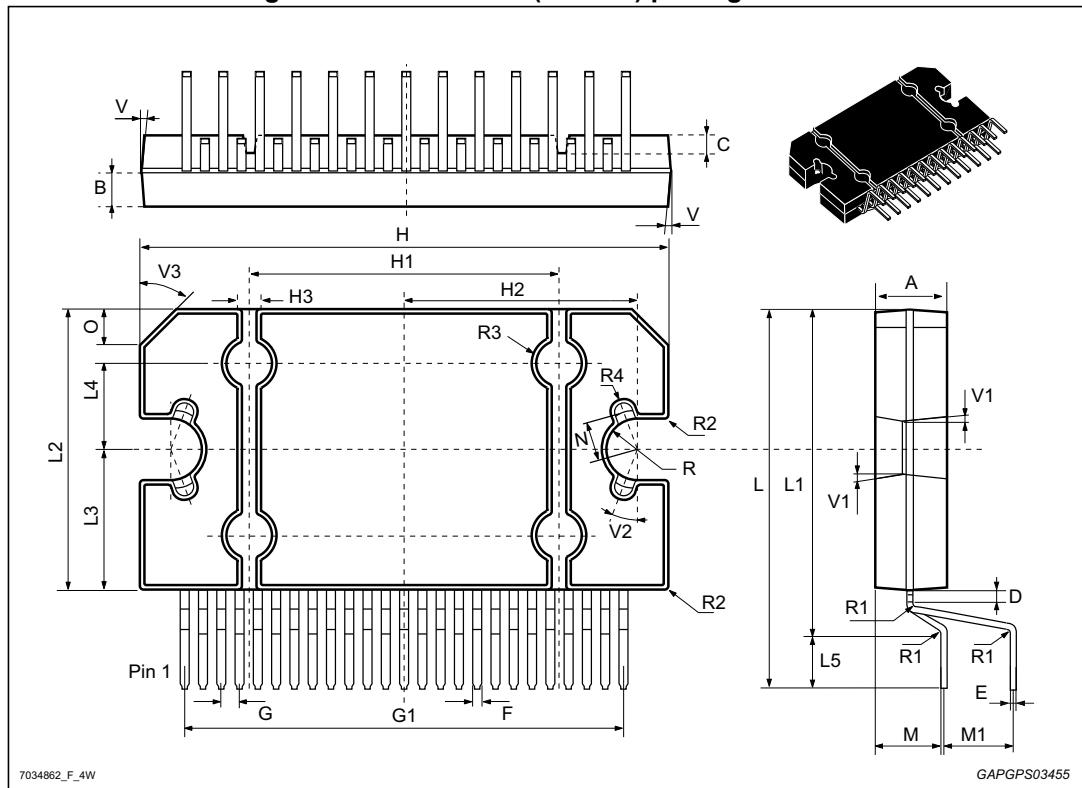

Table 7. Flexiwatt 25 (vertical) package mechanical data

Ref	Dimensions					
	Millimeters			Inches ⁽¹⁾		
	Min.	Typ.	Max.	Min.	Typ.	Max.
A	4.45	4.50	4.65	0.1752	0.1772	0.1831
B	1.80	1.90	2.00	0.0709	0.0748	0.0787
C	-	1.40	-	-	0.0551	-
D	0.75	0.90	1.05	0.0295	0.0354	0.0413
E	0.37	0.39	0.42	0.0146	0.0154	0.0165
F ⁽²⁾	-	-	0.570	-	-	0.0224
G	0.80	1.00	1.20	0.0315	0.0394	0.0472
G1	23.75	24.00	24.25	0.9350	0.9449	0.9547
H ⁽³⁾	28.90	29.23	29.30	1.1378	1.1508	1.1535
H1	-	17.00	-	-	0.6693	-
H2	-	12.80	-	-	0.5039	-
H3	-	0.80	-	-	0.0315	-

Table 7. Flexiwatt 25 (vertical) package mechanical data (continued)

Ref	Dimensions					
	Millimeters			Inches ⁽¹⁾		
	Min.	Typ.	Max.	Min.	Typ.	Max.
L ⁽³⁾	22.07	22.47	22.87	0.8689	0.8846	0.9004
L1	18.57	18.97	19.37	0.7311	0.7469	0.7626
L2 ⁽³⁾	15.50	15.70	15.90	0.6102	0.6181	0.6260
L3	7.70	7.85	7.95	0.3031	0.3091	0.3130
L4	-	5.00	-	-	0.1969	-
L5	3.35	3.50	3.65	0.1319	0.1378	0.1437
M	3.70	4.00	4.30	0.1457	0.1575	0.1693
M1	3.60	4.00	4.40	0.1417	0.1575	0.1732
N	-	2.20	-	-	0.0866	-
O	-	2.00	-	-	0.0787	-
R	-	1.70	-	-	0.0669	-
R1	-	0.50	-	-	0.0197	-
R2	-	0.30	-	-	0.0118	-
R3	-	1.25	-	-	0.0492	-
R4	-	0.50	-	-	0.0197	-
V	5°			5°		
V1	3°			3°		
V2	20°			20°		
V3	45°			45°		

1. Values in inches are converted from mm and rounded to 4 decimal digits.
2. dam-bar protusion not included.
3. molding protusion included.