



Chipsmall Limited consists of a professional team with an average of over 10 year of expertise in the distribution of electronic components. Based in Hongkong, we have already established firm and mutual-benefit business relationships with customers from,Europe,America and south Asia,supplying obsolete and hard-to-find components to meet their specific needs.

With the principle of "Quality Parts,Customers Priority,Honest Operation,and Considerate Service",our business mainly focus on the distribution of electronic components. Line cards we deal with include Microchip,ALPS,ROHM,Xilinx,Pulse,ON,Everlight and Freescale. Main products comprise IC,Modules,Potentiometer,IC Socket,Relay,Connector.Our parts cover such applications as commercial,industrial, and automotives areas.

We are looking forward to setting up business relationship with you and hope to provide you with the best service and solution. Let us make a better world for our industry!



Contact us

Tel: +86-755-8981 8866 Fax: +86-755-8427 6832

Email & Skype: info@chipsmall.com Web: www.chipsmall.com

Address: A1208, Overseas Decoration Building, #122 Zhenhua RD., Futian, Shenzhen, China



N-channel 20 V, 0.025 Ω typ., 2.3 A STripFET™ H5 Power MOSFET in a SOT-23 package

Datasheet — production data

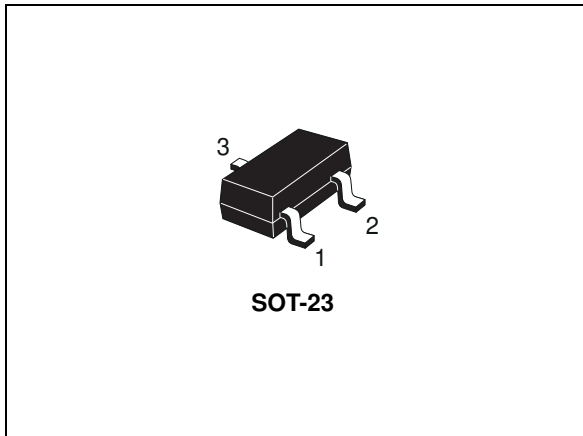
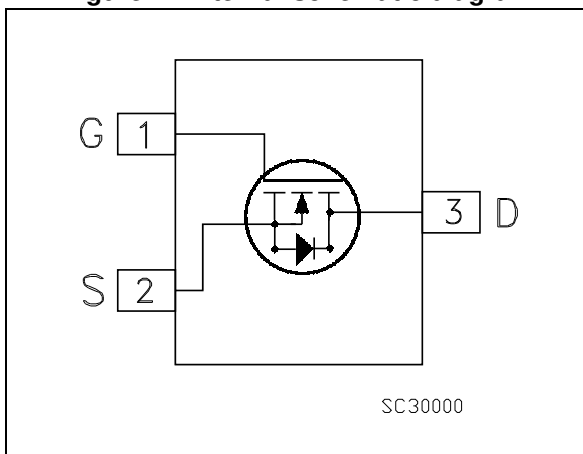

Figure 1. Internal schematic diagram



Features

Order code	V_{DS}	$R_{DS(on)}$ max	I_D	P_{TOT}
STR2N2VH5	20 V	0.03 Ω ($V_{GS}=4.5$ V)	2.3 A	0.35 W

- Low on-resistance $R_{DS(on)}$
- High avalanche ruggedness
- Low gate drive power loss

Applications

- Switching applications

Description

This device is an N-channel Power MOSFET developed using STMicroelectronics' STripFET™ H5 technology. The device has been optimized to achieve very low on-state resistance, contributing to a FoM that is among the best in its class.

Table 1. Device summary

Order code	Marking	Packages	Packaging
STR2N2VH5	STD1	SOT-23	Tape and reel

Contents

1	Electrical ratings	3
2	Electrical characteristics	4
	2.1 Electrical characteristics (curves)	6
3	Test circuits	8
4	Package mechanical data	9
5	Revision history	12

1 Electrical ratings

Table 2. Absolute maximum ratings

Symbol	Parameter	Value	Unit
V_{DS}	Drain-source voltage	20	V
V_{GS}	Gate-source voltage	± 8	V
$I_D^{(1)}$	Drain current (continuous) at $T_{pcb} = 25\text{ }^\circ\text{C}$	2.3	A
$I_D^{(1)}$	Drain current (continuous) at $T_{pcb} = 100\text{ }^\circ\text{C}$	1.4	A
$I_{DM}^{(1)(2)}$	Drain current (pulsed)	9.2	A
$P_{TOT}^{(1)}$	Total dissipation at $T_{pcb} = 25\text{ }^\circ\text{C}$	0.35	W
T_{stg}	Storage temperature	- 55 to 150	$^\circ\text{C}$
T_j	Max. operating junction temperature		$^\circ\text{C}$

1. This value is rated according to $R_{thj-pcb}$
2. Pulse width is limited by safe operating area

Table 3. Thermal data

Symbol	Parameter	Value	Unit
$R_{thj-pcb}^{(1)}$	Thermal resistance junction-pcb max	357	$^\circ\text{C}/\text{W}$

1. When mounted on 1 inch² FR-4, 2 Oz Cu, t < 10 sec.

2 Electrical characteristics

($T_C = 25\text{ °C}$ unless otherwise specified)

Table 4. On /off states

Symbol	Parameter	Test conditions	Min.	Typ.	Max.	Unit
$V_{(BR)DSS}$	Drain-source breakdown voltage	$V_{GS} = 0, I_D = 1\text{ mA}$	20			V
I_{DSS}	Zero gate voltage drain current	$V_{GS} = 0, V_{DS} = 20\text{ V}$			1	μA
		$V_{GS} = 0, V_{DS} = 20\text{ V}, T_C = 125\text{ °C}$			10	μA
I_{GSS}	Gate-body leakage current	$V_{DS} = 0, V_{GS} = \pm 8\text{ V}$			± 100	nA
$V_{GS(th)}$	Gate threshold voltage	$V_{DS} = V_{GS}, I_D = 250\text{ }\mu\text{A}$	0.7			V
$R_{DS(on)}$	Static drain-source on-resistance	$V_{GS} = 4.5\text{ V}, I_D = 2\text{ A}$		0.025	0.03	Ω
		$V_{GS} = 2.5\text{ V}, I_D = 2\text{ A}$		0.031	0.04	Ω

Table 5. Dynamic

Symbol	Parameter	Test conditions	Min.	Typ.	Max.	Unit
C_{iss}	Input capacitance	$V_{GS} = 0, V_{DS} = 16\text{ V}, f = 1\text{ MHz}$	-	367	-	pF
C_{oss}	Output capacitance		-	92	-	pF
C_{riss}	Reverse transfer capacitance		-	16	-	pF
Q_g	Total gate charge	$V_{DD} = 16\text{ V}, I_D = 2\text{ A}, V_{GS} = 4.5\text{ V}$ (see Figure 14)	-	4.6	-	nC
Q_{gs}	Gate-source charge		-	0.9	-	nC
Q_{gd}	Gate-drain charge		-	1	-	nC

Table 6. Switching times

Symbol	Parameter	Test conditions	Min.	Typ.	Max.	Unit
$t_{d(on)}$	Voltage delay time	$V_{DD} = 16\text{ V}, I_D = 2\text{ A}, R_G = 4.7\text{ }\Omega, V_{GS} = 4.5\text{ V}$ (see Figure 15 and Figure 18)	-	4.8	-	ns
$t_r (V)$	Voltage rise time		-	14.4	-	ns
$t_d (off)$	Current fall time		-	17	-	ns
t_f	Crossing time		-	4	-	ns

Table 7. Source drain diode

Symbol	Parameter	Test conditions	Min.	Typ.	Max.	Unit
I_{SD}	Source-drain current		-		2.3	A
$I_{SDM}^{(1)}$	Source-drain current (pulsed)		-		9.2	A
$V_{SD}^{(2)}$	Forward on voltage	$V_{GS} = 0, I_{SD} = 2 \text{ A}$	-		1.1	V
t_{rr}	Reverse recovery time	$I_{SD} = 2 \text{ A}, di/dt = 100 \text{ A}/\mu\text{s}$ $V_{DD} = 16 \text{ V}, T_j = 150 \text{ }^\circ\text{C}$ (see Figure 18)	-	10		ns
Q_{rr}	Reverse recovery charge		-	24		nC
I_{RRM}	Reverse recovery current		-	4.8		A

1. Pulse width limited by safe operating area.
2. Pulsed: pulse duration = 300 μs , duty cycle 1.5%

2.1 Electrical characteristics (curves)

Figure 2. Safe operating area

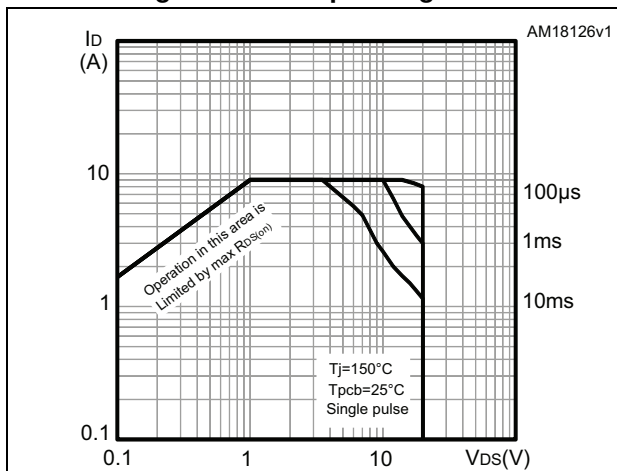

Figure 3. Thermal impedance

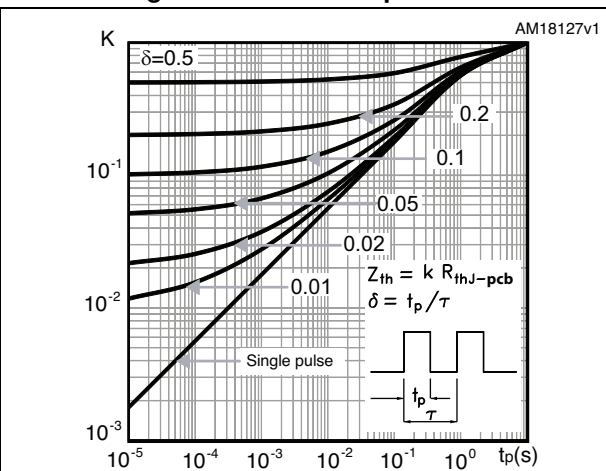

Figure 4. Output characteristics

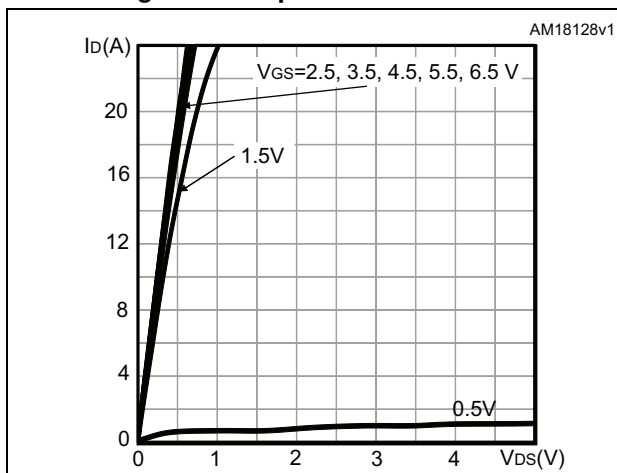

Figure 5. Transfer characteristics

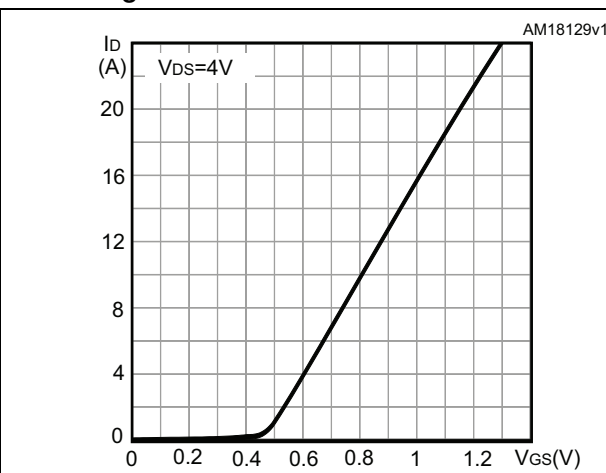

Figure 6. Gate charge vs gate-source voltage

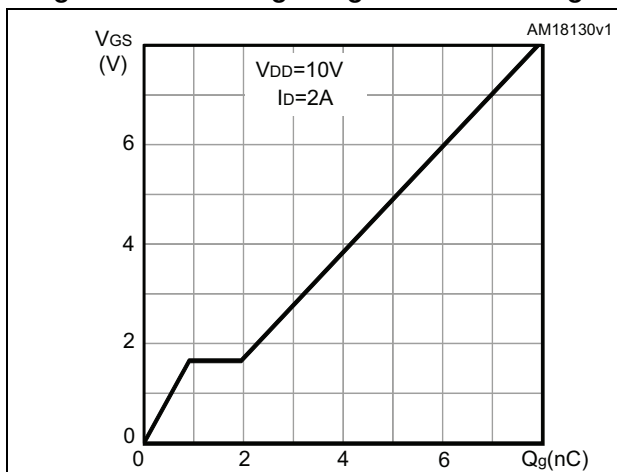

Figure 7. Static drain-source on-resistance

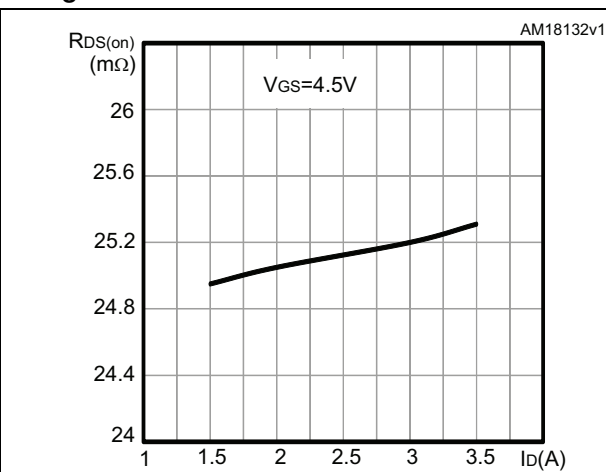

Figure 8. Capacitance variations

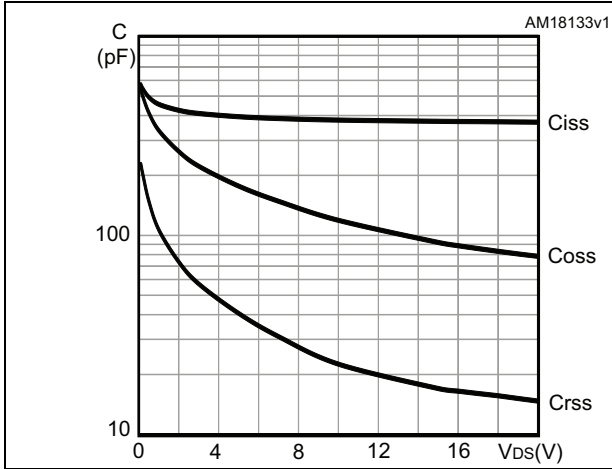

Figure 9. Normalized gate threshold voltage vs temperature

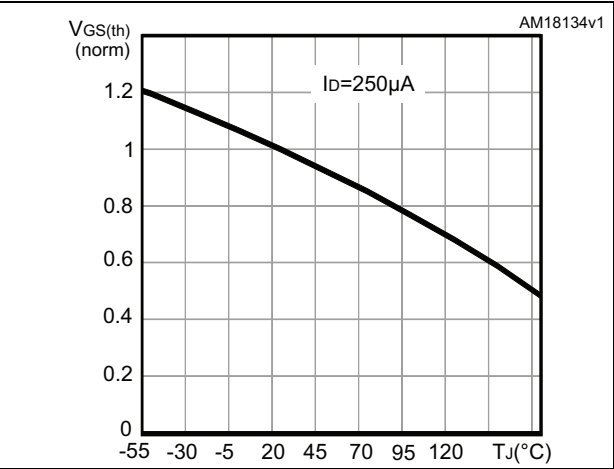

Figure 10. Normalized on-resistance vs temperature

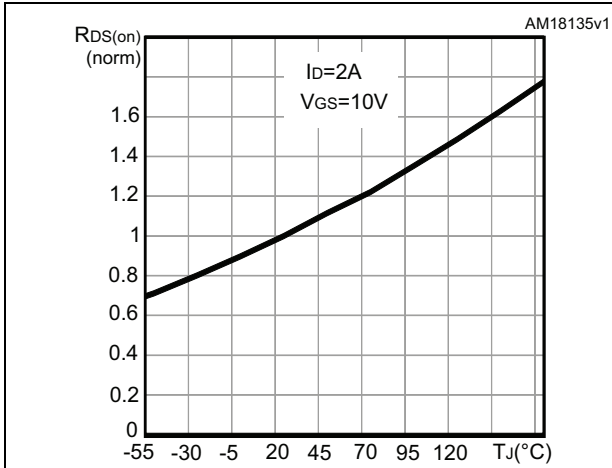

Figure 11. Normalized V_{(BR)DSS} vs temperature

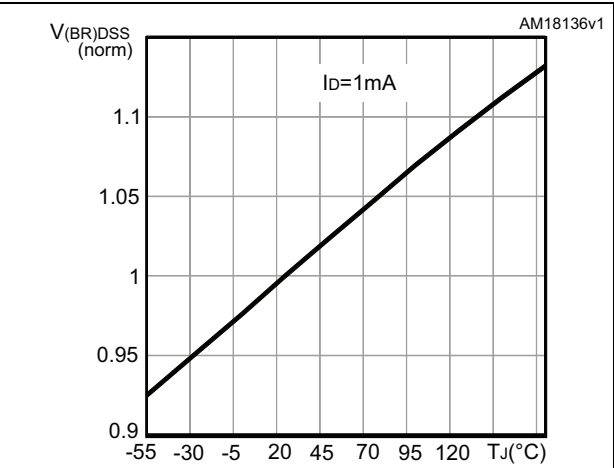
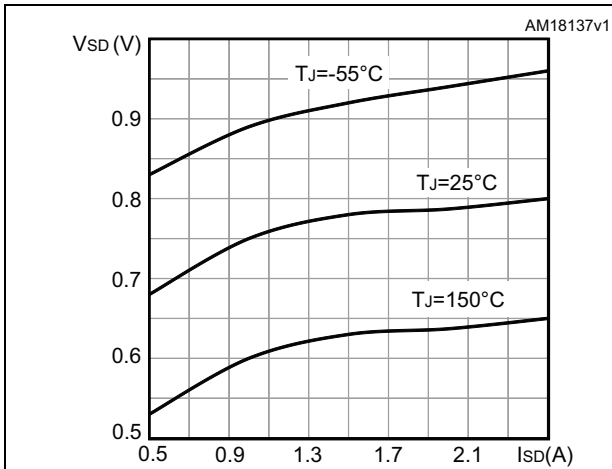

Figure 12. Source-drain diode forward characteristics



3 Test circuits

Figure 13. Switching times test circuit for resistive load

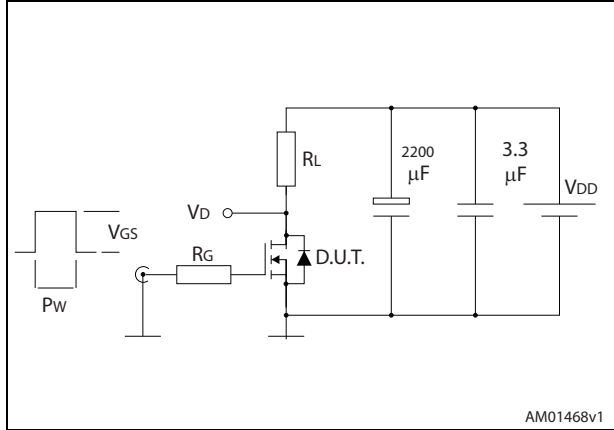

Figure 14. Gate charge test circuit

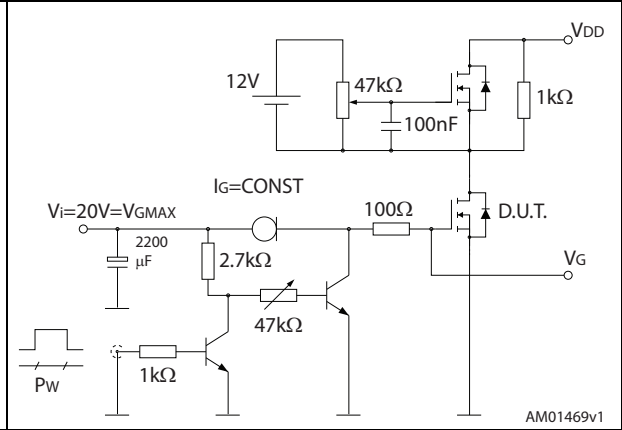

Figure 15. Test circuit for inductive load switching and diode recovery times

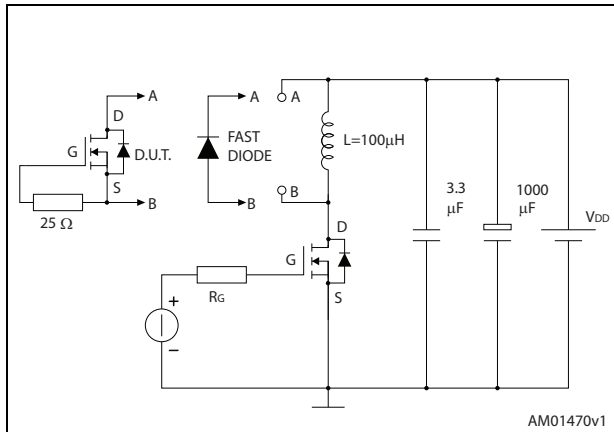

Figure 16. Unclamped inductive load test circuit

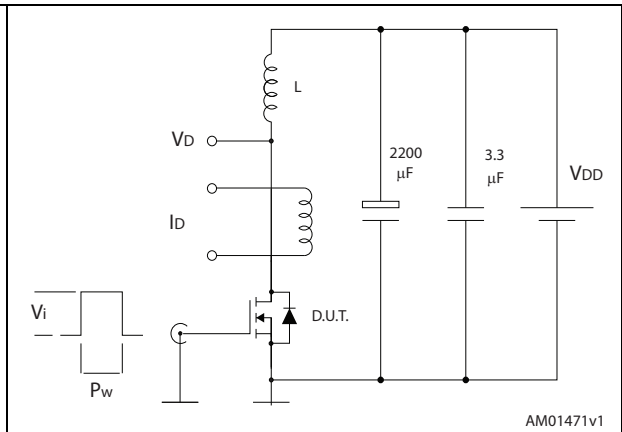

Figure 17. Unclamped inductive waveform

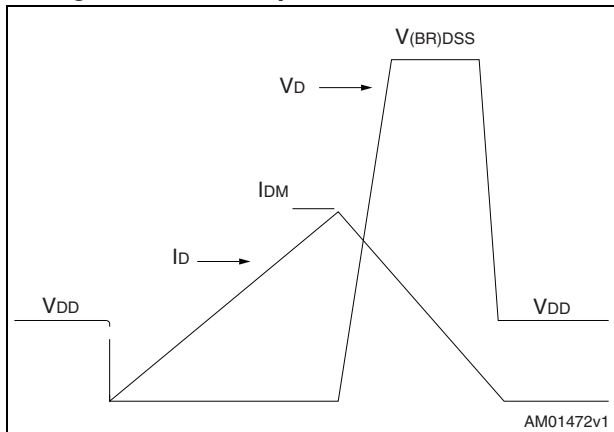
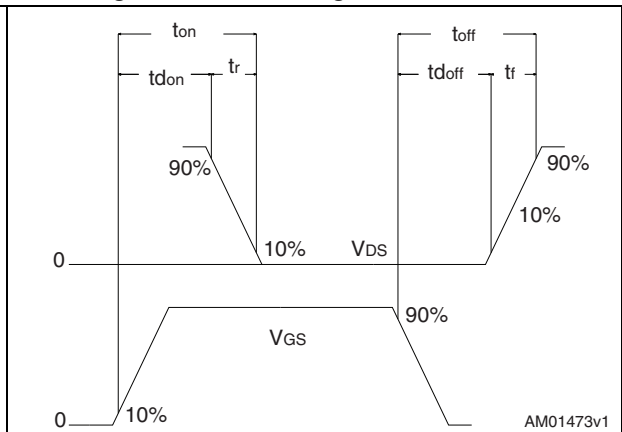

Figure 18. Switching time waveform



4 Package mechanical data

In order to meet environmental requirements, ST offers these devices in different grades of ECOPACK[®] packages, depending on their level of environmental compliance. ECOPACK[®] specifications, grade definitions and product status are available at: www.st.com. ECOPACK[®] is an ST trademark.

Figure 19. SOT-23 mechanical drawing

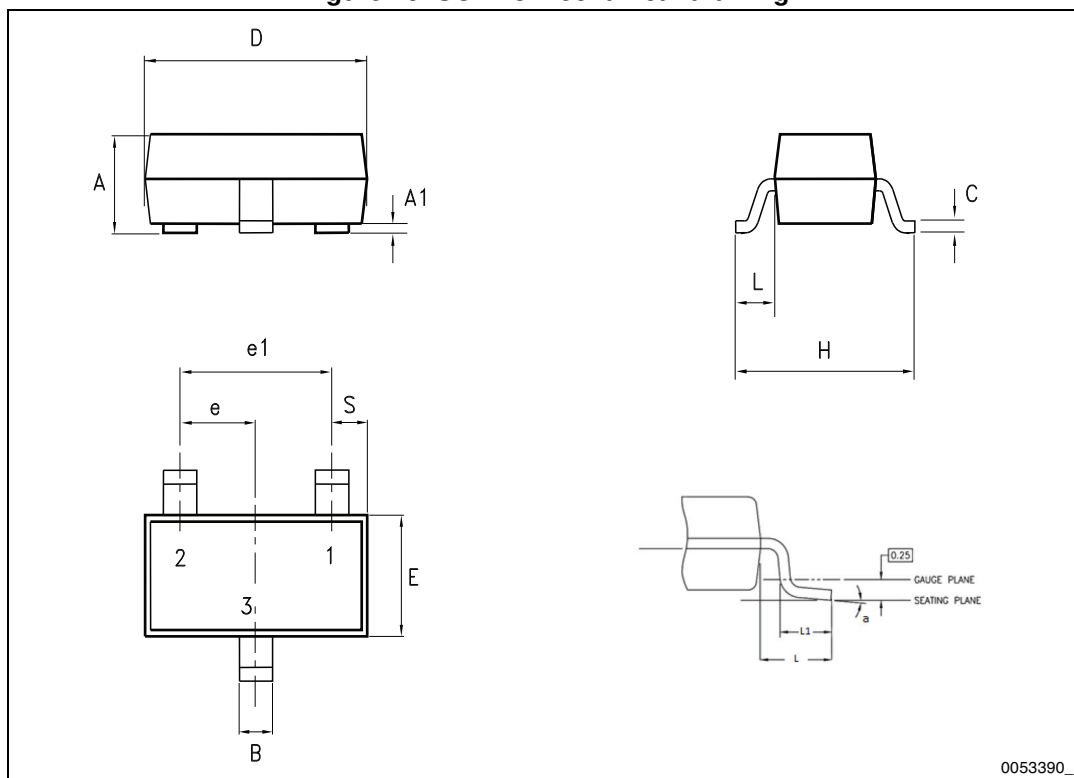

0053390_1

Table 8. SOT-23 mechanical data

Dim.	mm		
	Min.	Typ.	Max.
A	0.89		1.40
A1	0		0.10
B	0.30		0.51
C	0.085		0.18
D	2.75		3.04
e	0.85		1.05
e1	1.70		2.10
E	1.20		1.75
H	2.10		3.00
L		0.60	
S	0.35		0.65
L1	0.25		0.55
a	0°		8°

Figure 20. SOT-23 recommended footprint (a)

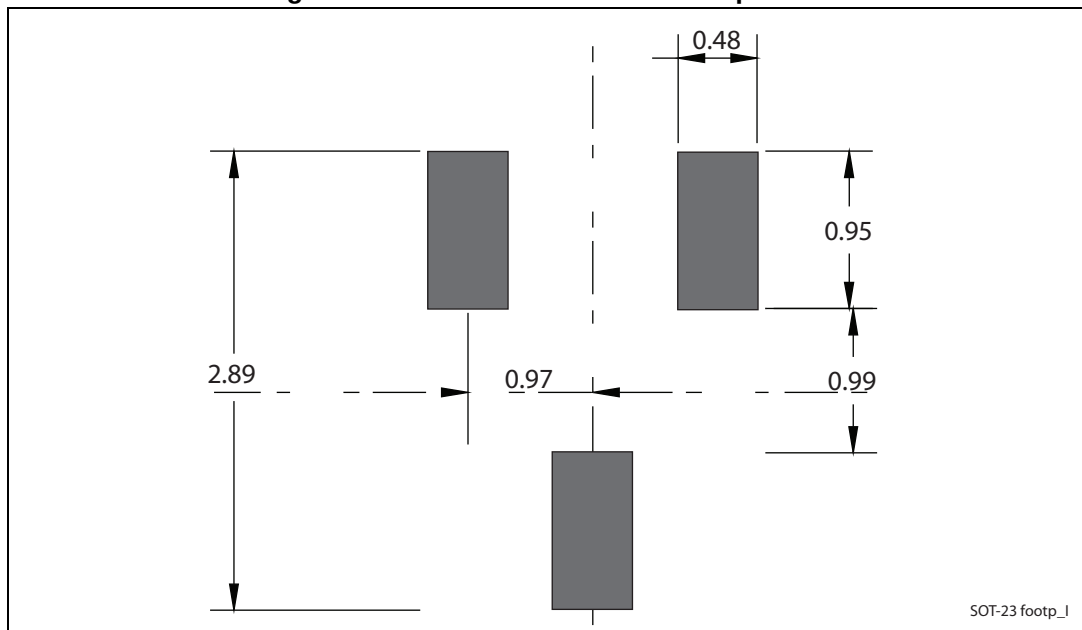

a. Dimensions are in mm.

5 Revision history

Table 9. Document revision history

Date	Revision	Changes
19-Oct-2012	1	First release.
14-Jan-2013	2	Modified: $R_{DS(on)}$ values
19-Mar-2014	3	<ul style="list-style-type: none">– The part number STT5N2VH5 has been moved to a separate datasheet– Modified: the entire typical values in Table 5, 6 and 7– Added: Section 2.1: Electrical characteristics (curves)– Minor text changes
25-Jul-2014	4	<ul style="list-style-type: none">– Modified: title, description and features– Updated: Figure 12– Minor text changes

IMPORTANT NOTICE – PLEASE READ CAREFULLY

STMicroelectronics NV and its subsidiaries ("ST") reserve the right to make changes, corrections, enhancements, modifications, and improvements to ST products and/or to this document at any time without notice. Purchasers should obtain the latest relevant information on ST products before placing orders. ST products are sold pursuant to ST's terms and conditions of sale in place at the time of order acknowledgement.

Purchasers are solely responsible for the choice, selection, and use of ST products and ST assumes no liability for application assistance or the design of Purchasers' products.

No license, express or implied, to any intellectual property right is granted by ST herein.

Resale of ST products with provisions different from the information set forth herein shall void any warranty granted by ST for such product.

ST and the ST logo are trademarks of ST. All other product or service names are the property of their respective owners.

Information in this document supersedes and replaces information previously supplied in any prior versions of this document.

© 2014 STMicroelectronics – All rights reserved