



Chipsmall Limited consists of a professional team with an average of over 10 year of expertise in the distribution of electronic components. Based in Hongkong, we have already established firm and mutual-benefit business relationships with customers from,Europe,America and south Asia,supplying obsolete and hard-to-find components to meet their specific needs.

With the principle of "Quality Parts,Customers Priority,Honest Operation,and Considerate Service",our business mainly focus on the distribution of electronic components. Line cards we deal with include Microchip,ALPS,ROHM,Xilinx,Pulse,ON,Everlight and Freescale. Main products comprise IC,Modules,Potentiometer,IC Socket,Relay,Connector.Our parts cover such applications as commercial,industrial, and automotives areas.

We are looking forward to setting up business relationship with you and hope to provide you with the best service and solution. Let us make a better world for our industry!



## Contact us

Tel: +86-755-8981 8866 Fax: +86-755-8427 6832

Email & Skype: info@chipsmall.com Web: www.chipsmall.com

Address: A1208, Overseas Decoration Building, #122 Zhenhua RD., Futian, Shenzhen, China





# STS12NH3LL

N-channel 30 V - 0.008  $\Omega$  - 12 A - SO-8  
ultra low gate charge STripFET™ Power MOSFET

## Features

Type	V <sub>DSS</sub>	R <sub>DS(on)</sub>	I <sub>D</sub>
STS12NH3LL	30 V	<0.0105 $\Omega$	12 A

- Optimal R<sub>DS(on)</sub> x Q<sub>g</sub> trade-off @ 4.5 V
- Switching losses reduced
- Low input capacitance
- Low threshold device

## Application

- Switching applications

## Description

This series is based on the latest generation of ST's proprietary "STripFET™" technology. An innovative layout enables the device to also exhibit extremely low gate charge for the most demanding requirements as high-side switch in high-frequency DC-DC converters. It's therefore ideal for high-density converters in telecom and computer applications.

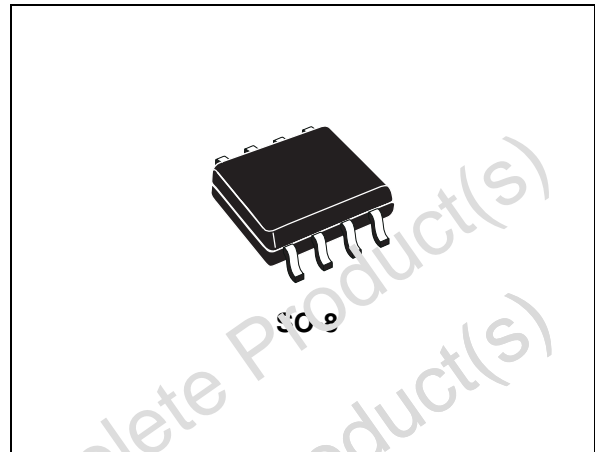

Figure 1. Internal schematic diagram

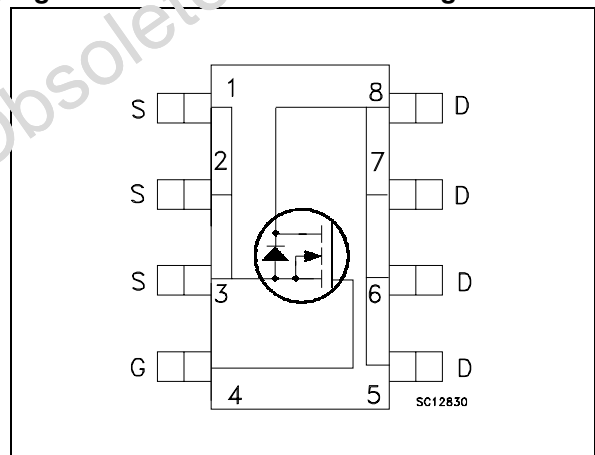

Table 1. Device summary

Order code	Marking	Packag	Packaging
STS12NH3LL	12H3LL	SO-8	Tape & reel

# Contents

<b>1</b>	<b>Electrical ratings</b> .....	<b>3</b>
<b>2</b>	<b>Electrical characteristics</b> .....	<b>4</b>
2.1	Electrical characteristics (curves) .....	6
<b>3</b>	<b>Test circuit</b> .....	<b>8</b>
<b>4</b>	<b>Package mechanical data</b> .....	<b>10</b>
<b>5</b>	<b>Revision history</b> .....	<b>12</b>

Obsolete Product(s) - Obsolete Product(s)  
Obsolete Product(s) - Obsolete Product(s)

# 1 Electrical ratings

**Table 2. Absolute maximum ratings**

Symbol	Parameter	Value	Unit
$V_{DS}$	Drain-source voltage ( $V_{GS} = 0$ )	30	V
$V_{GS}^{(1)}$	Gate-source voltage	$\pm 16$	V
$V_{GS}^{(2)}$	Gate-source voltage	$\pm 18$	V
$I_D$	Drain current (continuous) at $T_C = 25\text{ }^\circ\text{C}$	12	A
$I_D$	Drain current (continuous) at $T_C = 100\text{ }^\circ\text{C}$	7.5	A
$I_{DM}^{(3)}$	Drain current (pulsed)	48	A
$P_{TOT}$	Total dissipation at $T_C = 25\text{ }^\circ\text{C}$	2.7	W
$T_J$ $T_{stg}$	Operating junction temperature Storage temperature	-55 to 150	$^\circ\text{C}$

1. Continuous mode
2. Guaranteed for test time  $\leq 15\text{ ms}$
3. Pulse width limited by safe operating area

**Table 3. Thermal resistance**

Symbol	Parameter	Value	Unit
$R_{thj-amb}^{(1)}$	Thermal resistance junction-ambient	47	$^\circ\text{C/W}$

1. When mounted on FR-4 board of 1inch<sup>2</sup>, 2oz Cu,  $t < 10\text{ sec}$

## 2 Electrical characteristics

( $T_{CASE}=25^{\circ}C$  unless otherwise specified)

**Table 4. On/off states**

Symbol	Parameter	Test conditions	Min.	Typ.	Max.	Unit
$V_{(BR)DSS}$	Drain-source breakdown voltage	$I_D = 250 \mu A, V_{GS} = 0$	30			V
$I_{DSS}$	Zero gate voltage drain current ( $V_{GS} = 0$ )	$V_{DS} = \text{Max rating},$ $V_{DS} = \text{Max rating} @ 125^{\circ}C$			1 10	$\mu A$ $\mu A$
$I_{GSS}$	Gate body leakage current ( $V_{DS} = 0$ )	$V_{GS} = \pm 16 V$			100	nA
$V_{GS(th)}$	Gate threshold voltage	$V_{DS} = V_{GS}, I_D = 250 \mu A$	1			V
$R_{DS(on)}$	Static drain-source on resistance	$V_{GS} = 10 V, I_D = 6 A$ $V_{GS} = 4.5 V, I_D = 6 A$		0.008 0.010	0.0105 0.013	$\Omega$ $\Omega$

**Table 5. Dynamic**

Symbol	Parameter	Test conditions	Min.	Typ.	Max.	Unit
$g_{fs}$	Forward transconductance	$V_{DS} = 10 V, I_D = 12 A$		38		S
$C_{iss}$	Input capacitance	$V_{DS} = 25 V, f = 1 \text{ MHz},$ $V_{GS} = 0$		965		pF
$C_{oss}$	Output capacitance			285		pF
$C_{rss}$	Reverse transfer capacitance			38		pF
$Q_g$	Total gate charge	$V_{DD} = 15 V, I_D = 12 A$		9	12	nC
$Q_{gs}$	Gate-source charge	$V_{GS} = 4.5 V$		3.7		nC
$Q_{gd}$	Gate-drain charge	(see Figure 20)		3		nC
$Q_{gs1}$	Pre $V_{th}$ gate-to-source charge	$V_{DD} = 15 V, I_D = 12 A$		2.5		nC
$Q_{gs2}$	Post $V_{th}$ gate-to-source charge	$V_{GS} = 4.5 V$ (see Figure 20)		1.2		nC
$R_G$	Gate Input Resistance	$f = 1 \text{ MHz}$ Gate DC Bias = 0 Test signal level = 20 mV open drain	0.5	1.5	2.5	$\Omega$

**Table 6. Switching times**

Symbol	Parameter	Test conditions	Min.	Typ.	Max.	Unit
$t_{d(on)}$	Turn-on delay time	$V_{DD}=15\text{ V}$ , $I_D=6\text{ A}$ , $R_G=4.7\ \Omega$ , $V_{GS}=4.5\text{ V}$ <i>(see Figure 14)</i>		15		ns
$t_r$	Rise time			32		ns
$t_{d(off)}$	Turn-off delay time			18		ns
$t_f$	Fall time			8.5		ns

**Table 7. Source drain diode**

Symbol	Parameter	Test conditions	Min	Typ.	Max	Unit
$I_{SD}$	Source-drain current				2	A
$I_{SDM}^{(1)}$	Source-drain current (pulsed)				48	A
$V_{SD}^{(2)}$	Forward on Voltage	$I_{SD}=12\text{ A}$ , $V_{GS}=0$			1.3	V
$t_{rr}$	Reverse recovery time	$I_{SD}=12\text{ A}$ , $di/dt = 100\text{ A}/\mu\text{s}$ , $V_{DD}=20\text{ V}$ , $T_J=150\text{ }^\circ\text{C}$ <i>(see Figure 16)</i>		24		ns
$Q_{rr}$	Reverse recovery charge			17.4		nC
$I_{RRM}$	Reverse recovery current			1.45		A

1. Pulse width limited by safe operating area
2. Pulsed: pulse duration=300  $\mu\text{s}$ , duty cycle 1.5%

## 2.1 Electrical characteristics (curves)

Figure 2. Safe operating area

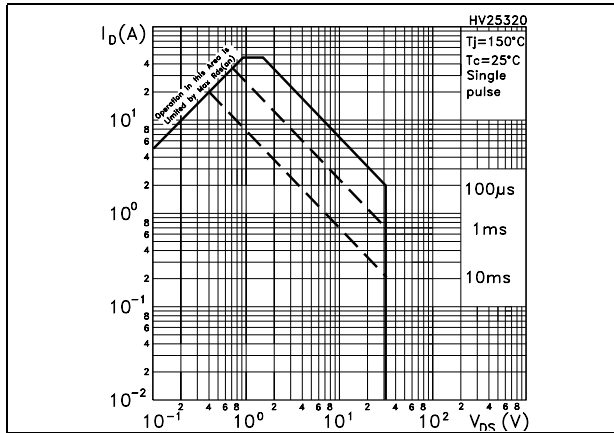

Figure 3. Thermal impedance

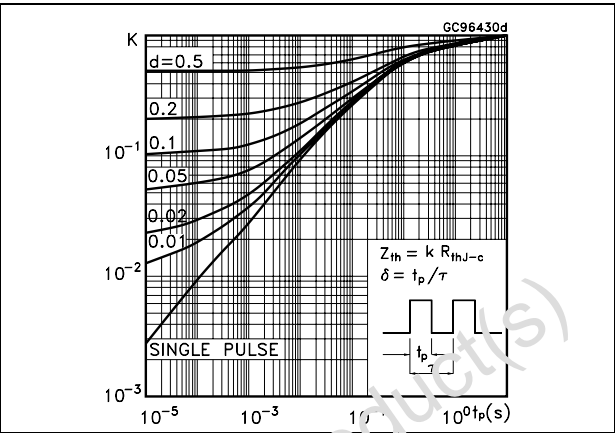

Figure 4. Output characteristics

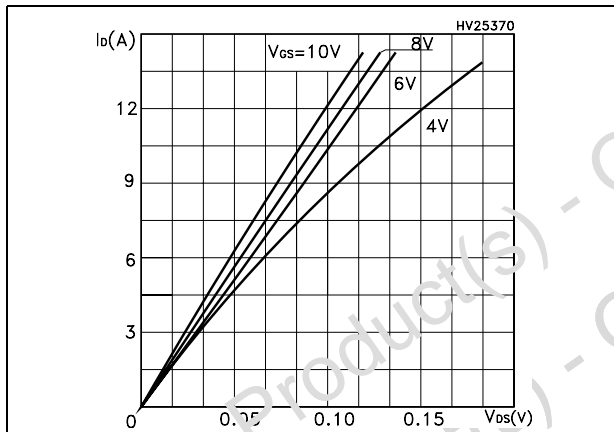

Figure 5. Transfer characteristics

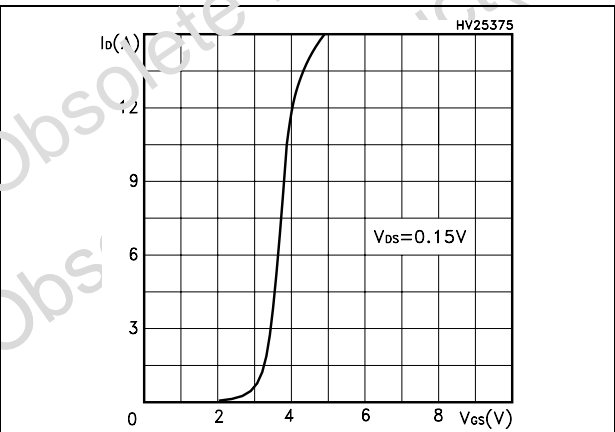

Figure 6. Transconductance

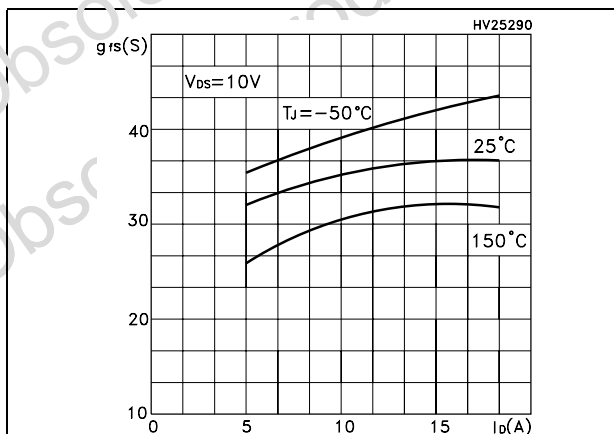

Figure 7. Static drain-source on resistance

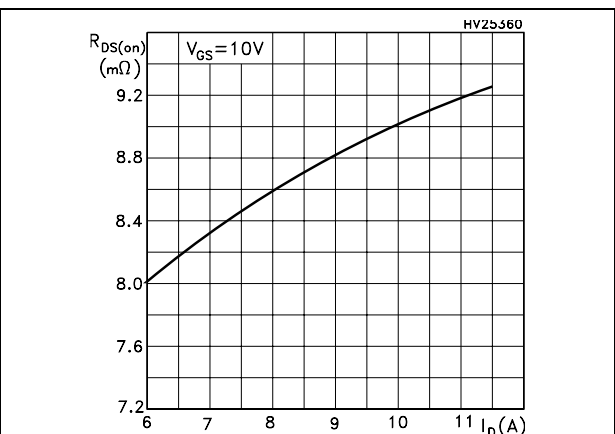

Figure 8. Gate charge vs gate-source voltage Figure 9. Capacitance variations

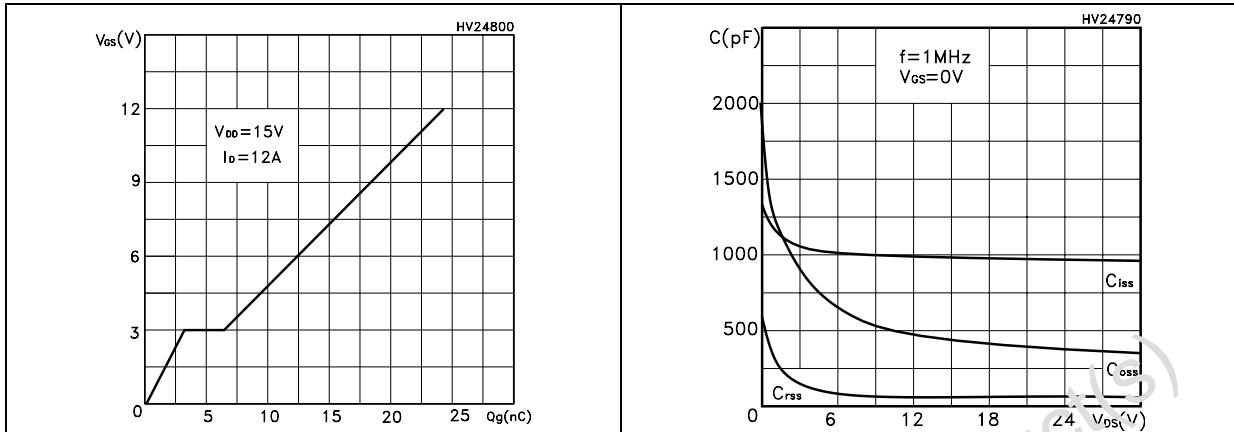

Figure 10. Normalized gate threshold voltage vs temperature Figure 11. Normalized on resistance vs temperature

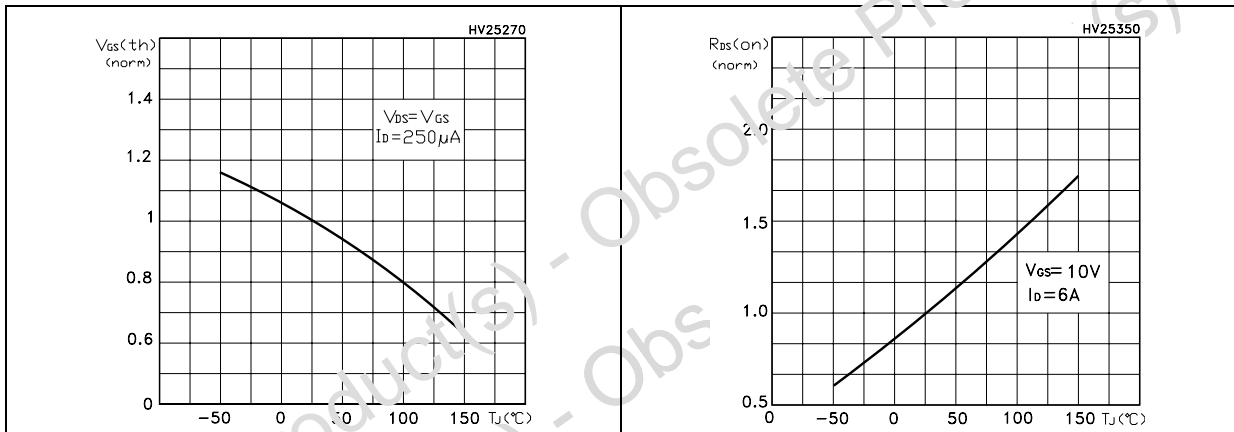
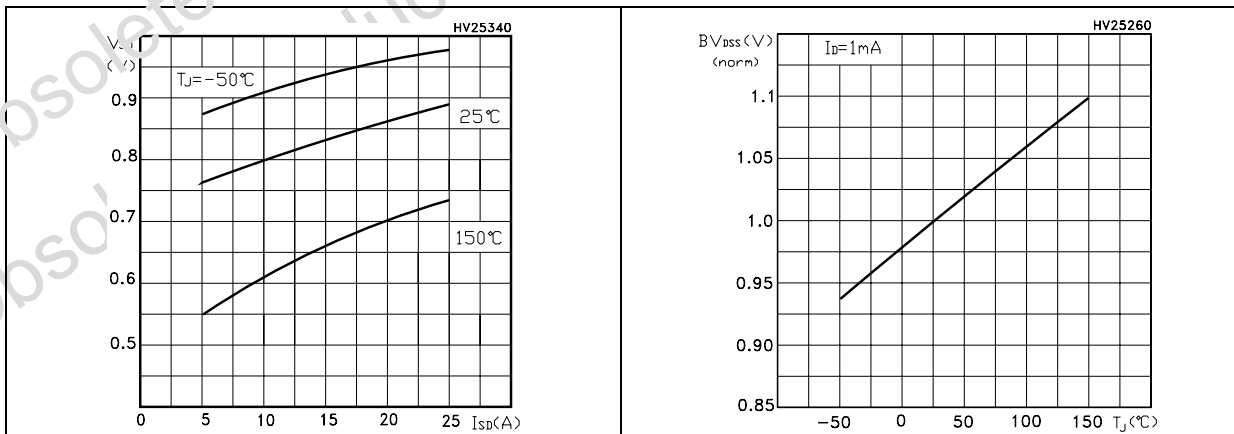

Figure 12. Source-drain diode forward characteristics Figure 13. Normalized  $B_{V_{DS}}$  vs temperature





### 3 Test circuit

Figure 14. Switching times test circuit for resistive load

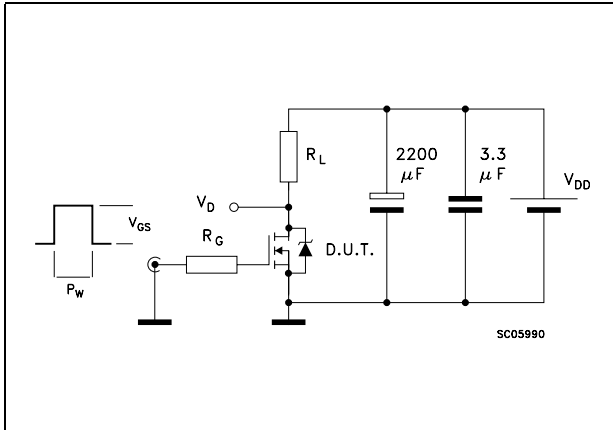

Figure 15. Gate charge test circuit

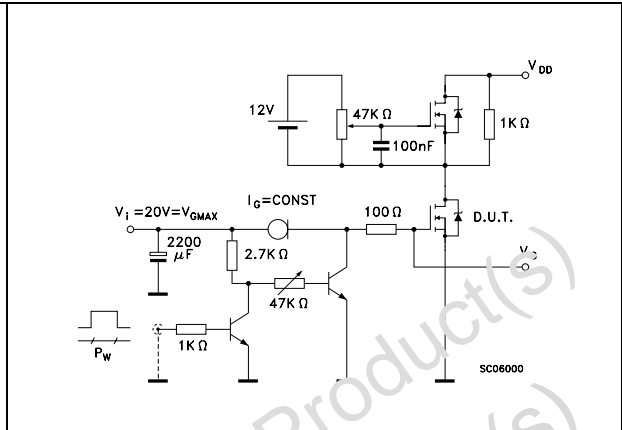

Figure 16. Test circuit for inductive load switching and diode recovery times

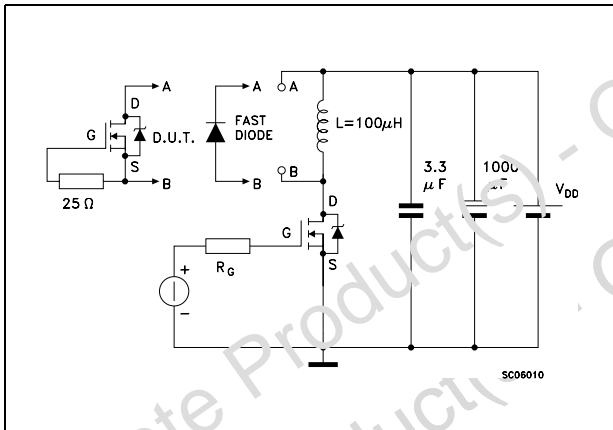

Figure 17. Unclamped inductive load test circuit

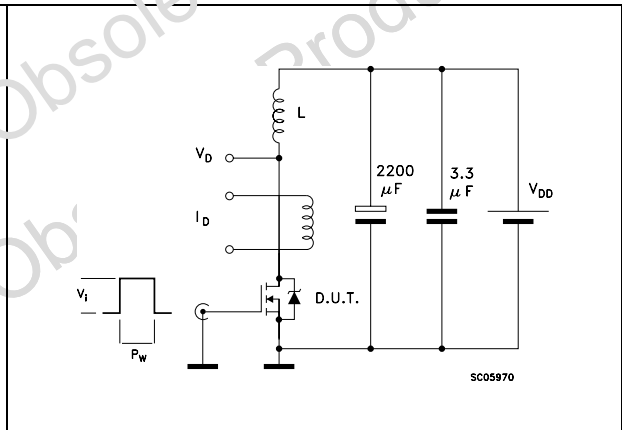

Figure 18. Unclamped inductive waveform

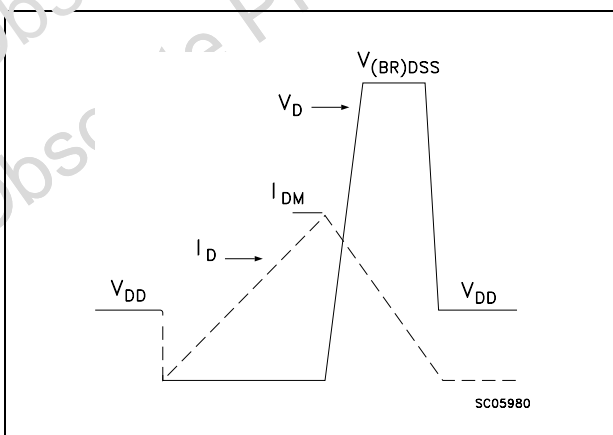

Figure 19. Switching time waveform

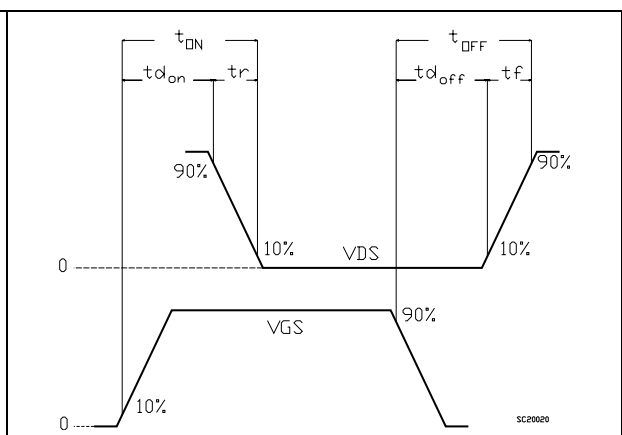
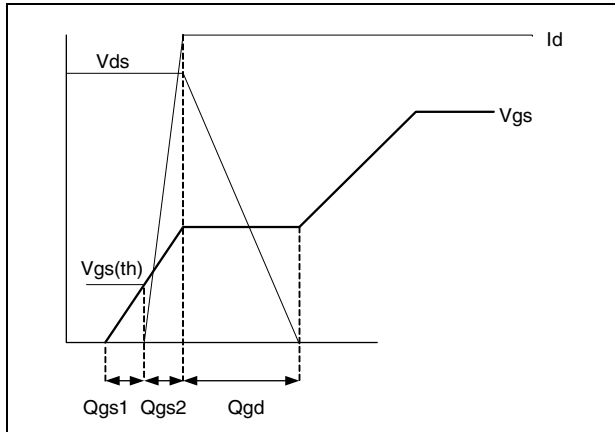

Figure 20. Gate charge waveform



Obsolete Product(s) - Obsolete Product(s)  
Obsolete Product(s) - Obsolete Product(s)

## 4 Package mechanical data

In order to meet environmental requirements, ST offers these devices in ECOPACK® packages. These packages have a Lead-free second level interconnect. The category of second level interconnect is marked on the package and on the inner box label, in compliance with JEDEC Standard JESD97. The maximum ratings related to soldering conditions are also marked on the inner box label. ECOPACK is an ST trademark. ECOPACK specifications are available at: [www.st.com](http://www.st.com)

Obsolete Product(s) - Obsolete Product(s)  
Obsolete Product(s) - Obsolete Product(s)

**SO-8 MECHANICAL DATA**

DIM.	mm.			inch		
	MIN.	TYP.	MAX.	MIN.	TYP.	MAX.
A			1.75			0.068
a1	0.1		0.25	0.003		0.009
a2			1.65			0.064
a3	0.65		0.85	0.025		0.033
b	0.35		0.48	0.013		0.018
b1	0.19		0.25	0.007		0.010
C	0.25		0.5	0.010		0.019
c1	45 (typ.)					
D	4.8		5.0	0.188		0.196
E	5.8		6.2	0.228		0.244
e		1.27			0.050	
e3		3.81			0.150	
F	3.8		4.0	0.14		0.157
L	0.4		1.27	0.015		0.050
M			0.6			0.023
S	8 (max.)					

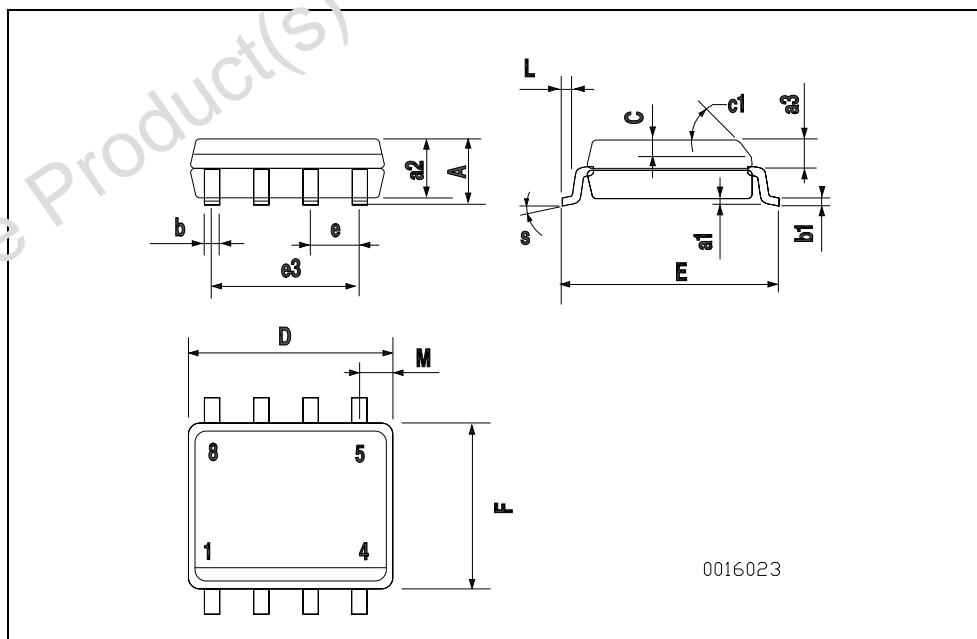

0016023

## 5 Revision history

**Table 8. Document revision history**

Date	Revision	Changes
22-Jun2004	1	First release
03-Aug-2004	2	Some value change in <a href="#">Table 2</a>
08-Mar-2005	3	Complete version
17-Mar-2005	4	Ron value change (see <a href="#">Table 4</a> )
23-Jun-2005	5	New Rg value on <a href="#">Table 5</a>
30-Mar-2006	6	The document has been reformatted
17-Apr-2007	7	New parameters on <a href="#">Table 5</a> and new <a href="#">Figure 20</a>
23-Apr-2007	8	Modified value on <a href="#">Table 2</a>
26-Nov-2007	9	Modified marking on <a href="#">Table 1</a>

**Please Read Carefully:**

Information in this document is provided solely in connection with ST products. STMicroelectronics NV and its subsidiaries ("ST") reserve the right to make changes, corrections, modifications or improvements, to this document, and the products and services described herein at any time, without notice.

All ST products are sold pursuant to ST's terms and conditions of sale.

Purchasers are solely responsible for the choice, selection and use of the ST products and services described herein, and ST assumes no liability whatsoever relating to the choice, selection or use of the ST products and services described herein.

No license, express or implied, by estoppel or otherwise, to any intellectual property rights is granted under this document. If any part of this document refers to any third party products or services it shall not be deemed a license grant by ST for the use of such third party products or services, or any intellectual property contained therein or considered a warranty covering the use in any manner whatsoever of such third party products or services or any intellectual property contained therein.

**UNLESS OTHERWISE SET FORTH IN ST'S TERMS AND CONDITIONS OF SALE ST DISCLAIMS ANY EXPRESS OR IMPLIED WARRANTY WITH RESPECT TO THE USE AND/OR SALE OF ST PRODUCTS INCLUDING WITHOUT LIMITATION IMPLIED WARRANTIES OF MERCHANTABILITY, FITNESS FOR A PARTICULAR PURPOSE (AND THEIR EQUIVALENTS UNDER THE LAWS OF ANY JURISDICTION), OR INFRINGEMENT OF ANY PATENT, COPYRIGHT OR OTHER INTELLECTUAL PROPERTY RIGHT.**

**UNLESS EXPRESSLY APPROVED IN WRITING BY AN AUTHORIZED REPRESENTATIVE OF ST, ST PRODUCTS ARE NOT DESIGNED, AUTHORIZED OR WARRANTED FOR USE IN MILITARY, AIR CRAFT, SPACE, LIFE SAVING, OR LIFE SUSTAINING APPLICATIONS, NOR IN PRODUCTS OR SYSTEMS, WHERE FAILURE OR MALFUNCTION MAY RESULT IN PERSONAL INJURY, DEATH, OR SEVERE PROPERTY OR ENVIRONMENTAL DAMAGE.**

Resale of ST products with provisions different from the statements and/or technical features set forth in this document shall immediately void any warranty granted by ST for the ST product or service described herein and shall not create or extend in any manner whatsoever, any liability of ST.

ST and the ST logo are trademarks or registered trademarks of ST in various countries.

Information in this document supersedes and replaces all information previously supplied.

The ST logo is a registered trademark of STMicroelectronics. All other names are the property of their respective owners.

© 2007 STMicroelectronics - All rights reserved

STMicroelectronics group of companies

Australia - Belgium - Brazil - Canada - China - Czech Republic - Finland - France - Germany - Hong Kong - India - Israel - Italy - Japan - Malaysia - Malta - Morocco - Singapore - Spain - Sweden - Switzerland - United Kingdom - United States of America

[www.st.com](http://www.st.com)