



Chipsmall Limited consists of a professional team with an average of over 10 year of expertise in the distribution of electronic components. Based in Hongkong, we have already established firm and mutual-benefit business relationships with customers from,Europe,America and south Asia,supplying obsolete and hard-to-find components to meet their specific needs.

With the principle of “Quality Parts,Customers Priority,Honest Operation,and Considerate Service”,our business mainly focus on the distribution of electronic components. Line cards we deal with include Microchip,ALPS,ROHM,Xilinx,Pulse,ON,Everlight and Freescale. Main products comprise IC,Modules,Potentiometer,IC Socket,Relay,Connector.Our parts cover such applications as commercial,industrial, and automotives areas.

We are looking forward to setting up business relationship with you and hope to provide you with the best service and solution. Let us make a better world for our industry!



Contact us

Tel: +86-755-8981 8866 Fax: +86-755-8427 6832

Email & Skype: info@chipsmall.com Web: www.chipsmall.com

Address: A1208, Overseas Decoration Building, #122 Zhenhua RD., Futian, Shenzhen, China





STTA806D/DI/G

TURBOSWITCH ULTRA-FAST HIGH VOLTAGE DIODE

MAIN PRODUCTS CHARACTERISTICS

$I_{F(AV)}$	8A
V_{RRM}	600V
t_{rr} (typ)	25ns
V_F (max)	1.5V

FEATURES AND BENEFITS

- SPECIFIC TO "FREEWHEEL MODE" OPERATIONS: FREEWHEEL OR BOOSTER DIODE
- ULTRA-FAST AND SOFT RECOVERY
- VERY LOW OVERALL POWER LOSSES IN BOTH THE DIODE AND THE COMPANION TRANSISTOR
- HIGH FREQUENCY OPERATIONS
- INSULATED PACKAGE : TO-220AC
Electrical insulation : 2500V_{RMS}
Capacitance < 7 pF

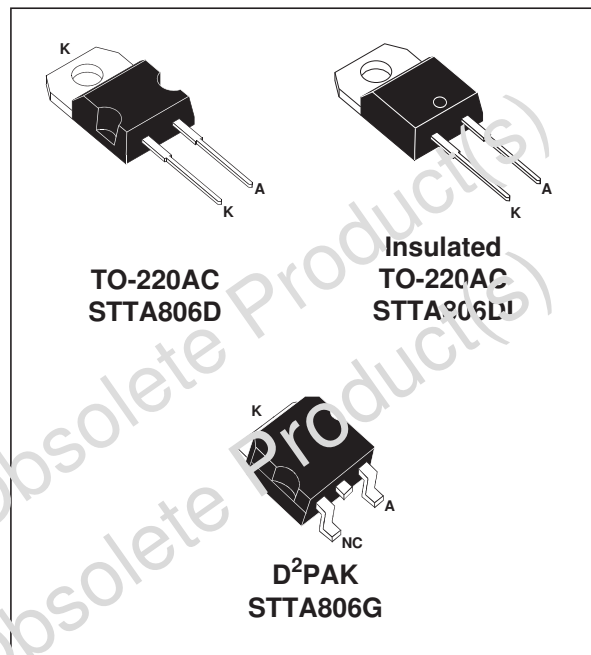

DESCRIPTION

The TURBOSWITCH is a very high performance series of ultra-fast high voltage power diodes from 600V to 1200V. TURBOSWITCH family, drastically cuts losses in both the diode and the associated switching IGBT or MOSFET in all "freewheel mode" operations and is particularly suitable and efficient in motor

control freewheel applications and in booster diode applications in power factor control circuitries.

Packaged either in TO-220AC, insulated TO-220AC or in D²PAK, these 600V devices are particularly intended for use on 240V domestic mains.

ABSOLUTE RATINGS (limiting values)

Symbol	Parameter	Value	Unit	
V_{RRM}	Repetitive peak reverse voltage	600	V	
V_{RSM}	Non repetitive peak reverse voltage	600	V	
$I_{F(RMS)}$	RMS forward current	TO-220AC / D ² PAK	30	A
		TO-220AC ins.	20	A
I_{FRM}	Repetitive peak forward current	$t_p=5ms$ F=5kHz square	110	A
I_{FSM}	Surge non repetitive forward current	$t_p=10$ ms sinusoidal	90	A
T_j	Maximum operating junction temperature	150	°C	
T_{stg}	Storage temperature range	-65 to 150	°C	

TM : TURBOSWITCH is a trademark of STMicroelectronics

STTA806D/DI/G

THERMAL AND POWER DATA

Symbol	Parameter		Conditions	Value	Unit
$R_{th(j-c)}$	Junction to case thermal resistance	TO-220AC / D ² PAK TO-220AC ins.		2.2 3.3	°C/W
P_1	Conduction power dissipation $I_{F(AV)} = 8A$ $\delta = 0.5$	TO-220AC / D ² PAK TO-220AC ins.	$T_c = 118^\circ C$ $T_c = 102^\circ C$	14.5	W
P_{max}	Total power dissipation $P_{max} = P_1 + P_3$ ($P_3 = 10\% P_1$)	TO-220AC / D ² PAK TO-220AC ins.	$T_c = 115^\circ C$ $T_c = 97^\circ C$	16	W

STATIC ELECTRICAL CHARACTERISTICS

Symbol	Parameter	Test conditions		Min	Typ	Max	Unit
V_F^*	Forward voltage drop	$I_F = 8A$	$T_j = 25^\circ C$ $T_j = 125^\circ C$		1.25	1.75 1.5	V V
I_R^{**}	Reverse leakage current	$V_R = 0.8 \times V_{RRM}$	$T_j = 25^\circ C$ $T_j = 125^\circ C$		1.5	100 4	μA mA
V_{to}	Threshold voltage	$I_p < 3 \cdot I_{AV}$	$T_j = 125^\circ C$			1.15	V
r_d	Dynamic resistance					43	m Ω

Test pulse : * $t_p = 380 \mu s$, $\delta < 2\%$
 ** $t_p = 5 ms$, $\delta < 2\%$

To evaluate the maximum conduction losses use the following equation :
 $P = V_{to} \times I_{F(AV)} + r_d \times I_{F(RMS)}^2$

DYNAMIC ELECTRICAL CHARACTERISTICS

TURN-OFF SWITCHING

Symbol	Parameter	Test conditions	Min	Typ	Max	Unit
t_{rr}	Reverse recovery time	$T_j = 25^\circ C$ $I_F = 0.5 A$ $I_R = 1 A$ $I_{rr} = 0.25 A$ $I_F = 1 A$ $di_F/dt = -50 A/\mu s$ $V_R = 30 V$		25	52	ns
I_{RM}	Maximum reverse recovery current	$T_j = 125^\circ C$ $V_R = 400 V$ $I_F = 8 A$ $di_F/dt = -64 A/\mu s$ $di_F/dt = -500 A/\mu s$		14	5.5	A
S factor	Softness factor	$T_j = 125^\circ C$ $V_R = 400 V$ $I_F = 8 A$ $di_F/dt = -500 A/\mu s$		0.47		-

TURN-ON SWITCHING

Symbol	Parameter	Test conditions	Min	Typ	Max	Unit
t_{fr}	Forward recovery time	$T_j = 25^\circ C$ $I_F = 8 A$, $di_F/dt = 64 A/\mu s$ measured at, $1.1 \times V_{Fmax}$			500	ns
V_{Fp}	Peak forward voltage	$T_j = 25^\circ C$ $I_F = 8 A$, $di_F/dt = 64 A/\mu s$			10	V

Fig. 1: Conduction losses versus average current.

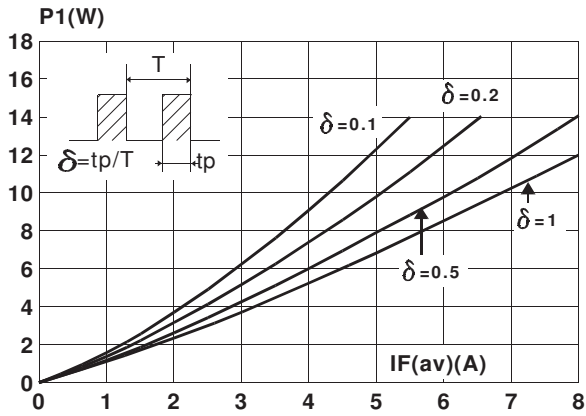

Fig. 2: Forward voltage drop versus forward current.

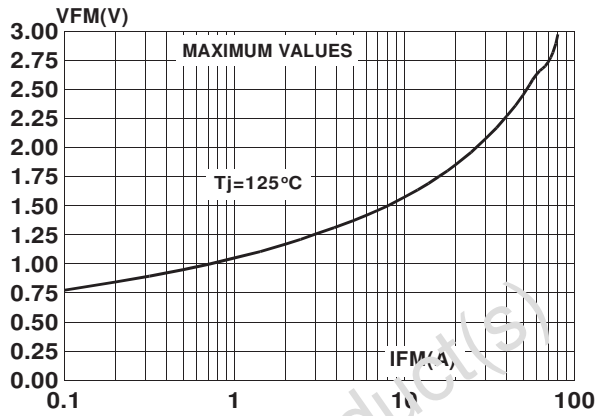

Fig. 3: Relative variation of thermal transient impedance junction to case versus pulse duration.

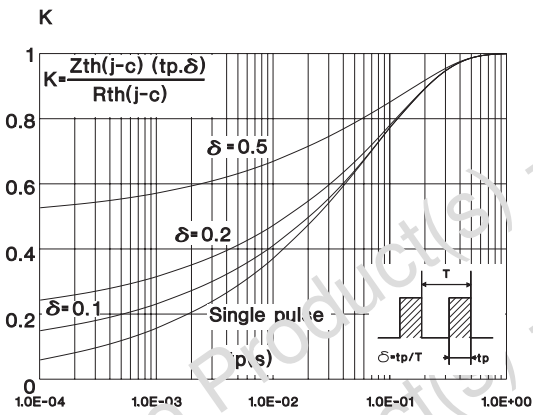

Fig. 4: Peak reverse recovery current versus diF/dt.

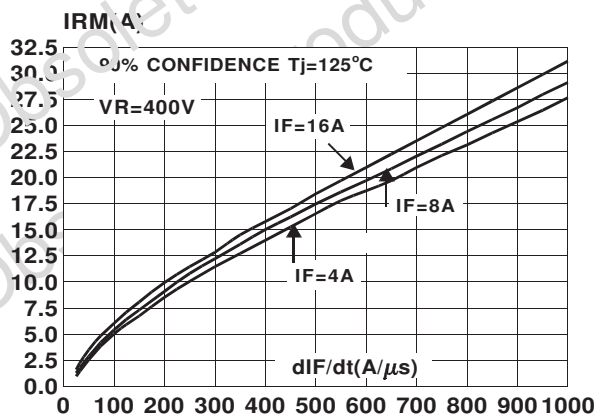

Fig. 5: Reverse recovery time versus diF/dt.

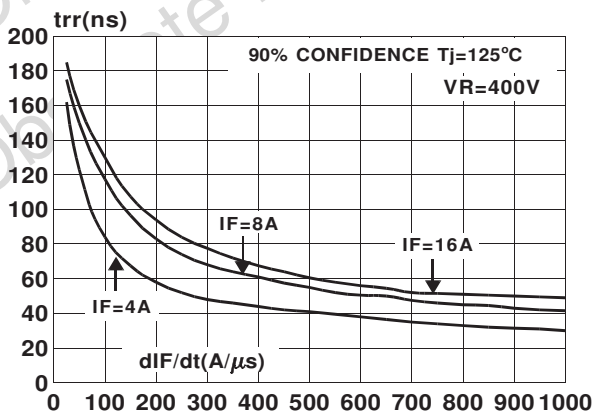

Fig. 6: Softness factor (tb/ta) versus diF/dt.

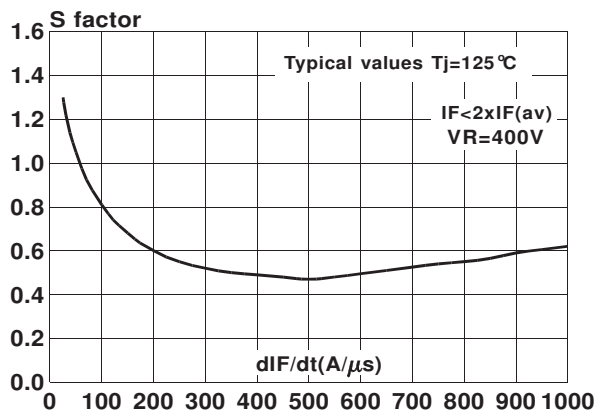

Fig. 7: Relative variation of dynamic parameters versus junction temperature (reference $T_j=125^\circ\text{C}$).

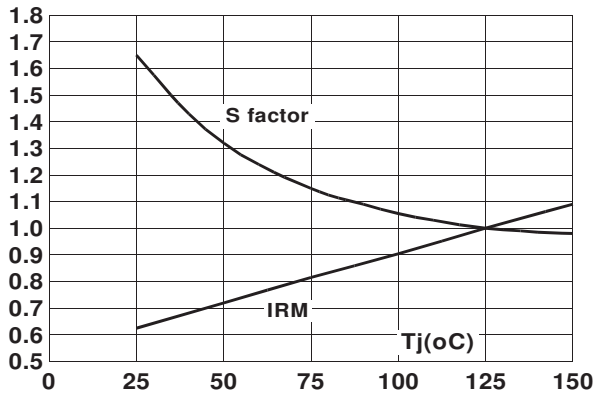

Fig. 8: Transient peak forward voltage versus dI_F/dt .

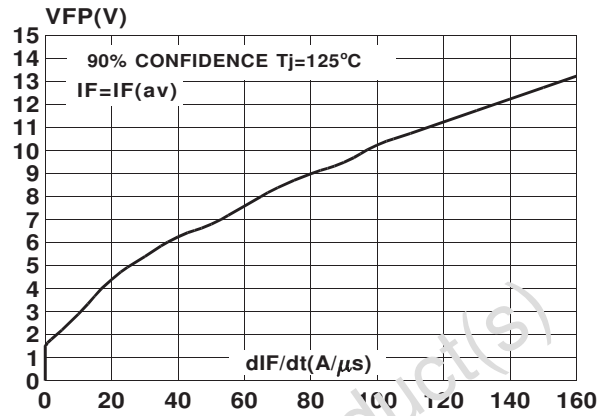
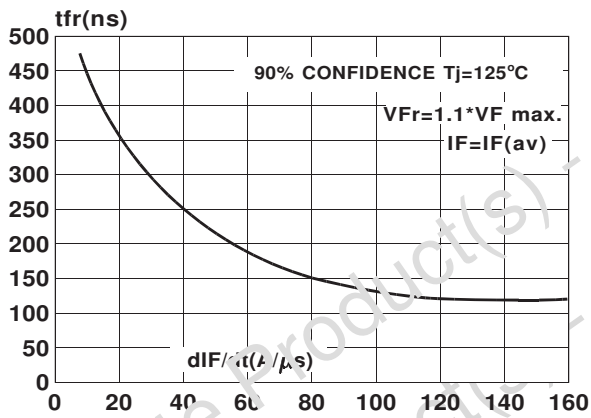

Fig. 9: Forward recovery time versus dI_F/dt .



APPLICATION DATA

The TURBOSWITCH is especially designed to provide the lowest overall power losses in any "FREEWHEEL Mode" application (Fig.A) considering both the diode and the companion

transistor, thus optimizing the overall performance in the end application. The way of calculating the power losses is given below:

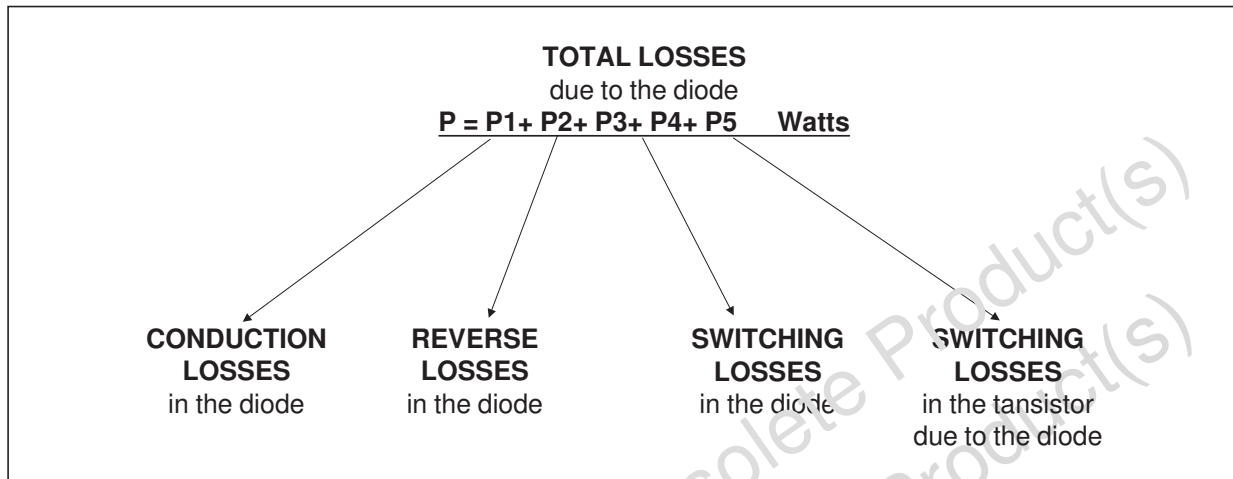
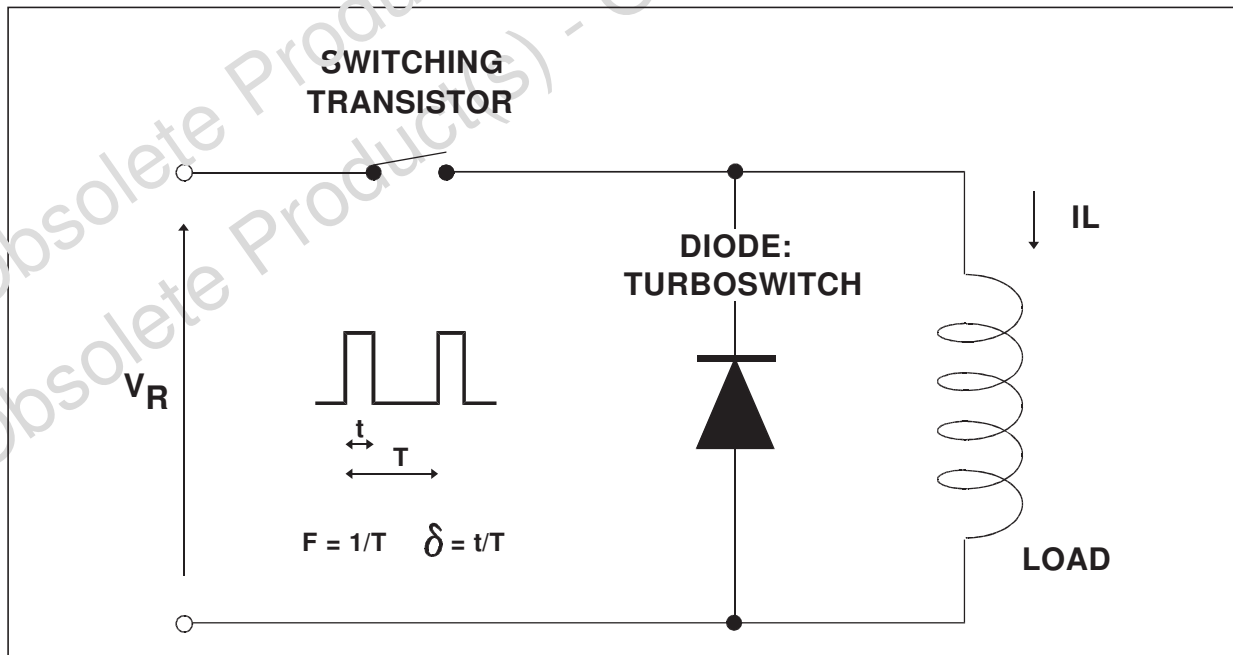
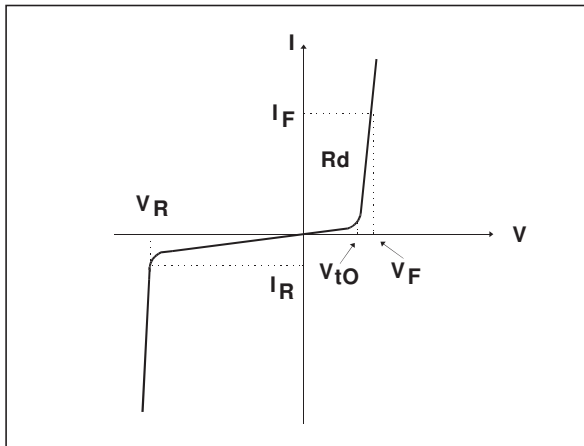

Fig. A : "FREEWHEEL" MODE



APPLICATION DATA (Cont'd)

Fig. B: STATIC CHARACTERISTICS



Conduction losses :

$$P1 = V_{t0} \cdot I_F(AV) + R_d \cdot I_F^2(RMS)$$

Reverse losses :

$$P2 = V_R \cdot I_R \cdot (1 - \delta)$$

Fig. C: TURN-OFF CHARACTERISTICS

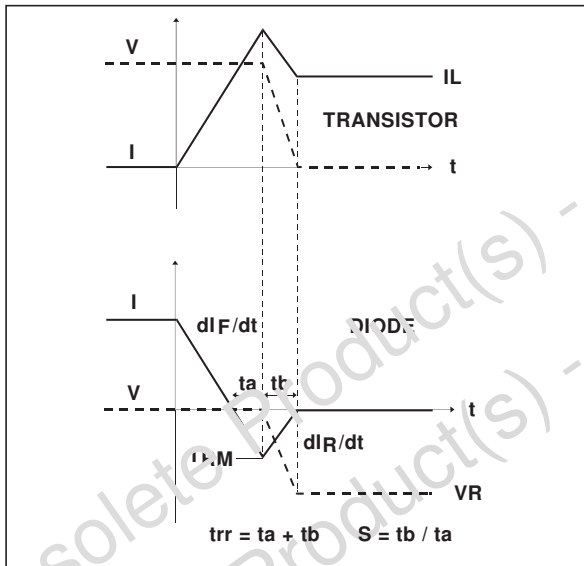

Turn-on losses :

(in the transistor, due to the diode)

$$P5 = \frac{V_R \times I_{RM}^2 \times (3 + 2 \times S) \times F}{6 \times dI_F / dt} + \frac{V_R \times I_{RM} \times I_L \times (S + 2) \times F}{2 \times dI_F / dt}$$

Turn-off losses (in the diode) :

$$P3 = \frac{V_R \times I_{RM}^2 \times S \times F}{6 \times dI_F / dt}$$

P3 and P5 are suitable for power MOSFET and IGBT

Fig. D: TURN-ON CHARACTERISTICS

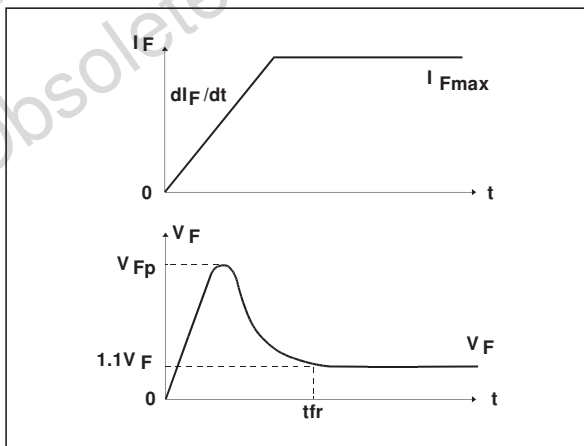

Turn-on losses :

$$P4 = 0.4 (V_{FP} - V_F) \cdot I_{Fmax} \cdot t_{fr} \cdot F$$

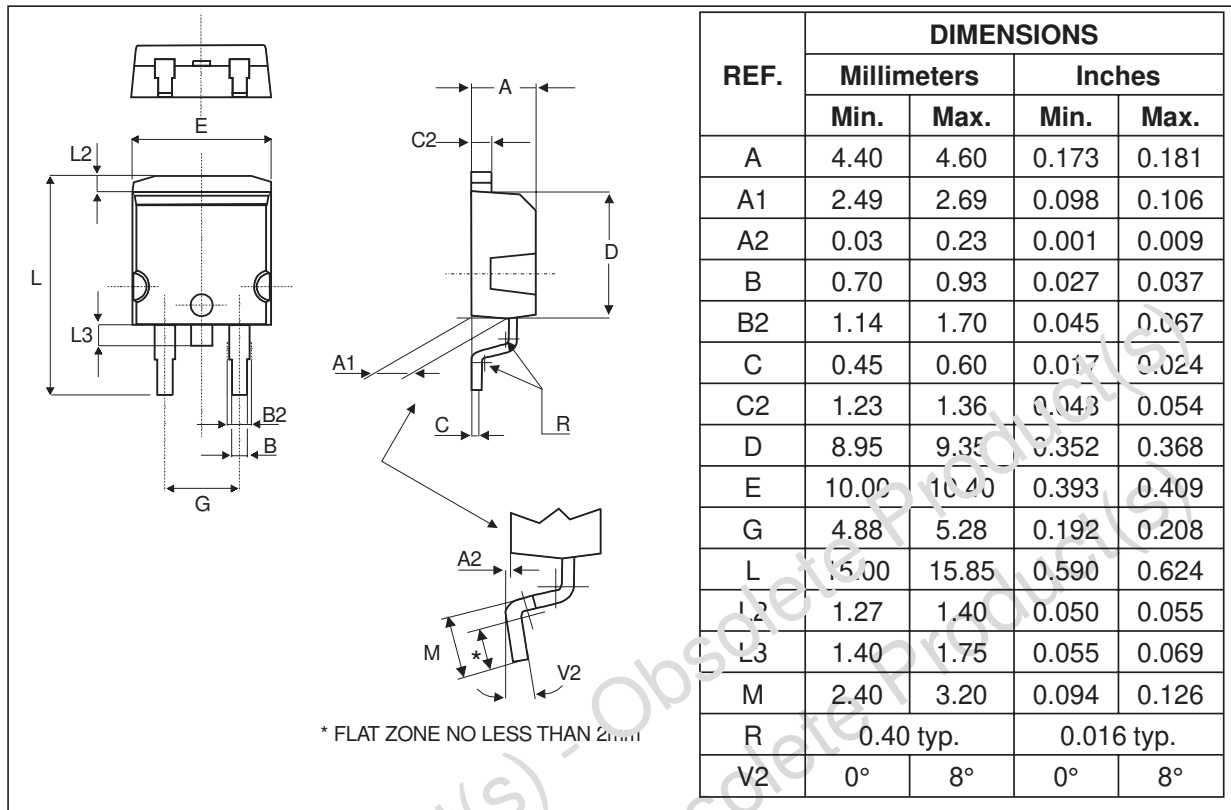
PACKAGE DATA
D²PAK

FOOTPRINT DIMENSIONS (in millimeters)

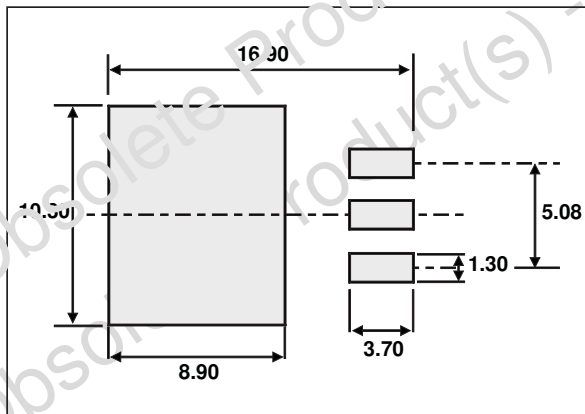
■ Cooling method : by conduction (C)

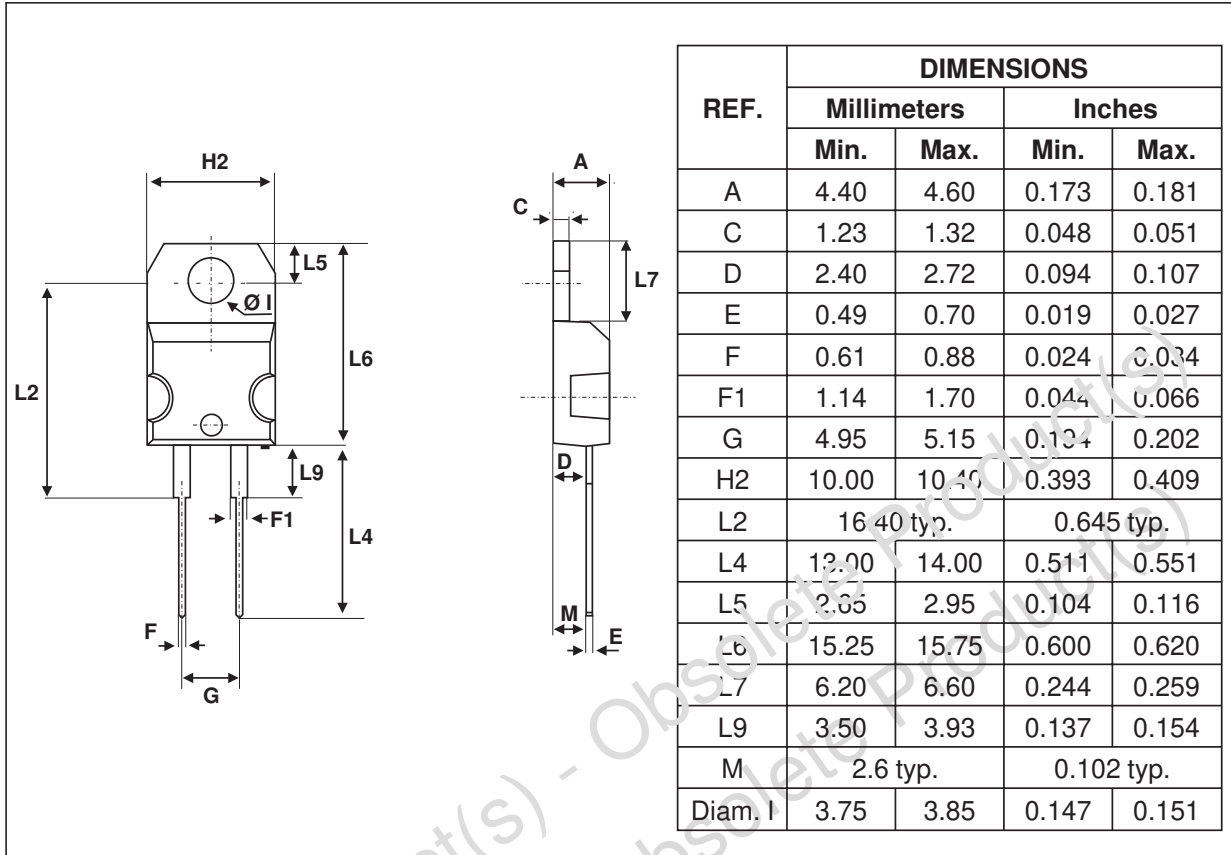

STTA806D/DI/G

PACKAGE DATA
TO-220AC (JEDEC OUTLINE)



- Cooling method : by conduction (C)
- Recommended torque value : 0.55m.N
- Maximum torque value : 0.7m.N

PACKAGE DATA
INSULATED TO-220AC

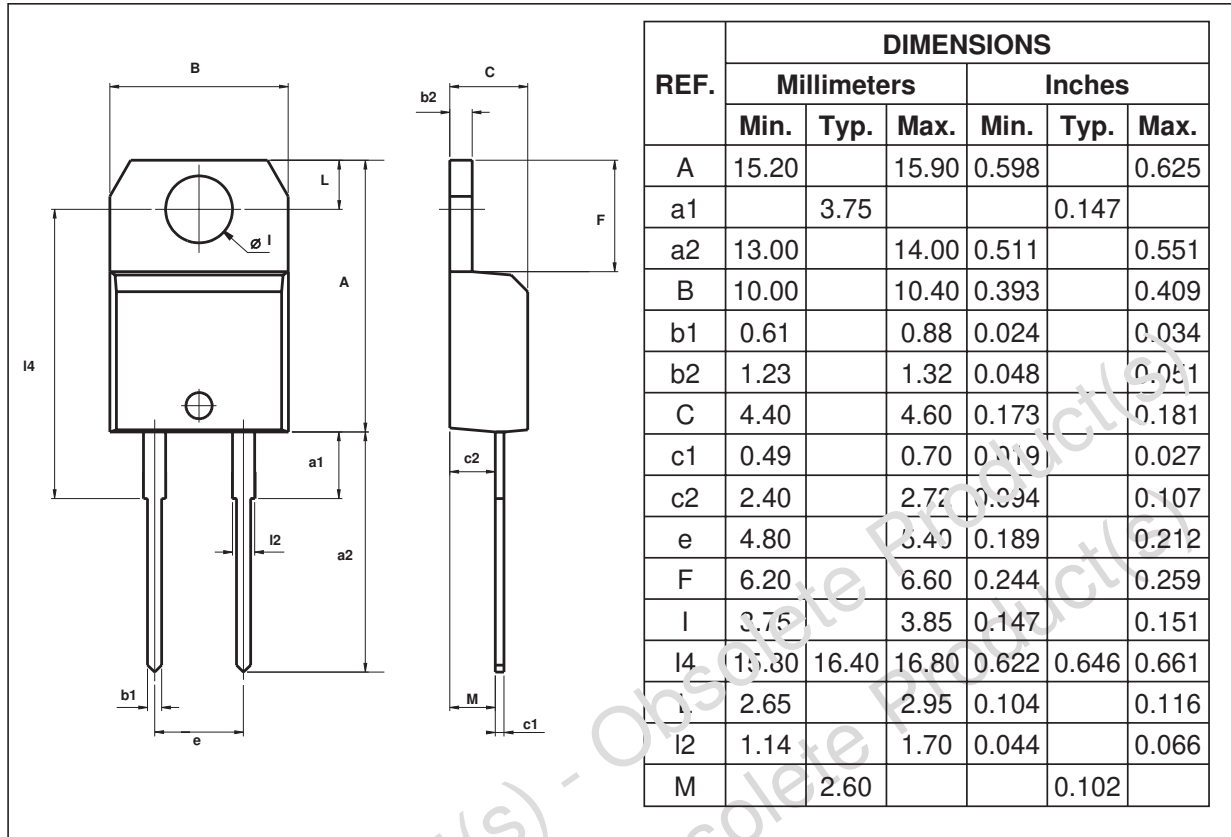

- Cooling method : by conduction (C)
- Recommended torque value : 0.3m.N
- Maximum torque value : 1m.N

Ordering type	Marking	Package	Weight	Base qty	Delivery mode
STTA806D	STTA806D	TO-220AC	1.86g	50	Tube
STTA806DI	STTA806DI	TO-220AC Ins.	1.86g	250	Bulk
STTA806G	STTA806G	D ² PAK	1.48g	50	Tube
STTA806G-TR	STTA806G	D ² PAK	1.48g	500	Tape & reel

- Epoxy meets UL94,V0

Information furnished is believed to be accurate and reliable. However, STMicroelectronics assumes no responsibility for the consequences of use of such information nor for any infringement of patents or other rights of third parties which may result from its use. No license is granted by implication or otherwise under any patent or patent rights of STMicroelectronics. Specifications mentioned in this publication are subject to change without notice. This publication supersedes and replaces all information previously supplied. STMicroelectronics products are not authorized for use as critical components in life support devices or systems without express written approval of STMicroelectronics.

The ST logo is a registered trademark of STMicroelectronics

© 2002 STMicroelectronics - Printed in Italy - All rights reserved.

STMicroelectronics GROUP OF COMPANIES

Australia - Brazil - Canada - China - Finland - France - Germany
Hong Kong - India - Israel - Italy - Japan - Malaysia - Malta - Morocco - Singapore
Spain - Sweden - Switzerland - United Kingdom - United States.

<http://www.st.com>