



Chipsmall Limited consists of a professional team with an average of over 10 year of expertise in the distribution of electronic components. Based in Hongkong, we have already established firm and mutual-benefit business relationships with customers from,Europe,America and south Asia,supplying obsolete and hard-to-find components to meet their specific needs.

With the principle of “Quality Parts,Customers Priority,Honest Operation,and Considerate Service”,our business mainly focus on the distribution of electronic components. Line cards we deal with include Microchip,ALPS,ROHM,Xilinx,Pulse,ON,Everlight and Freescale. Main products comprise IC,Modules,Potentiometer,IC Socket,Relay,Connector.Our parts cover such applications as commercial,industrial, and automotives areas.

We are looking forward to setting up business relationship with you and hope to provide you with the best service and solution. Let us make a better world for our industry!



## Contact us

Tel: +86-755-8981 8866 Fax: +86-755-8427 6832

Email & Skype: info@chipsmall.com Web: www.chipsmall.com

Address: A1208, Overseas Decoration Building, #122 Zhenhua RD., Futian, Shenzhen, China



## N-channel 600 V, 0.065 $\Omega$ typ., 40 A MDmesh™ DM2 Power MOSFET in a TO-247 package

Datasheet - production data

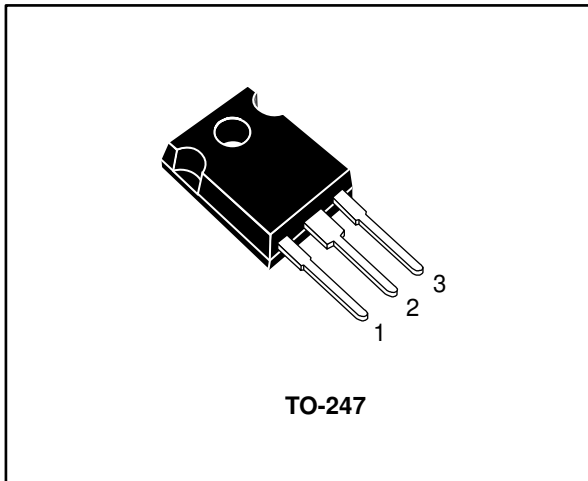
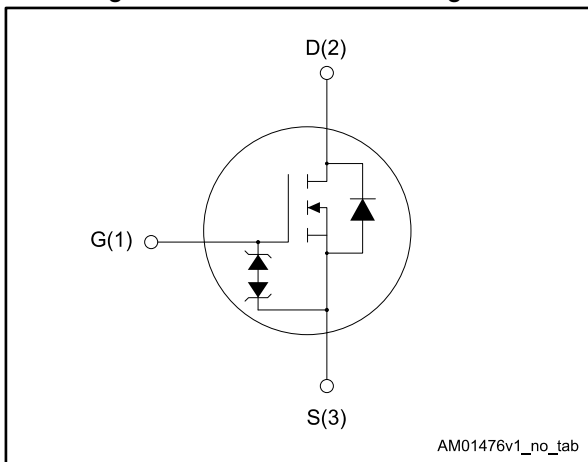

Figure 1: Internal schematic diagram



### Features

| Order code  | V <sub>DS</sub> | R <sub>DS(on)</sub> max. | I <sub>D</sub> |
|-------------|-----------------|--------------------------|----------------|
| STW48N60DM2 | 600 V           | 0.079 $\Omega$           | 40 A           |

- Fast-recovery body diode
- Extremely low gate charge and input capacitance
- Low on-resistance
- 100% avalanche tested
- Extremely high dv/dt ruggedness
- Zener-protected

### Applications

- Switching applications

### Description

This high voltage N-channel Power MOSFET is part of the MDmesh™ DM2 fast recovery diode series. It offers very low recovery charge ( $Q_{rr}$ ) and time ( $t_{rr}$ ) combined with low  $R_{DS(on)}$ , rendering it suitable for the most demanding high efficiency converters and ideal for bridge topologies and ZVS phase-shift converters.

Table 1: Device summary

| Order code  | Marking  | Package | Packing |
|-------------|----------|---------|---------|
| STW48N60DM2 | 48N60DM2 | TO-247  | Tube    |

---

## Contents

|          |  |           |
|----------|--|-----------|
| <b>1</b> | <b>Electrical ratings .....</b>              | <b>3</b>  |
| <b>2</b> | <b>Electrical characteristics .....</b>      | <b>4</b>  |
|          | 2.1 Electrical characteristics (curves)..... | 6         |
| <b>3</b> | <b>Test circuits .....</b>                   | <b>8</b>  |
| <b>4</b> | <b>Package information .....</b>             | <b>9</b>  |
|          | 4.1 TO-247 package information.....          | 9         |
| <b>5</b> | <b>Revision history .....</b>                | <b>11</b> |

# 1 Electrical ratings

**Table 2: Absolute maximum ratings**

| Symbol         | Parameter  | Value      | Unit |
|----------------|--|------------|------|
| $V_{GS}$       | Gate-source voltage                                      | ±25        | V    |
| $I_D$          | Drain current (continuous) at $T_{case} = 25\text{ °C}$  | 40         | A    |
|                | Drain current (continuous) at $T_{case} = 100\text{ °C}$ | 25         |      |
| $I_{DM}^{(1)}$ | Drain current (pulsed)                                   | 160        | A    |
| $P_{TOT}$      | Total dissipation at $T_{case} = 25\text{ °C}$           | 300        | W    |
| $dv/dt^{(2)}$  | Peak diode recovery voltage slope                        | 50         | V/ns |
| $dv/dt^{(3)}$  | MOSFET $dv/dt$ ruggedness                                |            |      |
| $T_{stg}$      | Storage temperature                                      | -55 to 150 | °C   |
| $T_j$          | Operating junction temperature                           |            |      |

**Notes:**

(1) Pulse width is limited by safe operating area.

(2)  $I_{SD} \leq 40\text{ A}$ ,  $di/dt=900\text{ A}/\mu\text{s}$ ;  $V_{DS\text{ peak}} < V_{(BR)DSS}$ ,  $V_{DD} = 400\text{ V}$ .

(3)  $V_{DS} \leq 480\text{ V}$ .

**Table 3: Thermal data**

| Symbol         | Parameter                           | Value | Unit |
|----------------|-------------------------------------|-------|------|
| $R_{thj-case}$ | Thermal resistance junction-case    | 0.42  | °C/W |
| $R_{thj-amb}$  | Thermal resistance junction-ambient | 50    |      |

**Table 4: Avalanche characteristics**

| Symbol   | Parameter  | Value | Unit |
|----------|--|-------|------|
| $I_{AR}$ | Avalanche current, repetitive or not repetitive (Pulse width limited by $T_{jmax}$ )                     | 7     | A    |
| $E_{AR}$ | Single pulse avalanche energy (starting $T_j = 25\text{ °C}$ , $I_D = I_{AR}$ , $V_{DD} = 50\text{ V}$ ) | 950   | mJ   |

## 2 Electrical characteristics

( $T_{\text{case}} = 25\text{ °C}$  unless otherwise specified)

**Table 5: Static**

| Symbol        | Parameter                         | Test conditions  | Min. | Typ.  | Max.    | Unit          |
|---------------|-----------------------------------|--|------|-------|---------|---------------|
| $V_{(BR)DSS}$ | Drain-source breakdown voltage    | $V_{GS} = 0\text{ V}$ , $I_D = 1\text{ mA}$  | 600  |       |         | V             |
| $I_{DSS}$     | Zero gate voltage drain current   | $V_{GS} = 0\text{ V}$ , $V_{DS} = 600\text{ V}$  |      |       | 1       | $\mu\text{A}$ |
|               |                                   | $V_{GS} = 0\text{ V}$ , $V_{DS} = 600\text{ V}$ ,<br>$T_{\text{case}} = 125\text{ °C}$ |      |       | 100     |               |
| $I_{GSS}$     | Gate-body leakage current         | $V_{DS} = 0\text{ V}$ , $V_{GS} = \pm 25\text{ V}$                                     |      |       | $\pm 5$ | $\mu\text{A}$ |
| $V_{GS(th)}$  | Gate threshold voltage            | $V_{DS} = V_{GS}$ , $I_D = 250\text{ }\mu\text{A}$                                     | 3    | 4     | 5       | V             |
| $R_{DS(on)}$  | Static drain-source on-resistance | $V_{GS} = 10\text{ V}$ , $I_D = 20\text{ A}$   |      | 0.065 | 0.079   | $\Omega$      |

**Table 6: Dynamic**

| Symbol                     | Parameter                     | Test conditions   | Min. | Typ. | Max. | Unit          |
|----------------------------|-------------------------------|---|------|------|------|---------------|
| $C_{iss}$                  | Input capacitance             | $V_{DS} = 100\text{ V}$ , $f = 1\text{ MHz}$ , $I_D = 0\text{ A}$   | -    | 3250 | -    | $\mu\text{F}$ |
| $C_{oss}$                  | Output capacitance            |   | -    | 142  | -    |               |
| $C_{rss}$                  | Reverse transfer capacitance  |   | -    | 4.5  | -    |               |
| $C_{oss\text{ eq.}}^{(1)}$ | Equivalent output capacitance | $V_{DS} = 0\text{ to }480\text{ V}$ , $V_{GS} = 0\text{ V}$   | -    | 258  | -    | $\mu\text{F}$ |
| $R_G$                      | Intrinsic gate resistance     | $f = 1\text{ MHz}$ , $I_D = 0\text{ A}$   | -    | 4    | -    | $\Omega$      |
| $Q_g$                      | Total gate charge             | $V_{DD} = 480\text{ V}$ , $I_D = 40\text{ A}$ , $V_{GS} = 10\text{ V}$<br>(see <a href="#">Figure 14: "Test circuit for gate charge behavior"</a> ) | -    | 70   | -    | nC            |
| $Q_{gs}$                   | Gate-source charge            |   | -    | 18   | -    |               |
| $Q_{gd}$                   | Gate-drain charge             |   | -    | 28   | -    |               |

**Notes:**

<sup>(1)</sup>  $C_{oss\text{ eq.}}$  is defined as a constant equivalent capacitance giving the same charging time as  $C_{oss}$  when  $V_{DS}$  increases from 0 to 80%  $V_{DSS}$ .

**Table 7: Switching times**

| Symbol       | Parameter           | Test conditions   | Min. | Typ. | Max. | Unit |
|--------------|---------------------|---|------|------|------|------|
| $t_{d(on)}$  | Turn-on delay time  | $V_{DD} = 300\text{ V}$ , $I_D = 20\text{ A}$ , $R_G = 4.7\text{ }\Omega$ ,<br>$V_{GS} = 10\text{ V}$ (see <a href="#">Figure 13: "Test circuit for resistive load switching times"</a> and ) | -    | 27   | -    | ns   |
| $t_r$        | Rise time           |   | -    | 27   | -    |      |
| $t_{d(off)}$ | Turn-off delay time |   | -    | 131  | -    |      |
| $t_f$        | Fall time           |   | -    | 9.8  | -    |      |

Table 8: Source-drain diode

| Symbol          | Parameter                     | Test conditions  | Min. | Typ. | Max. | Unit          |
|-----------------|-------------------------------|--|------|------|------|---------------|
| $I_{SD}^{(1)}$  | Source-drain current          |  | -    |      | 40   | A             |
| $I_{SDM}^{(2)}$ | Source-drain current (pulsed) |  | -    |      | 160  | A             |
| $V_{SD}^{(3)}$  | Forward on voltage            | $V_{GS} = 0 \text{ V}$ , $I_{SD} = 40 \text{ A}$   | -    |      | 1.6  | V             |
| $t_{rr}$        | Reverse recovery time         | $I_{SD} = 40 \text{ A}$ , $di/dt = 100 \text{ A}/\mu\text{s}$ , $V_{DD} = 60 \text{ V}$<br>(see <a href="#">Figure 15: "Test circuit for inductive load switching and diode recovery times"</a> )                                      | -    | 140  |      | ns            |
| $Q_{rr}$        | Reverse recovery charge       |  | -    | 0.7  |      | $\mu\text{C}$ |
| $I_{RRM}$       | Reverse recovery current      |  | -    | 10   |      | A             |
| $t_{rr}$        | Reverse recovery time         | $I_{SD} = 40 \text{ A}$ , $di/dt = 100 \text{ A}/\mu\text{s}$ , $V_{DD} = 60 \text{ V}$ ,<br>$T_j = 150 \text{ }^\circ\text{C}$ (see <a href="#">Figure 15: "Test circuit for inductive load switching and diode recovery times"</a> ) | -    | 256  |      | ns            |
| $Q_{rr}$        | Reverse recovery charge       |  | -    | 2.5  |      | $\mu\text{C}$ |
| $I_{RRM}$       | Reverse recovery current      |  | -    | 20   |      | A             |

**Notes:**

- (1) Limited by maximum junction temperature  
(2) Pulse width is limited by safe operating area.  
(3) Pulse test: pulse duration = 300  $\mu\text{s}$ , duty cycle 1.5%.

Table 9: Gate-source Zener diode

| Symbol        | Parameter                     | Test conditions                                      | Min.     | Typ. | Max. | Unit |
|---------------|-------------------------------|--|----------|------|------|------|
| $V_{(BR)GSO}$ | Gate-source breakdown voltage | $I_{GS} = \pm 250 \mu\text{A}$ , $I_D = 0 \text{ A}$ | $\pm 30$ | -    | -    | V    |

The built-in back-to-back Zener diodes are specifically designed to enhance the ESD performance of the device. The Zener voltage facilitates efficient and cost-effective device integrity protection, thus eliminating the need for additional external componentry.

## 2.2 Electrical characteristics (curves)

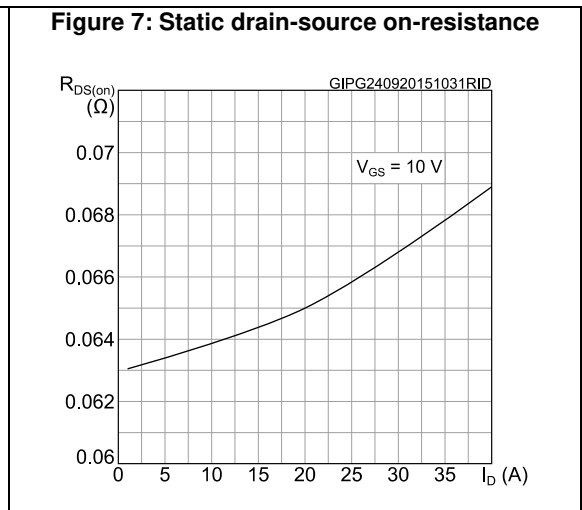
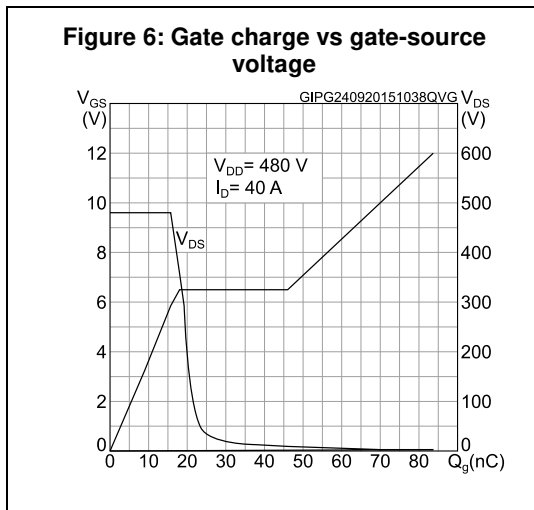
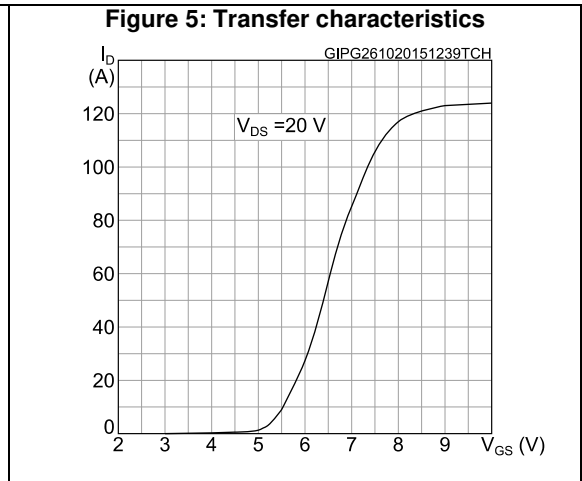
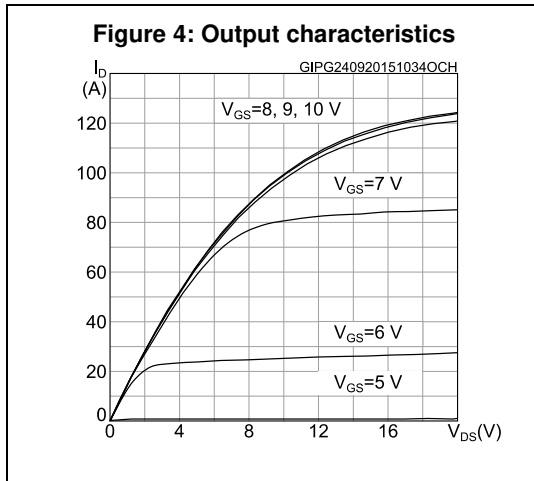
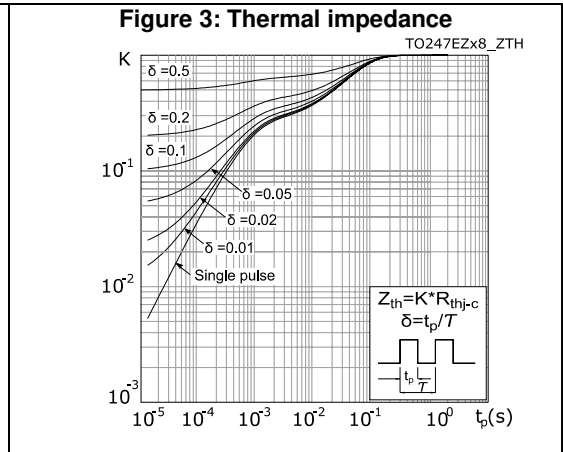
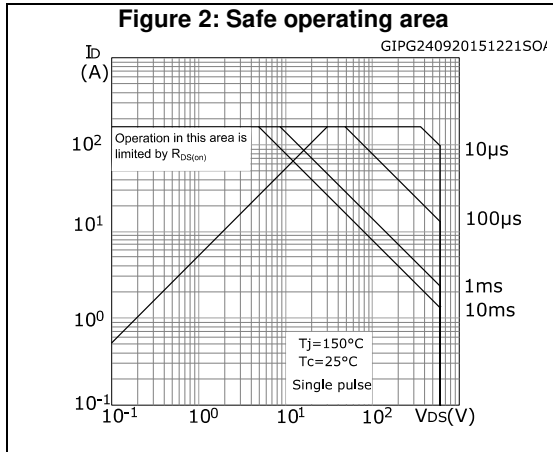

Figure 8: Capacitance variations

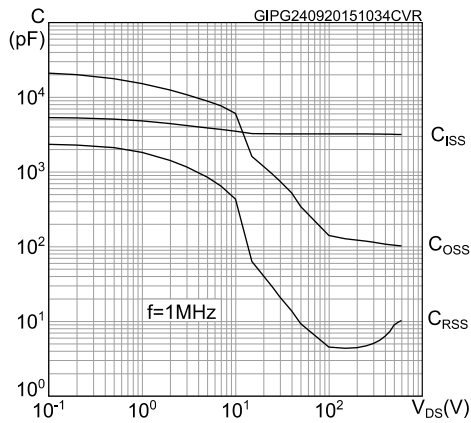

Figure 9: Normalized gate threshold voltage vs temperature

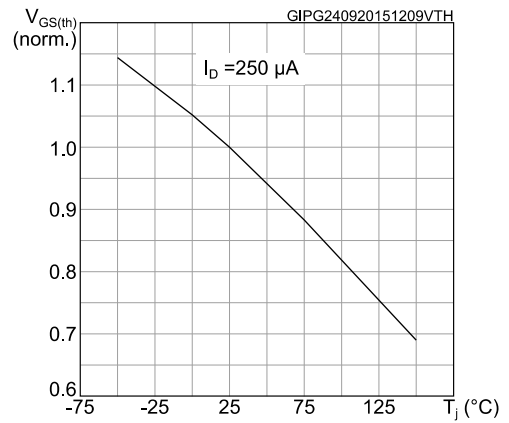

Figure 10: Normalized on-resistance vs temperature

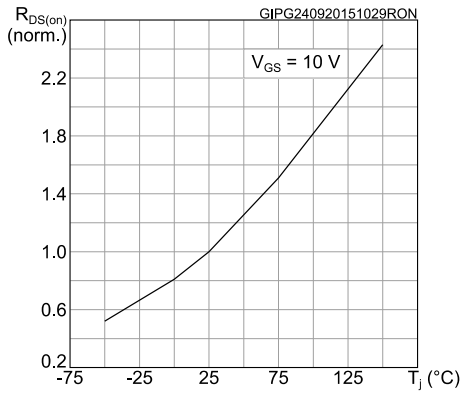

Figure 11: Normalized V(BR)DSS vs temperature

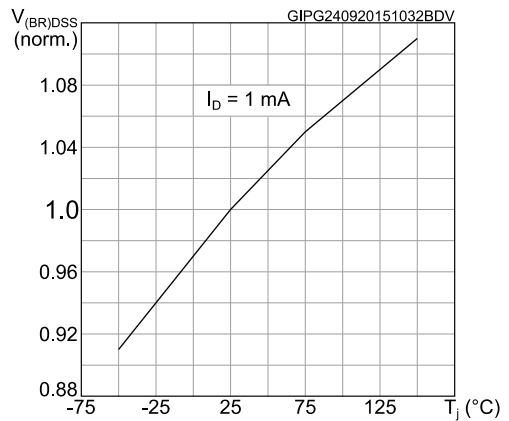
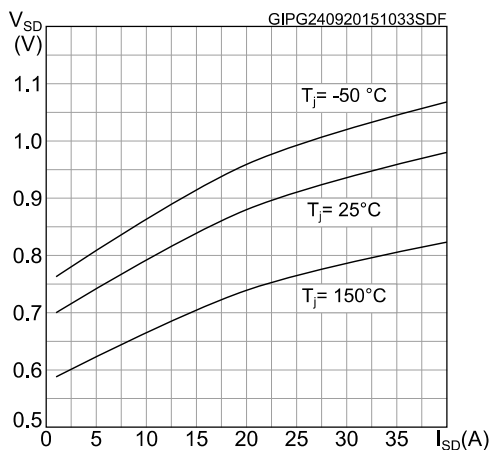
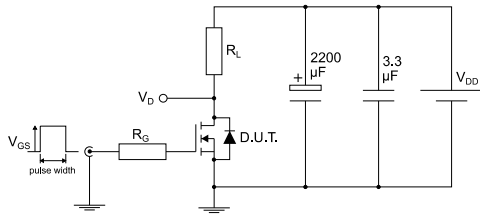

Figure 12: Source- drain diode forward characteristics



### 3 Test circuits

**Figure 13: Test circuit for resistive load switching times**



AM01468v1

**Figure 14: Test circuit for gate charge behavior**

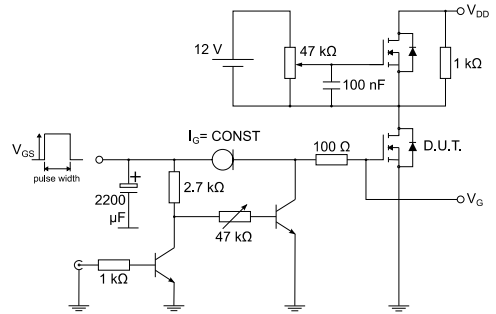

AM01469v1

**Figure 15: Test circuit for inductive load switching and diode recovery times**

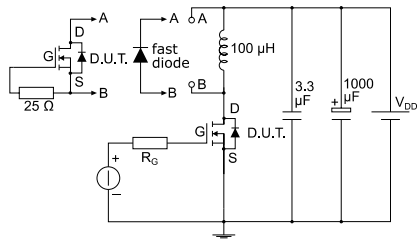

AM01470v1

**Figure 16: Unclamped inductive load test circuit**

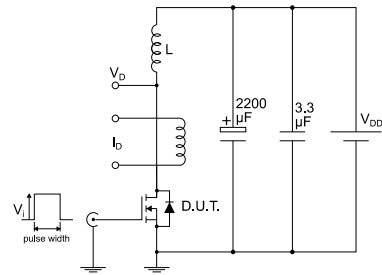

AM01471v1

**Figure 17: Unclamped inductive waveform**

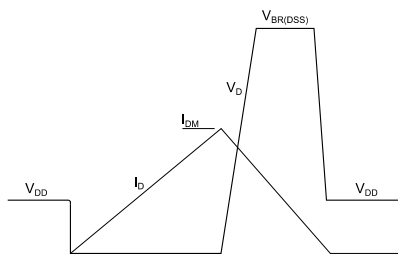

AM01472v1

**Figure 18: Switching time waveform**

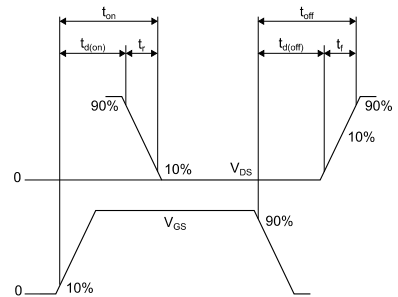

AM01473v1

## 4 Package information

In order to meet environmental requirements, ST offers these devices in different grades of ECOPACK® packages, depending on their level of environmental compliance. ECOPACK® specifications, grade definitions and product status are available at: [www.st.com](http://www.st.com). ECOPACK® is an ST trademark.

### 4.1 TO-247 package information

Figure 19: TO-247 package outline

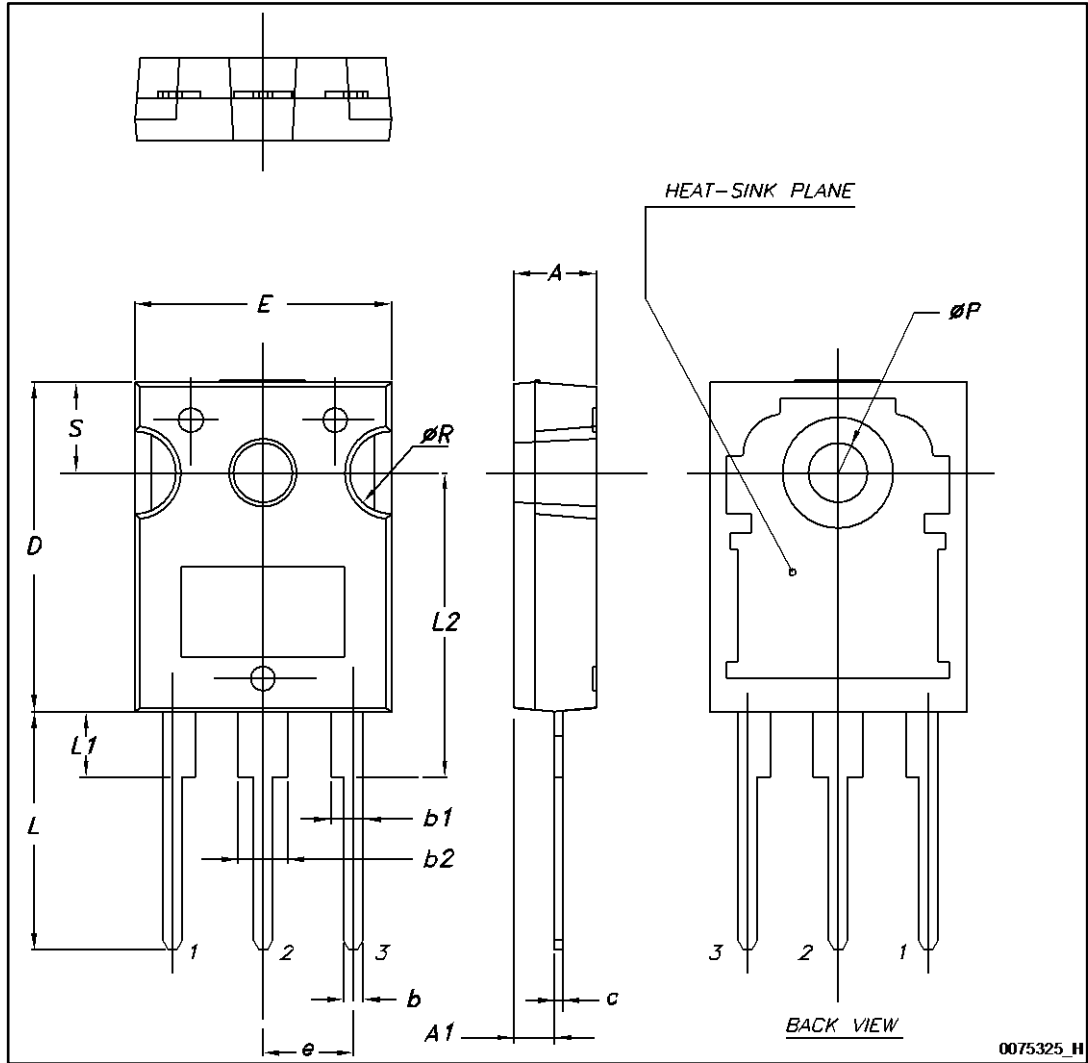

Table 10: TO-247 package mechanical data

| Dim. | mm.   |       |       |
|------|-------|-------|-------|
|      | Min.  | Typ.  | Max.  |
| A    | 4.85  |       | 5.15  |
| A1   | 2.20  |       | 2.60  |
| b    | 1.0   |       | 1.40  |
| b1   | 2.0   |       | 2.40  |
| b2   | 3.0   |       | 3.40  |
| c    | 0.40  |       | 0.80  |
| D    | 19.85 |       | 20.15 |
| E    | 15.45 |       | 15.75 |
| e    | 5.30  | 5.45  | 5.60  |
| L    | 14.20 |       | 14.80 |
| L1   | 3.70  |       | 4.30  |
| L2   |       | 18.50 |       |
| ØP   | 3.55  |       | 3.65  |
| ØR   | 4.50  |       | 5.50  |
| S    | 5.30  | 5.50  | 5.70  |

## 5 Revision history

Table 11: Document revision history

| Date        | Revision | Changes  |
|-------------|----------|--|
| 21-Oct-2014 | 1        | First release.   |
| 29-Oct-2015 | 2        | Document status promoted from preliminary to production data.<br>Modified: title<br>Modified: $V_{DS}$ in cover page<br>Modified: Peak diode recovery voltage slope parameter value and <i>note 2</i><br>Modified: $R_{thj-case}$ value in <i>Table 3: "Thermal data"</i><br>Modified: the entire values in <i>Table 4: "Avalanche characteristics"</i><br>Modified: $I_{DSS}$ , $I_{GSS}$ max values and $R_{DS(on)}$ typical value in <i>Table 5: "Static"</i><br>Modified: the entire values in <i>Table 6: "Dynamic"</i> , <i>Table 7: "Switching times"</i><br>and <i>Table 8: "Source-drain diode"</i><br>Added: <i>Table 9: "Gate-source Zener diode"</i><br>Added: <i>Section 2.1: "Electrical characteristics (curves)"</i><br>Minor text changes |

**IMPORTANT NOTICE – PLEASE READ CAREFULLY**

STMicroelectronics NV and its subsidiaries ("ST") reserve the right to make changes, corrections, enhancements, modifications, and improvements to ST products and/or to this document at any time without notice. Purchasers should obtain the latest relevant information on ST products before placing orders. ST products are sold pursuant to ST's terms and conditions of sale in place at the time of order acknowledgement.

Purchasers are solely responsible for the choice, selection, and use of ST products and ST assumes no liability for application assistance or the design of Purchasers' products.

No license, express or implied, to any intellectual property right is granted by ST herein.

Resale of ST products with provisions different from the information set forth herein shall void any warranty granted by ST for such product.

ST and the ST logo are trademarks of ST. All other product or service names are the property of their respective owners.

Information in this document supersedes and replaces information previously supplied in any prior versions of this document.

© 2015 STMicroelectronics – All rights reserved