



Chipsmall Limited consists of a professional team with an average of over 10 year of expertise in the distribution of electronic components. Based in Hongkong, we have already established firm and mutual-benefit business relationships with customers from,Europe,America and south Asia,supplying obsolete and hard-to-find components to meet their specific needs.

With the principle of “Quality Parts,Customers Priority,Honest Operation,and Considerate Service”,our business mainly focus on the distribution of electronic components. Line cards we deal with include Microchip,ALPS,ROHM,Xilinx,Pulse,ON,Everlight and Freescale. Main products comprise IC,Modules,Potentiometer,IC Socket,Relay,Connector.Our parts cover such applications as commercial,industrial, and automotives areas.

We are looking forward to setting up business relationship with you and hope to provide you with the best service and solution. Let us make a better world for our industry!



Contact us

Tel: +86-755-8981 8866 Fax: +86-755-8427 6832

Email & Skype: info@chipsmall.com Web: www.chipsmall.com

Address: A1208, Overseas Decoration Building, #122 Zhenhua RD., Futian, Shenzhen, China



Digital controller for wireless battery charger (WBC) transmitters Qi

1.1.2 A11 certified, PMA compatible

Datasheet - production data



Features

- Digital controller for wireless battery charger transmitter
- Multiple Qi certified and PMA standard compatible
- Support for up to 5 W applications
 - Mobile
 - Wearable, sports gear, medical
 - Remote controllers
- Native support to half-bridge and full bridge topologies
- 5 V supply voltage
- 2 firmware options
 - Turnkey solution for quick design
 - APIs available for application customization^(a)
- Peripherals available via APIs^(a)
 - ADC with 10 bit precision and 1 M Ω input impedance
 - UART
 - I²C master fast/slow speed rate
 - GPIOs

- Memory
 - Flash and E²PROM with read-while-write (RWW) and error correction code (ECC)
 - Program memory: 32 KBytes Flash; data retention 15 years at 85 °C after 10 kcycles at 25 °C
 - Data memory: 1 KByte true data E²PROM; data retention: 15 years at 85 °C after 100 kcycles at 85 °C
 - RAM: 6 KBytes
- Reference design features
 - 2 layers PCBs
 - Active object detection
 - Graphical user interface for application monitoring
 - Evaluation boards
- Operating temperature: -40 °C up to 105 °C
- Package: VFQFPN32

Applications

- Certified Qi A11
 - Evaluation board: STEVAL-ISB027V1
 - Power rate: 5W
 - Input: 5V
- Qi A13^(a)
 - Power rate: 5 W
 - Input: 5 - 16 V, 12 V
- Wearable^(a)
 - Power rate: 2 W
 - Input: 5 V
- PMA^(a)
 - power rate: 5 W
 - input: 5 V

a. Contact local sale representative for further details: see www.st.com.

Contents

1	Description	6
2	Introduction to wireless battery charging systems	8
3	Certified Qi A11 solution	9
	Firmware	9
4	Pinout and pin description	10
4.1	Pinout for STWBC in Qi A11 configuration	10
4.2	Pin description	11
5	Electrical characteristics	13
5.1	Parameter conditions	13
5.1.1	Minimum and maximum values	13
5.1.2	Typical values	13
5.1.3	Typical curves	13
5.1.4	Typical current consumption	13
5.1.5	Loading capacitors	14
5.1.6	Pin output voltage	15
5.2	Absolute maximum ratings	15
5.3	Operating conditions	17
5.3.1	VOUT external capacitor	18
5.3.2	Internal clock sources and timing characteristics	18
5.3.3	Memory characteristics	20
5.3.4	I/O port pin characteristics	21
5.3.5	Typical output level curves	23
5.3.6	Fast pad	25
5.3.7	Reset pin characteristics	27
5.3.8	I ² C interface characteristics	27
5.3.9	10-bit SAR ADC characteristics	28
5.4	EMC characteristics	31
5.4.1	Electrostatic discharge (ESD)	31
5.4.2	Static latch-up	31

6	Thermal characteristics	32
7	Package information	33
	7.1 Package design overview	33
	7.2 Package mechanical data	34
8	Order codes	35
9	Revision history	35

List of tables

Table 1.	Pinout description	11
Table 2.	Voltage characteristics	15
Table 3.	Current characteristics	16
Table 4.	Thermal characteristics	16
Table 5.	General operating conditions	17
Table 6.	Operating conditions at power-up/power-down	17
Table 7.	HSI RC oscillator	18
Table 8.	LSI RC oscillator	19
Table 9.	PLL internal source clock	19
Table 10.	Flash program memory/data E ² PROM memory	20
Table 11.	Voltage DC characteristics	21
Table 12.	Current DC characteristics	22
Table 13.	NRST pin characteristics	27
Table 14.	I ² C interface characteristics	27
Table 15.	ADC characteristics	28
Table 16.	ADC accuracy characteristics at V _{DD} /V _{DDA} 3.3 V	28
Table 17.	ADC accuracy characteristics at V _{DD} /V _{DDA} 5 V	29
Table 18.	ESD absolute maximum ratings	31
Table 19.	Electrical sensitivity	31
Table 20.	Package thermal characteristics	32
Table 21.	VFQFPN32 package dimensions	34
Table 22.	Silicon product order code	35
Table 23.	Document revision history	35

List of figures

Figure 1.	STWBC device architecture	7
Figure 2.	System view of a wireless charging system	8
Figure 3.	STWBC pinout view	10
Figure 4.	Supply current measurement conditions	14
Figure 5.	Pin loading conditions	14
Figure 6.	Pin input voltage	15
Figure 7.	External capacitor C_{VOUT}	18
Figure 8.	V_{OH} standard pad at 3.3 V	23
Figure 9.	V_{OL} standard pad at 3.3 V	23
Figure 10.	V_{OH} standard pad at 5 V	24
Figure 11.	V_{OL} standard pad at 5 V	24
Figure 12.	V_{OH} fast pad at 3.3 V	25
Figure 13.	V_{OL} fast pad at 3.3 V	25
Figure 14.	V_{OH} fast pad at 5 V	26
Figure 15.	V_{OL} fast pad at 5 V	26
Figure 16.	ADC conversion accuracy	30
Figure 17.	VFQFPN32 package outline	33

1 Description

The STWBC is the digital controller for wireless battery charger (WBC) transmitters (TX) from STMicroelectronics, offering the most flexible and efficient solution for controlling power transfer to a receiver (RX) in WBC-enabled applications such as phones, wearables, and other battery powered devices that use electromagnetic induction for recharging.

As a member of the Qi Wireless Power Consortium and the PMA (Power Matters Alliance), ST ensures full compatibility with these leading wireless charging protocols and holds certification for the Qi 1.1.2 A11 standard.

The STWBC performs all the functions for transmitter control: thanks to the internal 96 MHz clock and supporting both half-bridge and full bridge topologies, it is able to precisely control the amount of transmitted power to match the requirements of the receiving unit in terms of maximizing the efficiency of the power transfer.

The STWBC comes with firmware options to offer customers the ability to personalize their end product without the need of external microcontrollers:

- A turnkey Qi 1.1.2 A11 certified solution, fully interoperable with Qi enabled mobile phones.
- API (application programming interface) access to customize the underlying firmware, for example modifying the behavior of the LEDs or GPIOs in response to the receiver behavior and supporting I²C and UART communication within a network.

The STWBC Qi 1.1.2 A11 certified solution is available in the STMicroelectronics STEVAL-ISB027V1 reference design, intended for all Qi compatible receivers such as in Qi enabled mobile phones.

In the reference design the STWBC integrates the foreign object detection (FOD): the digital feedback between TX and RX units allows the detection of metal objects close to the receiver that could result in potential hazards, enabling the STWBC to stop power transmission when such objects are detected.

The reference design is offered together with a complete ecosystem to support customers in building their applications, including the Qi 1.1.2 A11 certified board (STEVAL-ISB027V1), API libraries and documentation to develop software customizations, as well as a comprehensive graphical user interface to monitor real-time performance and diagnostics.

Figure 1. STWBC device architecture

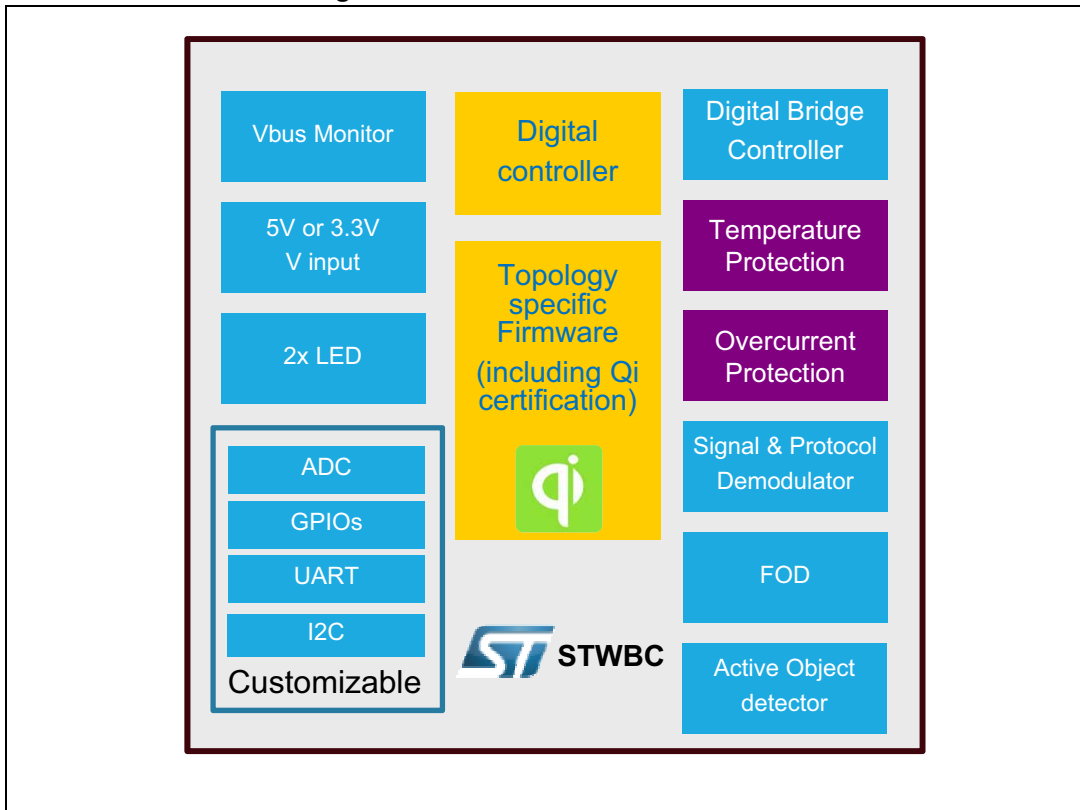

2 Introduction to wireless battery charging systems

Wireless battery charging systems replace the traditional power supply cable by means of electromagnetic induction between a transmitting pad (TX) and a battery powered unit (RX), such as a mobile phone or a battery pack.

The power transmitter unit is responsible for controlling the transmitting coil and generating the correct amount of power requested by the receiver unit. The receiver unit continuously feeds back to the transmitter the correct power level requested by modulating the transmitter carrier by means of a controlled resistive or capacitive insertion. Generating the correct amount of power guarantees the highest level of end-to-end efficiency due to reduced energy waste. Also, it helps maintaining a lower operational temperature.

The digital feedback is also used to detect foreign objects, i.e.: metal incorrectly exposed to the coils. By stopping the application as soon as a foreign object is detected the risk of damage is reduced.

Digital wireless battery transmitters can adapt the amount of energy transferred by the coil by modulating the frequency, duty cycles or coil input voltage.

Figure 2. System view of a wireless charging system

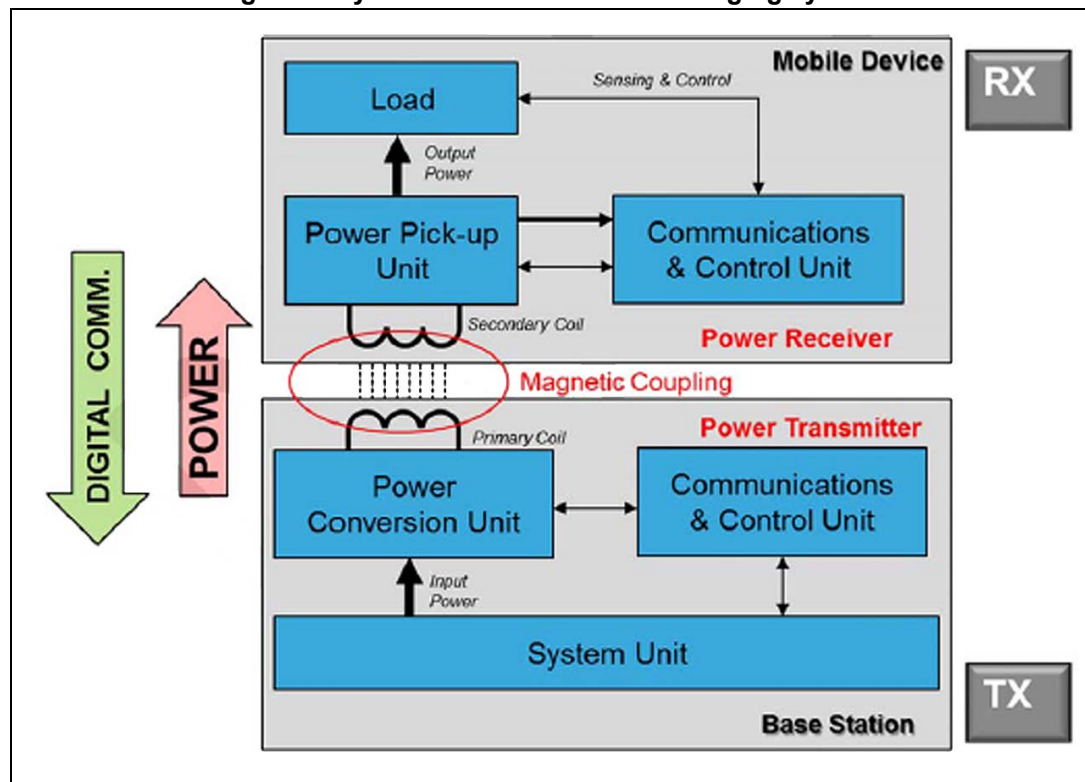

Thanks to the internal STWBC 96 MHz clock, support for half-bridge and full bridge topologies and protocol detection units, the STWBC can drive the power emitted by a transmitting coil. The STWBC firmware sits on the top of the hardware to monitor and control the correct wireless charging operations.

3 Certified Qi A11 solution

The STWBC has been certified for Qi A11, thanks to the STEVAL-ISB027V1 reference design. The certification is based on the Qi standard version 1.1.2 and supports FOD (“Foreign Object Detection”).

The STEVAL-ISB027V1 reference design provides a complete kit which includes the STWBC IC, firmware, layout, graphical interfaces and tools. The layout is based on a cost-effective 2-layer PCB.

Firmware

The STWBC firmware is available in two separate software packages:

- Turn-key: the firmware is distributed as a binary file.
- API customizable: the firmware is designed as a library and external functions as well as peripherals can be added by means of APIs.

The software APIs allow a great freedom of application customization. The STWBC and the API library can be accessed by programming the internal controller via standard programming tools such as the IAR™ Workbench® Studio.

Every STWBC wireless charging architecture is a reference design supported by firmware, evaluation boards, application notes and PCB layouts notes.

4 Pinout and pin description

The STWBC is a multifunction device that can support several wireless charging architectures. The pinout is therefore application specific. [Section 4.1](#) shows the pinout used by the STWBC when the Qi A11 configuration is used.

4.1 Pinout for STWBC in Qi A11 configuration

Figure 3. STWBC pinout view

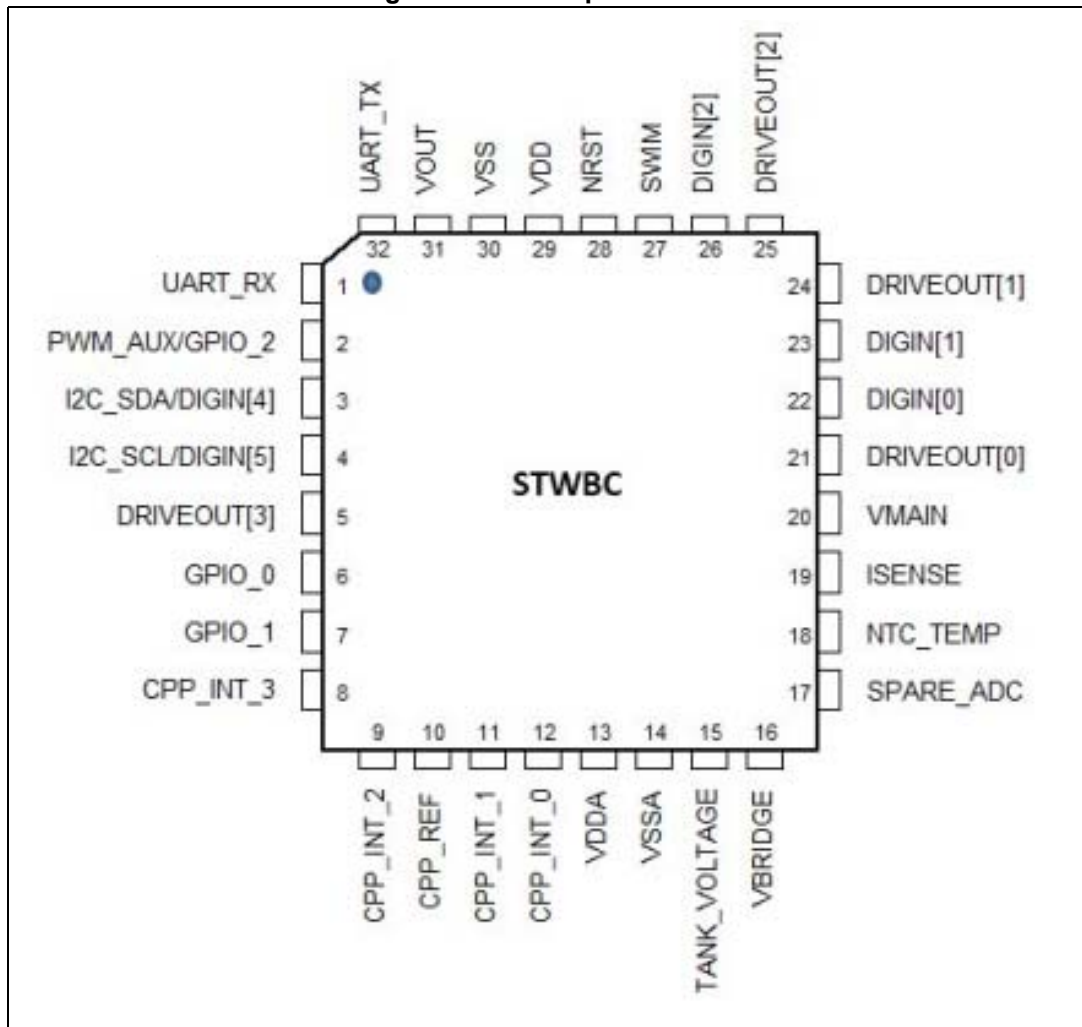

4.2 Pin description

Table 1. Pinout description

Pin no.	Pin name	Pin type	API firmware description	Bin firmware description
1	UART_RX ⁽¹⁾	DI	UART RX link	UART RX link
2	PWM_AUX/GPIO_2 ⁽¹⁾	DO	PWM output or GPO	Not used, must not be connected to any potential
3	I2C_SDA/DIGIN [4] ⁽¹⁾		I2C_SDA / digital input 4	inactive (internal pull-up)
4	I2C_SCL/DIGIN [5] ⁽¹⁾		I2C_SCL / digital input 5	inactive (internal pull-up)
5	DRIVEOUT [3]	DO	Output driver for low-side branch right	Output driver for low-side branch right
6	GPIO_0 ⁽¹⁾	DO	Digital output for the green light indicator / general purpose I/O	Digital output for the green light indicator
7	GPIO_1 ⁽¹⁾	DO	Digital output for the red light indicator / general purpose I/O	Digital output for the red light indicator
8	CPP_INT_3	AI	Symbol detector	Symbol detector
9	CPP_INT_2	AI	Vmain monitor	Vmain monitor
10	CPP_REF	AI	External reference for CPP_INT_3 (if not used, must be tied to GND)	External reference for CPP_INT_3 (if not used, must be tied to GND)
11	CPP_INT_1	AI	Symbol detector	Symbol detector
12	CPP_INT_0	AI	Symbol detector	Symbol detector
13	VDDA	PS	Analog power supply	Analog power supply
14	VSSA	PS	Analog ground	Analog ground
15	TANK_VOLTAGE	AI	LC tank voltage probe	LC tank voltage probe
16	VBRIDGE		Inactive (to be tied to GND)	Inactive (to be tied to GND)
17	SPARE_ADC ⁽¹⁾		Spare analog input (to be tied to GND if not used)	Spare analog input (to be tied to GND)
18	NTC_TEMP	AI	NTC temperature measurement.	NTC temperature measurement.
19	ISENSE	AI	LC tank current measurement	LC tank current measurement
20	VMAIN	AI	Vmain monitor	Vmain monitor
21	DRIVEOUT [0]	DO	Output driver for low-side branch left	Output driver for low-side branch left
22	DIGIN [0] ⁽¹⁾		Digital input 0	inactive (internal pull-up)
23	DIGIN [1] ⁽¹⁾		Digital input 1	inactive (internal pull-up)
24	DRIVEOUT [1]	DO	Output driver for high-side branch left	Output driver for high-side branch left
25	DRIVEOUT [2]	DO	Output driver for high-side branch right	Output driver for high-side branch right
26	DIGIN [2] ⁽¹⁾		Digital input 2	inactive (internal pull-up)
27	SWIM	DIO	Debug interface	Debug interface

Table 1. Pinout description (continued)

Pin no.	Pin name	Pin type	API firmware description	Bin firmware description
28	NRST	DI	Reset	Reset
29	VDD	PS	Digital and I/O power supply	Digital and I/O power supply
30	VSS	PS	Digital and I/O ground	Digital and I/O ground
31	VOUT	Supply	Internal LDO output	Internal LDO output
32	UART_TX ⁽¹⁾	DO	UART TX link	UART TX link

1. API configurable.

5 Electrical characteristics

5.1 Parameter conditions

Unless otherwise specified, all voltages are referred to V_{SS} . V_{DDA} and V_{DD} must be connected to the same voltage value. V_{SS} and V_{SSA} must be connected together with the shortest wire loop.

5.1.1 Minimum and maximum values

Unless otherwise specified, the minimum and maximum values are guaranteed in the worst conditions of ambient temperature, supply voltage and frequencies by tests in production on 100% of the devices with an ambient temperature at $T_A = 25\text{ °C}$ and $T_A = T_A \text{ max.}$ (given by the selected temperature range).

Data based on characterization results, design simulation and/or technology characteristics are indicated in [Table 2](#), [Table 3](#) and from [Table 5 on page 17](#) to [Table 17 on page 29](#) footnotes and are not tested in production.

5.1.2 Typical values

Unless otherwise specified, typical data are based on $T_A = 25\text{ °C}$, V_{DD} and $V_{DDA} = 3.3\text{ V}$. They are given only as design guidelines and are not tested. Typical ADC accuracy values are determined by characterization of a batch of samples from a standard diffusion lot over the full temperature range.

5.1.3 Typical curves

Unless otherwise specified, all typical curves are given as design guidelines only and are not tested.

5.1.4 Typical current consumption

For typical current consumption measurements, V_{DD} and V_{DDA} are connected together as shown in [Figure 4](#).

Figure 4. Supply current measurement conditions

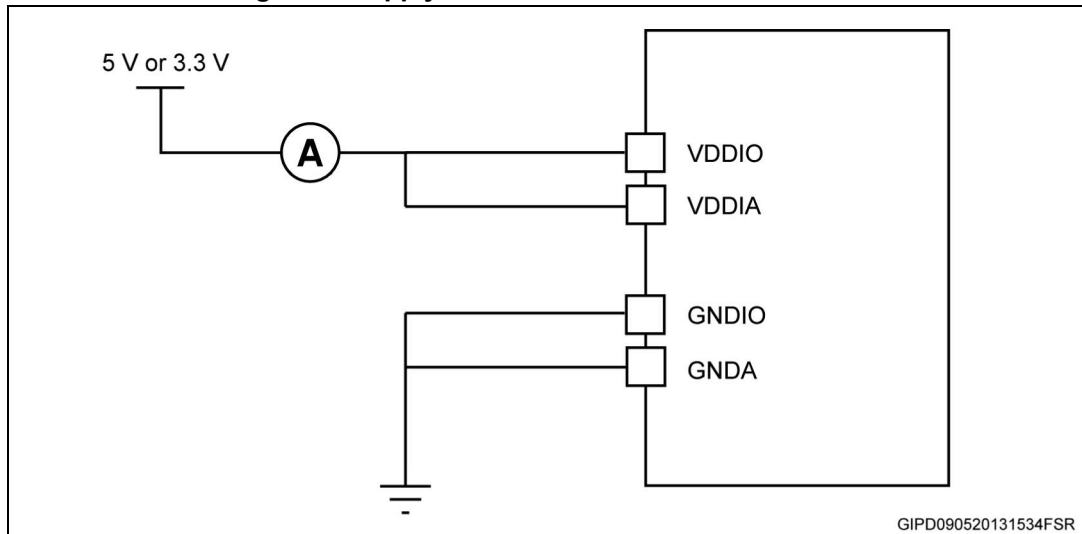

GIPD090520131534FSR

5.1.5 Loading capacitors

The loading conditions used for the pin parameter measurement are shown in [Figure 5](#):

Figure 5. Pin loading conditions

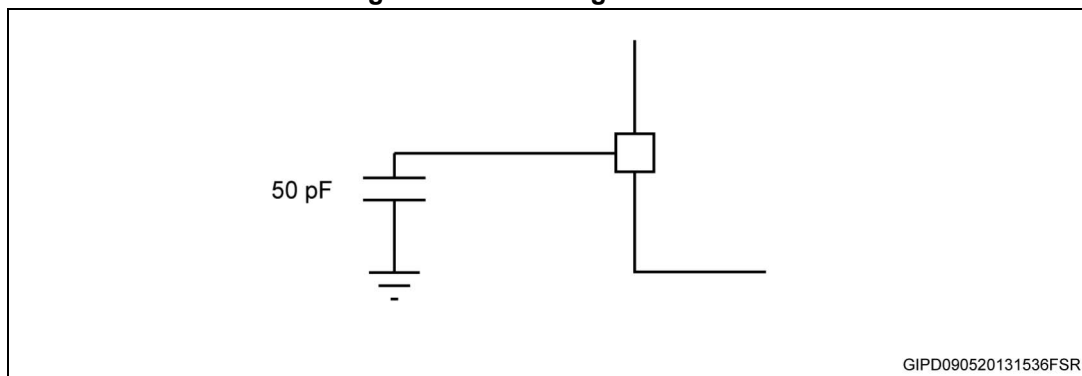

GIPD090520131536FSR

5.1.6 Pin output voltage

The input voltage measurement on a pin is described in [Figure 6](#).

Figure 6. Pin input voltage

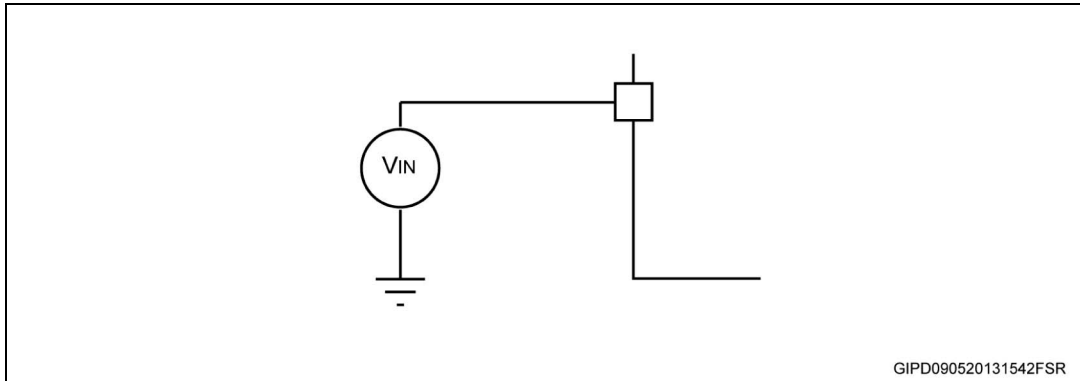

5.2 Absolute maximum ratings

Stresses above those listed as 'absolute maximum ratings' may cause permanent damage to the device. This is a stress rating only and functional operation of the device under these conditions is not implied. Exposure to maximum rating conditions for extended periods may affect the device reliability.

Table 2. Voltage characteristics

Symbol	Ratings	Min.	Max.	Unit
$V_{DDX} - V_{SSX}$	Supply voltage ⁽¹⁾	-0.3	6.5	V
V_{IN}	Input voltage on any other pin ⁽²⁾	VSS -0.3	VDD +0.3	
$V_{DD} - V_{DDA}$	Variation between different power pins		50	mV
$V_{SS} - V_{SSA}$	Variation between all the different ground pins ⁽³⁾		50	
V_{ESD}	Electrostatic discharge voltage	Refer to absolute maximum ratings (electrical sensitivity) in Section 5.4.1 on page 31 .		

1. All power V_{DDX} (V_{DD} , V_{DDA}) and ground V_{SSX} (V_{SS} , V_{SSA}) pins must always be connected to the external power supply.
2. $I_{INJ(PIN)}$ must never be exceeded. This is implicitly insured if V_{IN} maximum is respected. If V_{IN} maximum cannot be respected, the injection current must be limited externally to the $I_{INJ(PIN)}$ value. A positive injection is induced by $V_{IN} > V_{DD}$ while a negative injection is induced by $V_{IN} < V_{SS}$.
3. V_{SS} and V_{SSA} signals must be interconnected together with a short wire loop.

Table 3. Current characteristics

Symbol	Ratings	Max. ⁽¹⁾	Unit
I_{VDDX}	Total current into VDDX power lines ⁽²⁾	100	mA
I_{VSSX}	Total current out of VSSX power lines ⁽²⁾	100	
I_{IO}	Output current sunk by any I/Os and control pin	Ref. to Table 11 on page 21	
	Output current source by any I/Os and control pin		
$I_{INJ(PIN)}^{(3), (4)}$	Injected current on any pin	±4	
$I_{INJ(TOT)}^{(3), (4), (5)}$	Sum of injected currents	±20	

1. Data based on characterization results, not tested in production
2. All power V_{DDX} (V_{DD} , V_{DDA}) and ground V_{SSX} (V_{SS} , V_{SSA}) pins must always be connected to the external power supply.
3. $I_{INJ(PIN)}$ must never be exceeded. This is implicitly insured if V_{IN} maximum is respected. If V_{IN} maximum cannot be respected, the injection current must be limited externally to the $I_{INJ(PIN)}$ value. A positive injection is induced by $V_{IN} > V_{DD}$ while a negative injection is induced by $V_{IN} < V_{SS}$.
4. Negative injection disturbs the analog performance of the device.
5. When several inputs are submitted to a current injection, the maximum $\Sigma I_{INJ(PIN)}$ is the absolute sum of the positive and negative injected currents (instantaneous values). These results are based on characterization with $\Sigma I_{INJ(PIN)}$ maximum current injection on four I/O port pins of the device.

Table 4. Thermal characteristics

Symbol	Ratings	Max.	Unit
T_{STG}	Storage temperature range	-65 to 150	°C
T_J	Maximum junction temperature	150	

5.3 Operating conditions

The device must be used in operating conditions that respect the parameters in [Table 5](#). In addition, a full account must be taken for all physical capacitor characteristics and tolerances.

Table 5. General operating conditions

Symbol	Parameter	Conditions	Min.	Typ.	Max.	Unit
V_{DD1}, V_{DDA1}	Operating voltages		3 ⁽¹⁾		5.5 ⁽¹⁾	V
V_{DD}, V_{DDA}	Nominal operating voltages		3.3 ⁽¹⁾		5 ⁽¹⁾	
V_{OUT}	Core digital power supply			1.8 ⁽²⁾		
	C_{VOUT} : capacitance of external capacitor ⁽³⁾	at 1 MHz	470		3300	nF
	ESR of external capacitor ⁽²⁾		0.05		0.2	Ω
	ESL of external capacitor ⁽²⁾					
Θ_{JA} ⁽⁴⁾	FR4 multilayer PCB	VFQFPN32		26		$^{\circ}\text{C}/\text{W}$
T_A	Ambient temperature	$P_d = 100 \text{ mW}$	-40		105	$^{\circ}\text{C}$

1. The external power supply can be within range from 3 V up to 5.5 V.
2. Internal core power supply voltage.
3. Care should be taken when the capacitor is selected due to its tolerance, its dependency on temperature, DC bias and frequency.
4. To calculate $P_{Dmax}(T_A)$, use the formula $P_{Dmax} = (T_{Jmax} - T_A)/\Theta_{JA}$.

Table 6. Operating conditions at power-up/power-down

Symbol	Parameter	Conditions	Min. ⁽¹⁾	Typ.	Max. ⁽²⁾	Unit
t_{TEMP}	Reset release delay	V_{DD} rising		3		ms
V_{IT+}	Power-on reset threshold		2.65	2.8	2.98	V
V_{IT-}	Brownout reset threshold		2.58	2.73	2.88	

1. Guaranteed by design, not tested in production.
2. Power supply ramp must be monotone.

5.3.1 VOUT external capacitor

The stabilization of the main regulator is achieved by connecting an external capacitor $C_{VOUT}^{(b)}$ to the VOUT pin. The C_{VOUT} is specified in [Section 5.3: Operating conditions](#). Care should be taken to limit the series inductance to less than 15 nH.

Figure 7. External capacitor C_{VOUT}

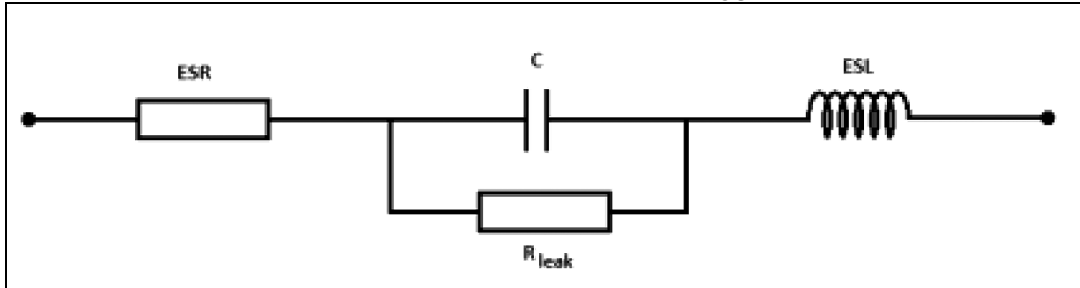

5.3.2 Internal clock sources and timing characteristics

HSI RC oscillator

The HSI RC oscillator parameters are specified under general operating conditions for V_{DD} and T_A .

Table 7. HSI RC oscillator

Symbol	Parameter	Conditions	Min. ⁽¹⁾	Typ.	Max. ⁽¹⁾	Unit
f_{HSI}	Frequency			16		MHz
ACC_{HSI}	Accuracy of HSI oscillator (factory calibrated) ^{(1), (2)}	$V_{DD} = 3.3\text{ V}$ $T_A = 25\text{ °C}$	-1%		+1%	%
		$V_{DD} = 3.3\text{ V}$ $-40\text{ °C} \leq T_A \leq 105\text{ °C}$	-4%		+4%	
		$V_{DD} = 5\text{ V}$ $-40\text{ °C} \leq T_A \leq 105\text{ °C}$	-4%		+4%	
$t_{SU(HSI)}$	HSI oscillator wakeup time including calibration			1		μs

1. Data based on characterization results, not tested in production.
2. Variation referred to f_{HSI} nominal value.

b. ESR is the equivalent series resistance and ESL is the equivalent inductance.

LSI RC oscillator

The LSI RC oscillator parameters are specified under general operating conditions for V_{DD} and T_A .

Table 8. LSI RC oscillator

Symbol	Parameter	Conditions	Min. ⁽¹⁾	Typ.	Max. ⁽¹⁾	Unit
f_{LSI}	Frequency			153.6		kHz
ACC_{LSI}	Accuracy of LSI oscillator	$3.3\text{ V} \leq V_{DD} \leq 5\text{ V}$ $-40\text{ °C} \leq T_A \leq 105\text{ °C}$	-10%		10%	%
$t_{SU(LSI)}$	LSI oscillator wakeup time			7		μs

1. Guaranteed by design, not tested in production.

PLL internal source clock

Table 9. PLL internal source clock

Symbol	Parameter	Conditions	Min	Typ.	Max. ⁽¹⁾	Unit
f_{IN}	Input frequency ⁽²⁾	$3.3\text{ V} \leq V_{DD} \leq 5\text{ V}$ $-40\text{ °C} \leq T_A \leq 105\text{ °C}$		16		MHz
f_{OUT}	Output frequency			96		
t_{lock}	PLL lock time				200	

1. Data based on characterization results, not tested in production.

2. PLL maximum input frequency 16 MHz.

5.3.3 Memory characteristics

Flash program and memory/data E²PROM memory

General conditions: T_A = -40 °C to 105 °C.

Table 10. Flash program memory/data E²PROM memory

Symbol	Parameter	Conditions	Min. ⁽¹⁾	Typ. ⁽¹⁾	Max. ⁽¹⁾	Unit
t _{PROG}	Standard programming time (including erase) for byte/word/block (1 byte/4 bytes/128 bytes)			6	6.6	ms
	Fast programming time for 1 block (128 bytes)			3	3.3	
t _{ERASE}	Erase time for 1 block (128 bytes)			3	3.3	ms
N _{WE}	Erase/write cycles ⁽²⁾ (program memory)	T _A = 25 °C	10 K			Cycles
	Erase/write cycles ⁽²⁾ (data memory)	T _A = 85 °C	100 K			
		T _A = 105 °C	35 K			
t _{RET}	Data retention (program memory) after 10 K erase/write cycles at T _A = 25 °C	T _{RET} = 85 °C	15			Years
	Data retention (program memory) after 10 K erase/write cycles at T _A = 25 °C	T _{RET} = 105 °C	11			
	Data retention (data memory) after 100 K erase/write cycles at T _A = 85 °C	T _{RET} = 85 °C	15			
	Data retention (data memory) after 35 K erase/write cycles at T _A = 105 °C	T _{RET} = 105 °C	6			
I _{DDPRG}	Supply current during program and erase cycles	-40 °C ≤ T _A ≤ 105 °C		2		mA

1. Data based on characterization results, not tested in production.
2. The physical granularity of the memory is 4 bytes, so cycling is performed on 4 bytes even when a write/erase operation addresses a single byte.

5.3.4 I/O port pin characteristics

The I/O port pin parameters are specified under general operating conditions for V_{DD} and T_A unless otherwise specified. Unused input pins should not be left floating.

Table 11. Voltage DC characteristics

Symbol	Description	Min. ⁽¹⁾	Typ.	Max. ⁽¹⁾	Unit
V_{IL}	Input low voltage	-0.3		$0.3 * V_{DD}$	V
V_{IH}	Input high voltage ⁽²⁾	$0.7 * V_{DD}$		V_{DD}	
V_{OL1}	Output low voltage at 3.3 V ⁽³⁾			$0.4^{(4)}$	
V_{OL2}	Output low voltage at 5 V ⁽³⁾			0.5	
V_{OL3}	Output low voltage high sink at 3.3 V / 5 V ^{(2), (5), (6)}		$0.6^{(4)}$		
V_{OH1}	Output high voltage at 3.3 V ⁽³⁾	$V_{DD} - 0.4^{(4)}$			
V_{OH2}	Output high voltage at 5 V ⁽³⁾	$V_{DD} - 0.5$			
V_{OH3}	Output high voltage high sink at 3.3 V / 5 V ^{(2), (5), (6)}	$V_{DD} - 0.6^{(4)}$			
H_{VS}	Hysteresis input voltage ⁽⁷⁾	$0.1 * V_{DD}$			
R_{PU}	Pull-up resistor	30	45	60	k Ω

1. Data based on characterization result, not tested in production.
2. All signals are not 5 V tolerant (input signals can't be exceeded V_{DDX} ($V_{DDX} = V_{DD}, V_{DDA}$)).
3. Parameter applicable to signals: GPIO_[0:2], DRIVEOUT[0:3], PWM_AUX.
4. Electrical threshold voltage not yet characterized at -40 °C.
5. Parameter applicable to signal: SWIM.
6. Parameter applicable to signal: DIGIN [0].
7. Applicable to any digital inputs.

Table 12. Current DC characteristics

Symbol	Description	Min.	Typ.	Max. ⁽¹⁾	Unit
I _{OL1}	Standard output low level current at 3.3 V and V _{OL1} ⁽²⁾			1.5	mA
I _{OL2}	Standard output low level current at 5 V and V _{OL2} ⁽²⁾			3	
I _{OLhs1}	High sink output low level current at 3.3 V and V _{OL3} ^{(3),(4)}			5	
I _{OLhs2}	High sink output low level current at 5 V and V _{OL} ^{(3),(4)}			7.75	
I _{OH1}	Standard output high level current at 3.3 V and V _{OH1} ⁽²⁾			1.5	
I _{OH2}	Standard output high level current at 5 V and V _{OLH2} ⁽²⁾			3	
I _{OHhs1}	High sink output low level current at 3.3 V and V _{OH3} ^{(3),(4)}			5	
I _{OHhs2}	High sink output low level current at 5 V and V _{OH3} ^{(3),(4)}			7.75	
I _{LKg}	Input leakage current digital - analog V _{SS} ≤ V _{IN} ≤ V _{DD} ⁽⁵⁾			± 1	µA
I _{_Inj}	Injection current ^{(6), (7)}			±4	mA
ΣI _{_Inj}	Total injection current (sum of all I/O and control pins) ⁽⁶⁾			± 20	

1. Data based on characterization result, not tested in production.
2. Parameter applicable to signals: GPIO_[0:2], DRIVEOUT[0:3], PWM_AUX.
3. Parameter applicable to signal: SWIM.
4. Parameter applicable to signal: DIGIN [0].
5. Applicable to any digital inputs.
6. Maximum value must never be exceeded.
7. Negative injection current on the ADCIN [7:0] signals (product depending) => SPARE_ADC signals have to avoid since impact the ADC conversion accuracy.

5.3.5 Typical output level curves

This section shows the typical output voltage level curves measured on a single output pin for the two-pad family present in the STWBC device.

Standard pad

This pad is associated to the following signals: DIGIN [0:1], SWIM and GPIO_[0:2] when available.

Figure 8. V_{OH} standard pad at 3.3 V

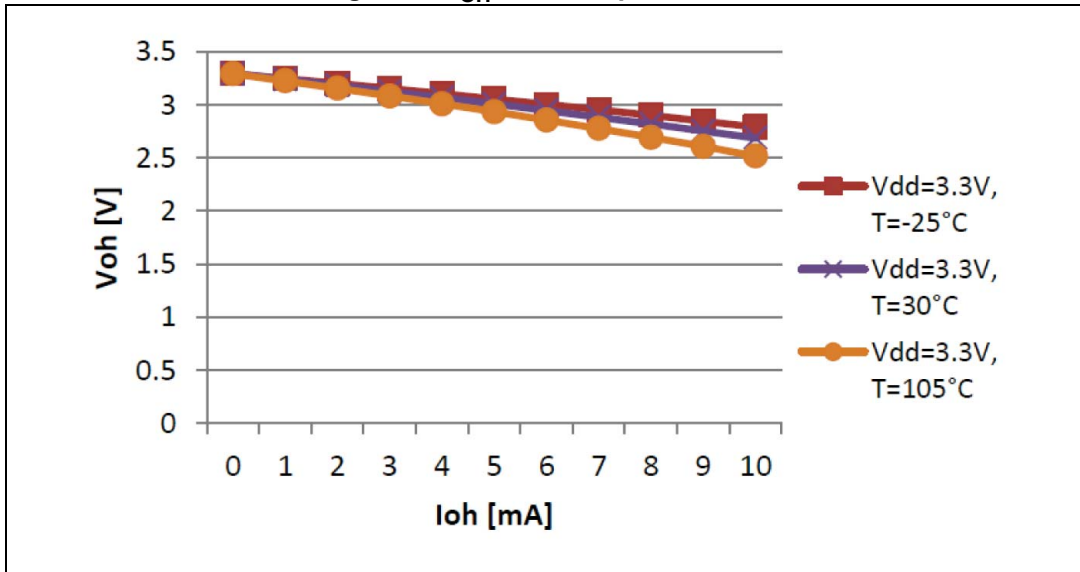

Figure 9. V_{OL} standard pad at 3.3 V

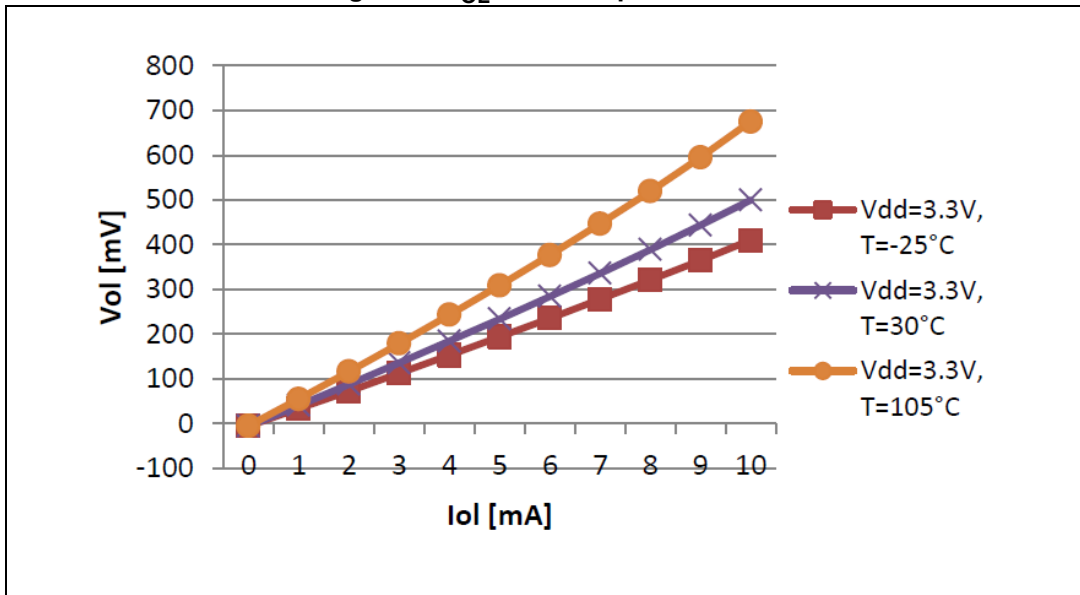

Figure 10. V_{OH} standard pad at 5 V

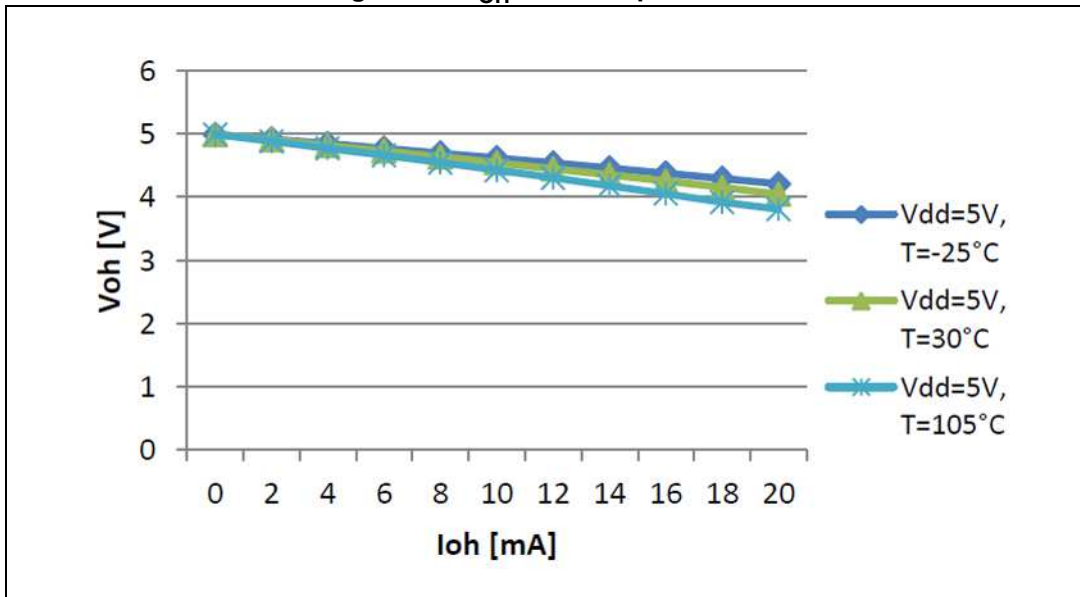
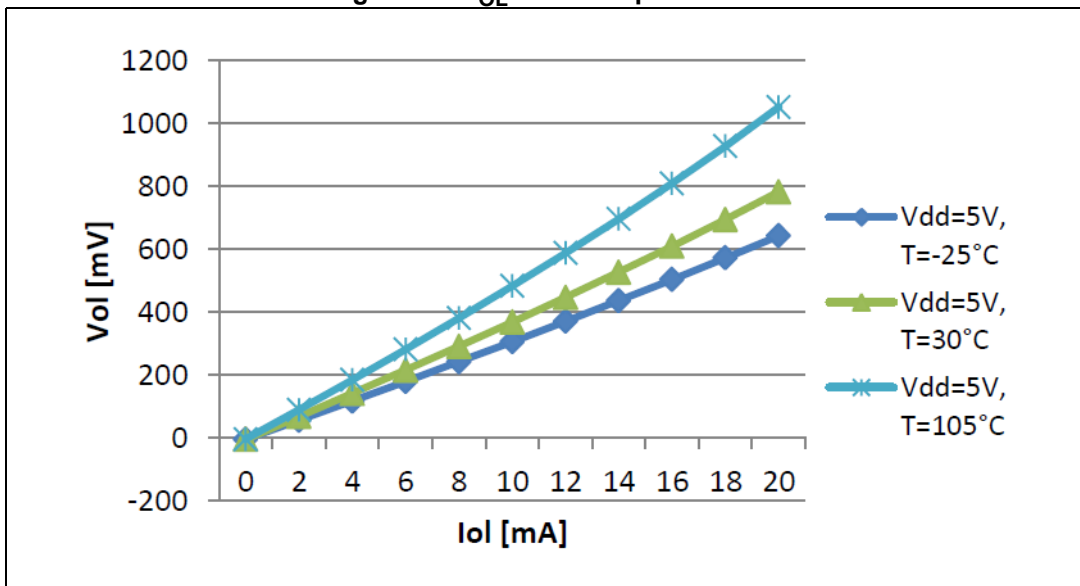

Figure 11. V_{OL} standard pad at 5 V



5.3.6 Fast pad

This pad is associated to the DRIVEOUT[0:3], PWM_AUX signals if the external pin is available.

Figure 12. V_{OH} fast pad at 3.3 V

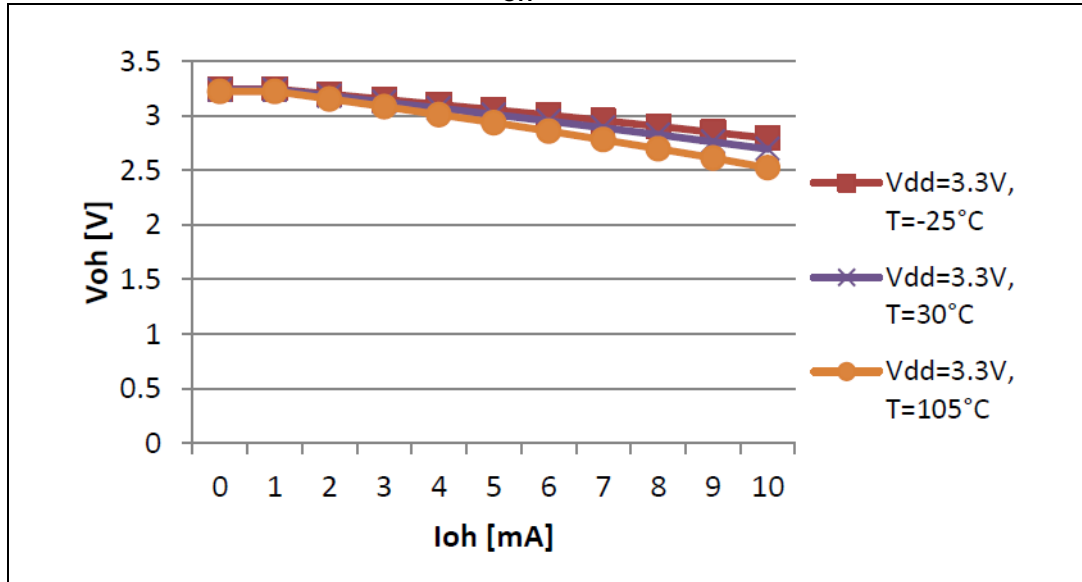

Figure 13. V_{OL} fast pad at 3.3 V

