



Chipsmall Limited consists of a professional team with an average of over 10 year of expertise in the distribution of electronic components. Based in Hongkong, we have already established firm and mutual-benefit business relationships with customers from,Europe,America and south Asia,supplying obsolete and hard-to-find components to meet their specific needs.

With the principle of “Quality Parts,Customers Priority,Honest Operation,and Considerate Service”,our business mainly focus on the distribution of electronic components. Line cards we deal with include Microchip,ALPS,ROHM,Xilinx,Pulse,ON,Everlight and Freescale. Main products comprise IC,Modules,Potentiometer,IC Socket,Relay,Connector.Our parts cover such applications as commercial,industrial, and automotives areas.

We are looking forward to setting up business relationship with you and hope to provide you with the best service and solution. Let us make a better world for our industry!



## Contact us

Tel: +86-755-8981 8866 Fax: +86-755-8427 6832

Email & Skype: info@chipsmall.com Web: www.chipsmall.com

Address: A1208, Overseas Decoration Building, #122 Zhenhua RD., Futian, Shenzhen, China



## High voltage fast-switching NPN power transistor

### Features

- High voltage capability
- Low spread of dynamic parameters
- Very high switching speed

### Applications

- Switching mode power supplies

### Description

The device is manufactured using high voltage Multi Epitaxial Planar technology for high switching speeds and high voltage capability.

It uses a Hollow Emitter structure to enhance switching speeds.

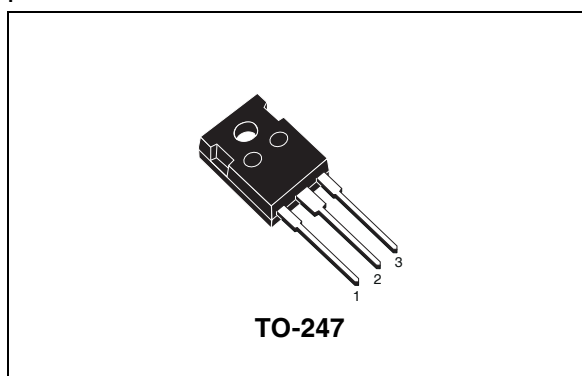

**Figure 1. Internal schematic diagram**

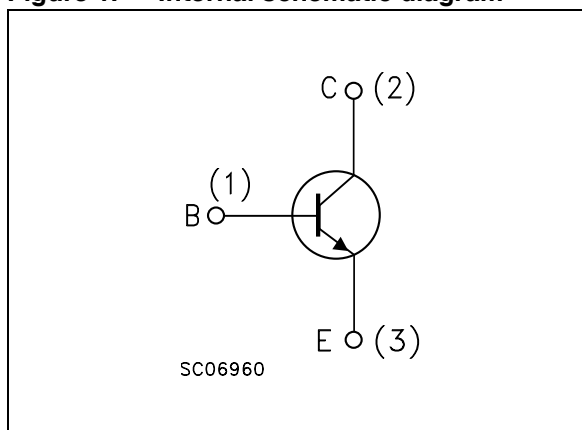

**Table 1. Device summary**

Order code	Marking	Package	Packaging
STWH13009	WH13009	TO-247	Tube

# 1 Absolute maximum ratings

**Table 2. Absolute maximum ratings**

Symbol	Parameter	Value	Unit
$V_{CEV}$	Collector-emitter voltage ( $V_{BE} = -1.5V$ )	700	V
$V_{CEO}$	Collector-emitter voltage ( $I_B = 0$ )	400	V
$V_{EBO}$	Emitter-base voltage ( $I_C = 0$ )	12	V
$I_C$	Collector current	12	A
$I_{CM}$	Collector peak current ( $t_p < ms$ )	24	A
$I_B$	Base current	6	A
$I_{BM}$	Base peak current ( $t_p < ms$ )	12	A
$P_{TOT}$	Total dissipation at $T_{case} = 25^\circ C$	125	W
$T_{stg}$	Storage temperature	-65 to 150	$^\circ C$
$T_J$	Max. operating junction temperature	150	$^\circ C$

**Table 3. Thermal data**

Symbol	Parameters	Value	Unit
$R_{thj-case}$	Thermal resistance junction-case max	1	$^\circ C/W$

## 2 Electrical characteristics

( $T_{\text{case}} = 25^{\circ}\text{C}$ ; unless otherwise specified)

**Table 4. Electrical characteristics**

Symbol	Parameter	Test conditions	Min.	Typ.	Max.	Unit
$I_{\text{CEV}}$	Collector cut-off current ( $V_{\text{BE}} = -1.5\text{V}$ )	$V_{\text{CE}} = 700\text{ V}$			10	$\mu\text{A}$
		$V_{\text{CE}} = 700\text{ V}$ $T_{\text{C}} = 100^{\circ}\text{C}$			500	$\mu\text{A}$
$I_{\text{EBO}}$	Emitter cut-off current ( $I_{\text{C}} = 0$ )	$V_{\text{EB}} = 10\text{ V}$			10	$\mu\text{A}$
$V_{\text{CEO(sus)}}^{(1)}$	Collector-emitter sustaining voltage ( $I_{\text{B}} = 0$ )	$I_{\text{C}} = 10\text{ mA}$	400			V
$V_{\text{CE(sat)}}^{(1)}$	Collector-emitter saturation voltage	$I_{\text{C}} = 4\text{ A}$ $I_{\text{B}} = 0.8\text{ A}$		0.2	0.5	V
		$I_{\text{C}} = 5\text{ A}$ $I_{\text{B}} = 1\text{ A}$		0.25	0.6	V
		$I_{\text{C}} = 8\text{ A}$ $I_{\text{B}} = 1.6\text{ A}$		0.35	1	V
		$I_{\text{C}} = 12\text{ A}$ $I_{\text{B}} = 2.4\text{ A}$		0.6	2	V
$V_{\text{BE(sat)}}^{(1)}$	Base-emitter saturation voltage	$I_{\text{C}} = 5\text{ A}$ $I_{\text{B}} = 1\text{ A}$			1.2	V
		$I_{\text{C}} = 8\text{ A}$ $I_{\text{B}} = 1.6\text{ A}$			1.6	V
$h_{\text{FE}}^{(1)}$	DC current gain	$I_{\text{C}} = 5\text{ A}$ $V_{\text{CE}} = 5\text{ V}$	18		30	
		$I_{\text{C}} = 8\text{ A}$ $V_{\text{CE}} = 5\text{ V}$	11		23	
$t_{\text{s}}$ $t_{\text{f}}$	Inductive load	$V_{\text{CC}} = 250\text{ V}$ $I_{\text{C}} = 5\text{ A}$				
	Storage time	$I_{\text{B1}} = 1\text{ A}$ $I_{\text{B2}} = -2\text{ A}$		1.7	2.5	$\mu\text{s}$
	Fall time	$L = 200\text{ }\mu\text{H}$		100	140	ns

1. Pulsed duration = 300 ms, duty cycle  $\geq 1.5\%$ .

## 2.1 Electrical characteristic (curves)

Figure 2. Safe operating area

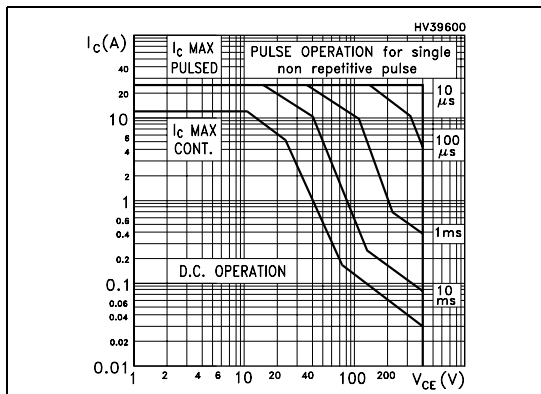

Figure 3. Derating curve

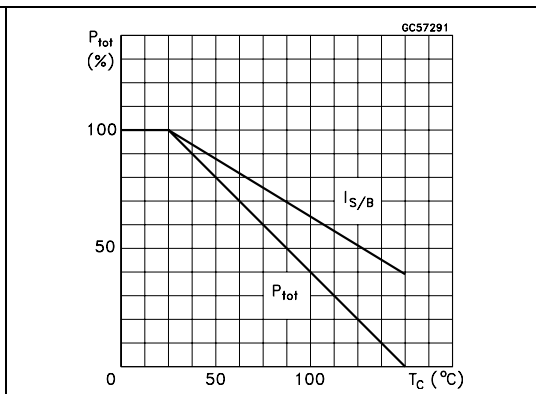

Figure 4. DC current gain

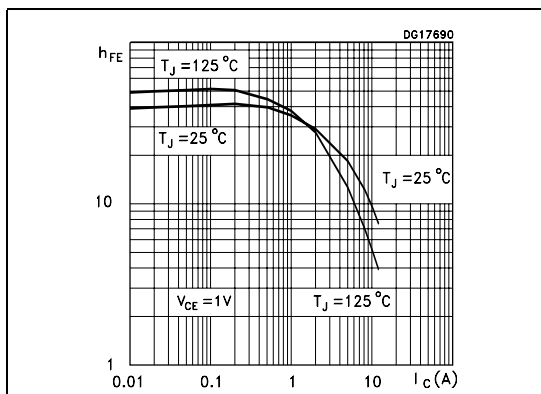

Figure 5. DC current gain

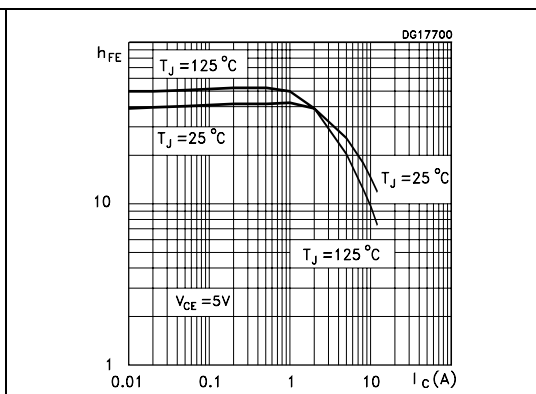

Figure 6. Collector-emitter saturation voltage

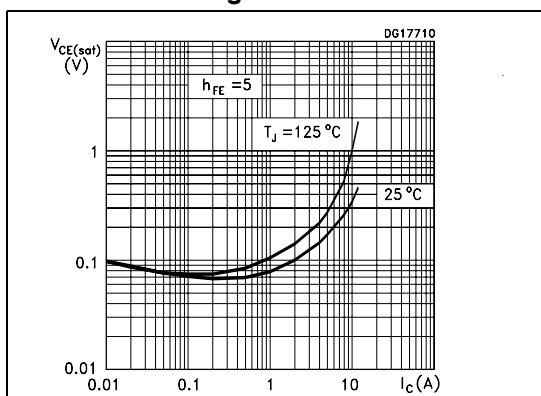
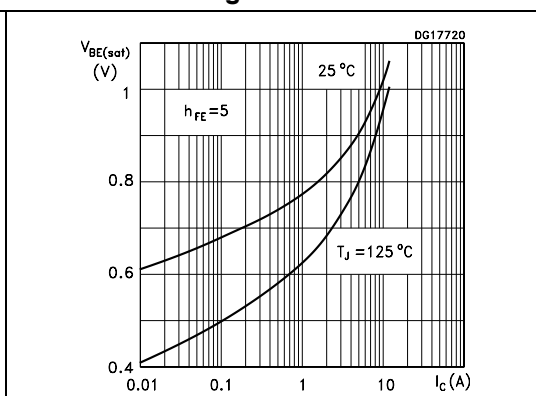
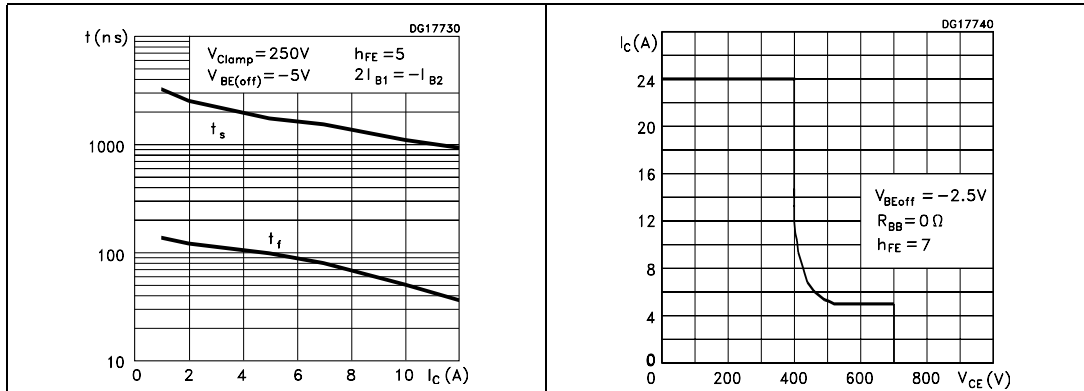

Figure 7. Base-emitter saturation voltage

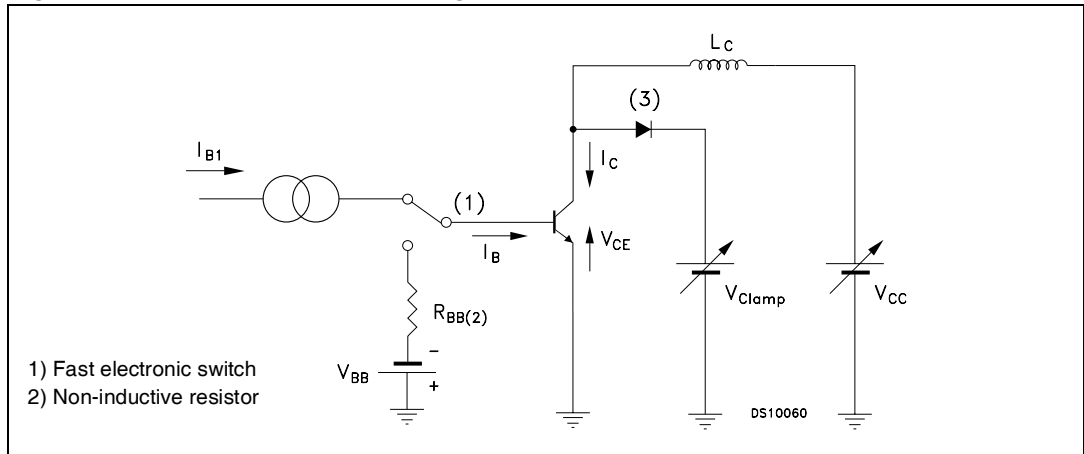

**Figure 8. Inductive load switching time** **Figure 9. Reverse biased safe operating area**



## 2.2 Test circuit

**Figure 10. Inductive load switching test circuit**



### 3 Package mechanical data

In order to meet environmental requirements, ST offers these devices in ECOPACK® packages. These packages have a Lead-free second level interconnect . The category of second level interconnect is marked on the package and on the inner box label, in compliance with JEDEC Standard JESD97. The maximum ratings related to soldering conditions are also marked on the inner box label. ECOPACK is an ST trademark. ECOPACK specifications are available at: [www.st.com](http://www.st.com)

## TO-247 Mechanical data

Dim.	mm.		
	Min.	Typ	Max.
A	4.85		5.15
A1	2.20		2.60
b	1.0		1.40
b1	2.0		2.40
b2	3.0		3.40
c	0.40		0.80
D	19.85		20.15
E	15.45		15.75
e		5.45	
L	14.20		14.80
L1	3.70		4.30
L2		18.50	
øP	3.55		3.65
øR	4.50		5.50
S		5.50	

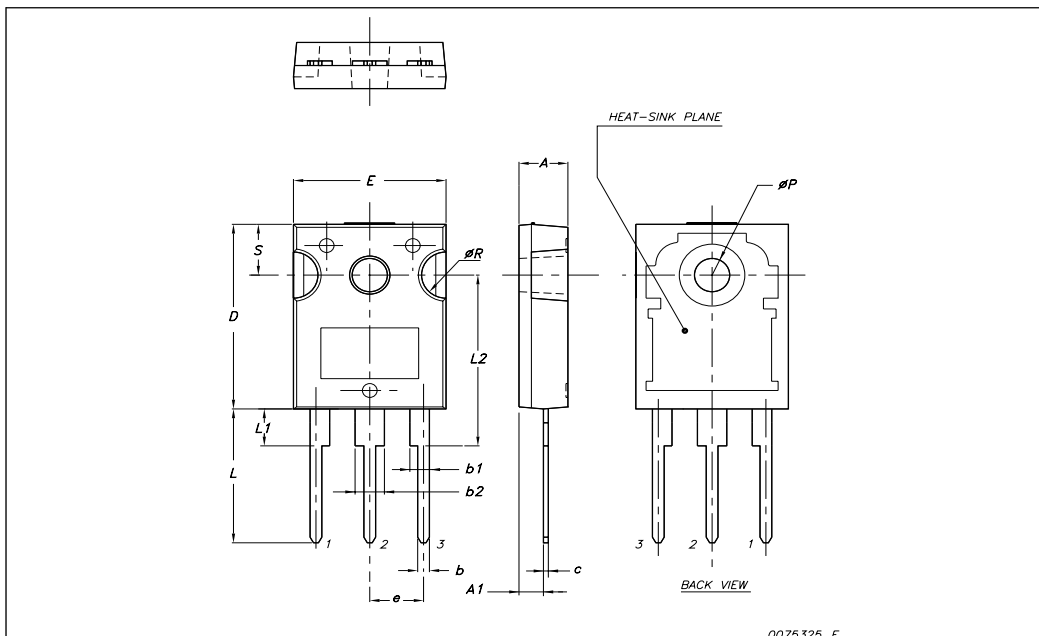

## 4 Revision history

**Table 5. Document revision history**

Date	Revision	Changes
19-Oct-2007	1	Initial Release

**Please Read Carefully:**

Information in this document is provided solely in connection with ST products. STMicroelectronics NV and its subsidiaries ("ST") reserve the right to make changes, corrections, modifications or improvements, to this document, and the products and services described herein at any time, without notice.

All ST products are sold pursuant to ST's terms and conditions of sale.

Purchasers are solely responsible for the choice, selection and use of the ST products and services described herein, and ST assumes no liability whatsoever relating to the choice, selection or use of the ST products and services described herein.

No license, express or implied, by estoppel or otherwise, to any intellectual property rights is granted under this document. If any part of this document refers to any third party products or services it shall not be deemed a license grant by ST for the use of such third party products or services, or any intellectual property contained therein or considered as a warranty covering the use in any manner whatsoever of such third party products or services or any intellectual property contained therein.

**UNLESS OTHERWISE SET FORTH IN ST'S TERMS AND CONDITIONS OF SALE ST DISCLAIMS ANY EXPRESS OR IMPLIED WARRANTY WITH RESPECT TO THE USE AND/OR SALE OF ST PRODUCTS INCLUDING WITHOUT LIMITATION IMPLIED WARRANTIES OF MERCHANTABILITY, FITNESS FOR A PARTICULAR PURPOSE (AND THEIR EQUIVALENTS UNDER THE LAWS OF ANY JURISDICTION), OR INFRINGEMENT OF ANY PATENT, COPYRIGHT OR OTHER INTELLECTUAL PROPERTY RIGHT.**

**UNLESS EXPRESSLY APPROVED IN WRITING BY AN AUTHORIZED ST REPRESENTATIVE, ST PRODUCTS ARE NOT RECOMMENDED, AUTHORIZED OR WARRANTED FOR USE IN MILITARY, AIR CRAFT, SPACE, LIFE SAVING, OR LIFE SUSTAINING APPLICATIONS, NOR IN PRODUCTS OR SYSTEMS WHERE FAILURE OR MALFUNCTION MAY RESULT IN PERSONAL INJURY, DEATH, OR SEVERE PROPERTY OR ENVIRONMENTAL DAMAGE. ST PRODUCTS WHICH ARE NOT SPECIFIED AS "AUTOMOTIVE GRADE" MAY ONLY BE USED IN AUTOMOTIVE APPLICATIONS AT USER'S OWN RISK.**

Resale of ST products with provisions different from the statements and/or technical features set forth in this document shall immediately void any warranty granted by ST for the ST product or service described herein and shall not create or extend in any manner whatsoever, any liability of ST.

ST and the ST logo are trademarks or registered trademarks of ST in various countries.

Information in this document supersedes and replaces all information previously supplied.

The ST logo is a registered trademark of STMicroelectronics. All other names are the property of their respective owners.

© 2007 STMicroelectronics - All rights reserved

STMicroelectronics group of companies

Australia - Belgium - Brazil - Canada - China - Czech Republic - Finland - France - Germany - Hong Kong - India - Israel - Italy - Japan - Malaysia - Malta - Morocco - Singapore - Spain - Sweden - Switzerland - United Kingdom - United States of America

[www.st.com](http://www.st.com)

