



Chipsmall Limited consists of a professional team with an average of over 10 year of expertise in the distribution of electronic components. Based in Hongkong, we have already established firm and mutual-benefit business relationships with customers from,Europe,America and south Asia,supplying obsolete and hard-to-find components to meet their specific needs.

With the principle of "Quality Parts,Customers Priority,Honest Operation,and Considerate Service",our business mainly focus on the distribution of electronic components. Line cards we deal with include Microchip,ALPS,ROHM,Xilinx,Pulse,ON,Everlight and Freescale. Main products comprise IC,Modules,Potentiometer,IC Socket,Relay,Connector.Our parts cover such applications as commercial,industrial, and automotives areas.

We are looking forward to setting up business relationship with you and hope to provide you with the best service and solution. Let us make a better world for our industry!



Contact us

Tel: +86-755-8981 8866 Fax: +86-755-8427 6832

Email & Skype: info@chipsmall.com Web: www.chipsmall.com

Address: A1208, Overseas Decoration Building, #122 Zhenhua RD., Futian, Shenzhen, China



Description

The power distribution system SVS18 optimises the DC 24 V distribution in automation and process control, in the production area of the chemical industry and in power plants. The power distribution system SVS18 DIN rail mounting distributes all voltage potentials supplied by a 24 V power supply (SMPS) onto 6/10 ways F1 to F6/F10 (arranged from right to left). The system offers 2 integral redundancy diodes in each protected load output and selectively protects the connected loads such as controls, transformers, actuators, magnetic yoke sub-assemblies, bus modules etc. by means of the circuit breaker fitted. With a max. total current of 25 A and a typical load current of 3 A per way (max. 6 A in limited continuous duty) the SVS18 provides ease of distribution and sub-distribution in short-circuit-limited DC 24 V applications. All auxiliary contacts (make contacts) of the plugged-in circuit breakers are connected in series and allow group signalling in accordance with the closed-circuit principle. The protected »L+« load outputs with 2 redundancy diodes per way significantly reduce the otherwise standard wiring time. All terminals of the DC 24 V supply, load outputs with 0V return conductor as well as the signalling terminals are screwless spring-loaded terminals.

Suitable for the following E-T-A circuit breaker types:

electronic circuit breaker	ESS20-003-DC24V- max. 6A
electronic circuit breaker	ESS30-S003-DC24V- max. 6A
electronic circuit protector	ESX10-103-DC24V- max. 6A

Features and benefits

- Systematic integration of overcurrent protection, power distribution and signalling on one board
- Power distribution and selective protection of DC 24 V load circuits fed by a single power supply (SVS18-06) or by two separate power supplies (SVS18-10)
- Clear distribution concept, two each redundancy diodes (typically 1.5 A, max. 3 A per diode) connected in parallel integral in each load output
- Terminal block for group signalling (make contacts)
- Profitability through significant reduction of wiring time
- Reduced time and expenses for planning, design and installation
- Ease of maintenance, diagnosis and system extension



Technical data (T_{amb} = 25 °C, U_B = DC 24 V)

Application

Modular power distribution system for short circuit current limited DC 24 V – applications.

Use with switch-mode power supply, e.g. type Quint DC 24 V / 20 A (manufactured by Phoenix Contact)

Supply SVS18-06

Rated voltage:	DC 24 V (18...30 V)
Total current:	max. 25 A, continuously DC 24 V (+) = X21 L1/L1 DC 24 V (-) = X21 L-/L-/L- L1: supply potential for F1 ... F6 L-: 0 V return conductor
Terminals	screwless plug-in terminal block, 5-pole max. cable cross section 0,75...10 mm ²

Supply SVS18-10

Rated voltage:	DC 24 V (18...30 V), 2 supply potentials L1+ and L2+ possible Caution: L1+ and L2+ are bridged when delivered
Total current:	max. 25 A, continuously DC 24 V (+) = X21 L1+/L1+ DC 24 V (+) = X21 L2+/L2+ DC 24 V (-) = X21 L-/L-/L- L1+: supply potential for F1/F3/F5/F7 L2+: supply potential for F2/F4/F6/F8/F9/F10 L-: 0 V return conductor for L1+ and L2+
Terminals	screwless plug-in terminal block, 7-pole max. cable cross section 0.75...10 mm ²

F-positions SVS18-06

	6 slots F1 to F6 for electronic circuit breakers, prepared for types ESS20-003, ESX10-103: placed from right (F1) to left (F6)
Input	F1 ... F6: input connected to 24 V-voltage L1
Output L1+	F1 ... F6: Output via redundancy diodes to X1/L1 ... X6/L6 (terminals 1+ , 2+ each) Please plug jumper SB-11-P1-01-1-1A into free slots (to be ordered separately, see accessories)



Caution:

When using an electronic circuit breaker rated > 3 A, the redundancy diodes have to be connected in parallel. The jumper for connecting the diodes in parallel has to be plugged in.

Technical data ($T_{amb} = 25\text{ °C}$, $U_B = \text{DC } 24\text{ V}$)

F-positions SVS18-10

	10 slots F1 to F10 for electronic circuit breakers, prepared for types ESS20-003, ESS30-S003, ESX10-103: placed from right (F1) to left (F10)
Input	F1, F3, F5, F7: input connected to 24 V-voltage L1+ F2, F4, F6, F8, F9, F10: input connected to 24 V-voltage L2+
Output L1+	F1, F3, F5, F7: Output via redundancy diodes to X1/L1, X3/L1, X5/L1, X7/L1 (terminals 1+, 2+ each)
Output L2+	F2, F4, F6, F8, F9, F10: Output via redundancy diodes to X2/L2, X4/L2, X6/L2, X8/L2, X9/L2, X10/L2 (terminals 1+, 2+ each)
	Please plug jumper SB-11-P1-01-1-1A into free slots (to be ordered separately, see accessories)

Caution:
When using an electronic circuit breaker rated $> 3\text{ A}$, the redundancy diodes have to be connected in parallel. The jumper for connecting the diodes in parallel has to be plugged in.

Load outputs per way

Rated voltage	DC 24 V (18...30 V)
Current	max. 6 A per terminal block (X1...X6/X10) / per slot (F1...F6/F10)
Caution:	max. load current has to be observed typically 3 A per slot / typically 1.5 A per diode (standard redundancy operation) max. 6 A per slot / max. 3 A per diode (for 8 hrs at $T_{amb} 40\text{ °C}$)

Condition as supplied:
load output bridge plugged in, the 2 diodes are connected in parallel
Example: On slot F1, the diodes D1.1 and D1.2 and thus also the outputs (1+, 2+) are connected in parallel on terminals X1/L1.

Number	2 protected load outputs L (1+/2+) 2 joint negative return conductors of load (3-/4-)
Terminals	plug-in-terminal block, 4-pole, max. 2,5 mm ²

Signalling

	Signalling terminal X31 (2 x 3-pole) for group signal (13/14/14)(14/14/14) of slots F1...F6/F10 (13= 1 x signal supply, 14= 5 x signal-outputs)
Rated voltage	DC 24 V (18...28 V)
Total current	max. 0,5 A Caution: please provide fast external protection 0.5 A or feed current-limited signal (e.g. DC-OK-output of power supply)
Terminals	2 plug-in terminal block, 3-pole, max. 2.5 mm ²

Technical data ($T_{amb} = 25\text{ °C}$, $U_B = \text{DC } 24\text{ V}$)

Termination

Supply terminals - terminal block (X21)	
Plug-in terminal block, 7-pole max. cable cross section flexible with wire end ferrule (with plastic sleeve) stripping length	0.75 – 10 mm ² 18 mm
load output / Minus- and signalling terminal block (X1...X6/X10/X31)	
Push-In-terminal block, 3-pole / 4-pole max. cable cross section flexible with wire end ferrule (with plastic sleeve) flexible with wire end ferrule (without plastic sleeve) stripping length with wire end ferrule	
	0.25 – 1.5 mm ² 0.25 – 2.5 mm ² 8 mm

General Data

Mounting	rail mounting to EN 60715 – 35 x 7.5
Temperature range	0...40 °C (without condensation)
Storage temperature	-20...+70 °C
Housing material	plastic
Protection class	to DIN 40050: terminals IP20, diods IP00
Insulation voltage	to IEC 60934: 0.5 kV
Dimensions	see drawings (tolerances to DIN ISO 286 part 1 IT13)
Mass	SVS18-06-C10 / approx 400 g SVS18-10-C10 / approx 630 g

Ordering information

Type

SVS18 power distribution system for ESS20-003, ESS30-S003, ESX10-103

- For short circuit current limited DC 24 V-applications
- Max. 25 A cont. load
- Integral group signalling terminals X31, DC 24 V / max. 0.5 A, have to be protected separately
- Incl. 1 isolated bridge for terminal L1 and L2 pushed in upon receipt
- Incl. 10 isolated bridges for load outputs, parallel connection of diodes Dx.1 and Dx.2, pushed in upon receipt
- Accessories: jumpers SB-11-P1-01-1-1A (for free slots), order separately

Version, max. number of circuit breakers on the power distribution system

6 circuit breakers (F1...F6)

10 circuit breakers (F1...F10)

Fitted version, load output and signalling terminals

C10 standard: completed fitted with push-in-terminals (max. 2.5 mm², without wire end ferrule)

SVS18 - 10 - C10 ordering example

Accessory: jumper, see Accessories

6

Notes

- The max. total current of 25 A must not be exceeded.
- The max. current load of the redundancy diodes of typically 1.5 A, max. 3 A per diode, must be strictly observed. In the event of parallel connection of the two diodes, a load current of typically 3 A (max. 6 A in limited continuous duty) must strictly be observed.
- The signal circuit (max. 0.5 A) has to be protected separately or supplied via the current-limited DC-o.k.-output of a switch-mode power supply.
- Jumpers type SB-S11-P1-01-1-1A have to be inserted into free slots.
- The user has to ensure that the proper cable cross section of the load circuit in question is chosen in relation to the rating of the load / circuit breakers.
- Technical data of the circuit breakers have to be observed.
- In addition special precautions have to be taken in the plant or machinery (e.g. use of a safety PLC) to prevent inadvertent start-up of (parts of) the system (cf. Machinery Directive 2006/42/EG and EN 60204-1, Safety of Machinery). In the event of a failure (short circuit/overload) the load circuit will be disconnected by circuit breakers.
- The power distribution system must only be installed by skilled personnel.
- It is exclusively meant for the use with low voltages (= 24 V).
- Only after expert installation may the assembly be connected to a power supply.
- After tripping of the circuit breaker and before reset, the cause of the tripping (short circuit or overload) must be remedied.
- The national and international standards (e.g. DIN VDE 0100 for Germany) must be observed with respect to installation and selection of cables.
- Connection to higher or not reliably disconnected voltages may be hazardous or cause damages.



Caution:

Warning of hot surface, the diodes could be hot, do not touch – risk of injury.

Mounting position

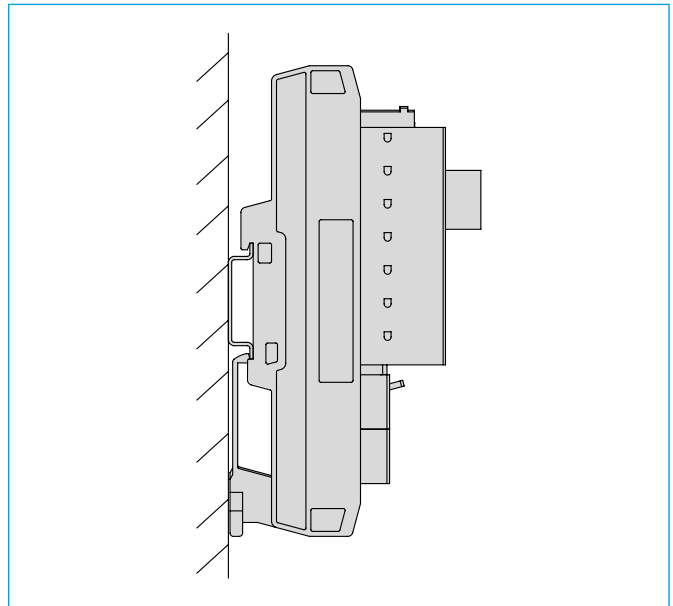

Wiring example: SVS18-06 with ESS20-003 and group signalling

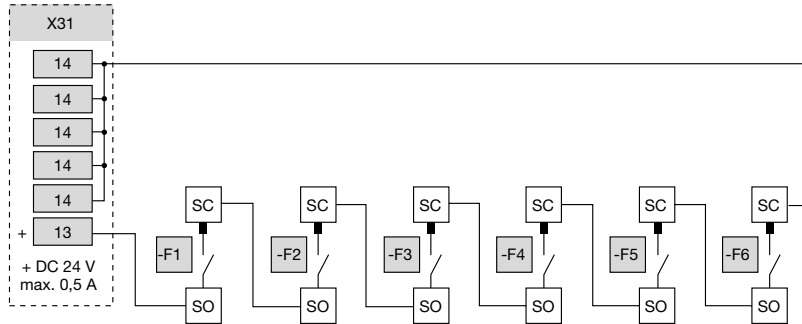

Wiring example: SVS18-10 with ESS20-003 and group signalling

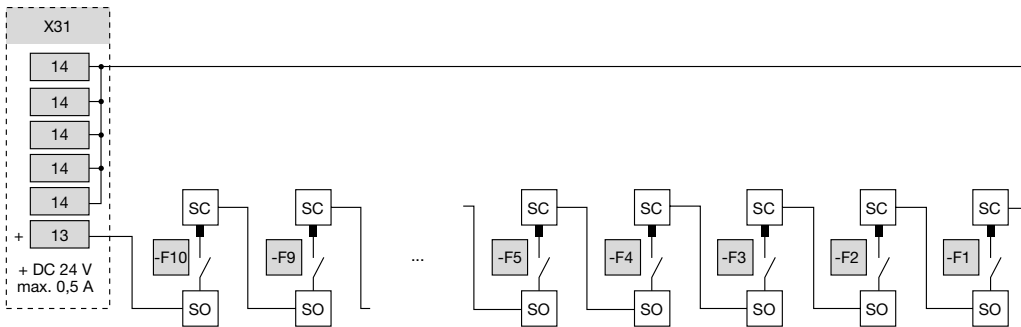

Schematic diagram SVS18-06-C10

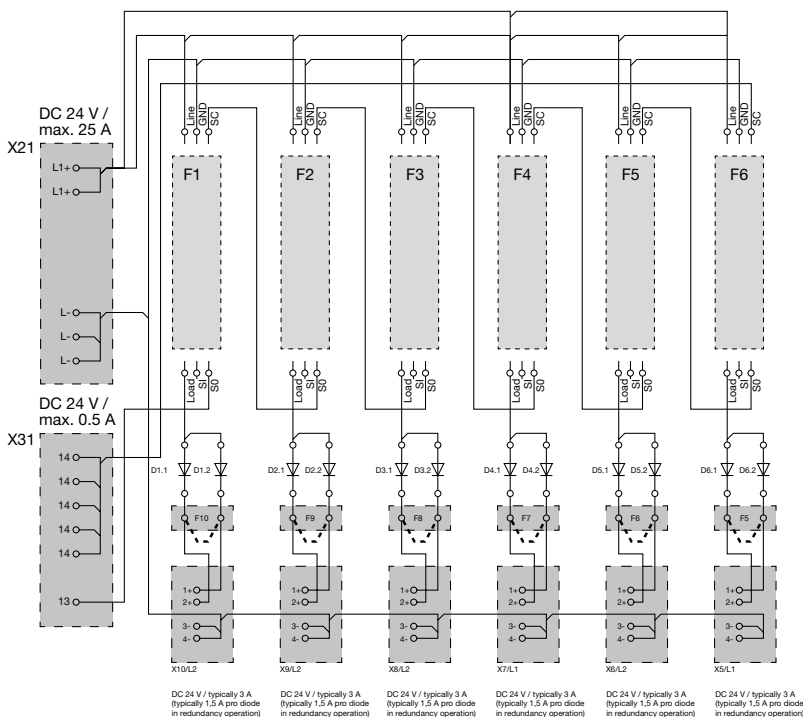

6

Schematic diagram SVS18-10-C10

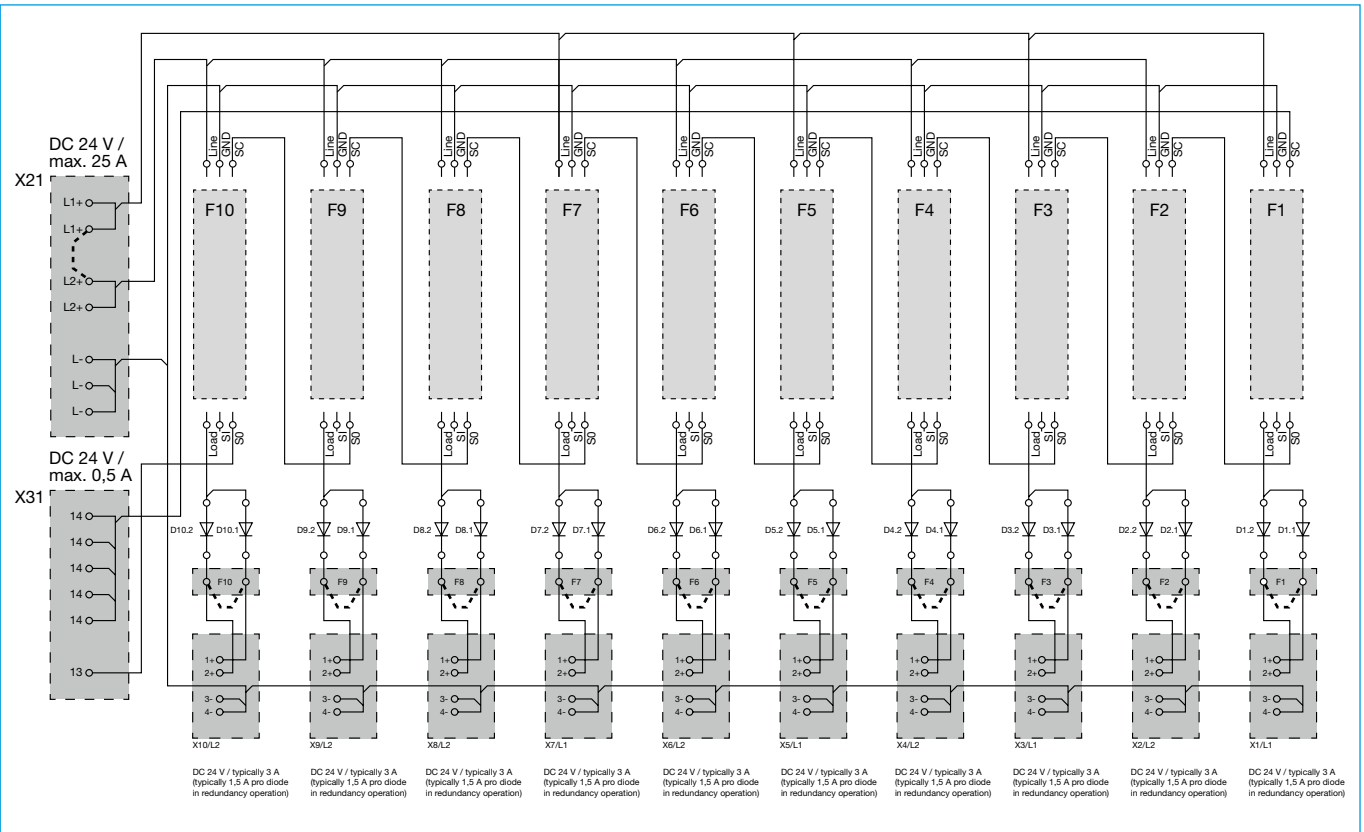

Dimensions: SVS18-06-C10

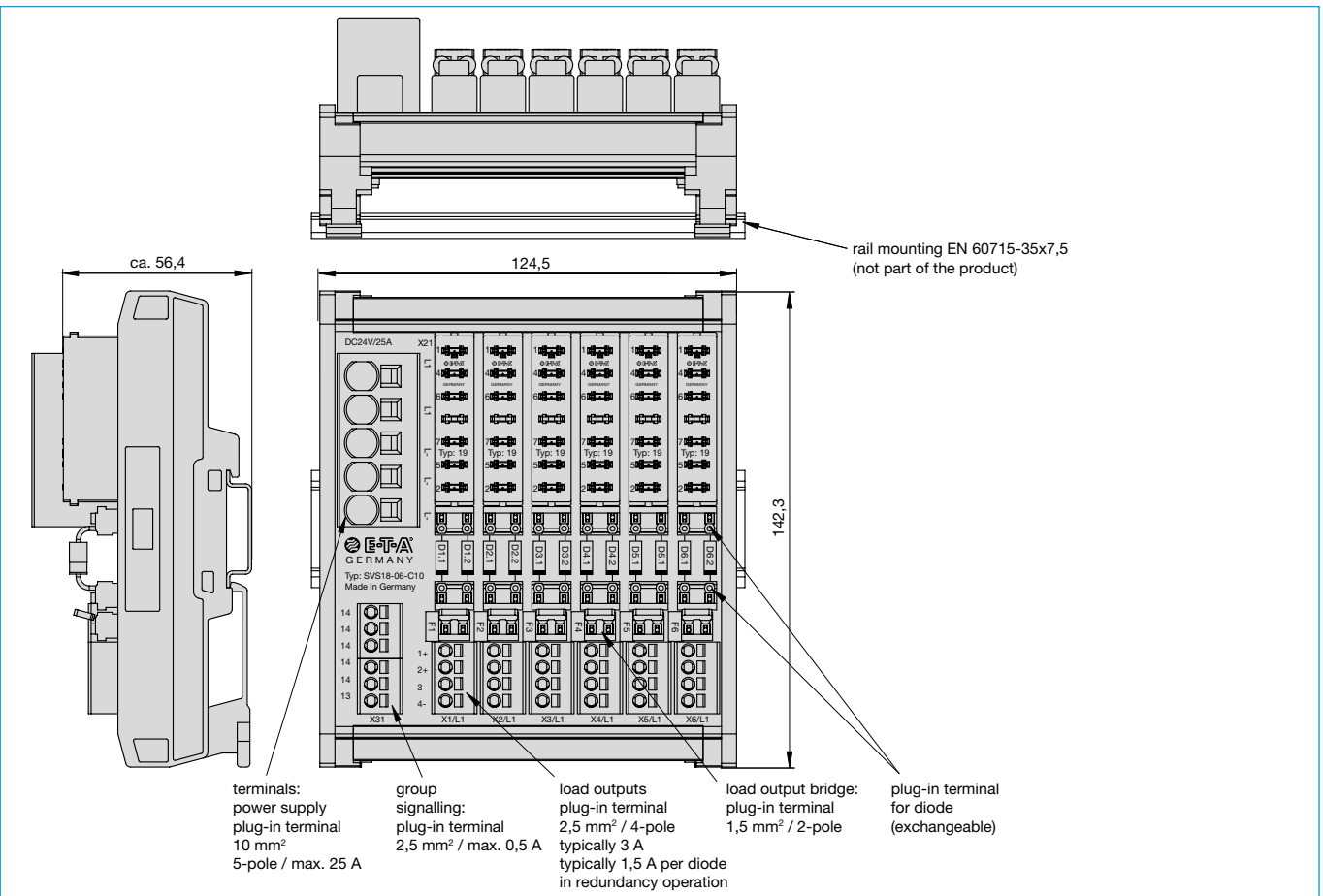

Dimensions: SVS18-10-C10

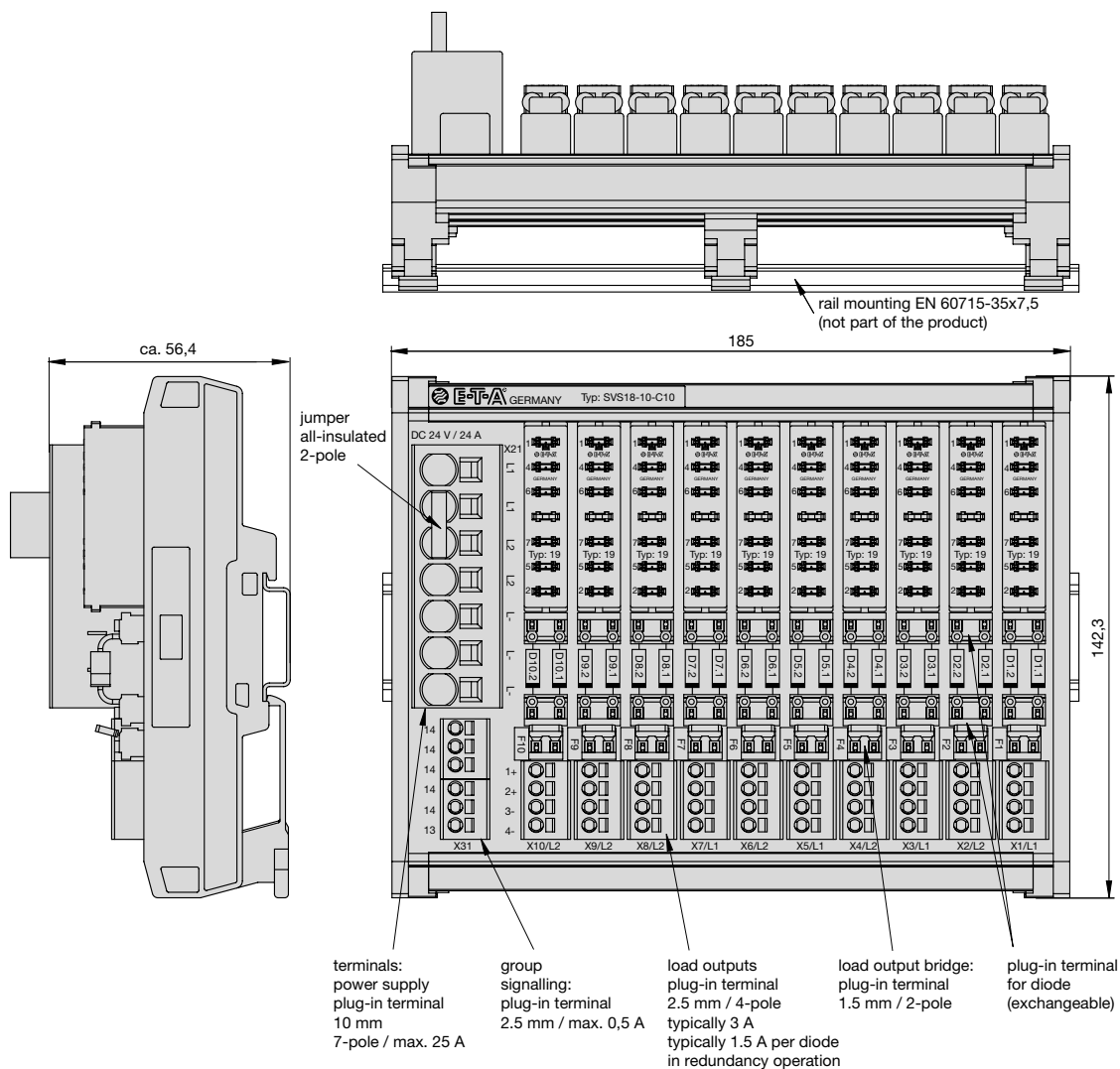

Application example: SVS18-6-C10 fitted with ESS20-003 and ESX10-103

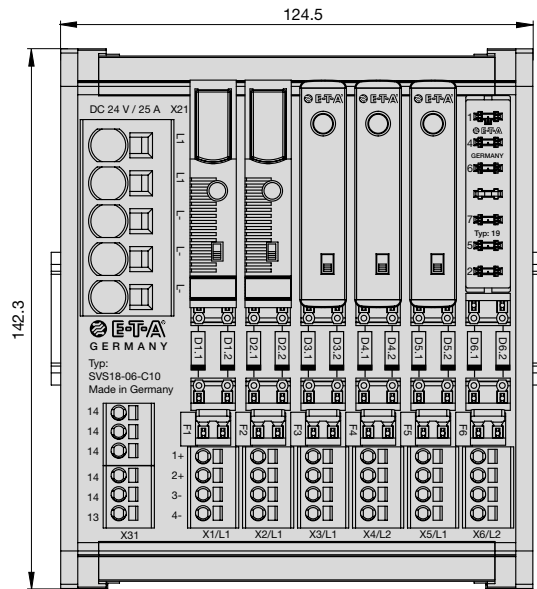
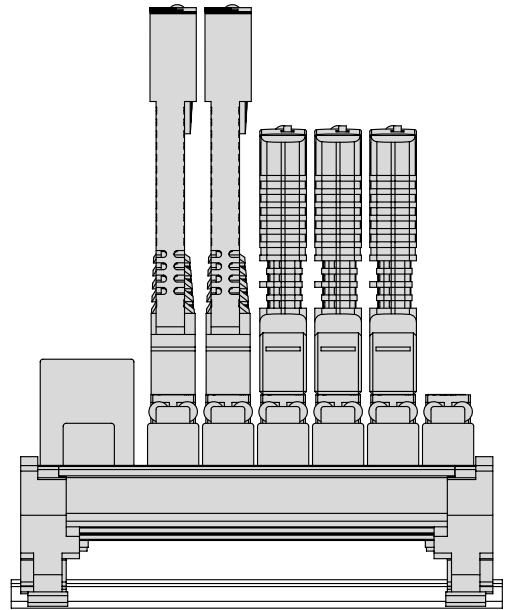
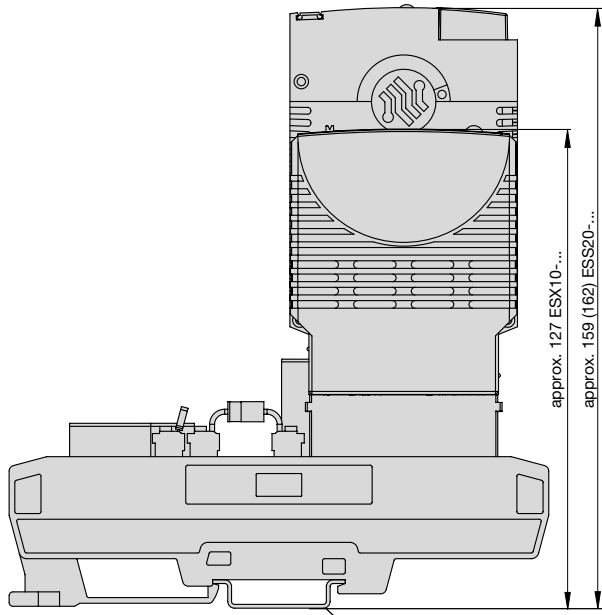

Application example: SVS18-10-C10 fitted with ESS20-003 and ESX10-103

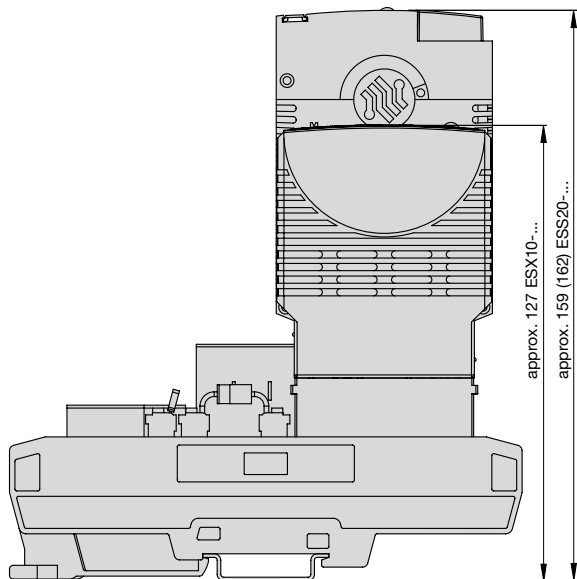

rail mounting EN 60715-35-7.5
(not part of the product)

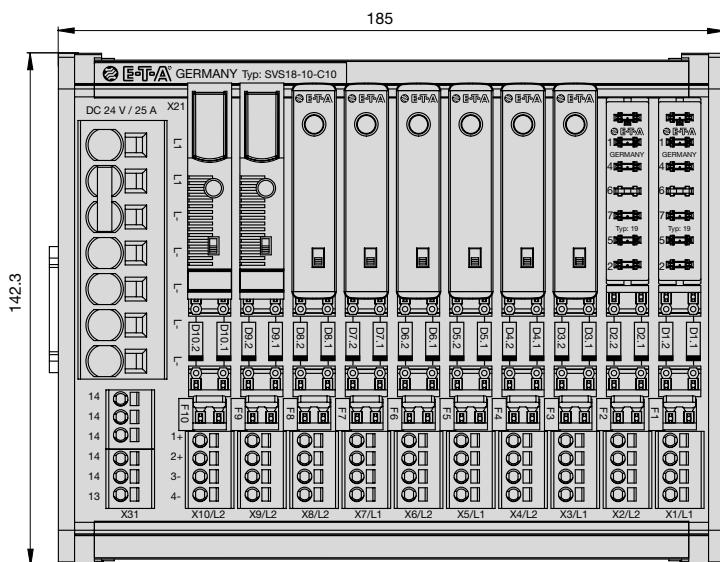
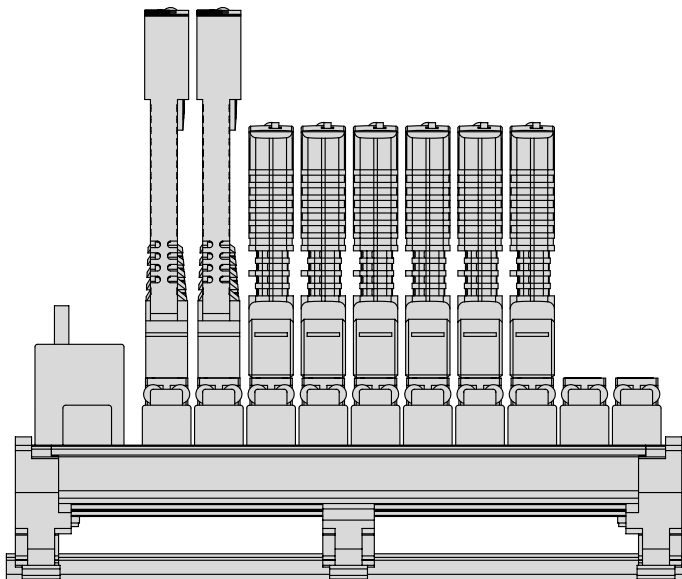

Plug-in modules (circuit breakers)
to be ordered separately.

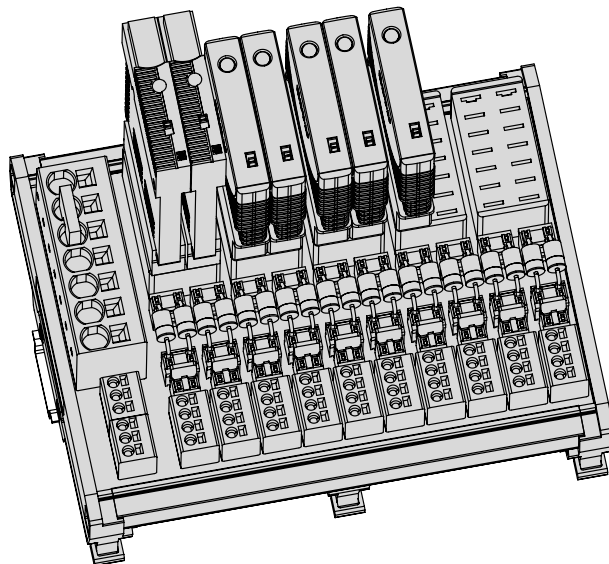

Application example: jumper instead of circuit breaker (e.g. ESX10-003)

If the power distribution system is not completely populated with circuit breakers, the open way can be closed with a plugged-in jumper type SB-S11-P1-01-1-1A.

The signalling pathway of the group signalling is as follows:

- feed-in of DC24V potential in X31 terminal (13)
- via all aux. make contacts SC/S0 of the fitted circuit breakers type ESX10-103 (or ESS20-003, ESS30-S003)
- back to the signal outputs of the group signal X31(14/14/14/14/14)

In operating condition (i.e. all circuit breakers plugged in and ON) the signalling pathway from X31/13 to X31/14 is closed.

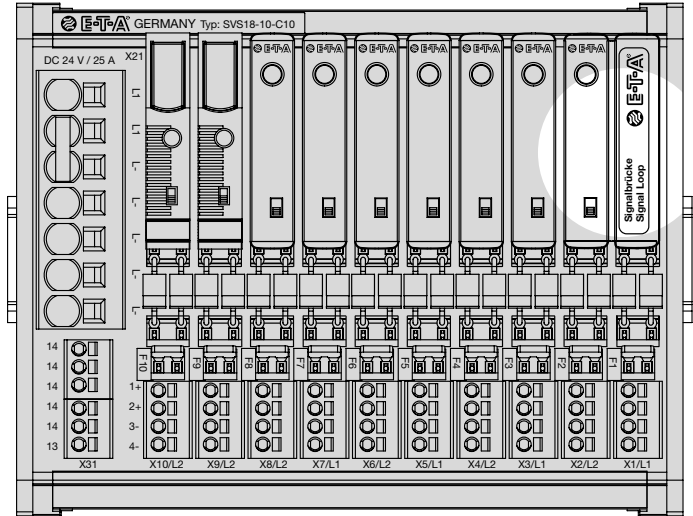

Accessories

Jumper SB-S11-P1-01-1-1A

