



Chipsmall Limited consists of a professional team with an average of over 10 year of expertise in the distribution of electronic components. Based in Hongkong, we have already established firm and mutual-benefit business relationships with customers from,Europe,America and south Asia,supplying obsolete and hard-to-find components to meet their specific needs.

With the principle of “Quality Parts,Customers Priority,Honest Operation,and Considerate Service”,our business mainly focus on the distribution of electronic components. Line cards we deal with include Microchip,ALPS,ROHM,Xilinx,Pulse,ON,Everlight and Freescale. Main products comprise IC,Modules,Potentiometer,IC Socket,Relay,Connector.Our parts cover such applications as commercial,industrial, and automotives areas.

We are looking forward to setting up business relationship with you and hope to provide you with the best service and solution. Let us make a better world for our industry!



Contact us

Tel: +86-755-8981 8866 Fax: +86-755-8427 6832

Email & Skype: info@chipsmall.com Web: www.chipsmall.com

Address: A1208, Overseas Decoration Building, #122 Zhenhua RD., Futian, Shenzhen, China



PART NUMBER CODING
SWT25X-U__C-S01-UU-UU

REVISIONS				
REV.	ECO. NO	DESCRIPTION	DATE	BY
A	2237	INITIAL RELEASE	05/24/2011	LH

MATERIAL & PLATING

RT = BRASS, .000015" MIN NICKEL UNDERPLATE, .000040" MIN PURE TIN, BRIGHT OVERALL (NOTE 7).
 PT = PHOSPHOR BRONZE, .000015" MIN NICKEL UNDERPLATE, .000040" MIN PURE TIN, BRIGHT OVERALL (NOTE 7).
 RP = BRASS, .000040" MIN NICKEL UNDERPLATE, GOLD FLASH OVERALL.

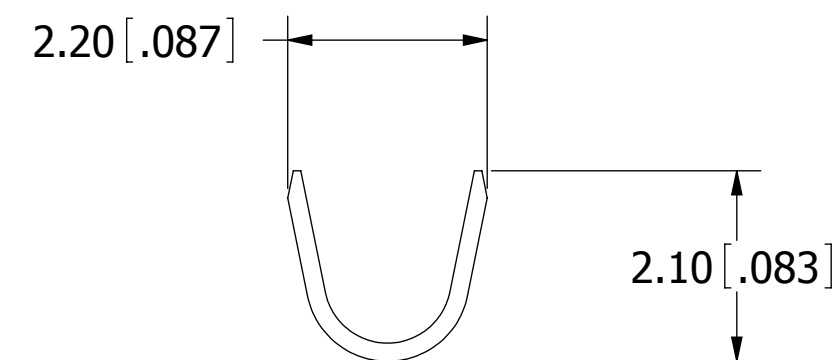
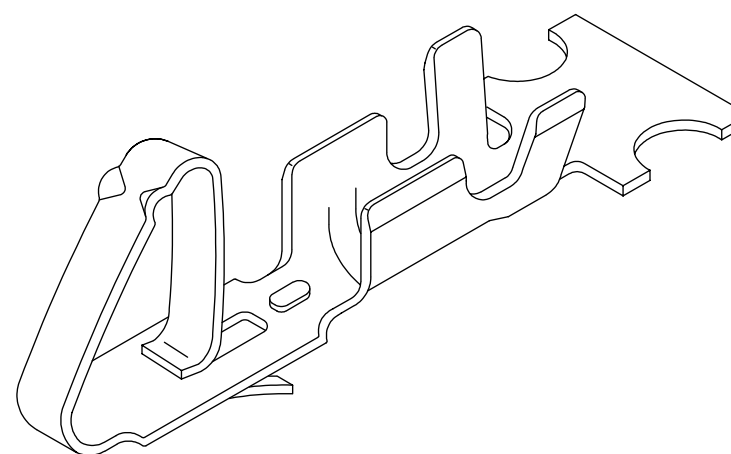
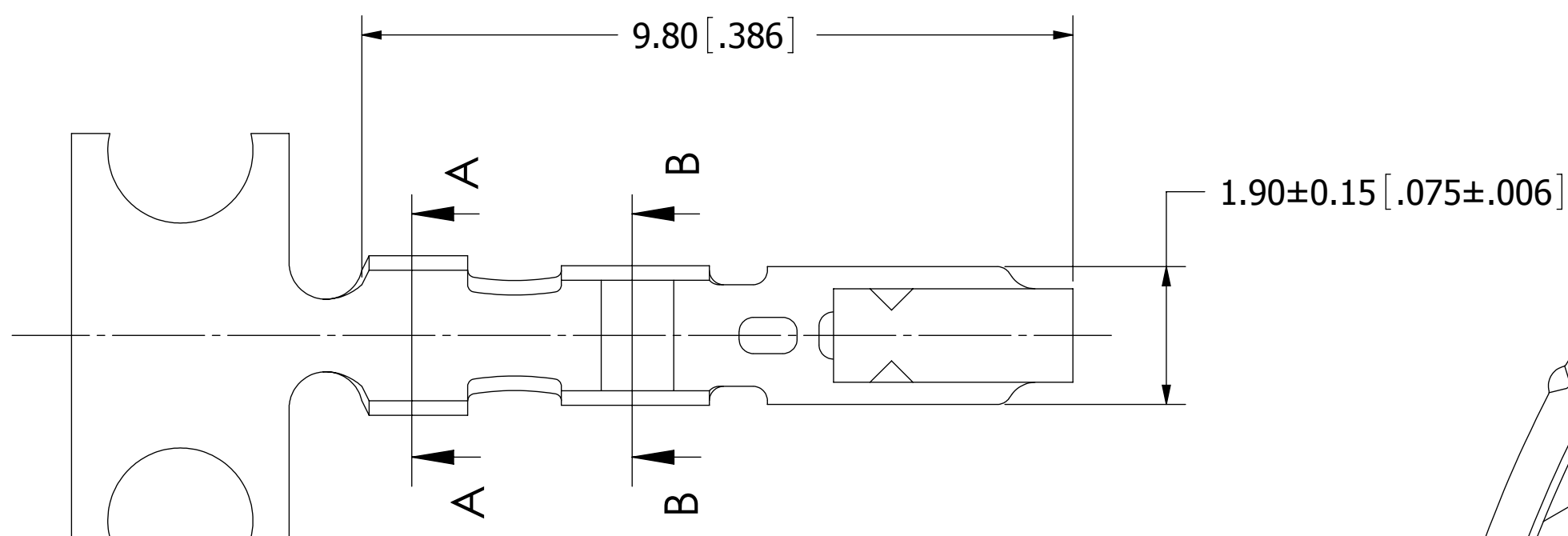

SECTION A-A

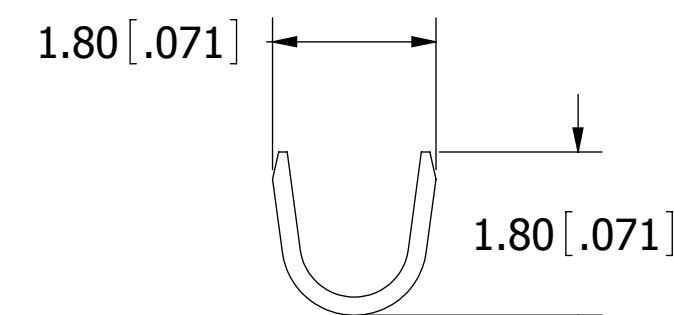
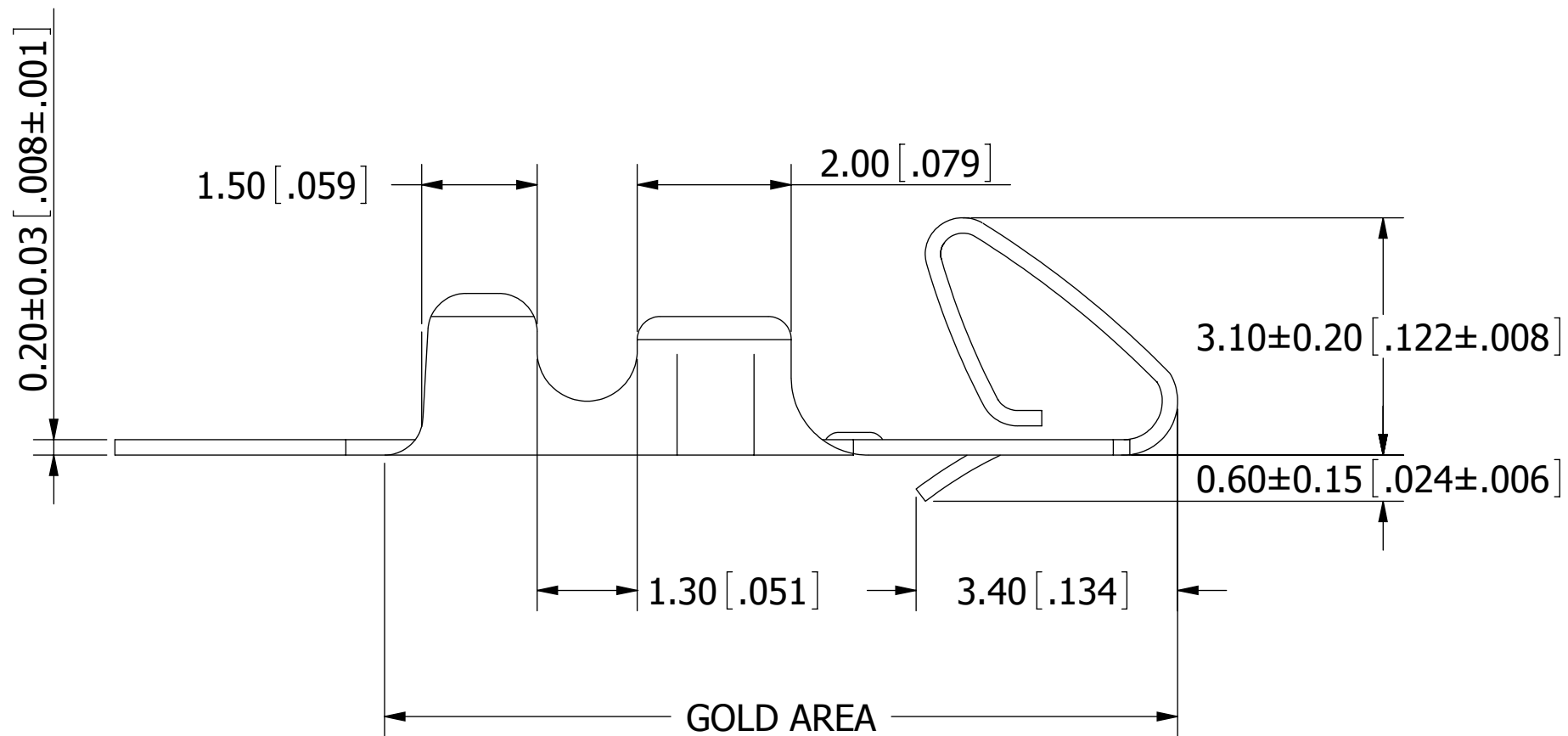

SECTION B-B

NOTES:

1. MATERIAL: SEE PART NUMBER CODING.
2. PLATING: SEE PART NUMBER CODING.
3. WIRE RANGE: AWG #20 - #26.
4. INSULATION O.D.: ϕ 1.35mm ~ ϕ 1.90mm.
5. QUANTITY PER REEL = 10,000 PIECES.
6. USED IN SWH25X SERIES HOUSING.
7. PLATING BEFORE STAMPING/FORMING.

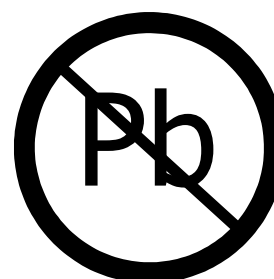

RoHS COMPLIANT

UNLESS OTHERWISE SPECIFIED: DIMENSIONS ARE IN MM[INCHES]	DRAWN	DATE	NAME	
		05/24/2011	LH	
TOLERANCES: ANGULAR: .X= ± 0.3 [.01] .XX= ± 0.30 [.012]	THE INFORMATION HEREIN CONTAINS PROPRIETARY INFORMATION OF SULLINS ELECTRONICS AND IS NOT TO BE REPRODUCED, USED OR DISCLOSED TO OTHERS FOR ANY PURPOSE EXCEPT AS SPECIFICALLY AUTHORIZED IN WRITING BY AN OFFICER OF SULLINS ELECTRONICS.			
	TITLE CRIMP TERMINAL - SWH25X			
INTERPRET DIMENSIONS AND TOLERANCING PER: ASME Y14.5M-2009	PART NUMBER SWT25X-U__C-S01-UU-UU			
	SIZE	CAGE CODE	DWG. NO.	REV
	C	54453	11631	A
SCALE: 12:1			SHEET 1 OF 1	