



Chipsmall Limited consists of a professional team with an average of over 10 year of expertise in the distribution of electronic components. Based in Hongkong, we have already established firm and mutual-benefit business relationships with customers from,Europe,America and south Asia,supplying obsolete and hard-to-find components to meet their specific needs.

With the principle of “Quality Parts,Customers Priority,Honest Operation,and Considerate Service”,our business mainly focus on the distribution of electronic components. Line cards we deal with include Microchip,ALPS,ROHM,Xilinx,Pulse,ON,Everlight and Freescale. Main products comprise IC,Modules,Potentiometer,IC Socket,Relay,Connector.Our parts cover such applications as commercial,industrial, and automotives areas.

We are looking forward to setting up business relationship with you and hope to provide you with the best service and solution. Let us make a better world for our industry!



## Contact us

Tel: +86-755-8981 8866 Fax: +86-755-8427 6832

Email & Skype: info@chipsmall.com Web: www.chipsmall.com

Address: A1208, Overseas Decoration Building, #122 Zhenhua RD., Futian, Shenzhen, China



# SX1272MB2DAS

---

## Hardware Description

---





## 1 Introduction

The SX1272/73 transceivers feature the LoRa™ long range modem that provides ultra-long range spread spectrum communication and high interference immunity whilst minimizing current consumption. Using Semtech's patented LoRa™ modulation technique SX1272/73 can achieve a sensitivity of over -137 dBm using a low cost crystal and bill of materials. The high sensitivity combined with the integrated +20 dBm power amplifier yields industry leading link budget making it optimal for any application requiring range or robustness. LoRa™ also provides significant advantages in both blocking and selectivity over conventional modulation techniques, solving the traditional design compromise between range, interference immunity and energy consumption. These devices also support high performance (G)FSK modes for systems including WMBus, IEEE802.15.4g. The SX1272/73 deliver exceptional phase noise, selectivity, receiver linearity and IIP3 for significantly lower current consumption than competing devices.

## 2 Ordering Information

When ordering, please refer to the following parts numbers:

**SX1272MB2DAS**

SX1272MB2xAS version + 868 / 915 MHz Compatible Antenna

The SX1272MB2DAS can be ordered in quantities from various distributors. Please visit the Semtech webpage to find your closest reseller.

<https://developer.mbed.org/components/SX1272MB2xAS/>

## 3 SX1272MB2xAS

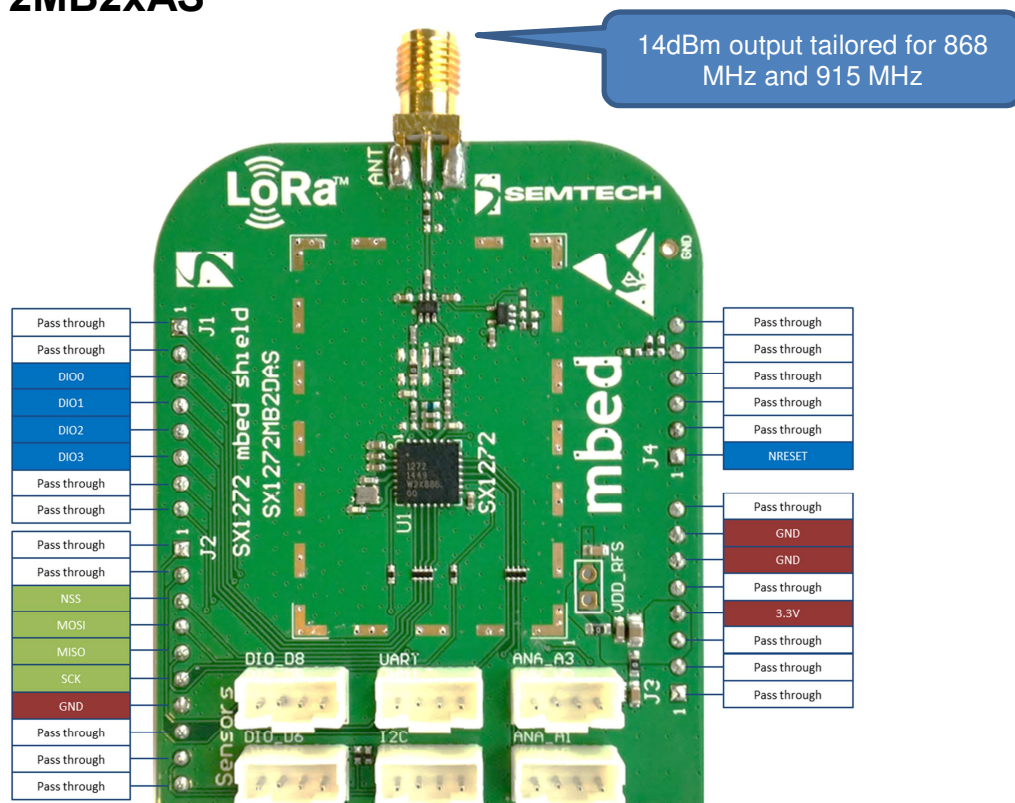

## 4 MBED Libraries

MBED libraries can be downloaded from Semtech webpage on MBED.

<https://developer.mbed.org/components/SX1272MB2xAS/>

## 5 Connectivity

The SX1272MB2xAS is controlled through the SPI bus at a maximum speed of 10Mbps. The connections are identical on each board so that the same software can be used on any boards. All “Pass through” pins are not used in the operations of the SX1272MB2xAS boards and can therefore be used in connections of other boards for various purposes. The I2C and UART have especially been let free so that a variety of sensor can be connected to the boards, and thus enable long distance control of them.

<b>SX1272MB2xAS</b>	<b>MBED Pin</b>
SCK	D13
MOSI	D11
MISO	D12
NSS	D10
DIO0	D2
DIO1	D3
DIO2	D4
DIO3	D5
NRESET	A0

## 6 Contact Information

**Semtech Corporation**  
**Wireless & Sensing Products**  
**Division 200 Flynn Road, Camarillo, CA 93012**  
**Phone: (805) 498-2111**  
**Fax: (805) 498-3804**  
**E-mail: [sales@semtech.com](mailto:sales@semtech.com)**  
**[support\\_rf@semtech.com](mailto:support_rf@semtech.com)**  
**Internet: <http://www.semtech.com>**