



Chipsmall Limited consists of a professional team with an average of over 10 year of expertise in the distribution of electronic components. Based in Hongkong, we have already established firm and mutual-benefit business relationships with customers from,Europe,America and south Asia,supplying obsolete and hard-to-find components to meet their specific needs.

With the principle of “Quality Parts,Customers Priority,Honest Operation,and Considerate Service”,our business mainly focus on the distribution of electronic components. Line cards we deal with include Microchip,ALPS,ROHM,Xilinx,Pulse,ON,Everlight and Freescale. Main products comprise IC,Modules,Potentiometer,IC Socket,Relay,Connector.Our parts cover such applications as commercial,industrial, and automotives areas.

We are looking forward to setting up business relationship with you and hope to provide you with the best service and solution. Let us make a better world for our industry!



## Contact us

Tel: +86-755-8981 8866 Fax: +86-755-8427 6832

Email & Skype: info@chipsmall.com Web: www.chipsmall.com

Address: A1208, Overseas Decoration Building, #122 Zhenhua RD., Futian, Shenzhen, China



### ADVANCED COMMUNICATIONS & SENSING

#### GENERAL DESCRIPTION

The SX8674, SX8675 and SX8676 belong to a family of high performance haptics enabled multitouch 4/5-wire resistive touch screen controller with proximity detection, optimized for hand held applications such as mobile phones, portable music players, game machines, point-of-sales terminal and other consumer and industrial applications. They feature a wide input supply range from 2.3V to 3.6V.

The controller computes touch screen X-Y coordinates and touch pressure with a precision, low power 12-bit analog-digital converter. On-chip data averaging processing algorithms can be activated to reduce host activity and suppress system noise. The processing core features low power modes which intelligently minimize current in operation as well as in automatic shut-down.

Multitouch feature enables detection of 2 fingers on the touchscreen and several gestures like rotation and pinch/stretch.

A capacitive proximity detection circuit has been integrated into the SX8674 and SX8676 to enable host controlled power management for battery applications. Proximity detection above 5 cm is possible using either the resistive touch screen as the sensor or with a single conductive plate, with communication to the host via the serial interface.

The SX8674 and SX8675 also integrate a haptics motor driver for Linear Resonant Actuator (LRA) and Eccentric Rotating Mass (ERM) micro motors with up to 250mA drive current. Haptics control can be performed using either an external PWM signal or the I2C serial interface, providing simple host interfacing and minimizing its I/O requirement.

Integrated very high ESD protection, of up to  $\pm 15\text{kV}$  on display inputs not only saves cost and board area, but also increases application reliability.

The three devices have an ambient operating temperature range of  $-40^\circ\text{C}$  to  $+85^\circ\text{C}$ , and are offered in both a 4mm x 4mm, 20-lead QFN package and 2.07mm x 2.07mm 19-lead CSP package for space-conscious applications.

#### TYPICAL APPLICATIONS

- Game Machines, Portable Music Players
- Mobile Phones
- DSC, DVR, Phones
- POS/POI Terminals
- Touch-Screen Monitors

#### ORDERING INFORMATION

Part Number	Package	Marking
SX8674IWLTRT	QFN-20	RA39
SX8674ICSTRT	WLCSP-19	
SX8675IWLTRT	QFN-20	RF9E
SX8675ICSTRT	WLCSP-19	
SX8676IWLTRT	QFN-20	RKL9
SX8676ICSTRT	WLCSP-19	
SX8674EVK	Evaluation Kit	-

#### KEY PRODUCT FEATURES

- Low Voltage Operation
  - 2.3V to 3.6V Supply
  - Integrated Low Drop Out (LDO) Regulator
- Low Power Consumption
  - 30uA@2.3V 8ksp/s (ESR)
  - 0.4uA Shut-Down Current
- 4/5-Wire Touchscreen Interface
  - Precision, Ratiometric 12-bit ADC
  - Up to 5000 (X-Y) coordinates/second (c/s)
  - Programmable Digital Filtering/Averaging
  - Touch Pressure Measurement (4-Wire)
  - Programmable Operating Mode (Manual, Pen Detect, Pen Trigger)
- Capacitive Proximity Sensing (SX8674/76)
  - No Additional Components Required
  - Uses Resistive Touchscreen or a Simple Conductive Area as the Sensor
  - >5 cm Detection Distance
  - 8uA @ 200ms Scan Period
  - Fully Programmable (Sensitivity, etc)
- Haptics Driver for LRA and ERM (SX8674/75)
  - Haptics Waveform Generation Control (I2C or PWM Input)
  - Short Circuit Protection
  - Early Warning and Over-Temperature Monitoring and Protection
- 400kHz I2C Serial Interface
- Several Host Operating Modes Available
  - Maskable Interrupt Output (NIRQ)
  - Real-time Events Monitoring (AUX1-3)
  - Polling (I2C)
- Hardware, Software, and Power-On Reset
- $-40^\circ\text{C}$  to  $+85^\circ\text{C}$  Operating Temperature Range
- 15kV HBM & IEC ESD Protection
- Small Footprint Packages
- Pb & Halogen Free, RoHS/WEEE compliant

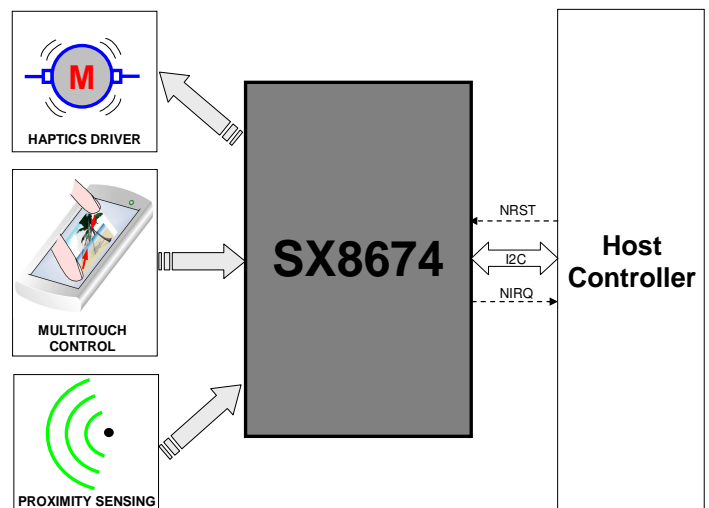

**Table of Contents**

<b>GENERAL DESCRIPTION</b> .....	<b>1</b>
<b>TYPICAL APPLICATIONS</b> .....	<b>1</b>
<b>ORDERING INFORMATION</b> .....	<b>1</b>
<b>KEY PRODUCT FEATURES</b> .....	<b>1</b>
<b>1 GENERAL DESCRIPTION</b> .....	<b>4</b>
<b>1.1 Marking Information</b>	<b>4</b>
1.1.1 SX8674	4
1.1.2 SX8675	4
1.1.3 SX8676	4
<b>1.2 Pin Diagrams</b>	<b>5</b>
1.2.1 QFN Package	5
1.2.2 CSP Package	5
<b>1.3 Pin Description</b>	<b>6</b>
<b>1.4 Block Diagram</b>	<b>7</b>
<b>2 ELECTRICAL CHARACTERISTICS</b> .....	<b>9</b>
<b>2.1 Absolute Maximum Ratings</b>	<b>9</b>
<b>2.2 Thermal Characteristics</b>	<b>9</b>
<b>2.3 Electrical Specifications</b>	<b>9</b>
<b>3 TYPICAL OPERATING CHARACTERISTICS</b> .....	<b>12</b>
<b>4 TOUCHSCREEN INTERFACE</b> .....	<b>13</b>
<b>4.1 Introduction</b>	<b>13</b>
<b>4.2 Coordinates Measurement</b>	<b>14</b>
4.2.1 4-wire Touchscreen	14
4.2.2 5-wire Touchscreen	15
<b>4.3 Pressure Measurement (4-wire only)</b>	<b>15</b>
4.3.1 Bias Time (POWDLY)	16
<b>4.4 Pen Detection</b>	<b>16</b>
<b>4.5 Multitouch Measurement (4-wire only)</b>	<b>17</b>
<b>4.6 Digital Processing</b>	<b>18</b>
<b>4.7 Host Operation</b>	<b>19</b>
4.7.1 Overview	19
4.7.2 Manual Mode (MAN)	19
4.7.3 Pen Detect Mode (PENDET)	21
4.7.4 Pen Trigger Mode (PENTRG)	21
4.7.5 Maximum Throughput vs. TOUCHRATE setting	22
<b>5 PROXIMITY SENSING INTERFACE (SX8674/76)</b> .....	<b>24</b>
<b>5.1 Introduction</b>	<b>24</b>
<b>5.2 Analog Front-End (AFE)</b>	<b>25</b>
5.2.1 Capacitive Sensing Basics	25
5.2.2 AFE Block Diagram	26
5.2.3 Capacitance-to-Voltage Conversion (C-to-V)	27
5.2.4 Shield Control	27
5.2.5 Offset Compensation	27
5.2.6 Analog-to-Digital Conversion (ADC)	28
<b>5.3 Digital Processing</b>	<b>28</b>
5.3.1 Overview	28
5.3.2 PROXRAW Update	29
5.3.3 PROXUSEFUL Update	30

**ADVANCED COMMUNICATIONS & SENSING**

5.3.4	PROXAVG Update	31
5.3.5	PROXDIFF Update	33
5.3.6	PROXSTAT Update	33
<b>5.4</b>	<b>Host Operation</b>	<b>34</b>
5.4.1	General Description	34
5.4.2	Proximity Sensing vs Touch Operations	34
5.4.3	Minimum Scan Period (i.e. PROXSCANPERIOD)	36
<b>6</b>	<b>HAPTICS INTERFACE (SX8674/75)</b> .....	<b>37</b>
6.1	Introduction	37
6.2	ERM Load	37
6.2.1	Introduction	37
6.2.2	PWM Mode	38
6.2.3	I2C Mode	38
6.3	LRA Load	38
6.3.1	Introduction	38
6.3.2	PWM Mode	39
6.3.3	I2C Mode	39
6.4	Short-Circuit Protection	39
<b>7</b>	<b>TEMPERATURE SENSOR</b> .....	<b>40</b>
<b>8</b>	<b>INTERRUPT (NIRQ)</b> .....	<b>41</b>
8.1	Introduction	41
8.2	Registers Overview	41
8.2.1	RegIrqMsk	41
8.2.2	RegIrqSrc	41
8.2.3	RegStat	41
8.3	Host Procedure	41
<b>9</b>	<b>AUXILIARY PINS (AUX1/AUX2/AUX3)</b> .....	<b>42</b>
<b>10</b>	<b>RESET</b> .....	<b>43</b>
10.1	Hardware (POR and NRST)	43
10.2	Software (RegReset)	43
10.3	ESD Event (RESETSTAT)	43
<b>11</b>	<b>I2C INTERFACE</b> .....	<b>44</b>
11.1	Introduction	44
11.2	I2C Address	44
11.3	Write Register	44
11.4	Read Register	45
11.5	Write Command (Touchscreen Interface)	45
11.6	Read Channel (Touchscreen Interface)	46
<b>12</b>	<b>REGISTERS DETAILED DESCRIPTION</b> .....	<b>48</b>
<b>13</b>	<b>APPLICATION INFORMATION</b> .....	<b>60</b>
13.1	Typical Application Circuit	60
13.2	External Components Recommended Values	60
13.3	Multitouch Gestures	60
13.3.1	Pinch/Stretch	60
13.3.2	Rotate	61
<b>14</b>	<b>PACKAGING INFORMATION</b> .....	<b>62</b>
14.1	QFN Package	62
14.2	CSP Package	63

**1 GENERAL DESCRIPTION**
**1.1 Marking Information**
**1.1.1 SX8674**

Figure 1 – Marking Information – QFN(left) – CSP(right)

**1.1.2 SX8675**

Figure 2 – Marking Information – QFN(left) – CSP(right)

**1.1.3 SX8676**

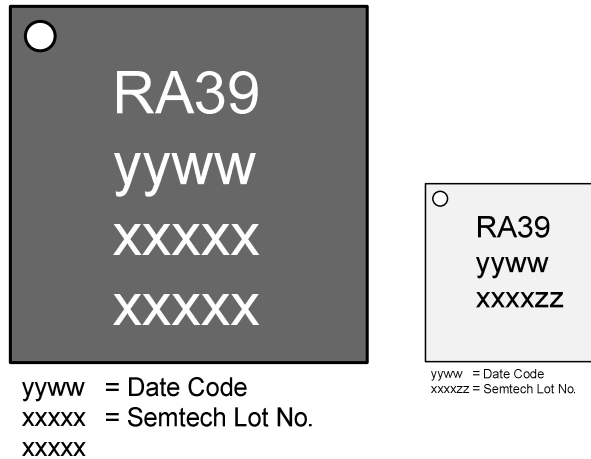
Figure 3 – Marking Information – QFN(left) – CSP(right)

## ADVANCED COMMUNICATIONS & SENSING

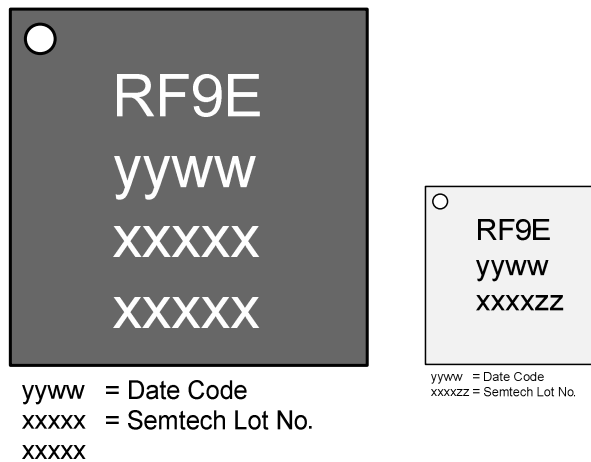
### 1.2 Pin Diagrams

#### 1.2.1 QFN Package

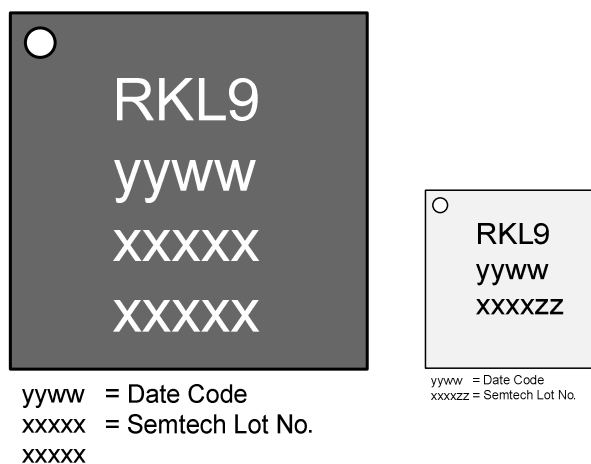
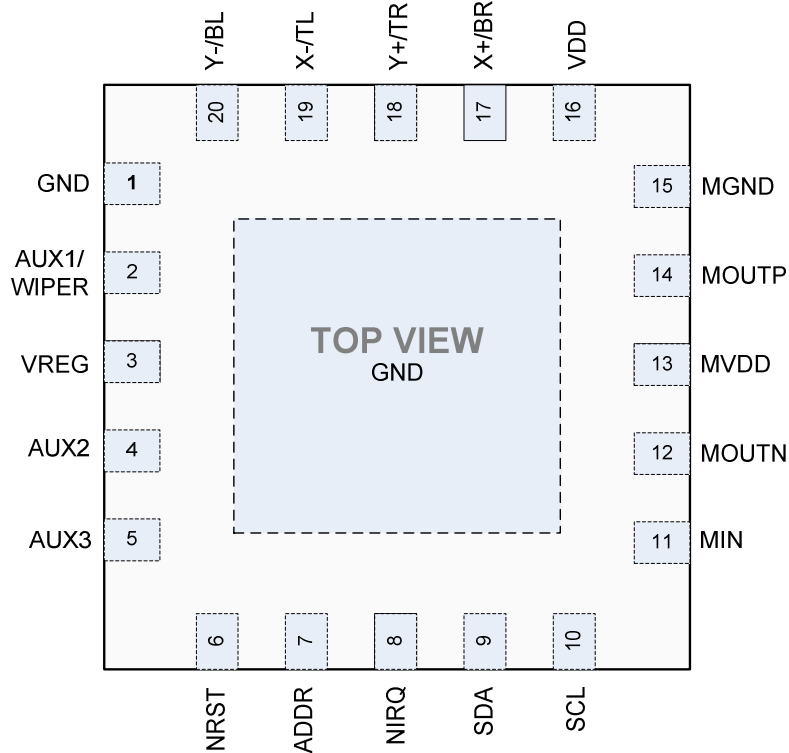

Figure 4 – Pin Diagram – QFN

Note that haptics pins (MVDD, MGND, MIN, MOUTN, MOUTP) are not used on SX8676. (Cf. §1.3)

#### 1.2.2 CSP Package

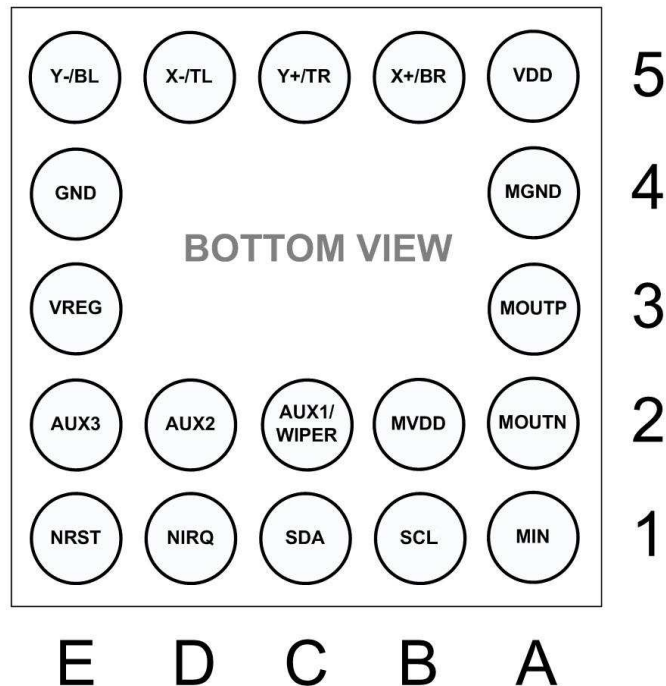

Figure 5 – Pin Diagram - CSP

Note that haptics pins (MVDD, MGND, MIN, MOUTN, MOUTP) are not used on SX8676. (Cf. §1.3)

**ADVANCED COMMUNICATIONS & SENSING**
**1.3 Pin Description**

Name	Type	Description
VDD	P	Main Power Supply
GND	P	Main Ground
VREG	P	Internal Regulator Output (must be connected to an external capacitor; see §13)
MVDD	P	SX8674/75 : Haptics Motor Power Supply SX8676 : Not used, connect to VDD.
MGND	P	SX8674/75 : Haptics Motor Ground (must be electrically connected to GND) SX8676 : Not used, connect to GND.
MOUTP	AO	SX8674/75 : Haptics Motor Positive Drive SX8676 : Not used, do not connect.
MOUTN	AO	SX8674/75 : Haptics Motor Negative Drive SX8676 : Not used, do not connect.
MIN	DI	SX8674/75 : Haptics Motor PWM/Clock Input SX8676 : Not used, connect to GND.
X+/BR	A	<ul style="list-style-type: none"> <li>• 4-wire Touchscreen : X+ Electrode</li> <li>• 5-wire Touchscreen : Bottom Right (BR) Electrode</li> </ul>
Y+/TR	A	<ul style="list-style-type: none"> <li>• 4-wire Touchscreen : Y+ Electrode</li> <li>• 5-wire Touchscreen : Top Right (TR) Electrode</li> </ul>
X-/TL	A	<ul style="list-style-type: none"> <li>• 4-wire Touchscreen : X- Electrode</li> <li>• 5-wire Touchscreen : Top Left (TL) Electrode</li> </ul>
Y-/BL	A	<ul style="list-style-type: none"> <li>• 4-wire Touchscreen : Y- Electrode</li> <li>• 5-wire Touchscreen : Bottom Left (BL) Electrode</li> </ul>
AUX1/WIPER	D/A	<ul style="list-style-type: none"> <li>• 4-wire Touchscreen : First Programmable Auxiliary Function (see §9)</li> <li>• 5-wire Touchscreen : WIPER Electrode</li> </ul>
AUX2	D/A	Second Programmable Auxiliary Function (see §9)
AUX3	D/A	Third Programmable Auxiliary Function (see §9)
ADDR	DI	I2C Address Selection (QFN only, internally connected to GND on CSP)
SCL	DI	I2C Clock Input
SDA	DIO	I2C Data Input/Output
NIRQ	DO	Interrupt Output (active low)
NRST	DI	Reset Input (active low)

A/D/I/O/P: Analog/Digital/Power/Input/Output

*Table 1 – Pin Description*

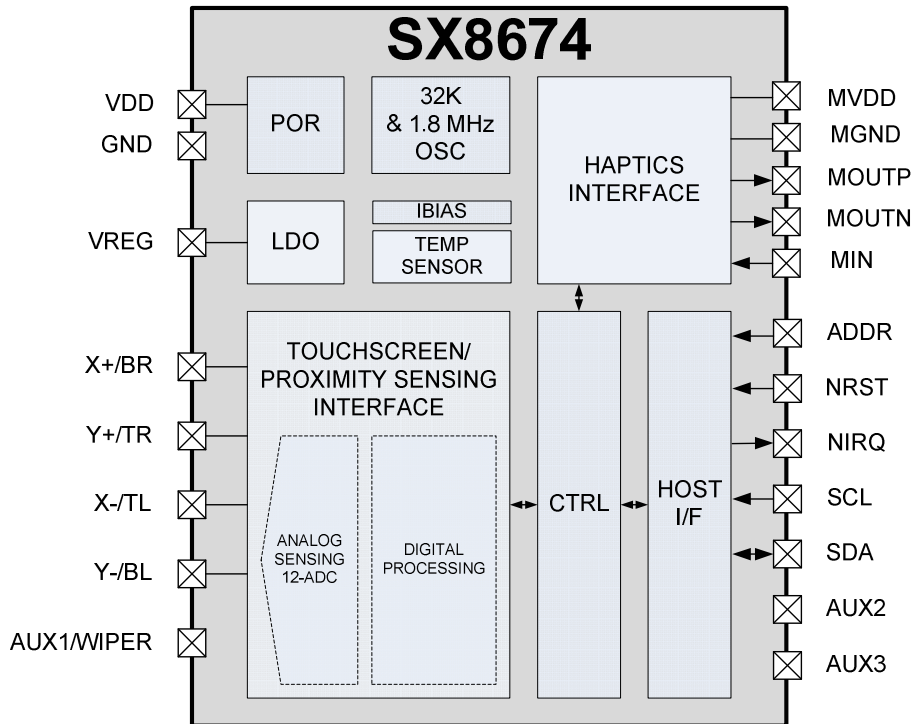
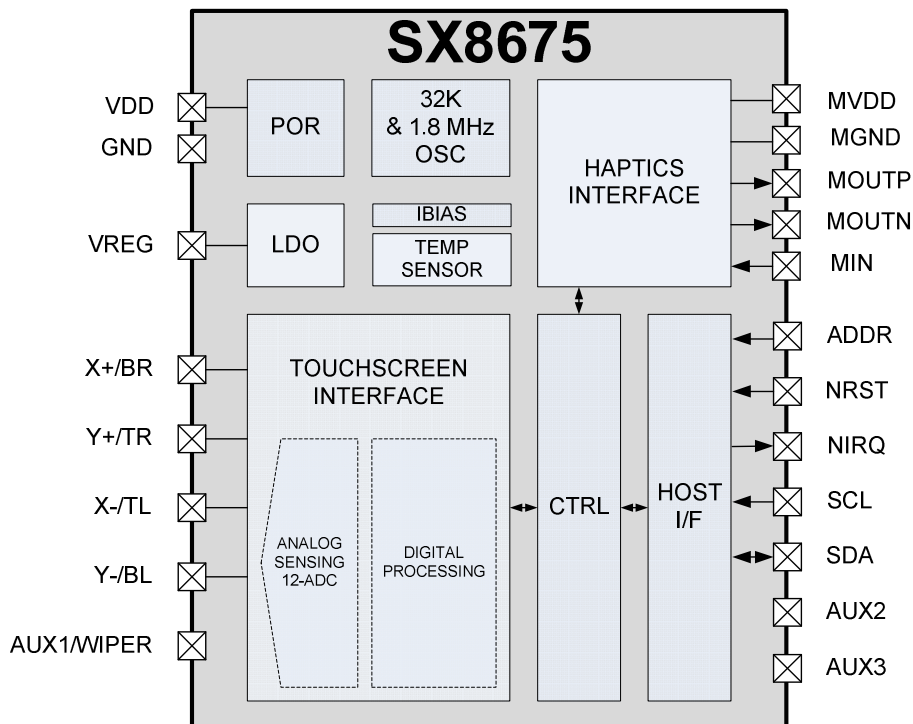
**ADVANCED COMMUNICATIONS & SENSING**
**1.4 Block Diagram**

*Figure 6 – SX8674 Block Diagram*

*Figure 7 – SX8675 Block Diagram*



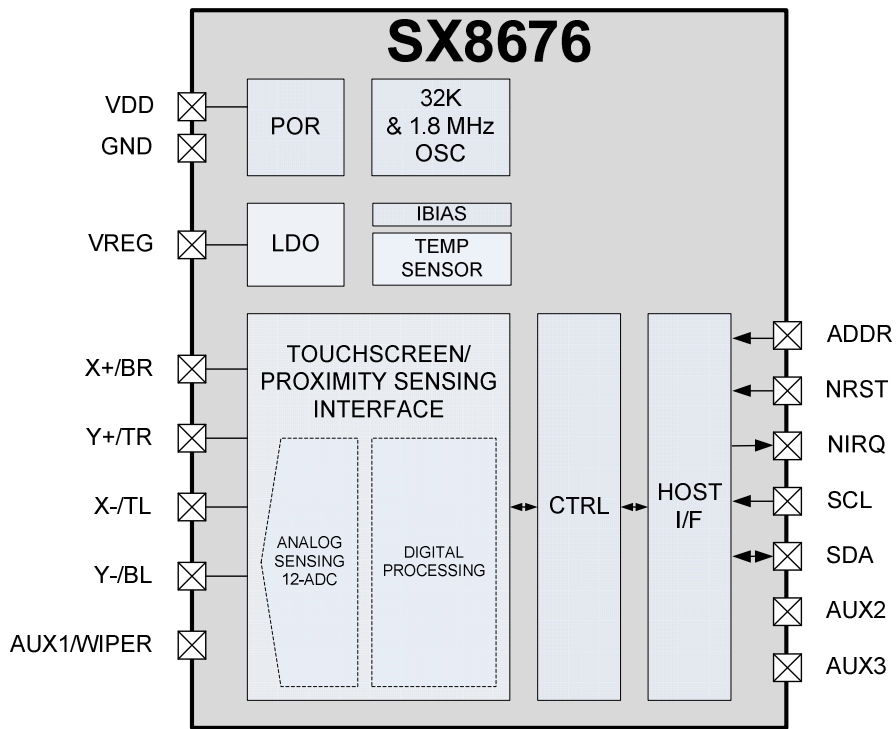

Figure 8 – SX8676 Block Diagram

**ADVANCED COMMUNICATIONS & SENSING**
**2 ELECTRICAL CHARACTERISTICS**
**2.1 Absolute Maximum Ratings**

Stress above the limits listed in the following table may cause permanent failure. Exposure to absolute ratings for extended time periods may affect device reliability. The limiting values are in accordance with the Absolute Maximum Rating System (IEC 134). All voltages are referenced to ground (GND).

Symbol	Description	Conditions	Min	Max	Unit
VABS	Voltage applied on any pin		- 0.5	3.9	V
VESDHBM	Electrostatic handling Human Body Model (HBM)	X+/BR, Y+/TR, X-/TL, Y-/BL, VDD, MVDD	+/-15 <sup>(1)</sup> , +/-8 <sup>(2)</sup>		kV
		Other pins	+/-8 <sup>(2)</sup>		
VESDCDM	Electrostatic handling Charged Device Model (CDM)	X+/BR, Y+/TR, X-/TL, Y-/BL, VDD, MVDD	+/-1		kV
		Other pins	+/-1		
VESDMM	Electrostatic handling Machine Model (MM)	X+/BR, Y+/TR, X-/TL, Y-/BL, VDD, MVDD	+/-250		V
		Other pins	+/-250		
VESDCD	Electrostatic handling Contact Discharge (CD)	X+/BR, Y+/TR, X-/TL, Y-/BL, VDD, MVDD	+/-15		kV
TAMB	Operating ambient temperature		-40	+85	°C
TJUN	Operating junction temperature		-40	+125	°C
TSTOR	Storage temperature		-55	+150	°C
ILAT	Latch-up current <sup>(3)</sup>		+/-100		mA

(1) Tested to TLP (10A)

(2) Tested to JEDEC standard JESD22-A114

(3) Tested to JEDEC standard JESD78

Table 2 - Absolute Maximum Ratings

**2.2 Thermal Characteristics**

Symbol	Description	Conditions	Min	Max	Unit
θJAQ	Thermal Resistance Junction – Ambient QFN package	-	-	30.5	°C/W
θJAW	Thermal Resistance Junction – Ambient WLCSP package	-	-	29	°C/W

Table 3 – Thermal Characteristics

**2.3 Electrical Specifications**

Table below applies to full supply voltage and temperature range, unless otherwise specified. Typical values are given for T<sub>A</sub> = +25°C, VDD=VDDM=3.3V.

Symbol	Description	Conditions	Min	Typ.	Max	Unit
<b>Supply</b>						
VDD	Main supply voltage	-	2.3	-	3.6	V
IDD	Main supply current	OFF (MAN mode, no command, HAPT OFF)	-	0.4	0.75	µA
		WAIT (PENDET/TRG mode, pen up, PROX OFF, HAPT OFF)	-	1.7	-	
		TOUCH1 (PENTRG mode, pen down, X+Y, RATE=4kcps, Nfilt=1, POWDLY=0.5µs, touchscreen current excluded, HAPT OFF, VDD=2.3V)	-	30	-	
		TOUCH2 (PENTRG mode, pen down, X+Y, RATE=3kcps, Nfilt=7, POWDLY=0.5µs, touchscreen current excluded, HAPT OFF)	-	120	160	

**ADVANCED COMMUNICATIONS & SENSING**

Symbol	Description	Conditions	Min	Typ.	Max	Unit
		PROX (PENDET/TRG mode, pen up, TOUCHRATE=80cps, PROX ON, SCANPERIOD=200ms, HIGHIM=ON, SENSITIVITY=Max, FREQ=150kHz, BOOST=OFF, HAPT OFF)	-	8	20	
		HAPT (MAN mode, no command, LRA-PWM mode, MIN= 44.8kHz/50%, GAIN = Max, BW = 100, MOUTP/N floating, Squelch=011)	-	115	145	
MVDD	Haptics supply voltage	-	VDD	-	3.6	V
		OFF	-	0.01	1	μA
MIDD	Haptics supply current	SQUELCH (LRA-PWM mode, MIN= 44.8kHz/50%, GAIN = Max, BW = 100, MOUTP/N floating, Squelch=011)	-	6	10	μA
<b>Digital I/Os (ADDR, SCL, SDA, NRST, NIRQ, AUX1, AUX2, AUX3, MIN)</b>						
VIH	High level input voltage	SCL, SDA, NRST	0.8*VDD	-	3.6	V
		Other pins	0.8*VDD	-	VDD+0.2	
VIL	Low level input voltage	-	-0.3	-	0.8	V
ILEAK	Input leakage current	-	-1	-	1	μA
CI	Input capacitance	-	-	5	-	pF
VOH	High level output voltage	IOH = 4mA	0.8*VDD	-	-	V
VOL	Low level output voltage	IOL = 4mA	-	-	0.4	V
VPULL	External pull-up voltage	SCL, SDA, NRST, NIRQ	-	-	3.6	V
<b>Haptics Interface</b>						
IDRV	Maximum drive current (MOUTP/MOUTN)	MVDD = 3.6V	-	250	-	mA
VOFF	Output squelch differential error (from 0V ideal)	LRA or ERM, PWM or I2C, AmplitudeCode within squelch range, GAIN = Max, BW = 100, MOUTP/N floating, Squelch=011	0 <sup>(1)</sup>	0	0 <sup>(1)</sup>	mV
VERR	Output differential error (from 1.135V ideal)	LRA or ERM, I2C, AmplitudeCode = +127 (Max) GAIN = Min, BW = 100, MOUTP/N floating	125 <sup>(2)</sup>	0	125 <sup>(2)</sup>	mV
VDRV	Drive voltage (MOUTP/MOUTN)	-	-	-	VDDM	V
VDROP	Drop voltage (MOUTP/MOUTN)	From MVDD/MGND, @250mA	-	-	150	mV
ISHORT	Short-circuit detection current	Measured @MIDD	-	300	-	mA
FMINC	Motor input (MIN) frequency in I2C mode	40-60% duty cycle	-	-	50	MHz
FMINP	Motor input (MIN) frequency in PWM mode	HAPTRANGE = 0	12.8	-	25.6	kHz
		HAPTRANGE = 1	25.6	-	51.2	kHz
DCMIN	Motor input (MIN) duty cycle in PWM mode		2	-	98	%
TWRNG	Warning temperature	Junction temperature	-	120	-	°C
TALRM	Alarm temperature		-	155	-	
<b>Touchscreen Interface</b>						
ARES	ADC resolution		12	-	-	bits
AOFF	ADC offset		-	± 1	-	
AGE	ADC gain error	At full scale	-	0.5	-	LSB
ADNL	ADC differential non-linearity		-	± 1	-	
AINL	ADC integral non-linearity		-	± 1.5	-	
RBIAS	Biasing resistance		-	5	-	Ω
<b>Proximity Sensing Interface</b>						
CDC	External capacitance to be compensated	-	-	-	300	pF
t <sub>PROX</sub>	Scan period (reaction time)	Programmable	-	200	-	ms

**ADVANCED COMMUNICATIONS & SENSING**

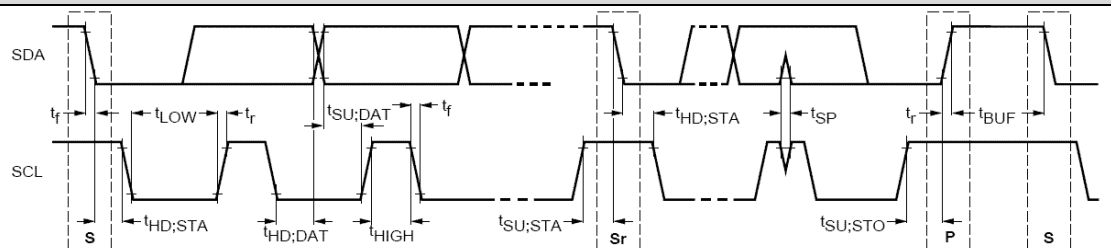
Symbol	Description	Conditions	Min	Typ.	Max	Unit
<b>Reset</b>						
V <sub>POR</sub>	Power-On-Reset voltage	Cf. §10	-	1.3	-	V
t <sub>RESET</sub>	Reset time after POR	Cf. §10	-	-	1	ms
t <sub>PULSE</sub>	Reset pulse from host uC	Cf. §10	1	-	-	us
<b>I2C Interface</b>						
 <p>The diagram shows the timing relationship between the Serial Data Line (SDA) and the Serial Clock Line (SCL). It illustrates a sequence of START (s), repeated START (Sr), STOP (P), and STOP (s) conditions. Key timing parameters are labeled: t<sub>HD;STA</sub> (hold time for repeated START), t<sub>LOW</sub> (LOW period of SCL), t<sub>HIGH</sub> (HIGH period of SCL), t<sub>SU;STA</sub> (set-up time for repeated START), t<sub>HD;DAT</sub> (data hold time), t<sub>SU;DAT</sub> (data set-up time), t<sub>r</sub> (rise time of both SDA and SCL), t<sub>f</sub> (fall time of both SDA and SCL), t<sub>SU;STO</sub> (set-up time for STOP), t<sub>BUF</sub> (bus free time between STOP and START), and t<sub>SP</sub> (pulse width of spikes suppressed by the input filter).</p>						
f <sub>SCL</sub>	SCL clock frequency	-	-	-	400	kHz
t <sub>HD;STA</sub>	Hold time (repeated) START condition	-	0.6	-	-	μs
t <sub>LOW</sub>	LOW period of the SCL clock	-	1.3	-	-	μs
t <sub>HIGH</sub>	HIGH period of the SCL clock	-	0.6	-	-	μs
t <sub>SU;STA</sub>	Set-up time for a repeated START condition	-	0.6	-	-	μs
t <sub>HD;DAT</sub>	Data hold time	-	0	-	-	μs
t <sub>SU;DAT</sub>	Data set-up time	-	100	-	-	ns
t <sub>r</sub>	Rise time of both SDA and SCL	-	20+0.1C <sub>b</sub>	-	300	ns
t <sub>f</sub>	Fall time of both SDA and SCL	-	20+0.1C <sub>b</sub>	-	300	ns
t <sub>SU;STO</sub>	Set-up time for STOP condition	-	0.6	-	-	μs
t <sub>BUF</sub>	Bus free time between a STOP and START condition	-	1.3	-	-	μs
C <sub>b</sub>	Capacitive load for each bus line	-	-	-	400	pF
t <sub>SP</sub>	Pulse width of spikes suppressed by the input filter	Up to 0.3xVDD from GND, down to 0.7xVDD from VDD	50	-	-	ns
<b>Miscellaneous</b>						
FOSCL	Low frequency internal oscillator	-	-	32	-	kHz
FOSCH	High frequency internal oscillator	-	-	1.8	-	MHz

<sup>(1)</sup> Guaranteed by design.

<sup>(2)</sup> PWM mode can introduce an additional error of 2.5% of full scale.

Table 4 – Electrical Specifications

**3 TYPICAL OPERATING CHARACTERISTICS**

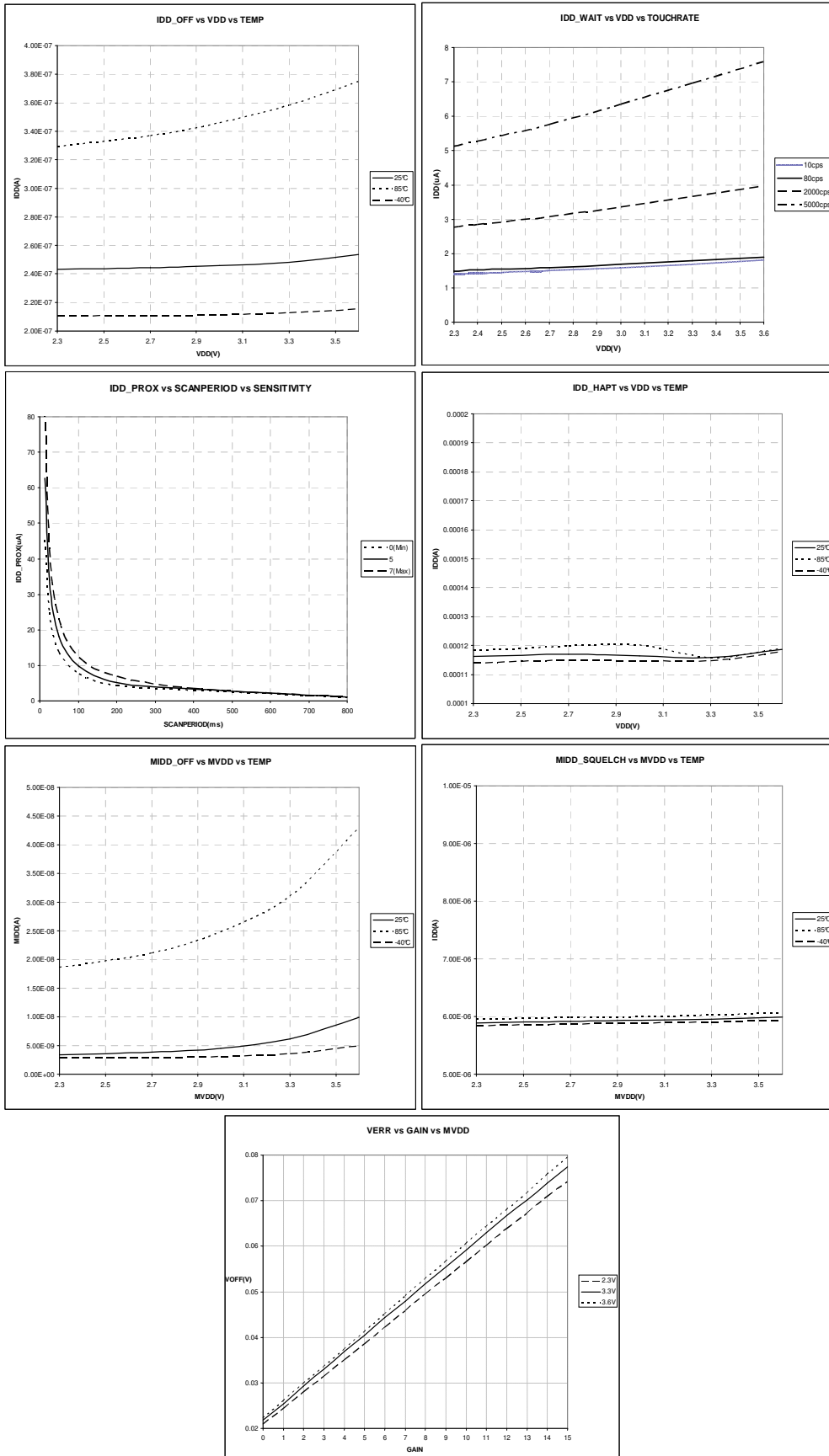
 Conditions as defined in §2.3,  $T_A = +25^\circ\text{C}$ ,  $V_{DD} = V_{DDM} = 3.3\text{V}$  unless otherwise specified.

**ADVANCED COMMUNICATIONS & SENSING**
**4 TOUCHSCREEN INTERFACE**
**4.1 Introduction**

The purpose of the touchscreen interface is to measure and extract touch information like coordinates and pressure. This is done in two steps, first an ADC measures the analog signal coming from the screen, and then digital processing is performed to consolidate the data.

As illustrated below the chip's touchscreen interface is compatible with both 4-wire and 5-wire touchscreens. Touchscreen type is defined by parameter TSTYPE.

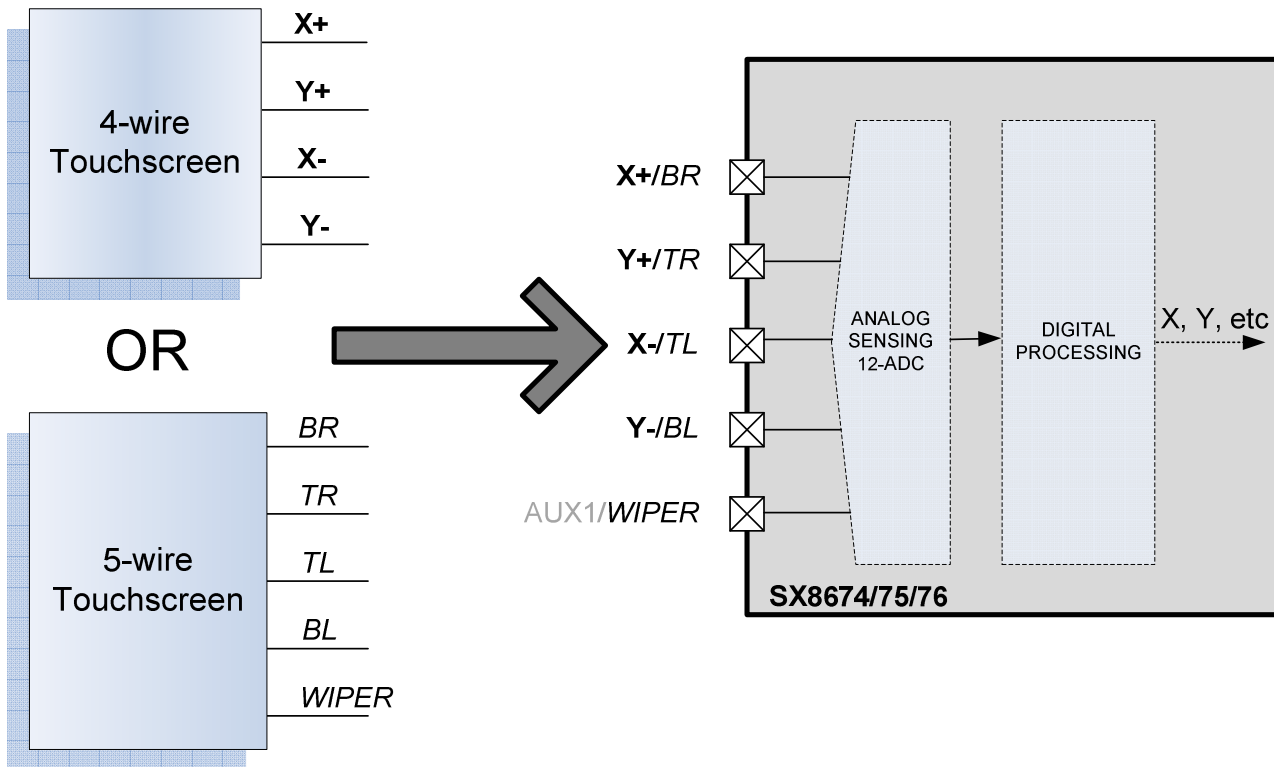

Figure 9 – Touchscreen Interface Overview

A 4-wire resistive touch screen consists in two (resistive) conductive sheets separated by an insulator when not pressed. Each sheet is connected through 2 electrodes at the border of the sheet. When a pressure is applied on the top sheet, a connection with the lower sheet is established.

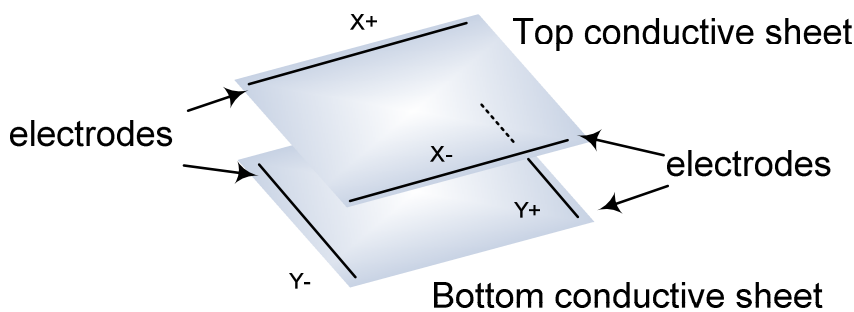

Figure 10 – 4-wire Touchscreen

A 5-wire resistive touch screen consists in two (resistive) conductive sheets separated by an insulator when not pressed. 4 electrodes are connected on the 4 corners of the bottom conductive sheet. They are referred as Top Left (TL), Top Right (TR), Bottom Left (BL) and Bottom Right (BR).

The fifth wire (WIPER) is used for sensing the top sheet voltage. When a pressure is applied on the top sheet, a connection with the lower sheet is established.

Higher reliability and better endurance are the advantages of 5-wire touchscreens but they do not allow pressure measurement

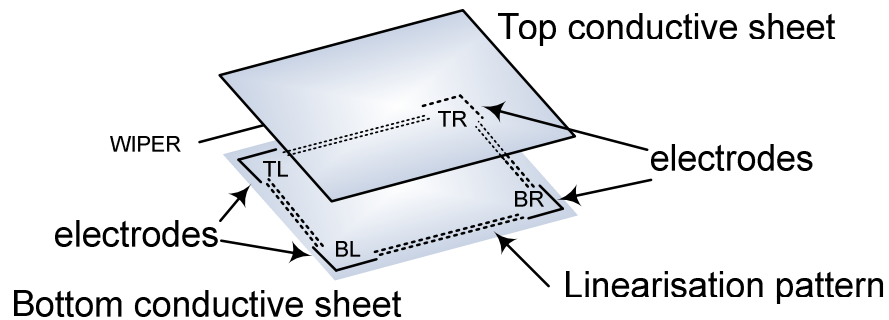

Figure 11 – 5-wire Touchscreen

## 4.2 Coordinates Measurement

### 4.2.1 4-wire Touchscreen

The electrode plates are internally connected through terminals X+, X- and Y+, Y- to an analog to digital converter (ADC) and a reference voltage (Vref). The resistance between the terminals X+ and X- is defined by Rxtot. Rxtot will be split in 2 resistors, R1 and R2, in case the screen is touched. Similarly, the resistance between the terminals Y+ and Y- is represented by R3 and R4. The connection between the top and bottom sheet is represented by the touch resistance (RT).

In order to measure the Y coordinate, the top resistive sheet (Y) is biased with a voltage source (Vref). Resistors R3 and R4 determine a voltage divider proportional to the Y position of the contact point. Since the converter has a high input impedance, no current flows through R1 (and RT) so that the voltage X+ at the converter input is given by the voltage divider created by R3 and R4.

The X coordinate is measured in a similar fashion with the bottom resistive sheet (X) biased to create a voltage divider by R1 and R2, while the voltage on the top sheet is measured through R3.

The resistance RT is the resistance obtained when a pressure is applied on the screen. RT is created by the contact area of the X and Y resistive sheet and varies with the applied pressure.

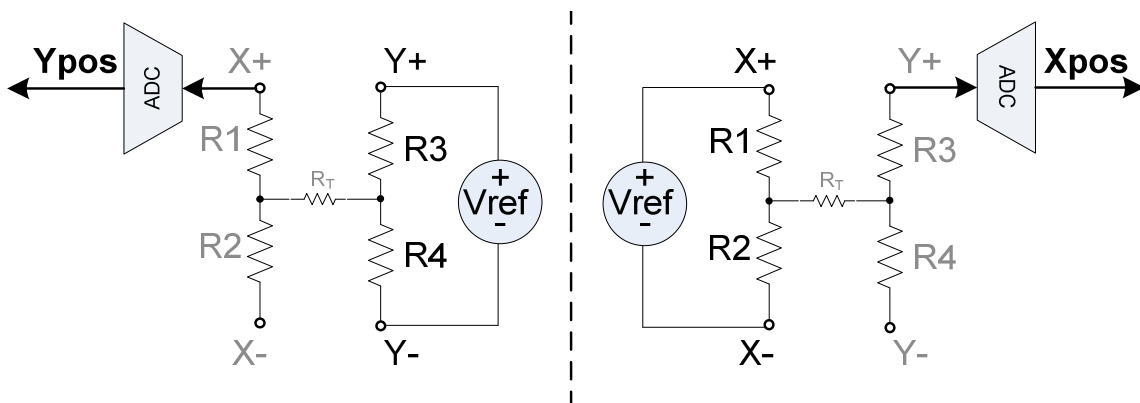

Figure 12 – 4-wire Touchscreen Coordinates Measurement

The X and Y positions output by the ADC correspond to the formulas below:

$$X_{pos} = 4095 \cdot \frac{R2}{R1 + R2} \quad Y_{pos} = 4095 \cdot \frac{R4}{R3 + R4}$$

4095 corresponds to the max output value of the ADC (12 bits =>  $2^{12} - 1$ ).

For example, a touch in the center of the screen will output  $(X_{pos}, Y_{pos}) = \sim(2048, 2048)$

**ADVANCED COMMUNICATIONS & SENSING**
**4.2.2 5-wire Touchscreen**

5-wire touchscreen coordinates measurement is performed similarly by biasing opposite corner pairs in either X or Y directions on the lower panel, and converting the voltage appearing on the wiper panel with the ADC.

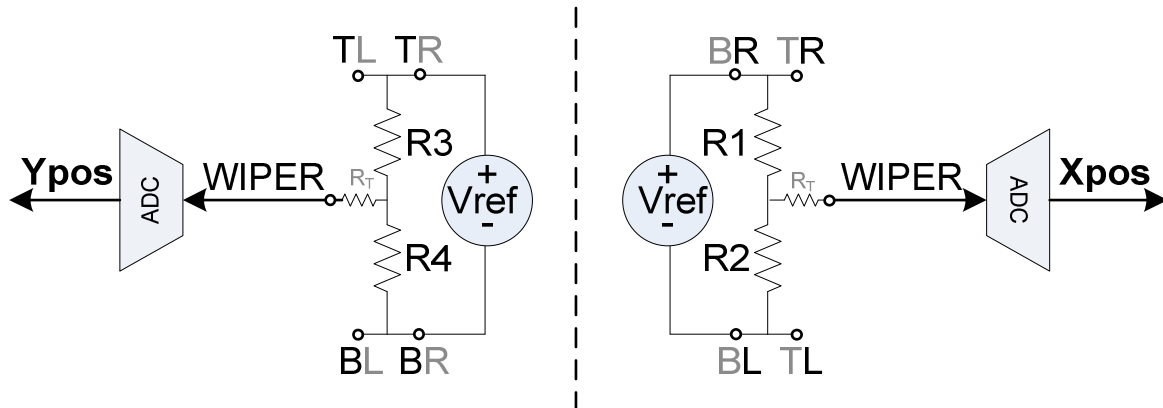

Figure 13 – 5-wire Touchscreen Coordinates Measurement

The X and Y positions output by the ADC correspond to the formulas below:

$$X_{pos} = 4095 \cdot \frac{R_2}{R_1 + R_2} \quad Y_{pos} = 4095 \cdot \frac{R_4}{R_3 + R_4}$$

4095 corresponds to the max output value of the ADC (12 bits =>  $2^{12} - 1$ ).

For example, a touch in the center of the screen will output  $(X_{pos}, Y_{pos}) = \sim(2048, 2048)$

**4.3 Pressure Measurement (4-wire only)**

The pressure measurement consists in extracting the touch resistance  $R_T$  via two additional setups  $z_1$  and  $z_2$  illustrated below. The smaller  $R_T$ , the more common touched surface there is between top and bottom plates and hence the more “pressure” there is by the user.

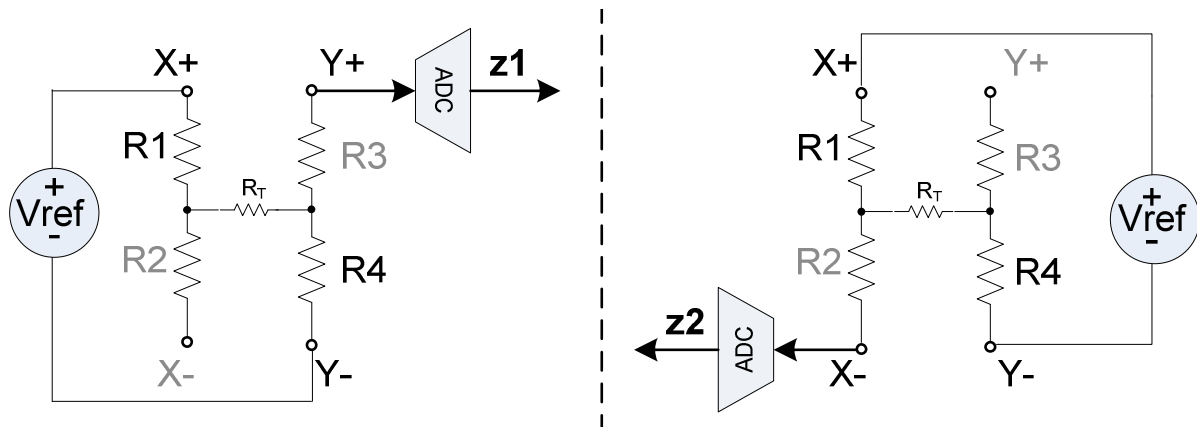

Figure 14 – Pressure Measurement

The  $z_1$  and  $z_2$  values output by the ADC correspond to the formulas below:

$$z_1 = 4095 \cdot \frac{R_4}{R_1 + R_4 + R_T} \quad z_2 = 4095 \cdot \frac{R_4 + R_T}{R_1 + R_4 + R_T}$$

The X and Y total sheet resistance ( $R_{xtot} = R_1 + R_2$ ,  $R_{ytot} = R_3 + R_4$ ) are known from the touch screen supplier.

$R_4$  is proportional to the Y coordinate and its value is given by the total Y plate resistance  $R_{ytot}$  multiplied by the fraction of the Y position over the full coordinate range.



**ADVANCED COMMUNICATIONS & SENSING**

$$R_{xtot} = R1 + R2$$

$$R_{ytot} = R3 + R4$$

$$R4 = R_{ytot} \cdot \frac{Y_{pos}}{4095}$$

Re-arranging z1 and z2 gives:

$$R_T = R4 \cdot \left[ \frac{z2}{z1} - 1 \right]$$

This finally results in:

$$R_T = R_{ytot} \cdot \frac{Y_{pos}}{4095} \cdot \left[ \frac{z2}{z1} - 1 \right]$$

The touch resistance calculation above hence requires three channel measurements ( $Y_{pos}$ ,  $z2$  and  $z1$ ) and one specification data ( $R_{ytot}$ ).

An alternative calculation method is using  $X_{pos}$ ,  $Y_{pos}$ , one  $z$  channel and both  $R_{xtot}$  and  $R_{ytot}$  as shown in the next calculations.

$R1$  is inversely proportional to the  $X$  coordinate:

$$R1 = R_{xtot} \cdot \left[ 1 - \frac{X_{pos}}{4095} \right]$$

Substituting  $R1$  and  $R4$  into  $z1$  and rearranging terms gives:

$$R_T = \frac{R_{ytot} \cdot Y_{pos}}{4095} \cdot \left[ \frac{4095}{z1} - 1 \right] - R_{xtot} \cdot \left[ 1 - \frac{X_{pos}}{4095} \right]$$

Please note that the chip only outputs  $z1$ ,  $z2$ , etc. The calculation of  $R_T$  itself with the formulas above must be performed by the host.

#### 4.3.1 Bias Time (POWDLY)

In order to perform correct measurements, some time must be given for the touch screen to reach a proper  $V_{ref}$  bias level before the conversion is actually performed. It is a function of the PCB trace resistance connecting the chip to the touchscreen and also the capacitance of the touchscreen. If  $\tau$  is this RC time constant, then POWDLY duration must be programmed to  $10\tau$  to reach 12 bits accuracy.

Adding a capacitor from the touch screen electrodes to ground may also be used to minimize external noise (if the touchscreen is used as the proximity sensor, make sure you do not exceed the maximum capacitive load for required for proper proximity sensing operation). The low-pass filter created with the capacitor may increase settling time requirement. Therefore, POWDLY can be used to stretch the acquisition period and delay conversion appropriately.

POWDLY can be estimated by the following formula:

$$PowDly = 10 \times R_{touch} \times C_{touch}$$

#### 4.4 Pen Detection

The pen detection circuitry is used both to detect a user action and generate an interrupt or start an acquisition in PENDET and PENTRG mode respectively. Doing pen detection prior to conversion avoids feeding the host with dummy data and saves power. Pen detection is also used to disable and resume proximity sensing. For more details on pen detection usage please refer to §4.7.

A 4-wire touchscreen will be powered between  $X+$  and  $Y-$  through a resistor  $RPNDT$  so no current will flow as long as no pressure is applied to the surface (see figure below). When a touch occurs, a current path is created bringing  $X+$  to the level defined by the resistive divider determined by  $RPNDT$  and the sum of  $R1$ ,  $R_T$  and  $R4$ .

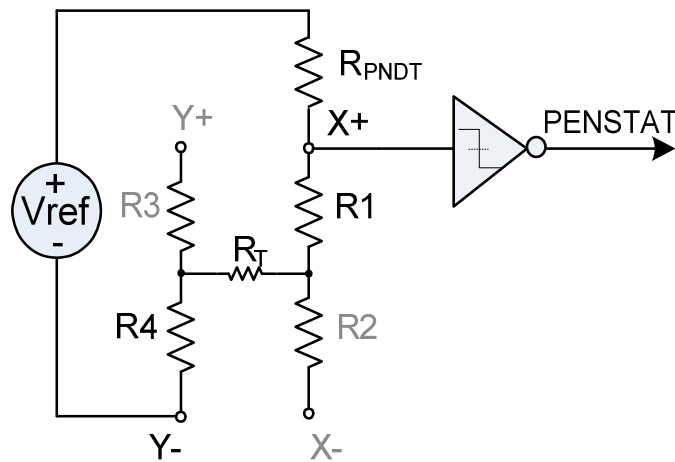

Figure 15 – 4-wire Touchscreen Pen Detection

When using a 5-wire touchscreen, the pen detection pull-up resistor  $R_{PNDT}$  and digital comparator continue to monitor the X+/BR pin as in 4-wire mode. The top panel is grounded via the WIPER pin to provide the grounding path for a screen touch event. When a touch occurs, a current path is created and will bring BR to the level defined by the resistive divider determined by  $R_{PNDT}$  and the sum of  $R_1$ ,  $R_T$  and  $R_W$ .

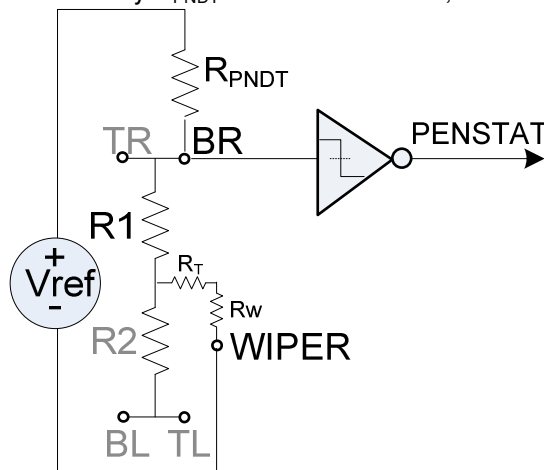

Figure 16 – 5-wire Touchscreen Pen Detection

$R_{PNDT}$  can be configured to 4 different values to accommodate different screen resistive values.  $R_{PNDT}$  should be set to a value greater than  $7 \times (R_{xtot} + R_{ytot})$ , it is recommended to set it to max value.

Pen detection uses a bias time of  $POWDLY/8$  (digital comparator => less precision required vs analog conversion). Increasing  $POWDLY$  can improve the detection on panels with high resistance.

A pen touch will set the PENSTAT bit of the RegStat register which will generate an interrupt if enabled in RegIrqMsk.

A pen release will reset PENSTAT bit of the RegStat register which will generate an interrupt if enabled in RegIrqMsk.

#### 4.5 Multitouch Measurement (4-wire only)

SX8674/75/76 support up to two simultaneous touches on any standard 4-wire touchscreen. The simplified model for dual-touch is given in figure below.

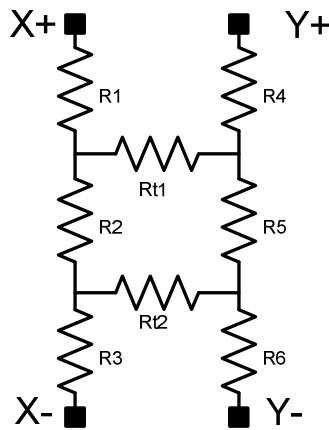

$$R_{xtot} = R1 + R2 + R3$$

$$R_{ytot} = R4 + R5 + R6$$

Figure 17 – Dual-touch Simplified Model

The two contacts create touch resistances  $R_{t1}$  and  $R_{t2}$  between the two layers of the touchscreen.

The SX8674/75/76 perform on-chip specific multitouch measurements which the host retrieves and processes with a specific software enabling the detection of the gestures described in §13.3.

For optimum gesture detection,  $R_{mSelX}$  and  $R_{mSelY}$  parameters should be set according to table below.

X/Y Panel Resistance ( $\Omega$ )	$R_{mSelX/Y}$
100-187	000
188-312	001
313-938	010
939-1875	011
1876-4375	100
4376-9375	101
9376-18780	110
>18780	111

Table 5 –  $R_{mSelX/Y}$  Selection Table

#### 4.6 Digital Processing

The chip offers 4 types of data processing which allows the user to make trade-offs between data throughput, power consumption and noise rejection.

The parameter  $FILT$  is used to select the filter order  $N_{filt}$ . The noise rejection will be improved with a high order to the detriment of power consumption. Each channel can be sampled up to 7 times and then processed to get a single consolidated coordinate.

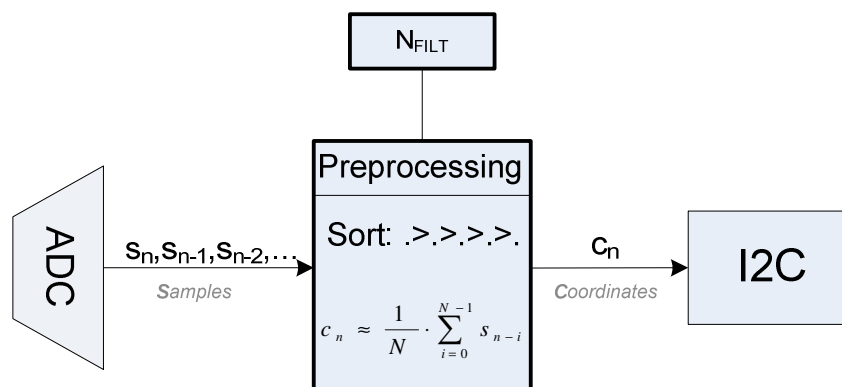

Figure 18 – Digital Processing Block Diagram

**ADVANCED COMMUNICATIONS & SENSING**

FILT	Nfilt	Function
0	1	$c_n = s_n$ No average.
1	3	$c_n = \frac{1}{3} \cdot \frac{4079}{4095} (s_n + s_{n-1} + s_{n-2})$ 3 ADC samples are averaged.
2	5	$c_n = \frac{1}{5} \cdot \frac{4079}{4095} (s_n + s_{n-1} + s_{n-2} + s_{n-3} + s_{n-4})$ 5 ADC samples are averaged.
3	7	$s_{\max 1} \geq s_{\max 2} \geq s_a \geq s_b \geq s_c \geq s_{\min 1} \geq s_{\min 2}$ $c_n = \frac{1}{3} \cdot \frac{4079}{4095} (s_a + s_b + s_c)$ 7 ADC samples are sorted and the 3 center samples are averaged.

Table 6 – Digital Processing Functions

The parameter SETDLY sets the settling time between the consecutive conversions of the same channel.

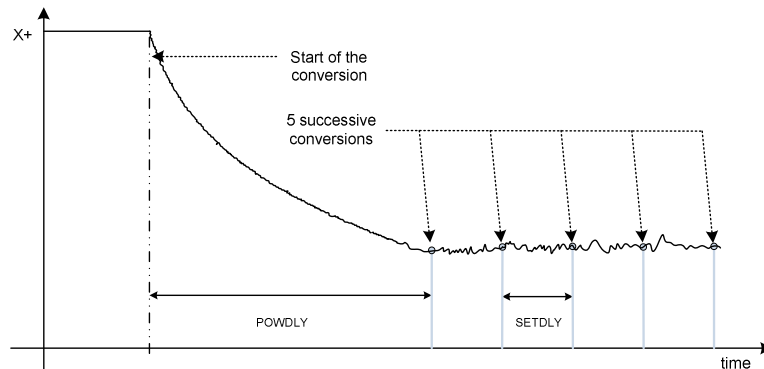

Figure 19 – POWDLY and SETDLY (FILT=2)

In most applications, SETDLY can be set to minimum (0.5us). However, in some particular applications where an accuracy of 1LSB is required SETDLY may need to be increased.

## 4.7 Host Operation

### 4.7.1 Overview

The chip has three operating modes that are configured using the I2C as defined in §11 :

- Manual (command 'MAN' and TOUCHRATE = 0).
- Pen detect (command 'PENDET' and TOUCHRATE > 0).
- Pen trigger (command 'PENTRG' and TOUCHRATE > 0).

At power-up the chip is set in manual mode.

### 4.7.2 Manual Mode (MAN)

In manual mode (MAN) the touchscreen interface is stopped and conversions must be manually triggered by the host using SELECT and CONVERT command.

**ADVANCED COMMUNICATIONS & SENSING**

When a command is received, the chip executes the associated tasks listed in table below and waits for the next command. It is up to the host to sequence all actions.

Pen detection is performed after each CONVERT command and if pen is not detected, no touch operation is performed. Following figures assume pen down. PENSTAT is not updated in MAN mode.

To enter MAN mode the host must send the MAN command and then set TOUCHRATE = 0.

Command	Actions
CONVERT(CHAN)	Select and bias CHAN Wait for the programmed settling time (POWDLY) Convert CHAN
SELECT(CHAN)	Select and bias CHAN

Table 7 – Manual Mode Commands

As illustrated in figure below the CONVERT command will bias the channel, wait for the programmed settling time (POWDLY), and run the conversion.

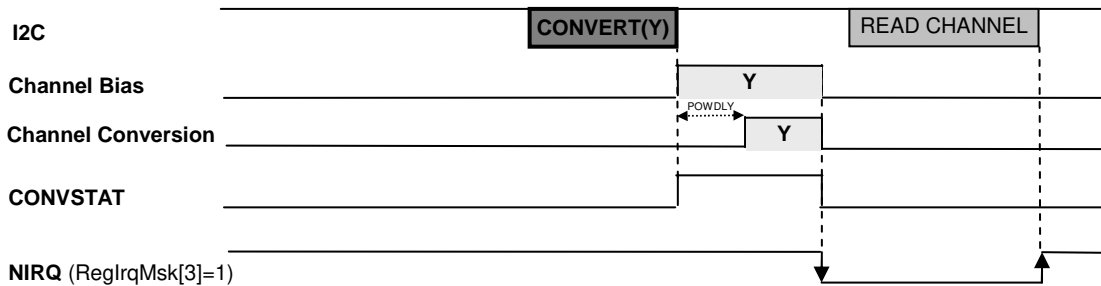

Figure 20 – Manual Mode – CONVERT Command (CHAN = Y; PROXSCANPERIOD = 0)

When the CONVERT command is used with CHAN=SEQ, multiple channels as defined in RegChnMsk are sampled. In this case, each channel will be sequentially biased during POWDLY before a conversion is started. At the end of each channel conversion the bias is automatically removed.

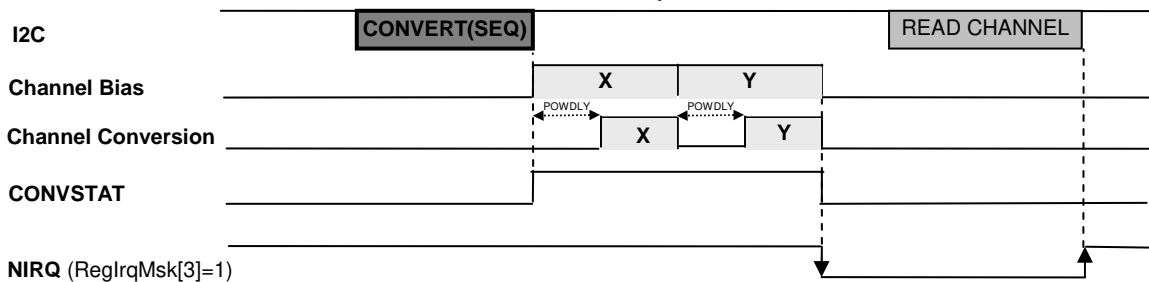
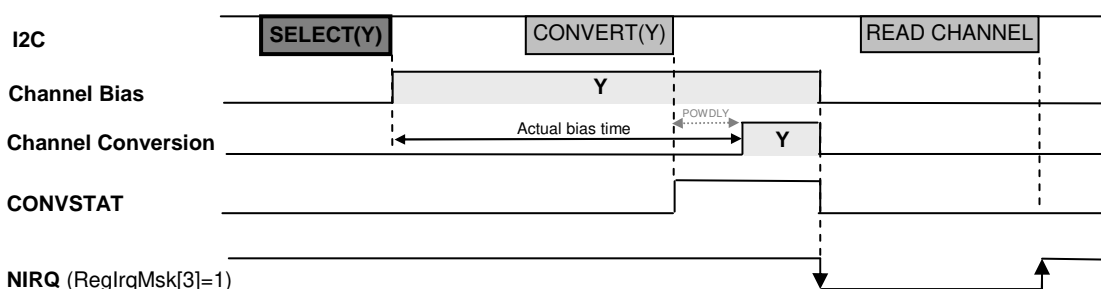

Figure 21 – Manual Mode – CONVERT Command (CHAN = SEQ = [X;Y]; PROXSCANPERIOD = 0)

In case the range of POWDLY settings available is not enough to cover the required settling time, one can use the SELECT command first to bias the channel, and then send the CONVERT command hence extending bias time. SELECT command cannot be used with CHAN=SEQ.



**ADVANCED COMMUNICATIONS & SENSING**
*Figure 22 – Manual Mode – SELECT command (CHAN = Y; PROXSCANPERIOD = 0)*

At the end of the conversion(s) bit CONVSTAT will be reset which will trigger NIRQ falling edge (if enabled in RegIrqMsk). Host can then read channel data which will release NIRQ.

Please note that when the SELECT command is used, the channel is converted whatever the pen status (no pen detection performed).

#### 4.7.3 Pen Detect Mode (PENDET)

In pen detect mode (PENDET) the chip will only run pen detection (continuously when pen is up, regularly as defined by TOUCHRATE when pen is down) and update PENSTAT bit in RegStat to be able to generate an interrupt (NIRQ) upon pen detection and/or release. No (touch) conversion is performed in this mode.

To enter PENDET mode the host must set TOUCHRATE > 0 and then send PENDET command. To quit PENDET mode and stop the touchscreen interface the host must enter MAN mode.

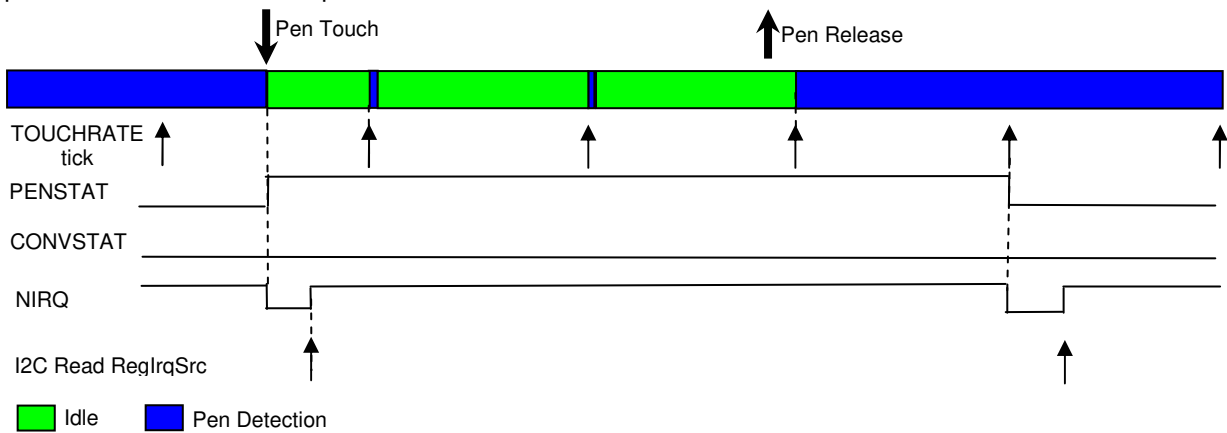
*Figure 23 – Pen Detect Mode (RegIrqMsk[3:2] = 11 ; PROXSCANPERIOD = 0)*

Please note that the next pen detection is not performed as long as NIRQ is low. If the host is too slow and doesn't read IrqSrc before next TOUCHRATE tick, no operation is performed and this TOUCHRATE tick is simply ignored until next one.

#### 4.7.4 Pen Trigger Mode (PENTRG)

In pen trigger mode (PENTRG) the chip will perform pen detection (continuously when pen is up, regularly as defined by TOUCHRATE when pen is down) and if pen is down, will be followed by a conversion as defined in RegChanMsk. The chip will update CONVSTAT bit in RegStat and will be able to generate an interrupt (NIRQ) upon conversion completion. The chip will also update PENSTAT bit in RegStat and will be able to generate an interrupt (NIRQ) upon pen detection and/or release.

The PENTRG mode offers the best compromise between power consumption and coordinate throughput. To enter PENTRG mode the host must set TOUCHRATE > 0 and then send PENTRG command. To quit PENTRG mode and stop the touchscreen interface the host must enter MAN mode.

**ADVANCED COMMUNICATIONS & SENSING**

Figure 24 – Pen Trigger Mode ( $RegIrqMsk[3:2] = 10$  ;  $PROXSCANPERIOD = 0$ )

Please note that to prevent data loss, the next pen detection and conversion are not performed as long as all current channel data (i.e. channels selected in  $RegChanMsk$ ) have not been read. If the host is too slow and doesn't read all channel data before next TOUCHRATE tick, no operation is performed and this TOUCHRATE tick is simply ignored until next one.

#### 4.7.5 Maximum Throughput vs. TOUCHRATE setting

In PENTRG mode the TOUCHRATE parameter is used to define the required coordinate's throughput/rate. However, as previously mentioned, in order for a new conversion to be performed the current conversion must be completed and all relevant channel data must have been read by the host. If this condition is not met when the next TOUCHRATE tick occurs, the tick is ignored and the condition checked again at the next one. This will result in reduced actual rate vs what has been programmed in the TOUCHRATE parameter.

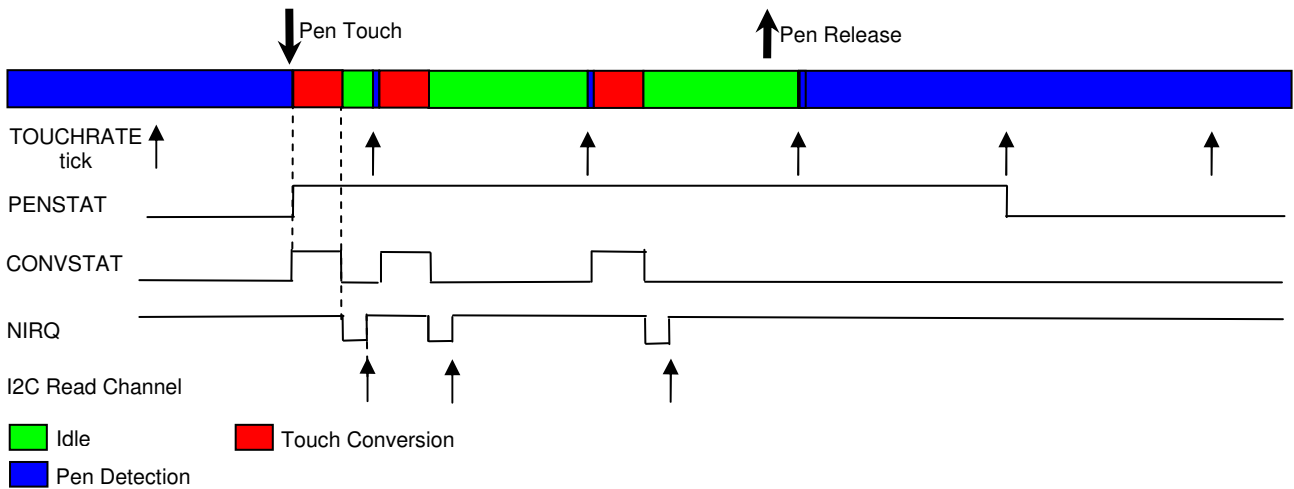
This is illustrated in figures below.

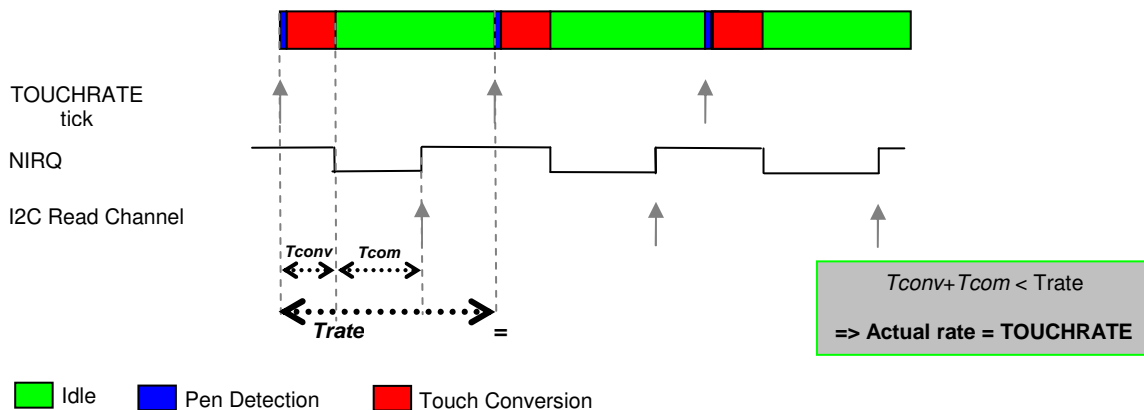

Figure 25 – Correct TOUCHRATE setting

**ADVANCED COMMUNICATIONS & SENSING**

Figure 26 – Incorrect (too high) TOUCHRATE setting

In order to prevent this, one can estimate the maximum throughput achievable and set TOUCHRATE parameter accordingly.

$$\text{MaxThroughput} = 1 / (T_{conv} + T_{com})$$

$T_{com}$  is the time between the end of conversion (ie NIRQ falling edge) and the end of channel data reading (i.e. NIRQ rising edge). Maximum throughput implies that the host reacts “instantaneously” to NIRQ falling edge:

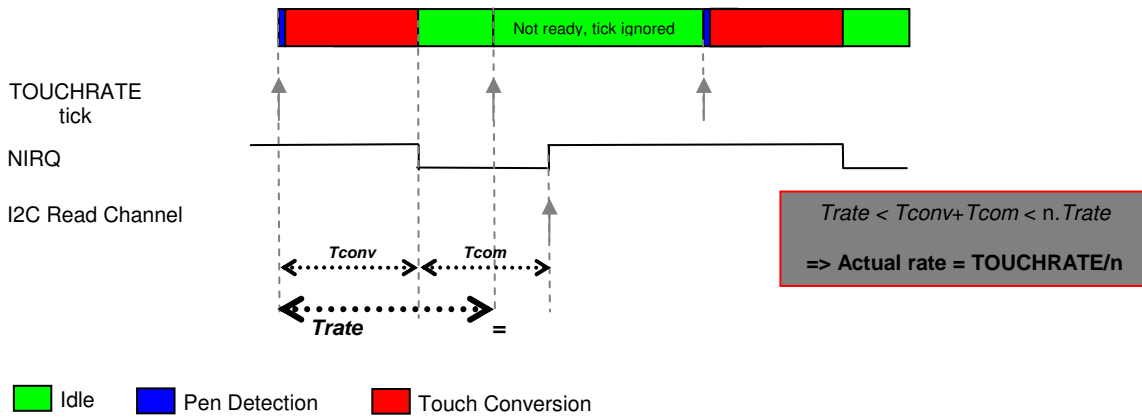
$$T_{com} \approx (8 + 16 \times N_{chan}) \times T_{I2C}$$

$T_{conv}$  is the total conversion time:

$$T_{conv}(us) = 47 \cdot T_{osc} + N_{chan} \cdot (POWDLY + (N_{filt} - 1) \cdot SETDLY + (21N_{filt} + 1) \cdot T_{osc})$$

- $T_{I2C}$  is the period of the I2C clock SCL
- $N_{filt} = \{1,3,5,7\}$  based on the order defined for the filter FILT
- $N_{chan} = \{1,2,3,4,5\}$  based on the number of channels defined in RegChanMsk
- POWDLY = 0.5us to 18.19ms, settling time as defined in RegTS0
- SETDLY = 0.5us to 18.19ms, settling time when filtering as defined in RegTS2
- $T_{osc}$  is the period of the internal oscillator FOSCH

Some examples of maximum throughputs achievable with an I2C running at 400kHz are given below.

Nchan	Nfilt	POWDLY [us]	SETDLY [us]	Tconv [us]	Tcom [us]	Total [us]	CR [kcps]	ECR [kcps]	SR [ksps]	ESR [ksps]
2	1	0.5	0.5	51.7	100	151.7	<b>6.6</b>	13.2	6.6	13.2
2	3	35.5	0.5	170.6	100	270.6	<b>3.7</b>	7.4	11.1	22.2
2	5	2.2	0.5	152.8	100	252.8	<b>4</b>	8	20	40
4	3	35.5	0.5	315.0	200	515	<b>1.9</b>	7.6	5.7	22.8

Table 8 – Maximum Throughputs Examples

- CR = Coordinate Rate
- ECR = Equivalent Coordinate Rate = CR x  $N_{chan}$
- SR = Sampling Rate = CR x  $N_{filt}$
- ESR = Equivalent Sampling Rate = SR x  $N_{chan} = CR \times N_{filt} \times N_{chan}$

For proper operation, the TOUCHRATE parameter should not exceed the theoretical maximum throughput CR.



**5 PROXIMITY SENSING INTERFACE (SX8674/76)**
**5.1 Introduction**

The purpose of the proximity sensing interface is to detect when a conductive object (usually a body part i.e. finger, palm, face, etc) is in the proximity of the system. This is commonly used in power-sensitive mobile applications to turn the screen's LCD ON/OFF depending on user's finger/palm/face proximity.

The chip's proximity sensing interface is based on capacitive sensing technology and shares the ADC with the touchscreen interface (Cf §5.4.2). An overview is given in figure below.

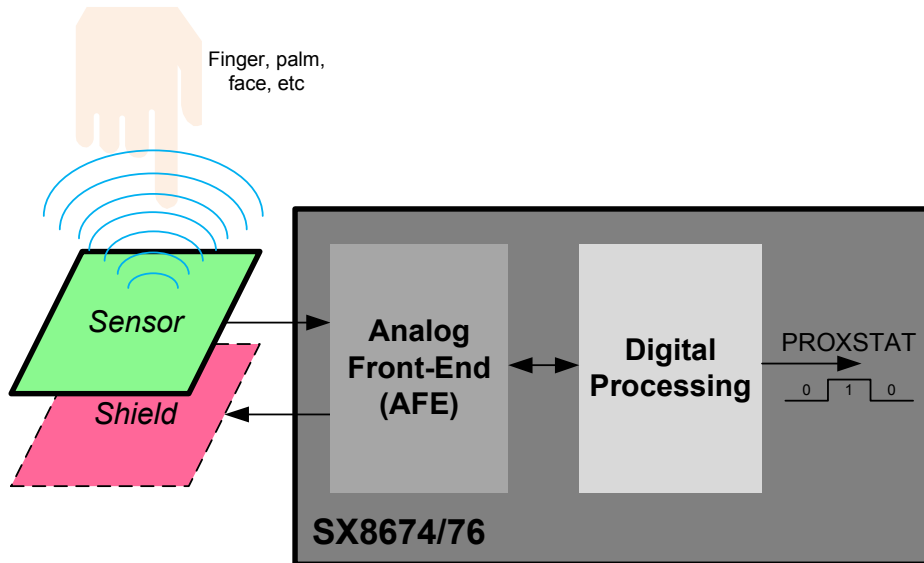

Figure 27 – Proximity Sensing Interface Overview

- ❖ The sensor can be the top layer of the touchscreen or a simple copper area on the PCB (programmable in PROXSENSORCON). Its capacitance (to ground) will vary when a conductive object is moving in its proximity.
- ❖ The optional shield can be the bottom layer of the touchscreen or a simple copper area on the PCB (programmable in PROXSHIELDCON) below/under/around the sensor. It is used to protect the sensor against potential surrounding noise sources and improve its global performance. It also brings directivity to the sensing, for example sensing objects approaching from top only.
- ❖ The analog front-end (AFE) performs the raw sensor's capacitance measurement and converts it into a 12 bit digital code. It also controls the shield. See §5.2 for more details.
- ❖ The digital processing block computes the raw capacitance measurement from the AFE and extracts a binary information PROXSTAT corresponding to the proximity status, i.e. object is "Far" or "Close". It also triggers AFE operations (compensation, etc). See §5.3 for more details.

To save power since the proximity event is slow by nature, the block will be waken-up regularly at every programmed scan period (PROXSCANPERIOD) to sense and then process a new proximity sample. The block will be in idle mode most of the time. This is illustrated in figure below

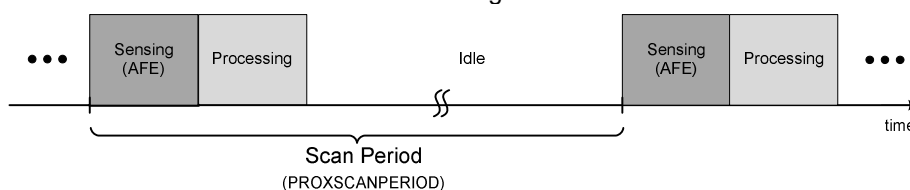

Figure 28 – Proximity Sensing Sequencing

**ADVANCED COMMUNICATIONS & SENSING**
**5.2 Analog Front-End (AFE)**
**5.2.1 Capacitive Sensing Basics**

Capacitive sensing is the art of measuring a small variation of capacitance in a noisy environment. As mentioned above, the chip's proximity sensing interface is based on capacitive sensing technology. In order to illustrate some of the user choices and compromises required when using this technology it is useful to understand its basic principles.

To illustrate the principle of capacitive sensing we will use the simplest implementation where the sensor is a copper plate on a PCB but the exact same principles apply if the sensor is the touchscreen's top plate.

The figure below shows a cross-section and top view of a typical capacitive sensing implementation. The sensor connected to the chip is a simple copper area on top layer of the PCB. It is usually surrounded (shielded) by ground for noise immunity (shield function) but also indirectly couples via the grounds areas of the rest of the system (PCB ground traces/planes, housing, etc). For obvious reasons (design, isolation, robustness ...) the sensor is stacked behind an overlay which is usually integrated in the housing of the complete system. When the touchscreen is used for sensing the overlay corresponds to the thin and flexible protection film covering the top panel.

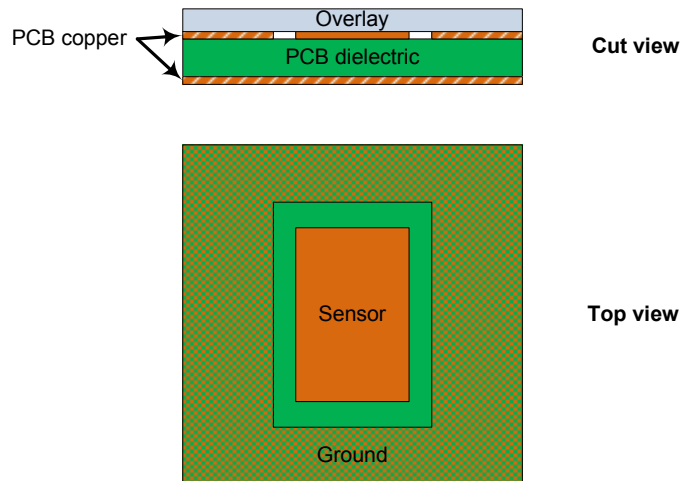

Figure 29 – Typical Capacitive Sensing Implementation

When the conductive object to be detected (finger/palm/face, etc) is not present, the sensor only sees an inherent capacitance value  $C_{Env}$  created by its electrical field's interaction with the environment, in particular with ground areas.

When the conductive object (finger/palm/face, etc) approaches, the electrical field around the sensor will be modified and the total capacitance seen by the sensor increased by the user capacitance  $C_{User}$ . This phenomenon is illustrated in the figure below.

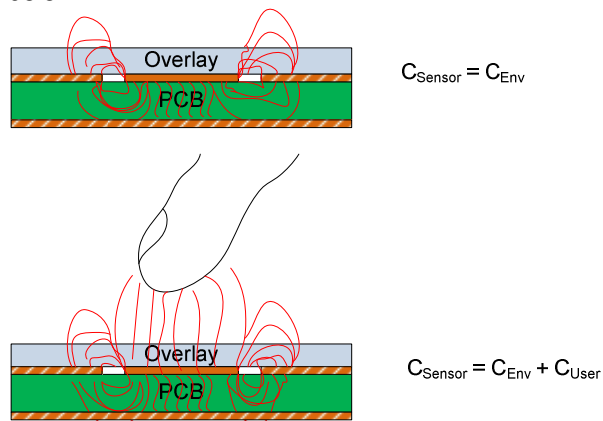

Figure 30 – Proximity Effect on Electrical Field and Sensor Capacitance