



Chipsmall Limited consists of a professional team with an average of over 10 year of expertise in the distribution of electronic components. Based in Hongkong, we have already established firm and mutual-benefit business relationships with customers from,Europe,America and south Asia,supplying obsolete and hard-to-find components to meet their specific needs.

With the principle of “Quality Parts,Customers Priority,Honest Operation,and Considerate Service”,our business mainly focus on the distribution of electronic components. Line cards we deal with include Microchip,ALPS,ROHM,Xilinx,Pulse,ON,Everlight and Freescale. Main products comprise IC,Modules,Potentiometer,IC Socket,Relay,Connector.Our parts cover such applications as commercial,industrial, and automotives areas.

We are looking forward to setting up business relationship with you and hope to provide you with the best service and solution. Let us make a better world for our industry!



## Contact us

Tel: +86-755-8981 8866 Fax: +86-755-8427 6832

Email & Skype: info@chipsmall.com Web: www.chipsmall.com

Address: A1208, Overseas Decoration Building, #122 Zhenhua RD., Futian, Shenzhen, China



## DESCRIPTION

The SX8724S is a data acquisition system based on Semtech's low power ZoomingADC™ technology. It directly connects most types of miniature sensors with a general purpose microcontroller.

With 3 differential inputs, it can adapt to multiple sensor systems. Its digital outputs are used to bias or reset the sensing elements.

## APPLICATIONS

- Industrial pressure sensing
- Industrial temperature sensing
- Industrial chemical sensing
- Barometer
- Compass

## FEATURES

- Up to 16-bit differential data acquisition
- Programmable gain: (1/12 to 1000)
- Sensor offset compensation up to 15 times full scale of input signal
- 3 differential or 6 single-ended signal inputs
- Programmable Resolution versus Speed versus Supply current
- Digital outputs to bias Sensors
- Internal or external voltage reference
- Internal time base
- Low-power (250 uA for 16b @ 250 S/s)
- SPI interface, 2 Mbps serial clock

## ORDERING INFORMATION

DEVICE	PACKAGE	REEL QUANTITY
SX8724SWLTDT	MLPQ-W-16 4x4	1000

- Available in tape and reel only
- WEEE/RoHS compliant, Pb-Free and Halogen Free.

## FUNCTIONAL BLOC DIAGRAM

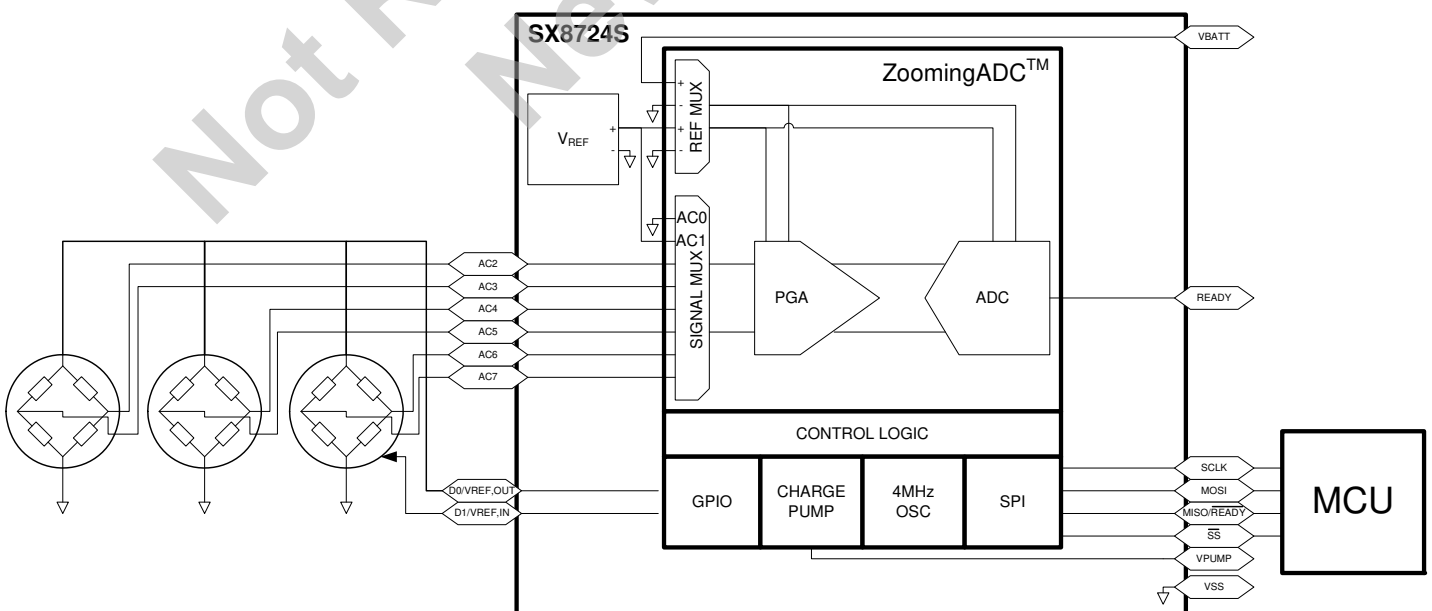

**TABLE OF CONTENT**

Section	Page
ELECTRICAL SPECIFICATIONS .....	4
1 Absolute Maximum Ratings .....	4
2 Operating Conditions .....	5
2.1 Timing Characteristics .....	9
2.1.1 POR Timings .....	9
2.1.2 SPI interface timings .....	10
2.1.3 SPI timing diagram .....	10
CIRCUIT DESCRIPTION .....	11
3 Pin Configuration .....	11
4 Marking Information .....	11
5 Pin Description .....	12
6 General Description .....	13
6.1 Bloc diagram .....	13
6.2 VREF .....	13
6.3 GPIO .....	13
6.3.1 Optional Operating Mode: External Vref .....	15
6.4 Charge Pump .....	16
6.5 RC Oscillator .....	16
6.5.1 Wake-up from sleep .....	16
7 ZoomingADC .....	17
7.1 Overview .....	17
7.1.1 Acquisition Chain .....	17
7.1.2 Programmable Gain Amplifiers .....	18
7.1.3 PGA & ADC Enabling .....	19
7.2 ZoomingADC Registers .....	19
7.3 Input Multiplexers (AMUX and VMUX) .....	20
7.4 First Stage Programmable Gain Amplifier (PGA1) .....	21
7.5 Second Stage Programmable Gain Amplifier (PGA2) .....	22
7.6 Third Stage Programmable Gain Amplifier (PGA3) .....	22
7.7 Analog-to-Digital Converter (ADC) .....	25
7.7.1 Conversion Sequence .....	25
7.7.2 Over-Sampling Frequency (fs) .....	26
7.7.3 Over-Sampling Ratio (OSR) .....	26
7.7.4 Number of Elementary Conversions (Nelconv) .....	26
7.7.5 Resolution .....	27
7.7.6 Conversion Time & Throughput .....	28
7.7.7 Continuous-Time vs. On-Request Conversion .....	29
7.7.8 Output Code Format .....	30
7.7.9 Power Saving Modes .....	32
8 Application hints .....	33
8.1 Power Reduction .....	33
8.2 Gain Configuration Flow .....	34
9 SPI interface .....	35
9.1 Overview .....	35
9.2 Data transmission .....	36
9.2.1 Write a single register .....	36

## TABLE OF CONTENT

Section	Page	
9.2.2	Read a single register . . . . .	36
9.2.3	Multiple Bytes Write/Read Protocol . . . . .	37
9.3	ADC Samples Reading . . . . .	38
9.3.1	SAMPLE SHIFT Mode . . . . .	39
9.3.2	COMBINED DATA READY Mode . . . . .	39
9.4	Chip Start Detection with Slave Select Pin . . . . .	42
9.5	Improving Noise Immunity . . . . .	43
10	Register Memory Map and Description . . . . .	44
10.1	Register Map . . . . .	44
10.2	Registers Descriptions . . . . .	44
10.2.1	RC Register . . . . .	45
10.2.2	GPIO Registers . . . . .	45
10.2.3	Software reset register . . . . .	46
10.2.4	ZADC Registers . . . . .	46
10.2.5	Mode Registers . . . . .	48
11	Typical Performances . . . . .	49
11.1	Input impedance . . . . .	49
11.1.1	Switched Capacitor Principle . . . . .	50
11.2	Frequency Response . . . . .	52
11.3	Linearity . . . . .	54
11.3.1	Integral Non-Linearity . . . . .	54
11.3.2	Differential Non-Linearity . . . . .	57
11.4	Noise . . . . .	57
11.5	Gain Error and Offset Error . . . . .	60
11.6	Power Consumption . . . . .	61
<b>FAMILY OVERVIEW . . . . .</b>		<b>63</b>
12	Comparison Table . . . . .	63
13	Comparison by package pinout . . . . .	64
<b>MECHANICAL . . . . .</b>		<b>65</b>
14	PCB Layout Considerations . . . . .	65
15	How to Evaluate . . . . .	65
16	Package Outline Drawing: MLPQ-W16-4x4-EP1 . . . . .	66
17	Land Pattern Drawing: MLPQ-W16-4x4-EP1 . . . . .	67
18	Tape and Reel Specification . . . . .	68

**ELECTRICAL SPECIFICATIONS**
**1 Absolute Maximum Ratings**

**Note** The Absolute Maximum Ratings, in table below, are stress ratings only. Functional operation of the device at conditions other than those indicated in the Operating Conditions sections of this specification is not implied.  
Exposure to the absolute maximum ratings, where different to the operating conditions, for an extended period may reduce the reliability or useful lifetime of the product.

**Table 1. Absolute Maximum Ratings**

Parameter	Symbol	Condition	Min	Max	Units
Power supply	VBATT		V <sub>SS</sub> - 0.3	6.5	V
Storage temperature	TSTORE		-55	150	°C
Temperature under bias	TBIAS		-40	140	°C
Input voltage	VINABS	All inputs	V <sub>SS</sub> - 300	VBATT + 300	mV
Peak reflow temperature	TPKG			260	°C
ESD conditions	ESDHBM	Human Body Model ESD	2000		V
Latchup			100		mA

## 2 Operating Conditions

Unless otherwise specified:  $V_{REF,ADC} = V_{BATT}$ ,  $V_{IN} = 0V$ , Over-sampling frequency  $f_s = 250$  kHz, PGA3 on with Gain = 1, PGA1&PGA2 off, offsets  $GDOff2 = GDOff3 = 0$ . Power operation: normal ( $I_{bAmpAdc}[1:0] = I_{bAmpPga}[1:0] = '01'$ ).

For resolution  $n = 12$  bits:  $OSR = 32$  and  $NELCONV = 4$ .

For resolution  $n = 16$  bits:  $OSR = 256$  and  $NELCONV = 2$ .

Bandgap chopped at  $NELCONV$  rate. If  $V_{BATT} < 3V$ , Charge Pump is forced on. If  $V_{BATT} > 3V$ , Charge Pump is forced off.

**Table 2. Operating conditions limits**

Parameter	Symbol	Comment/Condition	Min	Typ	Max	Unit
Power supply	$V_{BATT}$		2.4		5.5	V
Operating temperature	TOP		-40		125	°C

**Table 3. Electrical Characteristics**

Parameter	Symbol	Comment/Condition	Min	Typ	Max	Unit
<b>CURRENT CONSUMPTION<sup>1</sup></b>						
Active current, 5.5V	IOP55	16 b @ 250 Sample/s ADC, $f_s = 125$ kHz		250	300	$\mu A$
		16 b @ 1kSample/s PGA3 + ADC, $f_s = 500$ kHz		650	850	
		16 b + gain 1000 @ 1kSample/s PGA3,2,1 + ADC, $f_s = 500$ kHz		1000	1250	
Active current, 3.3V	IOP33	16 b @ 250 Sample/s ADC, $f_s = 125$ kHz		150		$\mu A$
		16 b @ 1 kSample/s PGA3 + ADC, $f_s = 500$ kHz		500		
		16 b + gain 1000 @ 1kSample/s PGA3,2,1 + ADC, $f_s = 500$ kHz		830		
Sleep current	ISLEEP	@25°C		150	250	nA
		up to 85°C		200		
		@125°C		250		
<b>TIME BASE</b>						
Max ADC Over-Sampling frequency	$f_{smax}$	@25°C	425	500	575	kHz
ADC Over-Sampling frequency drift	$f_{ST}$			0.15		% / °C
<b>DIGITAL I/O</b>						
Input logic high	$V_{IH}$		0.7			$V_{BATT}$
Input logic low	$V_{IL}$				0.3	$V_{BATT}$
Output logic high	$V_{OH}$	$I_{OH} < 4$ mA			$V_{BATT}-0.4$	V
Output logic low	$V_{OL}$	$I_{OL} < 4$ mA	0.4			V
<b>Leakages currents</b>						

**Table 3. Electrical Characteristics**

Parameter	Symbol	Comment/Condition	Min	Typ	Max	Unit
Input leakage current	$I_{LeakIn}$	Digital input mode, no pull-up or pull-down	-100		100	nA
<b>VREF: Internal Bandgap Reference</b>						
Absolute output voltage	VBG	$V_{BATT} > 3V$	1.19	1.22	1.25	V
Variation over Temperature	VBG <sub>T</sub>	$V_{BATT} > 3V$ , over Temperature	-1.5		+1.5	%
Total Output Noise	VBG <sub>N</sub>	$V_{BATT} > 3V$			1	mV <sub>rms</sub>

- The device can be operated in either active or sleep states. The Sleep state is complete shutdown, but the active state can have a variety of different current consumptions depending on the settings. Some examples are given here: The Sleep state is the default state after power-on-reset. The chip can then be placed into an active state after a valid I2C communication is received.

**Table 4. ZoomingADC Specifications**

Parameter	Symbol	Condition	Min	Typ	Max	Unit
<b>ANALOG INPUT CHARACTERISTICS</b>						
Differential Input Voltage Range $V_{IN} = V_{INP} - V_{INN}$		Gain=1, OSR=32, $V_{REF}=5V$ . <b>Note 1</b>	-2.42		+2.42	V
		Gain=100, OSR=32, $V_{REF}=5V$	-24.2		+24.2	mV
		Gain=1000, OSR=32, $V_{REF}=5V$	-2.42		+2.42	mV
<b>PROGRAMMABLE GAIN AMPLIFIER</b>						
Total PGA Gain	GDTOT	<b>Note 1</b>	1/12		1000	V/V
PGA1 Gain	GD1	(see <b>Table 10, page 22</b> )	1		10	V/V
PGA2 Gain	GD2	(see <b>Table 11, page 22</b> )	1		10	V/V
PGA3 Gain	GD3	Step = 1/12 V/V (see <b>Table 12, page 22</b> )	1/12		127/12	V/V
Gain Settings Precision (each stage)		Gain $\geq 1$	-3	$\pm 0.5$	+3	%
Gain Temperature Dependence				$\pm 5$		ppm / °C
PGA2 Offset	GDOFF2	Step = 0.2 V/V (see <b>Table 11, page 22</b> )	-1		+1	V/V
PGA3 Offset	GDOFF3	Step = 1/12 V/V (see <b>Table 12, page 22</b> )	-63/12		+63/12	V/V
Offset Settings Precision (PGA2 or PGA3)		<b>Note 2</b>	-3	$\pm 0.5$	+3	%
Offset Temperature Dependence				$\pm 5$		ppm / °C
Input Impedance on ADC	ZINADC		500			k $\Omega$
Input Impedance on PGA1 (see <b>section 11.1, page 49</b> )	ZINPGA1	Gain = 1. <b>Note 3</b>	900	1150		k $\Omega$
		Gain = 10. <b>Note 3</b>	250	350		k $\Omega$
Input Impedance on PGA2	ZINPGA2	Gain = 1. <b>Note 3</b>	500	1000		k $\Omega$
		Gain = 10. <b>Note 3</b>	125	270		k $\Omega$
Input Impedance on PGA3	ZINPGA3	Gain = 1. <b>Note 3</b>	500	780		k $\Omega$
		Gain = 10. <b>Note 3</b>	125	190		k $\Omega$

**Table 4. ZoomingADC Specifications**

Parameter	Symbol	Condition	Min	Typ	Max	Unit
Output RMS Noise per over-sample		PGA1. <a href="#">Note 4</a>		205		$\mu\text{V}$
		PGA2. <a href="#">Note 4</a>		340		$\mu\text{V}$
		PGA3. <a href="#">Note 4</a>		365		$\mu\text{V}$
<b>ADC STATIC PERFORMANCES</b>						
Resolution (No Missing Codes)	n	<a href="#">Note 5</a> <a href="#">Note 6</a>	6		16	Bits
Gain Error		<a href="#">Note 7</a>		$\pm 0.15$		%
Offset Error		n = 16 bits. <a href="#">Note 8</a>		$\pm 1$		LSB
Integral Non-Linearity	INL	resolution n = 12 bits. <a href="#">Note 9</a>		$\pm 0.6$		LSB
		resolution n = 16 bits. <a href="#">Note 9</a>		$\pm 1.5$		LSB
Differential Non-Linearity	DNL	resolution n = 12 bits. <a href="#">Note 10</a>		$\pm 0.5$		LSB
		resolution n = 16 bits. <a href="#">Note 10</a>		$\pm 0.5$		LSB
Power Supply Rejection Ratio DC	PSRR	$V_{\text{BATT}} = 5\text{V} \pm 0.3\text{V}$ . <a href="#">Note 11</a>		78		dB
		$V_{\text{BATT}} = 3\text{V} \pm 0.3\text{V}$ . <a href="#">Note 11</a>		72		dB
<b>ADC DYNAMIC PERFORMANCES</b>						
Conversion Time	$T_{\text{CONV}}$	n = 12 bits. <a href="#">Note 12</a>		133		fs cycles
		n = 16 bits. <a href="#">Note 12</a>		517		fs cycles
Throughput Rate (Continuous Mode)	$1/T_{\text{CONV}}$	n = 12 bits, $f_s = 250\text{ kHz}$		1.88		kSps
		n = 16 bits, $f_s = 250\text{ kHz}$		0.483		kSps
PGA Stabilization Delay		<a href="#">Note 13</a> (see <a href="#">Table 11</a> , <a href="#">page 22</a> )		OSR		fs cycles
<b>ZADC ANALOG QUIESCENT CURRENT</b>						
ADC Only Consumption	$I_{\text{Q}}$	$V_{\text{BATT}} = 5.5\text{V}/3.3\text{V}$		285/210		$\mu\text{A}$
PGA1 Consumption		$V_{\text{BATT}} = 5.5\text{V}/3.3\text{V}$		104/80		$\mu\text{A}$
PGA2 Consumption		$V_{\text{BATT}} = 5.5\text{V}/3.3\text{V}$		67/59		$\mu\text{A}$
PGA3 Consumption		$V_{\text{BATT}} = 5.5\text{V}/3.3\text{V}$		98/91		$\mu\text{A}$
<b>ANALOG POWER DISSIPATION: All PGAs &amp; ADC Active</b>						
Normal Power Mode		$V_{\text{BATT}} = 5.5\text{V}/3.3\text{V}$ . <a href="#">Note 14</a>		4.0/2.0		mW
3/4 Power Reduction Mode		$V_{\text{BATT}} = 5.5\text{V}/3.3\text{V}$ . <a href="#">Note 15</a>		3.2/1.6		mW
1/2 Power Reduction Mode		$V_{\text{BATT}} = 5.5\text{V}/3.3\text{V}$ . <a href="#">Note 16</a>		2.4/1.1		mW
1/4 Power Reduction Mode		$V_{\text{BATT}} = 5.5\text{V}/3.3\text{V}$ . <a href="#">Note 17</a>		1.5/0.7		mW

- (1) Gain defined as overall PGA gain  $G_{\text{DTOT}} = G_{\text{D1}} \times G_{\text{D2}} \times G_{\text{D3}}$ . Maximum input voltage is given by:  $V_{\text{IN,MAX}} = \pm(V_{\text{REF}} / 2) (OSR / OSR + 1)$ .
- (2) Offset due to tolerance on  $G_{\text{Doff2}}$  or  $G_{\text{Doff3}}$  setting. For small intrinsic offset, use only ADC and PGA1.
- (3) Measured with block connected to inputs through  $A_{\text{mux}}$  block. Normalized input sampling frequency for input impedance is  $f_s = 500\text{ kHz}$  ( $f_s$  max, worst case). This figure must be multiplied by 2 for  $f_s = 250\text{ kHz}$ , 4 for  $f_s = 125\text{ kHz}$ . Input impedance is proportional to  $1/f_s$ .
- (4) Figure independent from gain and sampling frequency.  $f_s$ . The effective output noise is reduced by the over-sampling ratio
- (5) Resolution is given by  $n = 2 \log_2(OSR) + \log_2(N_{\text{ELCONV}})$ .  $OSR$  can be set between 8 and 1024, in powers of 2.  $N_{\text{ELCONV}}$  can be set to 1, 2, 4 or 8.
- (6) If a ramp signal is applied to the input, all digital codes appear in the resulting ADC output data.
- (7) Gain error is defined as the amount of deviation between the ideal (theoretical) transfer function and the measured transfer function (with the offset error removed).
- (8) Offset error is defined as the output code error for a zero volt input (ideally, output code = 0). For 1 LSB offset,  $N_{\text{ELCONV}}$  must be at least 2.



- (9) INL defined as the deviation of the DC transfer curve of each individual code from the best-fit straight line. This specification holds over the full scale.
- (10) DNL is defined as the difference (in LSB) between the ideal (1 LSB) and measured code transitions for successive codes.
- (11) Values for Gain = 1. PSRR is defined as the amount of change in the ADC output value as the power supply voltage changes.
- (12) Conversion time is given by:  $T_{CONV} = (N_{ELCONV}(OSR + 1) + 1) / f_s$ . OSR can be set between 8 and 1024, in powers of 2.  $N_{ELCONV}$  can be set to 1, 2, 4 or 8.
- (13) PGAs are reset after each writing operation to registers **RegACCfg1-5**, corresponding to change of configuration or input switching. The ADC should be started only some delay after a change of PGA configuration through these registers. Delay between change of configuration of PGA or input channel switching and ADC start should be equivalent to OSR (between 8 and 1024) number of cycles. This is done by writing bit Start several cycles after PGA settings modification or channel switching. This delay does not apply to conversions made without the PGAs.
- (14) Nominal (maximum) bias currents in PGAs and ADC, i.e.  $I_{bAmpPga}[1:0] = '11'$  and  $I_{bAmpAdc}[1:0] = '11'$ .
- (15) Bias currents in PGAs and ADC set to 3/4 of nominal values, i.e.  $I_{bAmpPga}[1:0] = '10'$ ;  $I_{bAmpAdc}[1:0] = '10'$ .
- (16) Bias currents in PGAs and ADC set to 1/2 of nominal values, i.e.  $I_{bAmpPga}[1:0] = '01'$ ;  $I_{bAmpAdc}[1:0] = '01'$ .
- (17) Bias currents in PGAs and ADC set to 1/4 of nominal values, i.e.  $I_{bAmpPga}[1:0] = '00'$ ;  $I_{bAmpAdc}[1:0] = '00'$ .

Not Recommended for New Designs

## 2.1 Timing Characteristics

**Table 5. General timings**

Parameter	Symbol	Comment/Condition	Min	Typ	Max	Unit
<b>ADC INTERRUPT (READY) TIMING SPECIFICATIONS</b>						
READY pulse width	t <sub>IRQ</sub>	Note 18		1		1/f <sub>s</sub>
<b>STARTUP TIMES</b>						
Startup sequence time at POR	t <sub>STARTUP</sub>				800	μs
Time to enable RC from Sleep after a SPI command	t <sub>RCEN</sub>			100	450	μs
Effective Start	t <sub>START_SPI</sub>			250		μs

(18) The READY pulse indicates End of Conversion. This is a Positive pulse of duration equal to one cycle of the ADC sampling rate in “continuous mode”. See also [Figure 15, page 30](#) for data conversion waveforms.

### 2.1.1 POR Timings

The Slave Select pin ( $\overline{SS}$ ) can be used to detect the effective start of the device. See [section 9.4, page 42](#) for functional descriptions. The SPI interface can be accessed as soon as the  $\overline{SS}$  pin (slave) is set to ‘output’ as illustrated on [Figure 2](#).

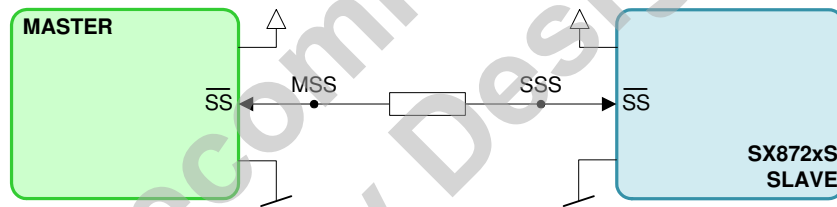

Figure 1. SPI Master detecting start sequence through Slave Select pin

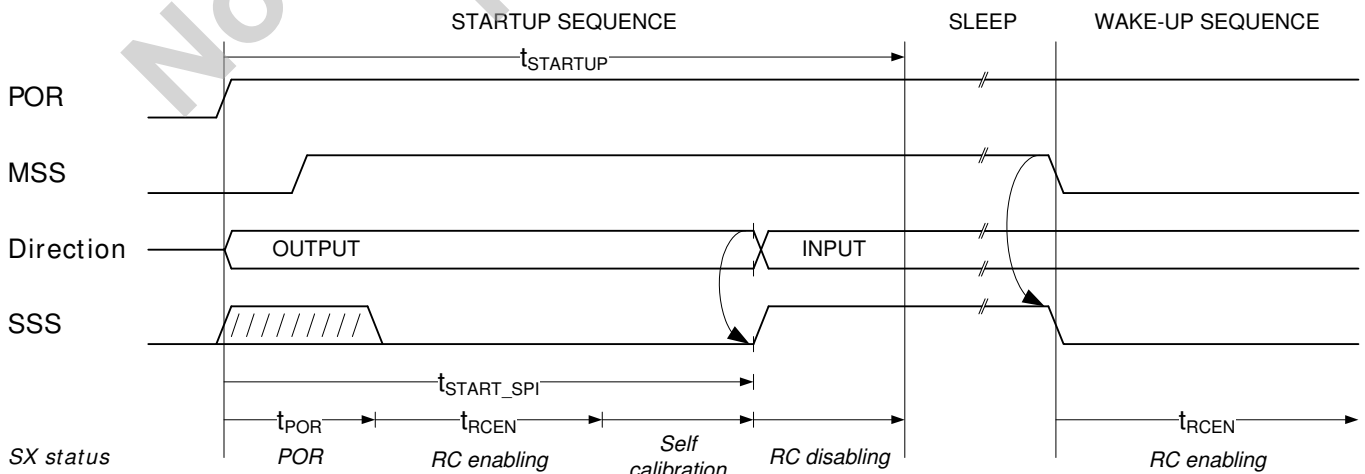

Figure 2. Slave Select pin and Power-On-Reset Timings

**2.1.2 SPI interface timings**

Parameter	Symbol	Min	Typ	Max	Units
$\overline{SS}$ to SCLK Edge	t <sub>SSSC</sub>	30			ns
SCLK Period	t <sub>SC</sub>	250	500		ns
SCLK Low Pulse width	t <sub>SCL</sub>	100			ns
SCLK High Pulse width	t <sub>SCH</sub>	100			ns
Data Output Valid after SCLK Edge	t <sub>DV</sub>		125	200	ns
Data Input Setup Time before SCLK Edge	t <sub>DS</sub>	0			ns
Data Input Hold Time after SCLK Edge	t <sub>DH</sub>	100	250		ns
$\overline{SS}$ High after SCLK Edge	t <sub>SSSC</sub>	0			ns
$\overline{SS}$ High to MISO High Impedance	t <sub>SSD</sub>			30	ns

**2.1.3 SPI timing diagram**

Figure 3. SPI timing diagram

## CIRCUIT DESCRIPTION

### 3 Pin Configuration

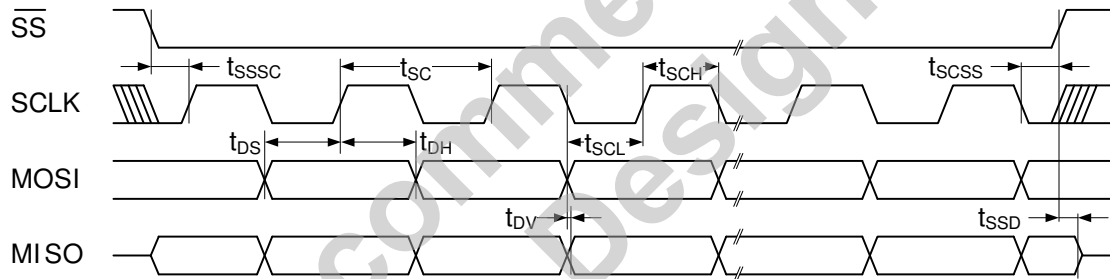
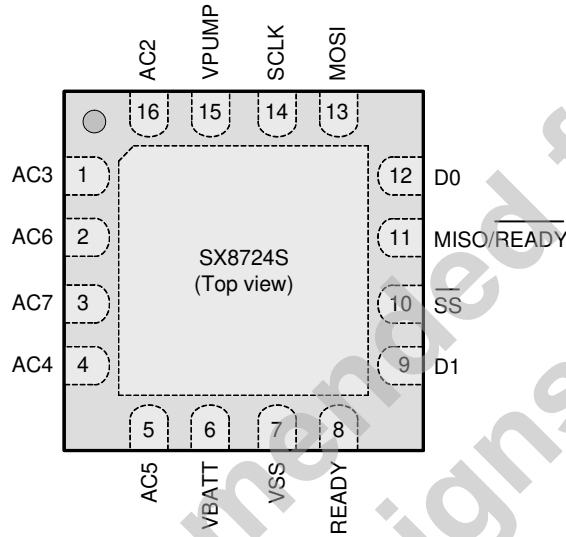

### 4 Marking Information



nnnnn = Part Number  
 yyww = Date Code<sup>1</sup>  
 xxxxx = Semtech Lot Number  
 xxxxx

<sup>1</sup>.Date codes and Lot numbers starting with the 'E' character are used for Engineering samples

## 5 Pin Description

**Note** The bottom pad is internally connected to VSS. It should also be connected to VSS on PCB to reduce noise and improve thermal behavior.

Pin	Name	Type	Function
1	AC3	Analog Input	Differential sensor input in conjunction with AC2
2	AC6	Analog Input	Differential sensor input in conjunction with AC7
3	AC7	Analog Input	Differential sensor input in conjunction with AC6
4	AC4	Analog Input	Differential sensor input in conjunction with AC5
5	AC5	Analog Input	Differential sensor input in conjunction with AC4
6	VBATT	Power Input	2.4V to 5.5V power supply
7	VSS	Power Input	Chip Ground
8	READY	Digital Output	Data Ready (active high). Conversion complete flag.
9	D1	Digital IO	Digital output sensor drive (VBATT or VSS)
		Analog	V <sub>REF</sub> Input in optional operating mode
10	$\overline{SS}$	Digital Input	Slave select (active low). This pin is set as output low during the POR sequence.
11	MISO/ $\overline{READY}$	Digital Output	Serial data out (Master Input, Slave Output), or data out combined with Data Ready (active low when Data Ready function enabled).
12	D0	Digital IO	Digital output sensor drive (VBATT or VSS)
		Analog	V <sub>REF</sub> Output in optional operating mode
13	MOSI	Digital Input	Serial data in (Master Output, Slave Input)
14	SCLK	Digital Input	Serial clock from the Master.
15	VPUMP	Power IO	Charge pump output. Raises ADC supply above VBATT if VBATT supply is too low. Recommended range for capacitor is 1nF to 10 nF. Connect the capacitor to ground.
16	AC2	Analog Input	Differential sensor input in conjunction with AC3

## 6 General Description

The SX8724S is a complete low-power acquisition path with programmable gain, acquisition speed and resolution.

### 6.1 Bloc diagram

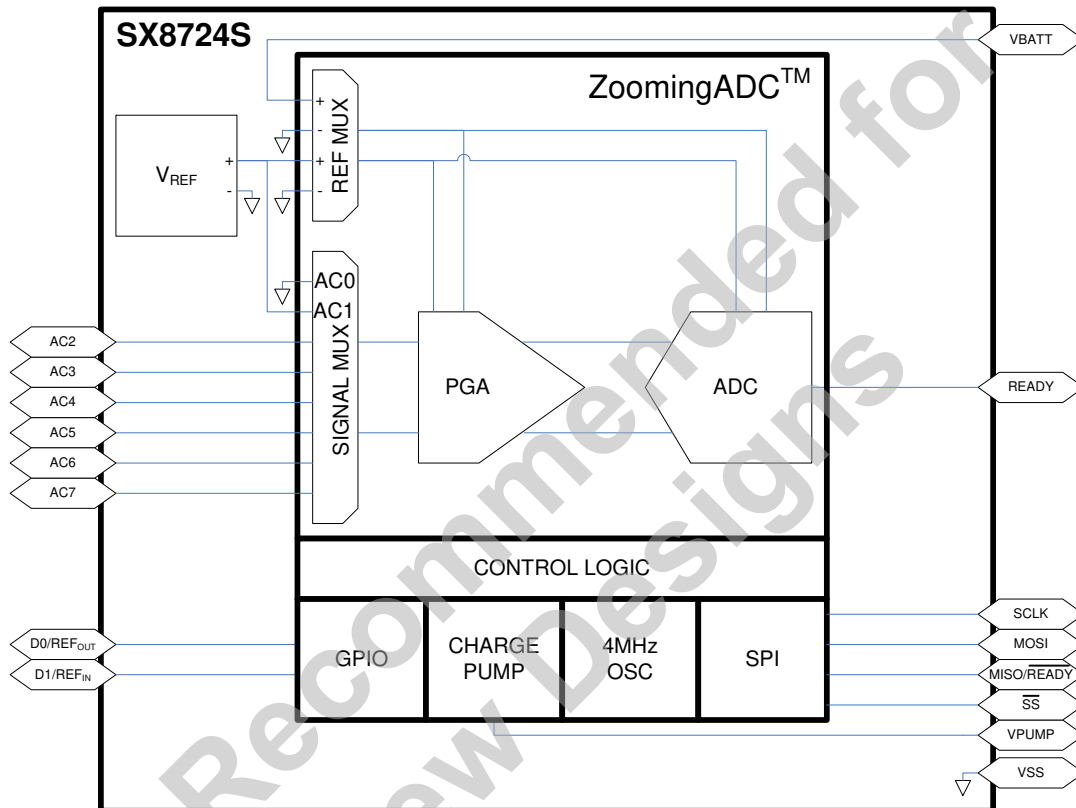

Figure 4. SX8724S bloc diagram

### 6.2 VREF

The internally generated  $V_{REF}$  is a trimmed bandgap reference with a nominal value of 1.22V that provides a stable voltage reference for the ZoomingADC.

This reference voltage is directly connected to one of the ZoomingADC reference multiplexer inputs.

The bandgap voltage stability is only guaranteed for  $V_{BATT}$  voltages of 3V and above. As  $V_{BATT}$  drops down to 2.4V, the bandgap voltage could reduce by up to 50mV.

The bandgap has relatively weak output drive so it is recommended that if the bandgap is required as a signal input then  $PGA1$  must be enabled with gain = 1.

### 6.3 GPIO

The  $GPIO$  block is a multipurpose 2 bit input/output port. In addition to digital behavior,  $D0$  and  $D1$  pins can be programmed as analog pins in order to be used as output (reference voltage monitoring) and input for an external

reference voltage (For further details see [Figure 7](#), [Figure 8](#), [Figure 9](#) and [Figure 10](#)). Each port terminal can be individually selected as digital input or output.

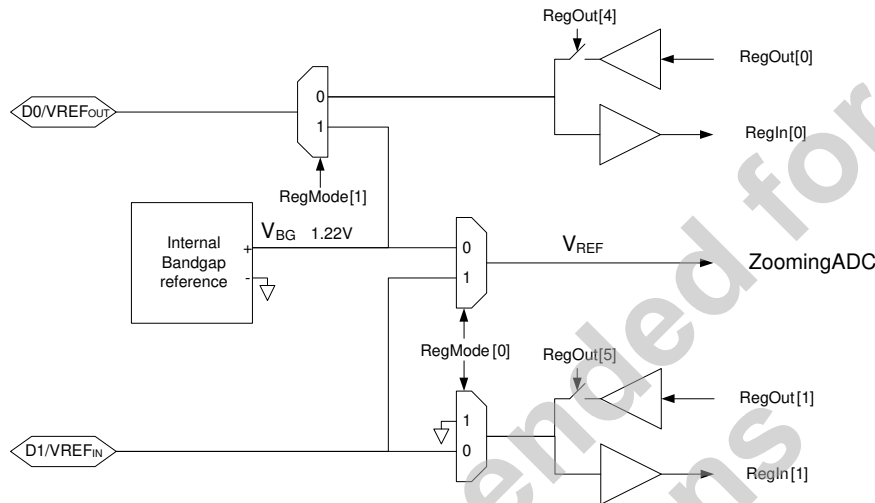

Figure 5. GPIO bloc diagram

The direction of each bit within the *GPIO* block (input only or input/output) can be individually set using the bits of the **RegOut** (address 0x40) register. If  $D[x]Dir = 1$ , both the input and output buffer are active on the corresponding *GPIO* block pin. If  $D[x]Dir = 0$ , the corresponding *GPIO* block pin is an input only and the output buffer is in high impedance. After power on reset the *GPIO* block pins are in input/output mode ( $D[x]Dir$  are reset to 1).

The input values of *GPIO* block are available in **RegIn** (address 0x41) register (read only). Reading is always direct - there is no debounce function in the *GPIO* block. In case of possible noise on input signals, an external hardware filter has to be realized. The input buffer is also active when the *GPIO* block is defined as output and the effective value on the pin can be read back.

Data stored in the LSB bits of **RegOut** register are outputted at *GPIO* block if  $D[x]Dir = 1$ . The default values after power on reset is low (0).

The digital pins are able to deliver a driving current up to 8 mA.

When the bits  $VrefD0Out$  and  $VrefD1In$  in the **RegMode** (address 0x70) register are set to 1 the *D0* and *D1* pins digital behavior are automatically bypassed in order to either input or output the voltage reference signals.

### 6.3.1 Optional Operating Mode: External Vref

*D0* and *D1* are multi-functional pins with the following functions in different operating modes (see **RegMode** register for control settings):

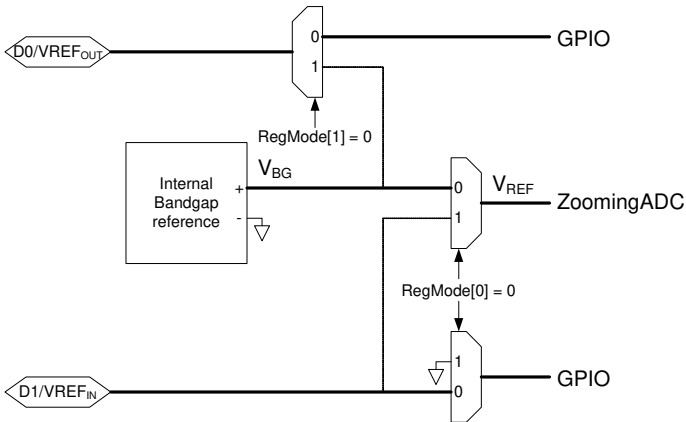

Figure 7. *D0* and *D1* are Digital Inputs / Outputs

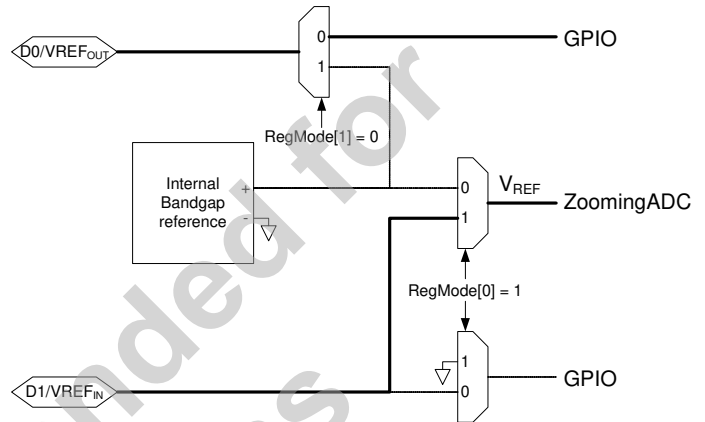

Figure 8. *D1* is Reference Voltage Input and *D0* is Digital Input / Output

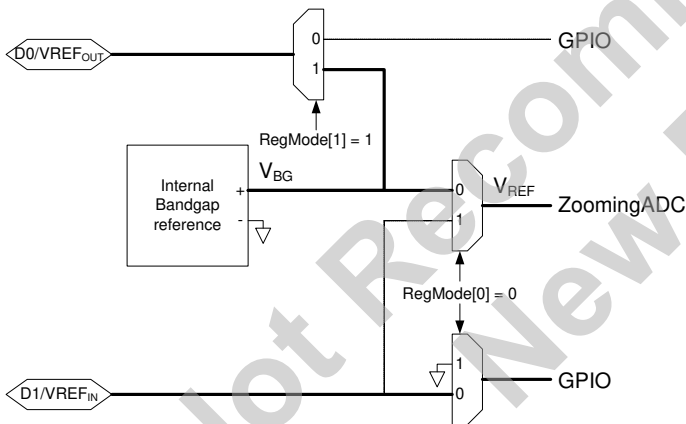

Figure 9. *D1* is Digital Input / Output and *D0* Reference Voltage Output

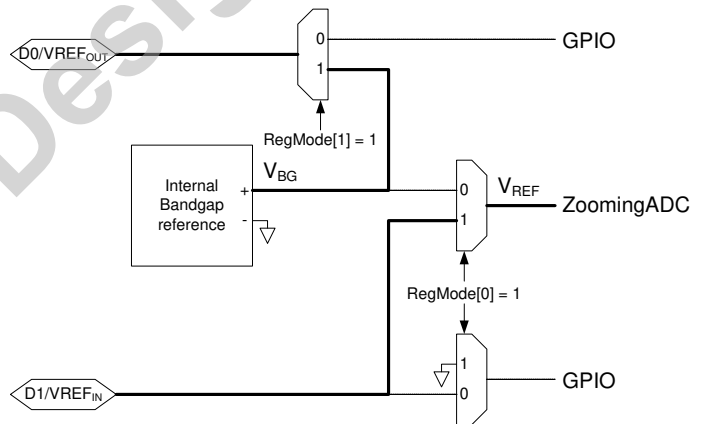

Figure 10. *D0* is Reference Voltage Output and *D1* is Reference Voltage Input

This allows external monitoring of the internal bandgap reference or the ability to use an external reference input for the ADC, or the option to filter the internal  $V_{REF}$  output before feeding back as  $V_{REF,ADC}$  input. The internally generated  $V_{REF}$  is a trimmed as ADC reference with a nominal value of 1.22V. When using an external  $V_{REF,ADC}$  input, it may have any value between 0V and  $V_{BATT}$ . Simply substitute the external value for 1.22 V in the ADC conversion calculations.



## 6.4 Charge Pump

This block generates a supply voltage able to power the analog switch drive levels on the chip higher than  $V_{BATT}$  if necessary.

If  $V_{BATT}$  voltage drops below 3V then the block should be activated. If  $V_{BATT}$  voltage is greater than 3V then  $V_{BATT}$  may be switched straight through to the  $VPUMP$  output. If the charge pump is not activated then  $VPUMP = V_{BATT}$ .

If control input bit  $MultForceOff = 1$  in **RegMode** (address 0x70) register then the charge pump is disabled and  $V_{BATT}$  is permanently connected to  $VPUMP$  output.

If control input bit  $MultForceOn = 1$  in **RegMode** register then the charge pump is permanently enabled. This overrides  $MultForceOff$  bit in **RegMode** register.

An external capacitor is required on  $VPUMP$  pin. This capacitor should be large enough to ensure that generated voltage is smooth enough to avoid affecting conversion accuracy but not so large that it gives an unacceptable settling time. A recommended value is around 2.2nF.

## 6.5 RC Oscillator

This block provides the master clock reference for the chip. It produces a clock at 4 MHz which is divided internally in order to generate the clock sources needed by the other blocks.

The oscillator technique is a low power relaxation design and it is designed to vary as little as possible over temperature and supply voltage.

This oscillator is trimmed at manufacture chip test.

The  $RC$  oscillator will start up after a chip reset to allow the trimming values to be read and calibration registers. Once this has been done, the oscillator will be shut down and the chip will enter a sleep state while waiting for a SPI communication.

The worst case duration from reset ( or POR ) to the sleep state is 800us.

### 6.5.1 Wake-up from sleep

When the device is in sleep state, the  $RC$  oscillator will start up after a communication. The start up sequence for the  $RC$  oscillator is 450us in worst case.

During this time, the internal blocs using the  $RC$  can not be used: no ADC conversion can be started.

## 7 ZoomingADC

### 7.1 Overview

The *ZoomingADC* is a complete and versatile low-power analog front-end interface typically intended for sensing applications. In the following text the *ZoomingADC* will be referred as *ZADC*.

The key features of the *ZADC* are:

- Programmable 6 to 16-bit dynamic range over-sampled ADC
- Flexible gain programming between 1/12 and 1000
- Flexible and large range offset compensation
- Differential or single-ended input
- 2-channel differential reference inputs
- Power saving modes

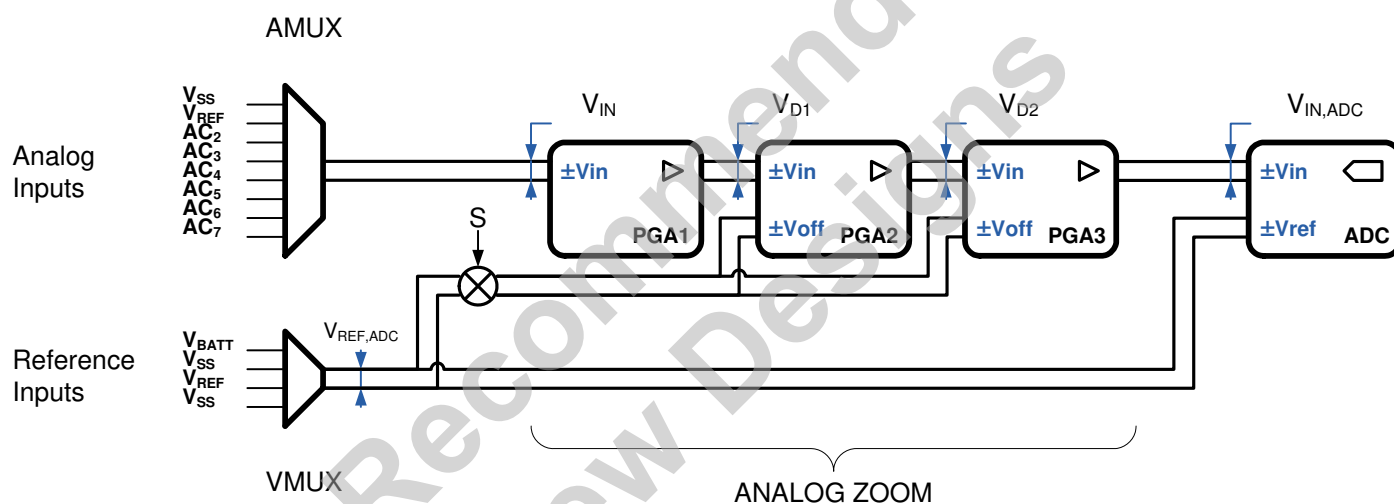

Figure 11. ZADC General Functional Block Diagram

The total acquisition chain consists of an input multiplexer, 3 programmable gain amplifier stages and an over sampled A/D converter. The reference voltage can be selected on two different channels. Two offset compensation amplifiers allow for a wide offset compensation range. The programmable gain and offset allow the application to zoom in on a small portion of the reference voltage defined input range.

#### 7.1.1 Acquisition Chain

**Figure 11, page 17** shows the general block diagram of the acquisition chain (AC). A control block (not shown in **Figure 11**) manages all communications with the SPI peripheral. The clocking is derived from the internal 4 MHz Oscillator.

Analog inputs can be selected through an 8 input multiplexer, while reference input is selected between two differential channels. It should however be noted that only 7 acquisition channels (including the VREF) are available when configured as single ended since the input amplifier is always operating in differential mode with both positive and negative input selected through the multiplexer.

The core of the zooming section is made of three differential programmable amplifiers (*PGA*). After selection of an input and reference signals  $V_{IN}$  and  $V_{REF,ADC}$  combination, the input voltage is modulated and amplified through stages 1 to 3. Fine gain programming up to 1'000 V/V is possible. In addition, the last two stages provide programmable offset. Each amplifier can be bypassed if needed.

The output of the cascade of *PGA* is directly fed to the analog-to-digital converter (*ADC*), which converts the signal  $V_{IN,ADC}$  into digital.

Like most *ADCs* intended for instrumentation or sensing applications, the ZoomingADC™ is an over-sampled converter<sup>1</sup>. The *ADC* is a so-called incremental converter; with bipolar operation (the *ADC* accepts both positive and negative differential input voltages). In first approximation, the *ADC* output result relative to full-scale (*FS*) delivers the quantity:

$$\frac{OUT_{ADC}}{FS/2} \cong \frac{V_{IN,ADC}}{V_{REF}/2}$$

**Equation 1**

in two's complement (see [Equation 18](#) and [Equation 19](#), page 30 for details). The output code  $OUT_{ADC}$  is  $-FS/2$  to  $+FS/2$  for  $V_{IN,ADC} = -V_{REF,ADC}/2$  to  $+V_{REF,ADC}/2$  respectively. As will be shown,  $V_{IN,ADC}$  is related to input voltage  $V_{IN}$  by the relationship:

$$V_{IN,ADC} = GD_{TOT} \cdot V_{IN} - GD_{OffTOT} \cdot S \cdot V_{REF} \quad [V]$$

**Equation 2**

where  $GD_{TOT}$  is the total *PGA* gain,  $GD_{OffTOT}$  is the total magnitude of *PGA* offset and  $S$  is the sign of the offset (see [Table 8](#), page 21).

### 7.1.2 Programmable Gain Amplifiers

As seen in [Figure 11](#), page 17, the zooming function is implemented with three programmable gain amplifiers (*PGA*). These are:

- *PGA1*: coarse gain tuning
- *PGA2*: medium gain and offset tuning
- *PGA3*: fine gain and offset tuning. Should be set ON for high linearity data acquisition

All gain and offset settings are realized with ratios of capacitors. The user has control over each *PGA* activation and gain, as well as the offset of stages 2 and 3. These functions are examined hereafter.

1. Over-sampled converters are operated with a sampling frequency  $f_s$  much higher than the input signal's Nyquist rate (typically  $f_s$  is 20-1'000 times the input signal bandwidth). The sampling frequency to throughput ratio is large (typically 10-500). These converters include digital decimation filtering. They are mainly used for high resolution, and/or low-to-medium speed applications.

### 7.1.3 PGA & ADC Enabling

Depending on the application objectives, the user may enable or bypass each *PGA* stage. This is done according to the word *Enable* and the coding given in **Table 6**. To reduce power dissipation, the *ADC* can also be inactivated while idle.

**Table 6. ADC and PGA Enabling**

Enable (RegACCfg1[3:0])	Block
XXX0 XXX1	ADC disabled ADC enabled
XX0X XX1X	PGA1 disabled PGA1 enabled
X0XX X1XX	PGA2 disabled PGA2 enabled
0XXX 1XXX	PGA3 disabled PGA3 enabled

### 7.2 ZoomingADC Registers

The system has a bank of eight 8-bit registers: six registers are used to configure the acquisition chain (**RegAcCfg0** to **RegAcCfg5**), and two registers are used to store the output code of the analog-to-digital conversion (**RegAcOutMsb** & **Lsb**).

**Table 7. Registers to Configure the Acquisition Chain (AC) and to Store the Analog-to-Digital Conversion (ADC) Result**

Register Name	Bit position							
	7	6	5	4	3	2	1	0
RegACOutLsb	Out[7:0] <b>Note 1</b>							
RegACOutMsb	Out[15:8]							
RegACCfg0 Default values:	Start 0, <b>Note 2</b>	SetNelconv 01, <b>Note 3</b>		SetOsr 010, <b>Note 4</b>			Continuous 0, <b>Note 5</b>	SampleShiftEn 0, <b>Note 6</b>
RegACCfg1 Default value:	IbAmpAdc 11, <b>Note 7</b>		IbAmpPga 11, <b>Note 8</b>		Enable 0000, <b>Note 9</b>			
RegACCfg2 Default value:	SetFs 00, <b>Note 10</b>		Pga2Gain 00, <b>Note 12</b>		Pga2Offset 0000, <b>Note 14</b>			
RegACCfg3 Default value:	Pga1Gain 0, <b>Note 11</b>	Pga3Gain 0001100, <b>Note 13</b>						
RegACCfg4 Default value:	DataReadyEn 0, <b>Note 15</b>	Pga3Offset 0000000, <b>Note 16</b>						
RegACCfg5 Default value:	Busy 0, <b>Note 17</b>	Def 0, <b>Note 18</b>	Amux 00000, <b>Note 19</b>				Vmux 0, <b>Note 20</b>	

(r = read; w = write; rw = read & write)

- (1) **Out:** (r) digital output code of the analog-to-digital converter. (*MSB* = *Out[15]*)  
 (2) **Start:** (w) setting this bit triggers a single conversion (after the current one is finished). This bit always reads back 0.

- (3) **SetNelconv:** (rw) sets the number of elementary conversions to  $2^{(SetNelconv[1:0])}$ . To compensate for offsets, the input signal is chopped between elementary conversions (1,2,4,8).
- (4) **SetOsr:** (rw) sets the over-sampling rate (*OSR*) of an elementary conversion to  $2^{(3+SetOsr[2:0])}$ . *OSR* = 8, 16, 32, ..., 512, 1024.
- (5) **Continuous:** (rw) setting this bit starts a conversion. When this bit is 1, A new conversion will automatically begin directly when the previous one is finished.
- (6) **SampleShiftEn:** (rw) the 16-bit samples can be directly shifted out through the SPI interface by the master when a conversion is done.
- (7) **IbAmpAdc:** (rw) sets the bias current in the ADC to  $0.25 \times (1 + IbAmpAdc[1:0])$  of the normal operation current (25, 50, 75 or 100% of nominal current). To be used for low-power, low-speed operation.
- (8) **IbAmpPga:** (rw) sets the bias current in the PGAs to  $0.25 \times (1 + IbAmpPga[1:0])$  of the normal operation current (25, 50, 75 or 100% of nominal current). To be used for low-power, low-speed operation.
- (9) **Enable:** (rw) enables the ADC modulator (bit 0) and the different stages of the PGAs (*PGAi* by bit  $i=1,2,3$ ). PGA stages that are disabled are bypassed.
- (10) **SetFs:** (rw) These bits set the over sampling frequency of the acquisition chain. Expressed as a fraction of the oscillator frequency, the sampling frequency is given as: 11 ' 500 kHz, 10 ' 250 kHz, 01 ' 125 kHz, 00 ' 62.5 kHz.
- (11) **Pga1Gain:** (rw) sets the gain of the first stage: 0 ' 1, 1 ' 10.
- (12) **Pga2Gain:** (rw) sets the gain of the second stage: 00 ' 1, 01 ' 2, 10 ' 5, 11 ' 10.
- (13) **Pga3Gain:** (rw) sets the gain of the third stage to *Pga3Gain*[6:0] 1/12.
- (14) **Pga2Offset:** (rw) sets the offset of the second stage between -1 and +1, with increments of 0.2. The *MSB* gives the sign (0 positive, 1 negative); amplitude is coded with the bits *Pga2Offset*[5:0].
- (15) **DataReadyEn:** (rw) enables the combined data ready mode with the MISO of the SPI interface.
- (16) **Pga3Offset:** (rw) sets the offset of the third stage between -5.25 and +5.25, with increments of 1/12. The *MSB* gives the sign (0 positive, 1 negative); amplitude is coded with the bits *Pga3Offset*[5:0].
- (17) **Busy:** (r) set to 1 if a conversion is running.
- (18) **Def:** (w) sets all values to their defaults (PGA disabled, *AMux* not changed, *VMux* not changed, ADC enabled, nominal modulator bias current (100%), 2 elementary conversions, *OSR* = 32, *NELCONV* = 2, *fs* = 62.5kHz) and starts a new conversion without waiting the end of the preceding one.
- (19) **Amux(4:0):** (rw) *Amux*[4] sets the mode (0 ' differential inputs, 1 ' single ended inputs with A0= common reference) *Amux*[3] sets the sign (0 ' straight, 1 ' cross) *Amux*[2:0] sets the channel.
- (20) **Vmux:** (rw) sets the differential reference channel (0 ' *VBATT*, 1 ' *VREF*).

### 7.3 Input Multiplexers (AMUX and VMUX)

The ZoomingADC has analog inputs *AC0* to *AC7* and reference inputs. Let us first define the differential input voltage *V<sub>IN</sub>* and reference voltage *V<sub>REF,ADC</sub>* respectively as:

$$V_{IN} = V_{INP} - V_{INN} \quad [V]$$

Equation 3

$$V_{REF} = V_{REFP} - V_{REFN} \quad [V]$$

Equation 4

As shown in [Table 8](#), the inputs can be configured in two ways: either as 4 differential channels ( $V_{IN1} = AC1 - AC0, \dots, V_{IN4} = AC7 - AC6$ ), or  $AC0$  can be used as a common reference, providing 7 signal paths all referred to  $AC0$ . The control word for the analog input selection is  $Amux$ . Notice that the  $Amux$  bit 4 controls the sign of the input voltage.

**Table 8. Analog Input Selection**

<b>Amux (RegACCfg5[5:1])</b>	<b>V<sub>INP</sub></b>	<b>V<sub>INN</sub></b>	<b>Amux (RegACCfg5[5:1])</b>	<b>V<sub>INP</sub></b>	<b>V<sub>INN</sub></b>
<b>Sign S = 1</b>			<b>Sign S = -1</b>		
00x00	AC1(VREF)	AC0(Vss)	01x00	AC1(Vss)	AC0(VREF)
00x01	AC3	AC2	01x01	AC2	AC3
00x10	AC5	AC4	01x10	AC4	AC5
00x11	AC7	AC6	01x11	AC6	AC7
10000	AC0(Vss)	AC0(Vss)	11000	AC0(Vss)	AC0(Vss)
10001	AC1(VREF)		11001		AC1(VREF)
10010	AC2		11010		AC2
10011	AC3		11011		AC3
10100	AC4		11100		AC4
10101	AC5		11101		AC5
10110	AC6		11110		AC6
10111	AC7		11111		AC7

Similarly, the reference voltage is chosen among two differential channels ( $V_{REF} = V_{BATT} - V_{SS}$ ,  $V_{REF} = V_{BG} - V_{SS}$  or  $V_{REF} = V_{REF,IN} - V_{SS}$ ) as shown in [Table 9](#). The selection bit is  $V_{mux}$ . The reference inputs  $V_{REFP}$  and  $V_{REFN}$  (common-mode) can be up to the power supply range.

**Table 9. Analog reference Input Selection**

<b>V<sub>mux</sub> (RegACCfg5[0])</b>	<b>V<sub>REFP</sub></b>	<b>V<sub>REFN</sub></b>
0	$V_{REF} = V_{BATT}$	$V_{SS}$
1	$V_{REF} = V_{BG}$ or $V_{REF,IN}$ <sup>1</sup>	$V_{SS}$

1. External voltage reference on D1 GPIO pin. See [section 6.3 on page 13](#) about GPIO and "RegMode[0x70]" on page 48.

## 7.4 First Stage Programmable Gain Amplifier (PGA1)

The first stage can have a buffer function (unity gain) or provide a gain of 10 (see [Table 10](#)). The voltage  $V_{D1}$  at the output of  $PGA1$  is:

$$V_{D1} = GD_1 \cdot V_{IN} \quad [V]$$

**Equation 5**

where  $GD_1$  is the gain of  $PGA_1$  (in V/V) controlled with the  $Pga1Gain$  bit.

**Table 10. PGA1 gain settings**

Pga1Gain bit (RegACCFg3[7])	PGA1 gain [V/V] $GD_1$ [V/V]
0	1
1	10

### 7.5 Second Stage Programmable Gain Amplifier (PGA2)

The second  $PGA$  has a finer gain and offset tuning capability, as shown in [Table 11](#). The  $VD_2$  voltage at the output of  $PGA_2$  is given by:

$$V_{D_2} = GD_2 \cdot V_{D_1} - GD_{off_2} \cdot S \cdot V_{REF} \quad [V]$$

**Equation 6**

where  $GD_2$  and  $GD_{OFF_2}$  are respectively the gain and offset of  $PGA_2$  (in V/V). These are controlled with the words  $Pga2Gain[1:0]$  and  $Pga2Offset[3:0]$ .

**Table 11. PGA2 gain and offset settings**

Pga2Gain bit field (RegACCFg2[5:4])	PGA2 gain [V/V] $GD_2$ [V/V]	Pga2Offset bit field (RegACCFg2[3:0])	PGA2 offset $GD_{OFF_2}$ [V/V]
00	1	0000	0
01	2	0001	+0.2
10	5	0010	+0.4
11	10	0011	+0.6
		0100	+0.8
		0101	+1
		1000	0
		1001	-0.2
		1010	-0.4
		1011	-0.6
		1100	-0.8
		1101	-1.0

### 7.6 Third Stage Programmable Gain Amplifier (PGA3)

The finest gain and offset tuning is performed with the third and last  $PGA$  stage, according to the coding of [Table 12](#).

**Table 12. PGA3 Gain and Offset Settings**

Pga3Gain bit field (RegACCFg3[6:0])	PGA3 Gain $GD_3$ [V/V]	Pga3Offset bit field (RegACCFg4[6:0])	PGA3 Offset $GD_{OFF_3}$ [V/V]
0000000	0	0000000	0
0000001	1/12 (=0.083)	0000001	+1/12 (=0.083)

**Table 12. PGA3 Gain and Offset Settings**

Pga3Gain bit field (RegACCfg3[6:0])	PGA3 Gain $GD_3$ [V/V]	Pga3Offset bit field (RegACCfg4[6:0])	PGA3 Offset $GDOff_3$ [V/V]
...	...	...	...
0000110	6/12	0010000	+16/12
...	...	...	...
0001100	12/12	0100000	32/12
0010000	16/12	...	...
...	...	0111111	+63/12 (=+5.25)
0100000	32/12	1000000	0
...	...	1000001	-1/12 (= -0.083)
1000000	64/12	1000010	-2/12
...	...	...	...
1111111	127/12 (=10.58)	1010000	-16/12
		...	...
		1100000	-32/12
		...	...
		1111111	-63/12 (= -5.25)

The output of  $PGA_3$  is also the input of the ADC. Thus, similarly to  $PGA_2$ , we find that the voltage entering the ADC is given by:

$$V_{IN,ADC} = GD_3 \cdot V_{D2} - GDOff_3 \cdot S \cdot V_{REF} \quad [V]$$

**Equation 7**

where  $GD_3$  and  $GDOff_3$  are respectively the gain and offset of  $PGA_3$  (in V/V). The control words are  $Pga3Gain[6:0]$  and  $Pga3Offset[6:0]$ .

To remain within the signal compliance of the  $PGA$  stages (no saturation), the condition:

$$|V_{IN}|, |V_{D1}|, |V_{D2}| < \frac{V_{BATT}}{2}$$

**Equation 8**

must be verified.



To remain within the signal compliance of the ADC (no saturation), the condition:

$$|V_{IN,ADC}| < \left( \frac{V_{REF}}{2} \right) \left( \frac{OSR-1}{OSR} \right)$$

**Equation 9**

must be verified.

Finally, combining **Equation 5** to **Equation 7** for the three PGA stages, the input voltage  $V_{IN,ADC}$  of the ADC is related to  $V_{IN}$  by:

$$V_{IN,ADC} = GD_{TOT} \cdot V_{IN} - GDoff_{TOT} \cdot S \cdot V_{REF} \quad [V]$$

**Equation 10**

where the total PGA gain is defined as:

$$GD_{TOT} = GD_3 \cdot GD_2 \cdot GD_1$$

**Equation 11**

and the total PGA offset is:

$$GDoff_{TOT} = GDoff_3 + GD_3 \cdot GDoff_2$$

**Equation 12**

## 7.7 Analog-to-Digital Converter (ADC)

The main performance characteristics of the ADC (resolution, conversion time, etc.) are determined by three programmable parameters. The setting of these parameters and the resulting performances are described later.

- $f_s$ : Over-sampling frequency
- $OSR$ : Over-Sampling Ratio
- $NELCONV$ : Number of Elementary Conversions

### 7.7.1 Conversion Sequence

A conversion is started each time the bit *Start* or the *Def* bit is set. As depicted in [Figure 12](#), a complete analog-to-digital conversion sequence is made of a set of  $NELCONV$  elementary incremental conversions and a final quantization step. Each elementary conversion is made of  $(OSR+1)$  over-sampling periods  $T_s=1/f_s$ , i.e.:

$$T_{ELCONV} = (OSR+1) / f_s \quad [s]$$

Equation 13

The result is the mean of the elementary conversion results. An important feature is that the elementary conversions are alternatively performed with the offset of the internal amplifiers contributing in one direction and the other to the output code. Thus, converter internal offset is eliminated if at least two elementary sequences are performed (i.e. if  $NELCONV \geq 2$ ). A few additional clock cycles are also required to initiate and end the conversion properly.

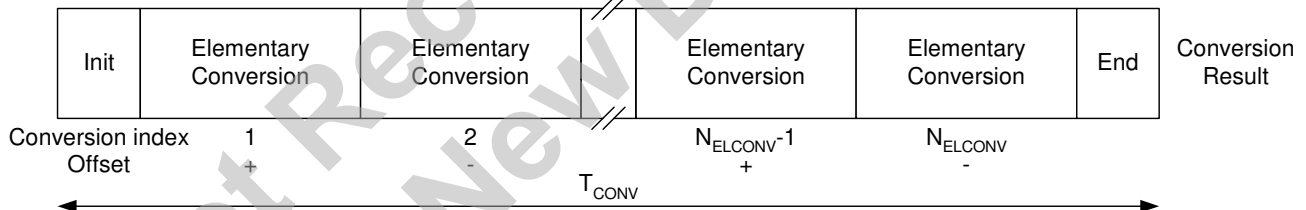

Figure 12. Analog-to-Digital Conversion Sequence

---

**Note** The internal bandgap reference state may be forced High or Low, or may be set to toggle during conversion at either the same rate or half the rate of the Elementary Conversion. This may be useful to help eliminate bandgap related internal offset voltage and  $1/f_s$  noise.

---