



Chipsmall Limited consists of a professional team with an average of over 10 year of expertise in the distribution of electronic components. Based in Hongkong, we have already established firm and mutual-benefit business relationships with customers from,Europe,America and south Asia,supplying obsolete and hard-to-find components to meet their specific needs.

With the principle of “Quality Parts,Customers Priority,Honest Operation,and Considerate Service”,our business mainly focus on the distribution of electronic components. Line cards we deal with include Microchip,ALPS,ROHM,Xilinx,Pulse,ON,Everlight and Freescale. Main products comprise IC,Modules,Potentiometer,IC Socket,Relay,Connector.Our parts cover such applications as commercial,industrial, and automotives areas.

We are looking forward to setting up business relationship with you and hope to provide you with the best service and solution. Let us make a better world for our industry!



Contact us

Tel: +86-755-8981 8866 Fax: +86-755-8427 6832

Email & Skype: info@chipsmall.com Web: www.chipsmall.com

Address: A1208, Overseas Decoration Building, #122 Zhenhua RD., Futian, Shenzhen, China



DESCRIPTION

The SX8725C is a data acquisition system based on Semtech's low power ZoomingADC™ technology. It directly connects most types of miniature sensors with a general purpose microcontroller.

With 1 differential input, it can adapt to multiple sensor systems. Its digital outputs are used to bias or reset the sensing elements.

APPLICATIONS

- Industrial pressure sensing
- Industrial temperature sensing
- Industrial chemical sensing
- Barometer
- Compass

FEATURES

- Up to 16-bit differential data acquisition
- Programmable gain: (1/12 to 1000)
- Sensor offset compensation up to 15 times full scale of input signal
- 1 differential or 2 single-ended signal inputs
- Programmable Resolution versus Speed versus Supply current
- Digital outputs to bias Sensors
- Internal or external voltage reference
- Internal time base
- Low-power (250 uA for 16b @ 250 S/s)
- Fast I2C interface with external address option, no clock stretching required

ORDERING INFORMATION

DEVICE	PACKAGE	REEL QUANTITY
SX8725CWLTDT	MLPD-W-12 4x4	1000

- Available in tape and reel only
- WEEE/RoHS compliant, Pb-Free and Halogen Free.

FUNCTIONAL BLOC DIAGRAM

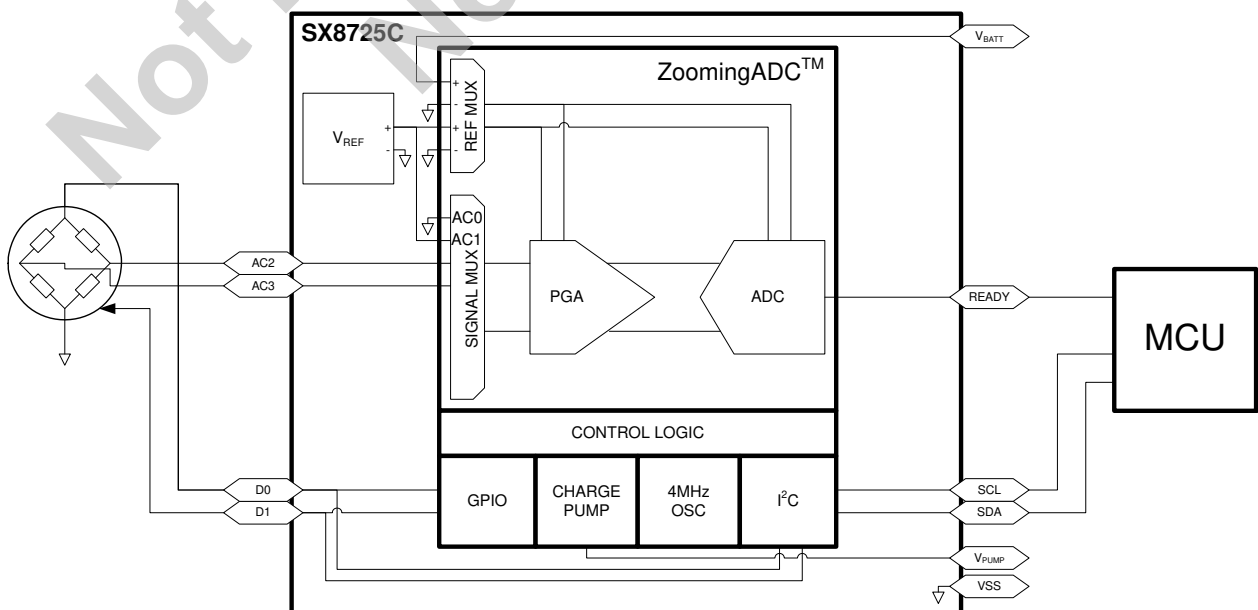

TABLE OF CONTENT

Section	Page
ELECTRICAL SPECIFICATIONS	4
1 Absolute Maximum Ratings	4
2 Operating Conditions	5
2.1 Timing Characteristics	9
2.1.1 POR Waveforms	9
2.1.2 I2C interface timings	10
2.1.3 I2C timing Waveforms	11
CIRCUIT DESCRIPTION	12
3 Pin Configuration	12
4 Marking Information	12
5 Pin Description	13
6 General Description	14
6.1 Bloc diagram	14
6.2 VREF	14
6.3 GPIO	15
6.3.1 Optional Operating Mode: External Vref	16
6.4 Charge Pump	17
6.5 RC Oscillator	17
6.5.1 Wake-up from sleep	17
7 ZoomingADC	18
7.1 Overview	18
7.1.1 Acquisition Chain	18
7.1.2 Programmable Gain Amplifiers	19
7.1.3 PGA & ADC Enabling	20
7.2 ZoomingADC Registers	20
7.3 Input Multiplexers (AMUX and VMUX)	21
7.4 First Stage Programmable Gain Amplifier (PGA1)	22
7.5 Second Stage Programmable Gain Amplifier (PGA2)	23
7.6 Third Stage Programmable Gain Amplifier (PGA3)	23
7.6.1 PGA Ranges	25
7.7 Analog-to-Digital Converter (ADC)	28
7.7.1 Conversion Sequence	28
7.7.2 Over-Sampling Frequency (fs)	29
7.7.3 Over-Sampling Ratio (OSR)	29
7.7.4 Number of Elementary Conversions (Nelconv)	29
7.7.5 Resolution	30
7.7.6 Conversion Time & Throughput	31
7.7.7 Continuous-Time vs. On-Request Conversion	32
7.7.8 Output Code Format	33
7.7.9 Power Saving Modes	35
8 Application hints	36
8.1 Power Reduction	36
8.2 Gain Configuration Flow	37
9 I2C Interface	38
9.1 General Features	38
9.2 Other Slave Address Options	38

TABLE OF CONTENT

Section	Page
9.2.1 Address Set Externally	39
9.3 I2C General Call Reset	39
9.4 I2C Register Access	40
9.4.1 Writing a Register	40
9.4.2 Reading in a Register	40
9.4.3 Writing in Several Consecutive Registers	40
9.4.4 Reading from Several Consecutive Registers	41
10 Register Memory Map and Description	42
10.1 Register Map	42
10.2 Registers Descriptions	42
10.2.1 RC Register	43
10.2.2 GPIO Registers	43
10.2.3 ZADC Registers	44
10.2.4 Mode Registers	46
11 Typical Performances	47
11.1 Input impedance	47
11.1.1 Switched Capacitor Principle	48
11.2 Frequency Response	49
11.3 Linearity	50
11.3.1 Integral Non-Linearity	50
11.3.2 Differential Non-Linearity	54
11.4 Noise	54
11.5 Gain Error and Offset Error	57
11.6 Power Consumption	58
 FAMILY OVERVIEW	 61
12 Comparizon table	61
13 Comparizon by package pinout	62
 MECHANICAL	 63
14 PCB Layout Considerations	63
15 How to Evaluate	63
16 Package Outline Drawing: 4x4MLPD-W12-EP1	64
17 Land Pattern Drawing: 4x4MLPD-W12-EP1	66
18 Tape and Reel Specification	67

ELECTRICAL SPECIFICATIONS
1 Absolute Maximum Ratings

Note The Absolute Maximum Ratings, in table below, are stress ratings only. Functional operation of the device at conditions other than those indicated in the Operating Conditions sections of this specification is not implied. Exposure to the absolute maximum ratings, where different to the operating conditions, for an extended period may reduce the reliability or useful lifetime of the product.

Table 1. Absolute Maximum Ratings

Parameter	Symbol	Condition	Min	Max	Units
Power supply	VBATT		V _{SS} - 0.3	6.5	V
Storage temperature	TSTORE		-55	150	°C
Temperature under bias	TBIAS		-40	140	°C
Input voltage	VINABS	All inputs	V _{SS} - 300	VBATT + 300	mV
Peak reflow temperature	TPKG			260	°C
ESD conditions	ESDHBM	Human Body Model ESD	2000		V
Latchup			100		mA

2 Operating Conditions

Unless otherwise specified: $V_{REF,ADC} = V_{BATT}$, $V_{IN} = 0V$, Over-sampling frequency $f_s = 250$ kHz, PGA3 on with Gain = 1, PGA1&PGA2 off, offsets $GDOFF2 = GDOFF3 = 0$. Power operation: normal ($I_{bAmpAdc[1:0]} = I_{bAmpPga[1:0]} = '01'$).

For resolution $n = 12$ bits: $OSR = 32$ and $NELCONV = 4$.

For resolution $n = 16$ bits: $OSR = 256$ and $NELCONV = 2$.

Bandgap chopped at $NELCONV$ rate. If $V_{BATT} < 4.2V$, Charge Pump is forced on. If $V_{BATT} > 4.2V$, Charge Pump is forced off.

Table 2. Operating conditions limits

Parameter	Symbol	Comment/Condition	Min	Typ	Max	Unit
Power supply	V_{BATT}		2.4		5.5	V
Operating temperature	TOP		-40		125	°C

Table 3. Electrical Characteristics

Parameter	Symbol	Comment/Condition	Min	Typ	Max	Unit
CURRENT CONSUMPTION¹						
Active current, 5.5V	IOP55	16 b @ 250 Sample/s ADC, $f_s = 125$ kHz		250	350	μA
		16 b @ 1kSample/s PGA3 + ADC, $f_s = 500$ kHz		700	900	
		16 b + gain 1000 @ 1kSample/s PGA3,2,1 + ADC, $f_s = 500$ kHz		1000	1350	
Active current, 3.3V	IOP33	16 b @ 250 Sample/s ADC, $f_s = 125$ kHz		150		μA
		16 b @ 1 kSample/s PGA3 + ADC, $f_s = 500$ kHz		300		
		16 b + gain 1000 @ 1kSample/s PGA3,2,1 + ADC, $f_s = 500$ kHz		850		
Sleep current	ISLEEP	@25°C		75		nA
		up to 85°C		100		
		@125°C		150	200	
TIME BASE						
Max ADC Over-Sampling frequency	f_{smax}	@25°C	425	500	575	kHz
ADC Over-Sampling frequency drift	f_{ST}			0.15		% / °C
DIGITAL I/O						
Input logic high	V_{IH}		0.7			V_{BATT}
Input logic low	V_{IL}				0.3	V_{BATT}
Output logic high	V_{OH}	$I_{OH} < 4$ mA			$V_{BATT}-0.4$	V
Output logic low	V_{OL}	$I_{OL} < 4$ mA	0.4			V
SCL and SDA I/O						
Input logic high	V_{IH}		0.7			V_{BATT}

Table 3. Electrical Characteristics

Parameter	Symbol	Comment/Condition	Min	Typ	Max	Unit
Input logic low	VIL				0.25	VBATT
Leakages currents						
Input leakage current	I _{LeakIn}	Digital input mode, no pull-up or pull-down	-100		100	nA
VREF: Internal Bandgap Reference						
Absolute output voltage	VBG	VBATT > 3V	1.19	1.22	1.25	V
Variation over Temperature	VBT	VBATT > 3V, over Temperature	-1.5		+1.5	%
Total Output Noise	VBN	VBATT > 3V			1	mVrms

- The device can be operated in either active or sleep states. The Sleep state is complete shutdown, but the active state can have a variety of different current consumptions depending on the settings. Some examples are given here: The Sleep state is the default state after power-on-reset. The chip can then be placed into an active state after a valid I2C communication is received.

Table 4. ZoomingADC Specifications

Parameter	Symbol	Condition	Min	Typ	Max	Unit
ANALOG INPUT CHARACTERISTICS						
Differential Input Voltage Range V _{IN} = V _{INP} -V _{INN}		Gain=1, OSR=32, VREF=5V. Note 1	-2.42		+2.42	V
		Gain=100, OSR=32, VREF=5V	-24.2		+24.2	mV
		Gain=1000, OSR=32, VREF=5V	-2.42		+2.42	mV
PROGRAMMABLE GAIN AMPLIFIER						
Total PGA Gain	GD _{TOT}	Note 1	1/12		1000	V/V
PGA1 Gain	GD ₁	(see Table 11, page 22)	1		10	V/V
PGA2 Gain	GD ₂	(see Table 12, page 23)	1		10	V/V
PGA3 Gain	GD ₃	Step = 1/12 V/V (see Table 13, page 23)	1/12		127/12	V/V
Gain Settings Precision (each stage)		Gain ≥ 1	-3	±0.5	+3	%
Gain Temperature Dependence				±5		ppm / °C
PGA2 Offset	GD _{OFF2}	Step = 0.2 V/V (see Table 12, page 23)	-1		+1	V/V
PGA3 Offset	GD _{OFF3}	Step = 1/12 V/V (see Table 13, page 23)	-63/12		+63/12	V/V
Offset Settings Precision (PGA2 or PGA3)		Note 2	-3	±0.5	+3	%
Offset Temperature Dependence				±5		ppm / °C
Input Impedance on PGA1 (see section 11.1, page 47)		Gain = 1. Note 3	1200	1350		kΩ
		Gain = 10. Note 3	250	300		kΩ
Input Impedance on PGA2,3		Gain = 1. Note 3	150	200		kΩ
Output RMS Noise per over-sample		PGA1. Note 4		205		μV
		PGA2. Note 4		340		μV
		PGA3. Note 4		365		μV

Table 4. ZoomingADC Specifications

Parameter	Symbol	Condition	Min	Typ	Max	Unit
ADC STATIC PERFORMANCES						
Resolution (No Missing Codes)	n	Note 5 Note 6	6		16	Bits
Gain Error		Note 7		±0.15		%
Offset Error		n = 16 bits. Note 8		±1		LSB
Integral Non-Linearity	INL	resolution n = 12 bits. Note 9		±0.6		LSB
		resolution n = 16 bits. Note 9		±1.5		LSB
Differential Non-Linearity	DNL	resolution n = 12 bits. Note 10		±0.5		LSB
		resolution n = 16 bits. Note 10		±0.5		LSB
Power Supply Rejection Ratio DC	PSRR	V _{BATT} = 5V +/- 0.3V. Note 11		78		dB
		V _{BATT} = 3V +/- 0.3V. Note 11		72		dB
ADC DYNAMIC PERFORMANCES						
Conversion Time	T _{CONV}	n = 12 bits. Note 12		133		fs cycles
		n = 16 bits. Note 12		517		fs cycles
Throughput Rate (Continuous Mode)	1/T _{CONV}	n = 12 bits, f _s = 250 kHz		1.88		kSps
		n = 16 bits, f _s = 250 kHz		0.483		kSps
PGA Stabilization Delay		Note 13 (see Table 12, page 23)		OSR		fs cycles
ZADC ANALOG QUIESCENT CURRENT						
ADC Only Consumption	I _Q	V _{BATT} = 5.5V/3.3V		285/210		µA
PGA1 Consumption		V _{BATT} = 5.5V/3.3V		104/80		µA
PGA2 Consumption		V _{BATT} = 5.5V/3.3V		67/59		µA
PGA3 Consumption		V _{BATT} = 5.5V/3.3V		98/91		µA
ANALOG POWER DISSIPATION : All PGAs & ADC Active						
Normal Power Mode		V _{BATT} = 5.5V/3.3V. Note 14		4.0/2.0		mW
3/4 Power Reduction Mode		V _{BATT} = 5.5V/3.3V. Note 15		3.2/1.6		mW
1/2 Power Reduction Mode		V _{BATT} = 5.5V/3.3V. Note 16		2.4/1.1		mW
1/4 Power Reduction Mode		V _{BATT} = 5.5V/3.3V. Note 17		1.5/0.7		mW

- (1) Gain defined as overall PGA gain $G_{TOT} = G_{D1} \times G_{D2} \times G_{D3}$. Maximum input voltage is given by: $V_{IN,MAX} = \pm(V_{REF} / 2) (OSR / OSR + 1)$.
- (2) Offset due to tolerance on G_{Doff2} or G_{Doff3} setting. For small intrinsic offset, use only ADC and PGA1.
- (3) Measured with block connected to inputs through A_{mux} block. Normalized input sampling frequency for input impedance is $f_s = 500$ kHz (f_s max, worst case). This figure must be multiplied by 2 for $f_s = 250$ kHz, 4 for $f_s = 125$ kHz. Input impedance is proportional to $1/f_s$.
- (4) Figure independent from gain and sampling frequency. f_s . The effective output noise is reduced by the over-sampling ratio
- (5) Resolution is given by $n = 2 \log_2(OSR) + \log_2(NELCONV)$. OSR can be set between 8 and 1024, in powers of 2. $NELCONV$ can be set to 1, 2, 4 or 8.
- (6) If a ramp signal is applied to the input, all digital codes appear in the resulting ADC output data.
- (7) Gain error is defined as the amount of deviation between the ideal (theoretical) transfer function and the measured transfer function (with the offset error removed).
- (8) Offset error is defined as the output code error for a zero volt input (ideally, output code = 0). For 1 LSB offset, $NELCONV$ must be at least 2.
- (9) INL defined as the deviation of the DC transfer curve of each individual code from the best-fit straight line. This specification holds over the full scale.
- (10) DNL is defined as the difference (in LSB) between the ideal (1 LSB) and measured code transitions for successive codes.
- (11) Values for Gain = 1. PSRR is defined as the amount of change in the ADC output value as the power supply voltage changes.

- (12) Conversion time is given by: $T_{CONV} = (N_{ELCONV}(OSR + 1) + 1) / f_s$. *OSR* can be set between 8 and 1024, in powers of 2. *NELCONV* can be set to 1, 2, 4 or 8.
- (13) PGAs are reset after each writing operation to registers **RegACCfg1-5**, corresponding to change of configuration or input switching. The ADC should be started only some delay after a change of PGA configuration through these registers. Delay between change of configuration of PGA or input channel switching and ADC start should be equivalent to *OSR* (between 8 and 1024) number of cycles. This is done by writing bit *Start* several cycles after *PGA* settings modification or channel switching. This delay does not apply to conversions made without the *PGAs*.
- (14) Nominal (maximum) bias currents in *PGAs* and *ADC*, i.e. $I_{bAmpPga}[1:0] = '11'$ and $I_{bAmpAdc}[1:0] = '11'$.
- (15) Bias currents in *PGAs* and *ADC* set to 3/4 of nominal values, i.e. $I_{bAmpPga}[1:0] = '10'$, $I_{bAmpAdc}[1:0] = '10'$.
- (16) Bias currents in *PGAs* and *ADC* set to 1/2 of nominal values, i.e. $I_{bAmpPga}[1:0] = '01'$, $I_{bAmpAdc}[1:0] = '01'$.
- (17) Bias currents in *PGAs* and *ADC* set to 1/4 of nominal values, i.e. $I_{bAmpPga}[1:0] = '00'$, $I_{bAmpAdc}[1:0] = '00'$.

Not Recommended for
New Designs

2.1 Timing Characteristics

Table 5. General timings

Parameter	Symbol	Comment/Condition	Min	Typ	Max	Unit
ADC INTERRUPT (READY) TIMING SPECIFICATIONS						
READY pulse width	t _{IRQ}	Note 1		1		1/fs
STARTUP TIMES						
Startup sequence time at POR	t _{START}				800	μs
Time to enable RC from Sleep after an I2C command	t _{RCEN}				450	μs

(1) The READY pulse indicates End of Conversion. This is a Positive pulse of duration equal to one cycle of the ADC sampling rate in “continuous mode”.

See also [Figure 17, page 33](#).

2.1.1 POR Waveforms

At device power-on or after a software reset

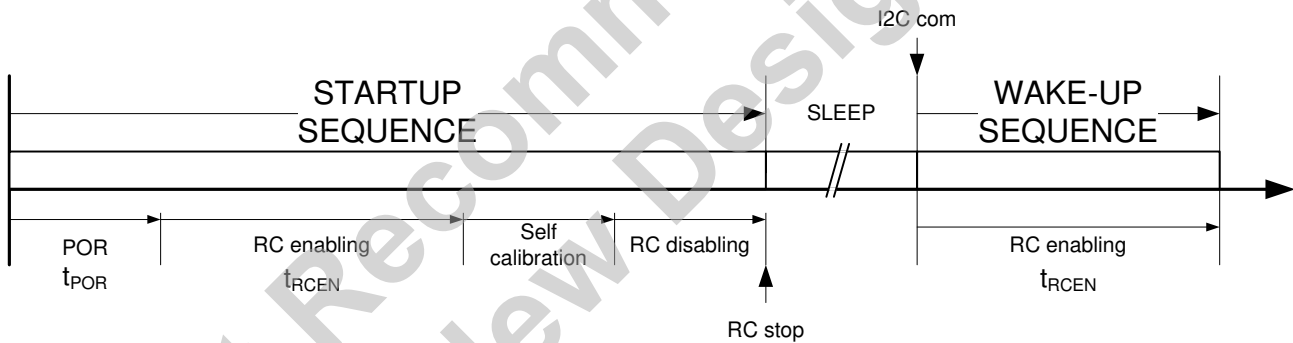

Figure 1. Power-On-Reset waveform

2.1.2 I2C interface timings
Table 6. Digital interface

Parameter	Symbol	STANDARD-MODE			FAST-MODE			Unit
		Min	Typ	Max	Min	Typ	Max	
I2C TIMING SPECIFICATIONS Note 1								
SCL clock frequency	fSCL	0		100	0		400	kHz
SCL timeout (optional mode) Note 2	tSCLTO	35			35			ms
SCL Low Pulsewidth	tL	4.7			1.3			μs
SCL High Pulsewidth	tH	4.0			0.6			μs
Start Condition Hold Time	tSCH	0.6			0.6			μs
Data Setup Time	tDS	250			100 Note 3			ns
Data Hold Time	tDH	0 Note 4		3.45	0		0.9	μs
Setup Time for Repeated Start	trSU	4.7			0.6			μs
Stop Condition Setup Time	tPSU	4.0			0.6			μs
Bus Free Time between a STOP Condition and a START Condition	tBF	4.7			1.3			μs
Pulsewidth of Spike Suppressed	tSUP		100			100		ns
Capacitive load for each bus line	CB			400			400	pF
Noise margin at the LOW level for each connected device (including hysteresis)	V _{nL}	0.1VBATT			0.1VBATT			V
Noise margin at the HIGH level for each connected device (including hysteresis)	V _{nH}	0.2VBATT			0.2VBATT			V

- (1) All timings specifications are referred to VILmin and VIHmax voltage levels defined for the SCL and SDA pins.
- (2) The digital interface is reset if the SCL is low more than tSCLTO duration. This is the default mode at startup. The timeout can be disabled by register setting.
- (3) A Fast-mode I2C-bus device can be used in a Standard-mode I2C-bus system.
- (4) The device internally provides a hold time of at least 300 ns for the SDA signal (referred to the VIHmin of the SCL signal) to bridge the undefined region of the falling edge of SCL.
- (5) Cb = total capacitance of one bus line in pF. If mixed with Hs-mode devices, faster fall-times according to Table 6 are allowed.

2.1.3 I2C timing Waveforms

Figure 2. Definition of timing for F/S-mode on the I2C-bus.

CIRCUIT DESCRIPTION

3 Pin Configuration

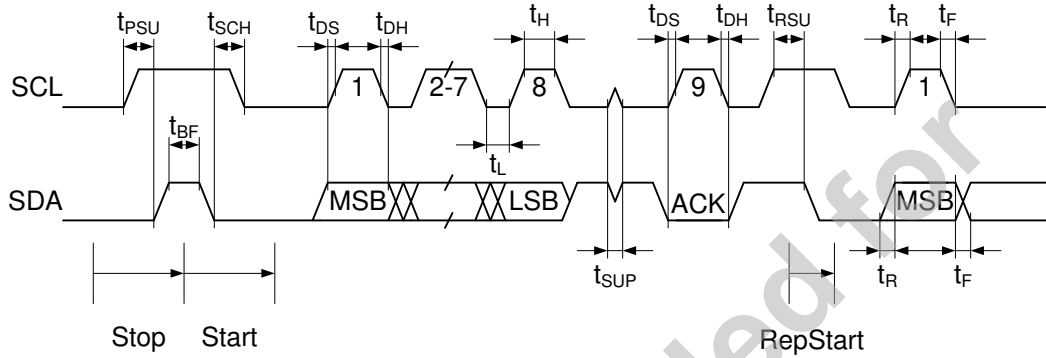
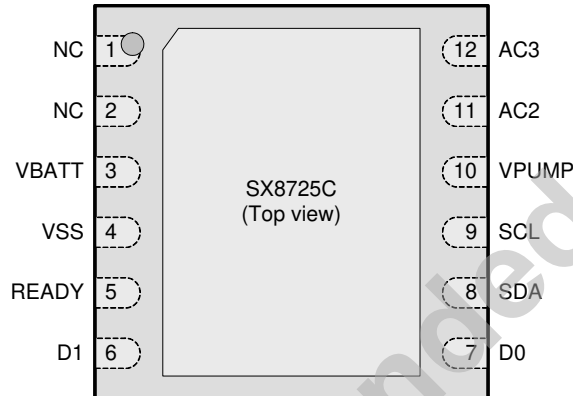

4 Marking Information



nnnnn = Part Number
 yyww = Date Code¹
 xxxxx = Semtech Lot Number
 xxxxx

1.Date codes and Lot numbers starting with the 'E' character are used for Engineering samples

5 Pin Description

Note The bottom pin is internally connected to VSS. It should also be connected to VSS on PCB to reduce noise and improve thermal behavior.

Pin	Name	Type	Function
1	N.C.	-	-
2	N.C.	-	-
3	VBATT	Power Input	2.4V to 5.5V power supply
4	VSS	Power Input	Chip Ground
5	READY	Digital Output	Conversion complete flag.
6	D1	Digital IO + analog input	Digital output sensor drive (VBATT or Vss)
			VREF input in optional operating mode
			I2C address bit 1. Msb address bits are fuse programmed.
7	D0	Digital IO + analog output	Digital output sensor drive (VBATT or Vss)
			VREF output in optional operating mode
			I2C address bit 0. Msb address bits are fuse programmed.
8	SDA	Digital IO	I2C data
9	SCL	Digital IO	I2C clock. Up to 400KHz.
10	VPUMP	Power IO	Charge pump output. Raises analog switch supply above VBATT if VBATT supply is too low. Recommended range for capacitor is 1nF to 10 nF. Connect the capacitor to ground.
11	AC2	Analog Input	Differential sensor input in conjunction with AC3
12	AC3	Analog Input	Differential sensor input in conjunction with AC2

6 General Description

The SX8725C is a complete low-power acquisition path with programmable gain, acquisition speed and resolution.

6.1 Bloc diagram

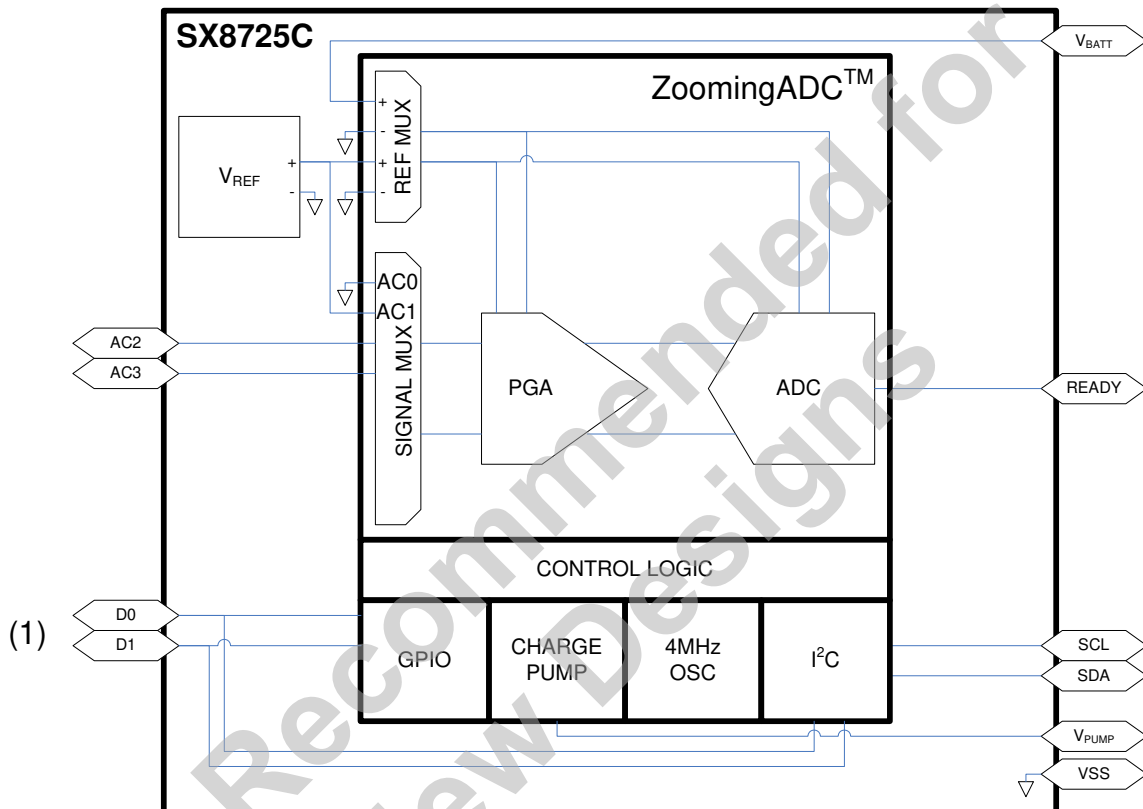

- (1) D0: digital IO, Vref output or I2C address select
 (1) D1: digital IO, Vref input or I2C address select

Figure 3. SX8725C bloc diagram

6.2 VREF

The internally generated V_{REF} is a trimmed bandgap reference with a nominal value of 1.22V that provides a stable voltage reference for the ZoomingADC.

This reference voltage is directly connected to one of the ZoomingADC reference multiplexer inputs.

The bandgap voltage stability is only guaranteed for V_{BATT} voltages of 3V and above. As V_{BATT} drops down to 2.4V, the bandgap voltage could reduce by up to 50mV.

The bandgap has relatively weak output drive so it is recommended that if the bandgap is required as a signal input then $PGA1$ must be enabled with gain = 1.

6.3 GPIO

The *GPIO* block is a multipurpose 2 bit input/output port. In addition to digital behavior, *D0* and *D1* pins can be programmed as analog pins in order to be used as output (reference voltage monitoring) and input for an external reference voltage (For further details see [Figure 6](#), [Figure 7](#), [Figure 8](#) and [Figure 9](#)). Each port terminal can be individually selected as digital input or output.

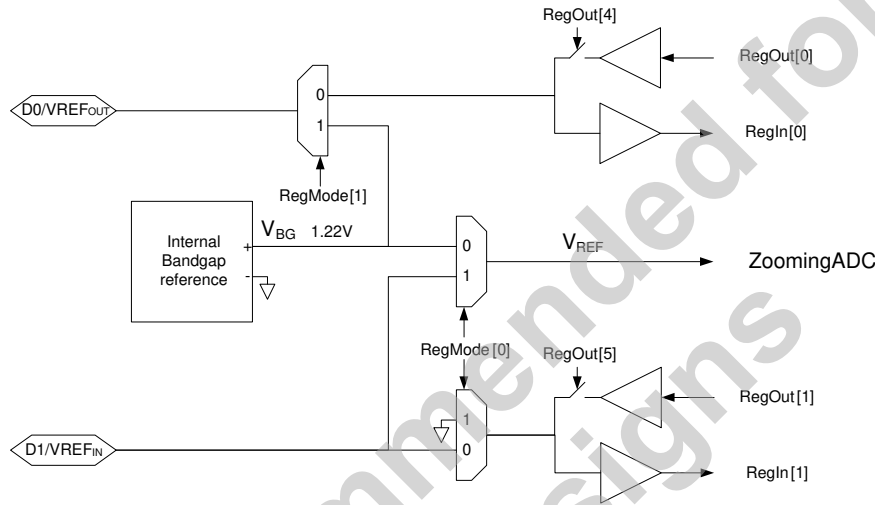

Figure 4. GPIO bloc diagram

The direction of each bit within the *GPIO* block (input only or input/output) can be individually set using the bits of the **RegOut** (address 0x40) register. If $D[x]Dir = 1$, both the input and output buffer are active on the corresponding *GPIO* block pin. If $D[x]Dir = 0$, the corresponding *GPIO* block pin is an input only and the output buffer is in high impedance. After power on reset the *GPIO* block pins are in input/output mode ($D[x]Dir$ are reset to 1).

The input values of *GPIO* block are available in **RegIn** (address 0x41) register (read only). Reading is always direct - there is no debounce function in the *GPIO* block. In case of possible noise on input signals, an external hardware filter has to be realized. The input buffer is also active when the *GPIO* block is defined as output and the effective value on the pin can be read back.

Data stored in the LSB bits of **RegOut** register are outputted at *GPIO* block if $D[x]Dir = 1$. The default values after power on reset is low (0).

The digital pins are able to deliver a driving current up to 8 mA.

When the bits $VrefD0Out$ and $VrefD1In$ in the **RegMode** (address 0x70) register are set to 1 the *D0* and *D1* pins digital behavior are automatically bypassed in order to either input or output the voltage reference signals.

6.3.1 Optional Operating Mode: External Vref

D0 and D1 are multi-functional pins with the following functions in different operating modes (see **RegMode** register for control settings):

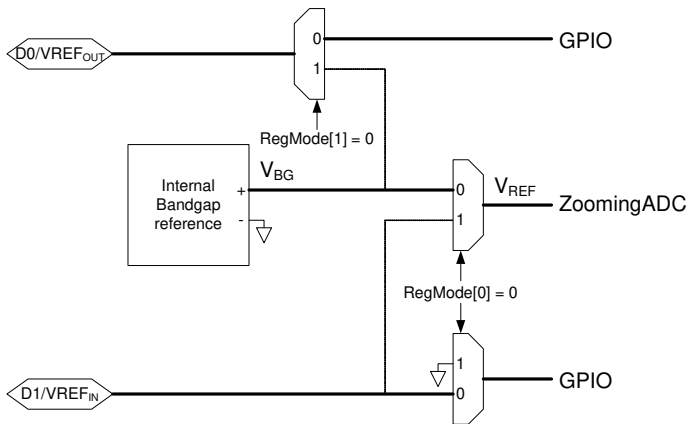

Figure 6. D0 and D1 are Digital Inputs / Outputs

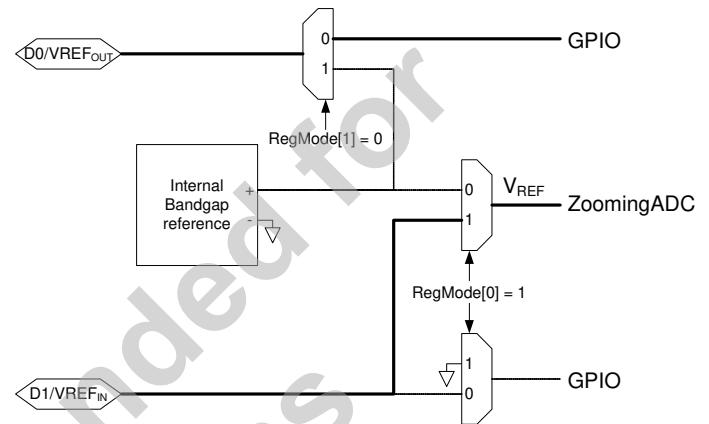

Figure 7. D1 is Reference Voltage Input and D0 is Digital Input / Output

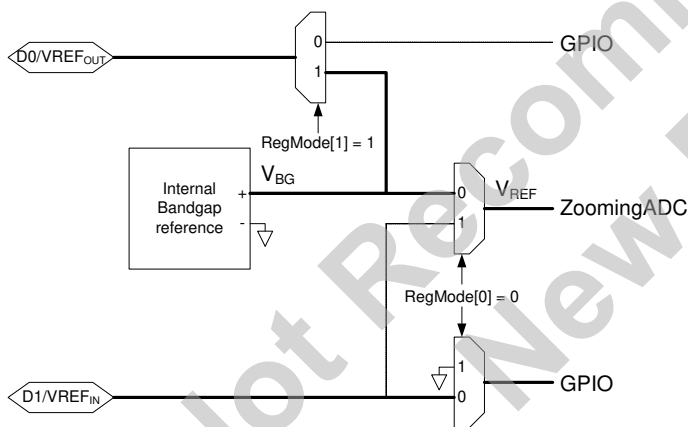

Figure 8. D1 is Digital Input / Output and D0 Reference Voltage Output

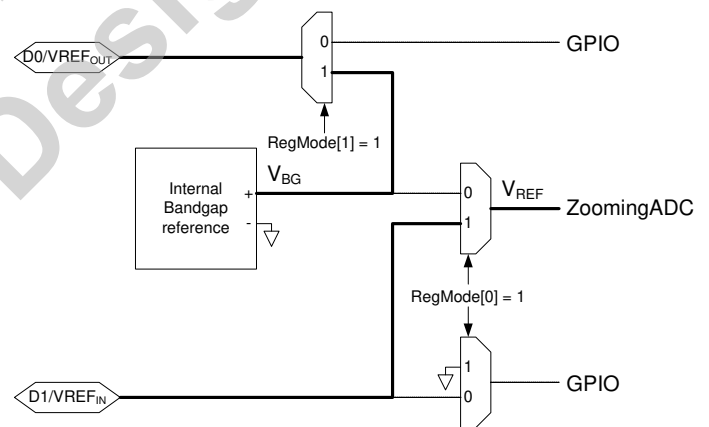

Figure 9. D0 is Reference Voltage Output and D1 is Reference Voltage Input

This allows external monitoring of the internal bandgap reference or the ability to use an external reference input for the ADC, or the option to filter the internal V_{REF} output before feeding back as $V_{REF,ADC}$ input. The internally generated V_{REF} is a trimmed as ADC reference with a nominal value of 1.22V. When using an external $V_{REF,ADC}$ input, it may have any value between 0V and V_{BATT} . Simply substitute the external value for 1.22 V in the ADC conversion calculations.

6.4 Charge Pump

This block generates a supply voltage able to power the analog switch drive levels on the chip higher than V_{BATT} if necessary.

If V_{BATT} voltage drops below 4.2V then the block should be activated. If V_{BATT} voltage is greater than 4.2V then V_{BATT} may be switched straight through to the $VPUMP$ output. If the charge pump is not activated then $VPUMP = V_{BATT}$.

If control input bit $MultForceOff = 1$ in **RegMode** (address 0x70) register then the charge pump is disabled and V_{BATT} is permanently connected to $VPUMP$ output.

If control input bit $MultForceOn = 1$ in **RegMode** register then the charge pump is permanently enabled. This overrides $MultForceOff$ bit in **RegMode** register.

An external capacitor is required on $VPUMP$ pin. This capacitor should be large enough to ensure that generated voltage is smooth enough to avoid affecting conversion accuracy but not so large that it gives an unacceptable settling time. A recommended value is around 2.2nF.

6.5 RC Oscillator

This block provides the master clock reference for the chip. It produces a clock at 4 MHz which is divided internally in order to generate the clock sources needed by the other blocks.

The oscillator technique is a low power relaxation design and it is designed to vary as little as possible over temperature and supply voltage.

This oscillator is trimmed at manufacture chip test.

The RC oscillator will start up after a chip reset to allow the trimming values to be read and calibration registers and I2C address set to their default fused values. Once this has been done, the oscillator will be shut down and the chip will enter a sleep state while waiting for an I2C communication.

The worst case duration from reset (or POR) to the sleep state is 800us.

6.5.1 Wake-up from sleep

When the device is in sleep state, the RC oscillator will start up after a communication. The start up sequence for the RC oscillator is 450us in worst case.

During this time, the internal blocs using the RC can not be used: no ADC conversion can be started.

7 ZoomingADC

7.1 Overview

The *ZoomingADC* is a complete and versatile low-power analog front-end interface typically intended for sensing applications. In the following text the *ZoomingADC* will be referred as *ZADC*.

The key features of the *ZADC* are:

- Programmable 6 to 16-bit dynamic range over-sampled ADC
- Flexible gain programming between 1/12 and 1000
- Flexible and large range offset compensation
- Differential or single-ended input
- 2-channel differential reference inputs
- Power saving modes

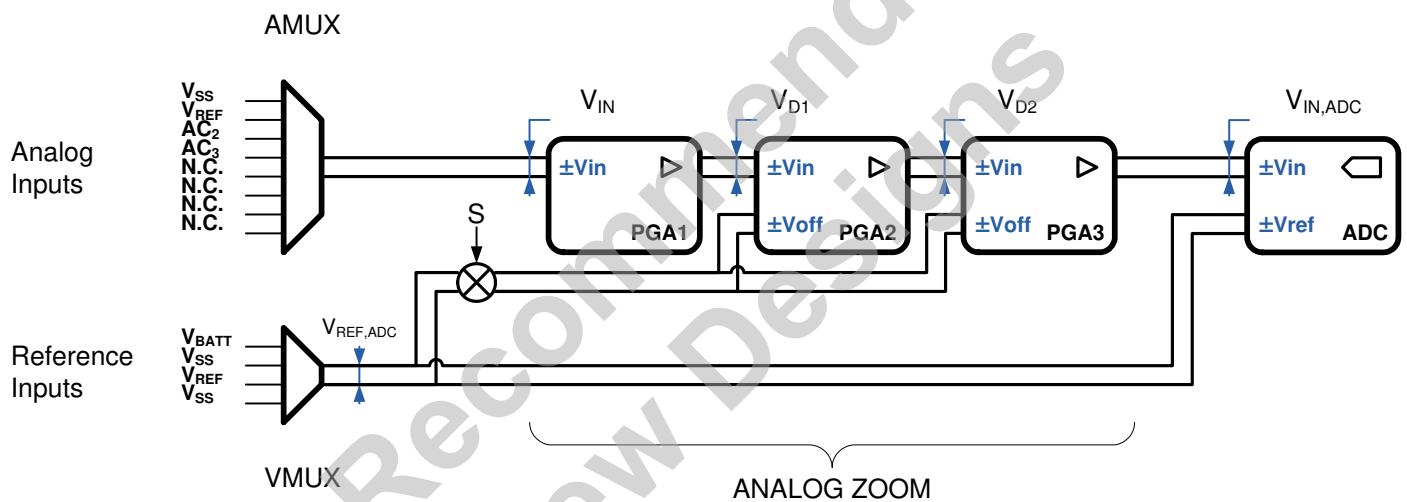

Figure 10. ZADC General Functional Block Diagram

The total acquisition chain consists of an input multiplexer, 3 programmable gain amplifier stages and an over sampled A/D converter. The reference voltage can be selected on two different channels. Two offset compensation amplifiers allow for a wide offset compensation range. The programmable gain and offset allow the application to zoom in on a small portion of the reference voltage defined input range.

7.1.1 Acquisition Chain

Figure 10, page 18 shows the general block diagram of the acquisition chain (AC). A control block (not shown in **Figure 10**) manages all communications with the I2C peripheral. The clocking is derived from the internal 4 MHz Oscillator.

Analog inputs can be selected through an 8 input multiplexer, while reference input is selected between two differential channels. It should however be noted that only 7 acquisition channels (including the VREF) are available when configured as single ended since the input amplifier is always operating in differential mode with both positive and negative input selected through the multiplexer.

The core of the zooming section is made of three differential programmable amplifiers (*PGA*). After selection of an input and reference signals V_{IN} and $V_{REF,ADC}$ combination, the input voltage is modulated and amplified through stages 1 to 3. Fine gain programming up to 1'000 V/V is possible. In addition, the last two stages provide programmable offset. Each amplifier can be bypassed if needed.

The output of the cascade of *PGA* is directly fed to the analog-to-digital converter (*ADC*), which converts the signal $V_{IN,ADC}$ into digital.

Like most *ADCs* intended for instrumentation or sensing applications, the ZoomingADC™ is an over-sampled converter¹. The *ADC* is a so-called incremental converter; with bipolar operation (the *ADC* accepts both positive and negative differential input voltages). In first approximation, the *ADC* output result relative to full-scale (*FS*) delivers the quantity:

$$\frac{OUT_{ADC}}{FS/2} \cong \frac{V_{IN,ADC}}{V_{REF}/2}$$

Equation 1

in two's complement (see [Equation 18](#) and [Equation 19](#), page 33 for details). The output code OUT_{ADC} is $-FS/2$ to $+FS/2$ for $V_{IN,ADC} = -V_{REF,ADC}/2$ to $+V_{REF,ADC}/2$ respectively. As will be shown, $V_{IN,ADC}$ is related to input voltage V_{IN} by the relationship:

$$V_{IN,ADC} = GD_{TOT} \cdot V_{IN} - GD_{Off,TOT} \cdot S \cdot V_{REF} \quad [V]$$

Equation 2

where GD_{TOT} is the total *PGA* gain, $GD_{Off,TOT}$ is the total magnitude of *PGA* offset and S is the sign of the offset (see [Table 9](#), page 21).

7.1.2 Programmable Gain Amplifiers

As seen in [Figure 10](#), page 18, the zooming function is implemented with three programmable gain amplifiers (*PGA*). These are:

- *PGA1*: coarse gain tuning
- *PGA2*: medium gain and offset tuning
- *PGA3*: fine gain and offset tuning. Should be set ON for high linearity data acquisition

All gain and offset settings are realized with ratios of capacitors. The user has control over each *PGA* activation and gain, as well as the offset of stages 2 and 3. These functions are examined hereafter.

1. Over-sampled converters are operated with a sampling frequency f_s much higher than the input signal's Nyquist rate (typically f_s is 20-1'000 times the input signal bandwidth). The sampling frequency to throughput ratio is large (typically 10-500). These converters include digital decimation filtering. They are mainly used for high resolution, and/or low-to-medium speed applications.

7.1.3 PGA & ADC Enabling

Depending on the application objectives, the user may enable or bypass each *PGA* stage. This is done according to the word *Enable* and the coding given in **Table 7**. To reduce power dissipation, the *ADC* can also be inactivated while idle.

Table 7. ADC and PGA Enabling

Enable (RegACCfg1[3:0])	Block
XXX0 XXX1	ADC disabled ADC enabled
XX0X XX1X	PGA1 disabled PGA1 enabled
X0XX X1XX	PGA2 disabled PGA2 enabled
0XXX 1XXX	PGA3 disabled PGA3 enabled

7.2 ZoomingADC Registers

The system has a bank of eight 8-bit registers: six registers are used to configure the acquisition chain (**RegAcCfg0** to **RegAcCfg5**), and two registers are used to store the output code of the analog-to-digital conversion (**RegAcOutMsb** & **Lsb**).

Table 8. Peripheral Registers to Configure the Acquisition Chain (AC) and to Store the Analog-to-Digital Conversion (ADC) Result

Register Name	Bit position							
	7	6	5	4	3	2	1	0
RegACOutLsb	Out[7:0] Note 1							
RegACOutMsb	Out[15:8]							
RegACCfg0 Default values:	Start 0, Note 2	SetNelconv 01, Note 3		SetOsr 010, Note 4			Continuous 0, Note 5	- 0, Note 6
RegACCfg1 Default value:	IbAmpAdc 11, Note 7		IbAmpPga 11, Note 8		Enable 0000, Note 9			
RegACCfg2 Default value:	SetFs 00, Note 10		Pga2Gain 00, Note 12		Pga2Offset 0000, Note 14			
RegACCfg3 Default value:	Pga1Gain 0, Note 11	Pga3Gain 0001100, Note 13						
RegACCfg4 Default value:	- 0	Pga3Offset 0000000, Note 15						
RegACCfg5 Default value:	Busy 0, Note 16	Def 0, Note 17	Amux 00000, Note 18				Vmux 0, Note 19	

(r = read; w = write; rw = read & write)

- (1) **Out:** (r) digital output code of the analog-to-digital converter. (*MSB* = *Out*[15])
- (2) **Start:** (w) setting this bit triggers a single conversion (after the current one is finished). This bit always reads back 0.

- (3) **SetNelconv:** (rw) sets the number of elementary conversions to $2^{(SetNelconv[1:0])}$. To compensate for offsets, the input signal is chopped between elementary conversions (1,2,4,8).
- (4) **SetOsr:** (rw) sets the over-sampling rate (OSR) of an elementary conversion to $2^{(3+SetOsr[2:0])}$. OSR = 8, 16, 32, ..., 512, 1024.
- (5) **Continuous:** (rw) setting this bit starts a conversion. When this bit is 1, A new conversion will automatically begin directly when the previous one is finished.
- (6) Reserved
- (7) **IbAmpAdc:** (rw) sets the bias current in the ADC to $0.25 \times (1 + IbAmpAdc[1:0])$ of the normal operation current (25, 50, 75 or 100% of nominal current). To be used for low-power, low-speed operation.
- (8) **IbAmpPga:** (rw) sets the bias current in the PGAs to $0.25 \times (1 + IbAmpPga[1:0])$ of the normal operation current (25, 50, 75 or 100% of nominal current). To be used for low-power, low-speed operation.
- (9) **Enable:** (rw) enables the ADC modulator (bit 0) and the different stages of the PGAs (PGA_i by bit i=1,2,3). PGA stages that are disabled are bypassed.
- (10) **SetFs:** (rw) These bits set the over sampling frequency of the acquisition chain. Expressed as a fraction of the oscillator frequency, the sampling frequency is given as: 11 ' 500 kHz, 10 ' 250 kHz, 01 ' 125 kHz, 00 ' 62.5 kHz.
- (11) **Pga1Gain:** (rw) sets the gain of the first stage: 0 ' 1, 1 ' 10.
- (12) **Pga2Gain:** (rw) sets the gain of the second stage: 00 ' 1, 01 ' 2, 10 ' 5, 11 ' 10.
- (13) **Pga3Gain:** (rw) sets the gain of the third stage to Pga3Gain[6:0] 1/12.
- (14) **Pga2Offset:** (rw) sets the offset of the second stage between -1 and +1, with increments of 0.2. The MSB gives the sign (0 positive, 1 negative); amplitude is coded with the bits Pga2Offset[5:0].
- (15) **Pga3Offset:** (rw) sets the offset of the third stage between -5.25 and +5.25, with increments of 1/12. The MSB gives the sign (0 positive, 1 negative); amplitude is coded with the bits Pga3Offset[5:0].
- (16) **Busy:** (r) set to 1 if a conversion is running.
- (17) **Def:** (w) sets all values to their defaults (PGA disabled, max speed, nominal modulator bias current, 2 elementary conversions, over-sampling rate of 32) and starts a new conversion without waiting the end of the preceding one.
- (18) **Amux(4:0):** (rw) Amux[4] sets the mode (0 ' differential inputs, 1 ' single ended inputs with A0= common reference) Amux[3] sets the sign (0 ' straight, 1 ' cross) Amux[2:0] sets the channel.
- (19) **Vmux:** (rw) sets the differential reference channel (0 ' V_{BATT}, 1 ' V_{REF}).

7.3 Input Multiplexers (AMUX and VMUX)

The ZoomingADC has analog inputs AC0 to AC3 and reference inputs. Let us first define the differential input voltage *V_{IN}* and reference voltage *V_{REF,ADC}* respectively as:

$$V_{IN} = V_{INP} - V_{INN} \quad [V]$$

Equation 3

$$V_{REF} = V_{REFP} - V_{REFN} \quad [V]$$

Equation 4

As shown in **Table 9**, the inputs can be configured in two ways: either as 4 differential channels (*V_{IN1}*= AC1 - AC0, *V_{IN2}*= AC3 - AC2), or AC0 can be used as a common reference, providing 7 signal paths all referred to AC0. The control word for the analog input selection is *Amux*. Notice that the *Amux* bit 4 controls the sign of the input voltage.

Table 9. Analog Input Selection

Amux (RegACCfg5[5:1])	V _{INP}	V _{INN}	Amux (RegACCfg5[5:1])	V _{INP}	V _{INN}
Sign S = 1			Sign S = -1		
00x00	AC1(V _{REF})	AC0(V _{SS})	01x00	AC1(V _{SS})	AC0(V _{REF})

Table 9. Analog Input Selection

Amux (RegACCFg5[5:1])	VINP	VINN	Amux (RegACCFg5[5:1])	VINP	VINN
Sign S = 1			Sign S = -1		
00x01	AC3	AC2	01x01	AC2	AC3
00x10	N.C.	N.C.	01x10	N.C.	N.C.
00x11	N.C.	N.C.	01x11	N.C.	N.C.
10000	AC0(Vss)	AC0(Vss)	11000	AC0(Vss)	AC0(Vss)
10001	AC1(VREF)		11001		AC1(VREF)
10010	AC2		11010		AC2
10011	AC3		11011		AC3
10100	N.C.		11100		N.C.
10101	N.C.		11101		N.C.
10110	N.C.		11110		N.C.
10111	N.C.		11111		N.C.

Similarly, the reference voltage is chosen among two differential channels ($V_{REF} = V_{BATT} - V_{SS}$, $V_{REF} = V_{BG} - V_{SS}$ or $V_{REF} = V_{REF,IN} - V_{SS}$) as shown in [Table 10](#). The selection bit is V_{mux} . The reference inputs V_{REFP} and V_{REFN} (common-mode) can be up to the power supply range.

Table 10. Analog reference Input Selection

Vmux (RegACCFg5[0])	VREFP	VREFN
0	$V_{REF} = V_{BATT}$	VSS
1	$V_{REF} = V_{BG}$ or $V_{REF,IN}^1$	VSS

1. External voltage reference on D1 GPIO pin. See [section 6.3 on page 15](#) about GPIO and "RegMode[0x70]" on page 46.

7.4 First Stage Programmable Gain Amplifier (PGA1)

The first stage can have a buffer function (unity gain) or provide a gain of 10 (see [Table 11](#)). The voltage V_{D1} at the output of $PGA1$ is:

$$V_{D1} = GD_1 \cdot V_{IN} \quad [V]$$

Equation 5

where GD_1 is the gain of $PGA1$ (in V/V) controlled with the $Pga1Gain$ bit.

Table 11. PGA1 gain settings

Pga1Gain bit (RegACCFg3[7])	PGA1 gain [V/V] GD_1 [V/V]
0	1
1	10

7.5 Second Stage Programmable Gain Amplifier (PGA2)

The second *PGA* has a finer gain and offset tuning capability, as shown in [Table 12](#). The V_{D2} voltage at the output of *PGA2* is given by:

$$V_{D2} = GD_2 \cdot V_{D1} - GD_{off2} \cdot S \cdot V_{REF} \quad [V]$$

Equation 6

where GD_2 and GD_{OFF2} are respectively the gain and offset of *PGA2* (in V/V). These are controlled with the words *Pga2Gain[1:0]* and *Pga2Offset[3:0]*.

Table 12. PGA2 gain and offset settings

Pga2Gain bitfield (RegACCfg2[5:4])	PGA2 gain [V/V] GD_2 [V/V]	Pga2Offset bitfield (RegACCfg2[3:0])	PGA2 offset GD_{OFF2} [V/V]
00	1	0000	0
01	2	0001	+0.2
10	5	0010	+0.4
11	10	0011	+0.6
		0100	+0.8
		0101	+1
		1000	0
		1001	-0.2
		1010	-0.4
		1011	-0.6
		1100	-0.8
		1101	-1.0

7.6 Third Stage Programmable Gain Amplifier (PGA3)

The finest gain and offset tuning is performed with the third and last *PGA* stage, according to the coding of [Table 13](#).

Table 13. PGA3 Gain and Offset Settings

Pga3Gain bitfield (RegACCfg3[6:0])	PGA3 Gain GD_3 [V/V]	Pga3Offset bitfield (RegACCfg4[6:0])	PGA3 Offset GD_{OFF3} [V/V]
0000000	0	0000000	0
0000001	1/12 (=0.083)	0000001	+1/12 (=0.083)
...
0000110	6/12	0010000	+16/12
...
0001100	12/12	0100000	32/12
0010000	16/12
...	...	0111111	+63/12 (=+5.25)
0100000	32/12	1000000	0

Table 13. PGA3 Gain and Offset Settings

Pga3Gain bitfield (RegACCfg3[6:0])	PGA3 Gain GD_3 [V/V]	Pga3Offset bitfield (RegACCfg4[6:0])	PGA3 Offset $GDOff_3$ [V/V]
...	...	1000001	-1/12 (= -0.083)
1000000	64/12	1000010	-2/12
...
1111111	127/12 (=10.58)	1010000	-16/12
	
		1100000	-32/12
	
		1111111	-63/12 (= -5.25)

The output of PGA_3 is also the input of the ADC. Thus, similarly to PGA_2 , we find that the voltage entering the ADC is given by:

$$V_{IN,ADC} = GD_3 \cdot V_{D2} - GDOff_3 \cdot S \cdot V_{REF} \quad [V]$$

Equation 7

where GD_3 and $GDOff_3$ are respectively the gain and offset of PGA_3 (in V/V). The control words are $Pga3Gain[6:0]$ and $Pga3Offset[6:0]$.

To remain within the signal compliance of the PGA stages (no saturation), the condition:

$$|V_{IN}|, |V_{D1}|, |V_{D2}| < \frac{V_{BATT}}{2}$$

Equation 8

must be verified.

To remain within the signal compliance of the ADC (no saturation), the condition:

$$|V_{IN,ADC}| < \left(\frac{V_{REF}}{2} \right) \left(\frac{OSR - 1}{OSR} \right)$$

Equation 9

must be verified.

Finally, combining **Equation 5** to **Equation 7** for the three *PGA* stages, the input voltage $V_{IN,ADC}$ of the *ADC* is related to V_{IN} by:

$$V_{IN,ADC} = GD_{TOT} \cdot V_{IN} - GDoff_{TOT} \cdot S \cdot V_{REF} \quad [V]$$

Equation 10

where the total *PGA* gain is defined as:

$$GD_{TOT} = GD_3 \cdot GD_2 \cdot GD_1$$

Equation 11

and the total *PGA* offset is:

$$GDoff_{TOT} = GDoff_3 + GD_3 \cdot GDoff_2$$

Equation 12

7.6.1 *PGA* Ranges

Figure 11 and **Figure 12** illustrates the limits for the maximal conversion precision according to the common mode voltage (V_{COMMON}), the *ADC* over-sampling frequency (f_s) and *PGA* gains. The best linearity performances can be