

Chipsmall Limited consists of a professional team with an average of over 10 year of expertise in the distribution of electronic components. Based in Hongkong, we have already established firm and mutual-benefit business relationships with customers from,Europe,America and south Asia,supplying obsolete and hard-to-find components to meet their specific needs.

With the principle of “Quality Parts,Customers Priority,Honest Operation,and Considerate Service”,our business mainly focus on the distribution of electronic components. Line cards we deal with include Microchip,ALPS,ROHM,Xilinx,Pulse,ON,Everlight and Freescale. Main products comprise IC,Modules,Potentiometer,IC Socket,Relay,Connector.Our parts cover such applications as commercial,industrial, and automotives areas.

We are looking forward to setting up business relationship with you and hope to provide you with the best service and solution. Let us make a better world for our industry!



Contact us

Tel: +86-755-8981 8866 Fax: +86-755-8427 6832

Email & Skype: info@chipsmall.com Web: www.chipsmall.com

Address: A1208, Overseas Decoration Building, #122 Zhenhua RD., Futian, Shenzhen, China

WIRELESS & SENSING

GENERAL DESCRIPTION

The SX9500 is a low-cost, very low power 4-channel capacitive controller that can operate either as a proximity or button sensor. The SX9500 includes sophisticated on-chip auto-calibration circuitry to regularly perform sensitivity adjustments, maintaining peak performance over a wide variation of temperature, humidity and noise environments, providing simplified product development and enhanced performance.

The SX9500 operates directly from an input supply voltage of 2.7 to 5.5V, and includes a separate I2C serial bus supply input to enable communication with 1.8 – 5.5V hosts. The I2C serial communication bus reports proximity or touch detection and is used to facilitate parameter settings adjustment. Upon a proximity detection, the NIRQ output asserts, enabling the user to either determine the relative proximity distance, or simply obtain an indication of detection.

A dedicated transmit enable (TXEN) pin is available to synchronize capacitive measurements for applications that require synchronous detection, enabling very low supply current and high noise immunity by only measuring proximity when requested.

KEY PRODUCT FEATURES

- ◆ **2.7 – 5.5V Input Supply Voltage**
- ◆ **Capacitive Sensor Inputs**
 - ❖ Down to 0.08 fF Capacitance Resolution
 - ❖ Stable Proximity & Touch Sensing With Temperature
 - ❖ Capacitance Offset Compensation to 30pF
- ◆ **Active Sensor Guarding**
- ◆ **Automatic Calibration**
- ◆ **Ultra Low Power Consumption:**
 - ❖ Active Mode: 170 uA
 - ❖ Doze Mode: 18 uA
 - ❖ Sleep Mode: 2.5 uA
- ◆ **400KHz I2C Serial Interface**
 - ❖ Four programmable I2C Sub-Addresses
 - ❖ Input Levels Compatible with 1.8V Host Processors
- ◆ **Open Drain NIRQ Interrupt pin**
- ◆ **Three (3) Reset Sources: POR, NRST pin, Soft Reset**
- ◆ **-40°C to +85°C Operation**
- ◆ **Compact Size: 3 x 3mm Thin QFN package**
- ◆ **Pb & Halogen Free, RoHS/WEEE compliant**

APPLICATIONS

- Notebooks
- Tablets
- Mobile Appliances

ORDERING INFORMATION

Part Number	Package	Marking
SX9500IULTRT ¹	QFN-20	ZND8
SX9500EVKA	Eval. Kit	

¹ 3000 Units/reel

TYPICAL APPLICATION CIRCUIT

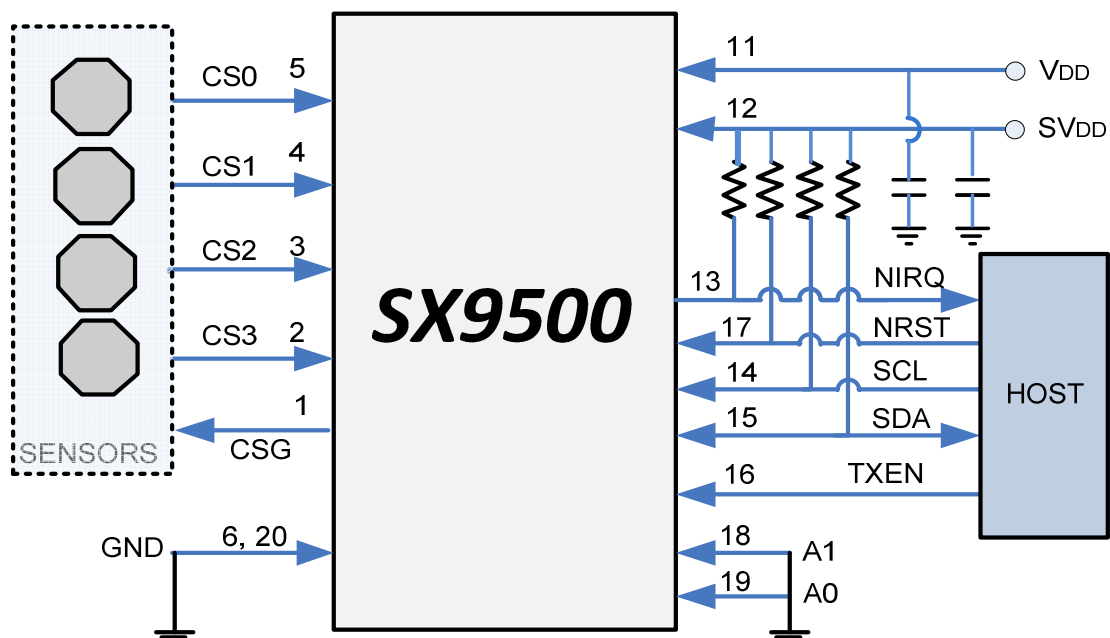
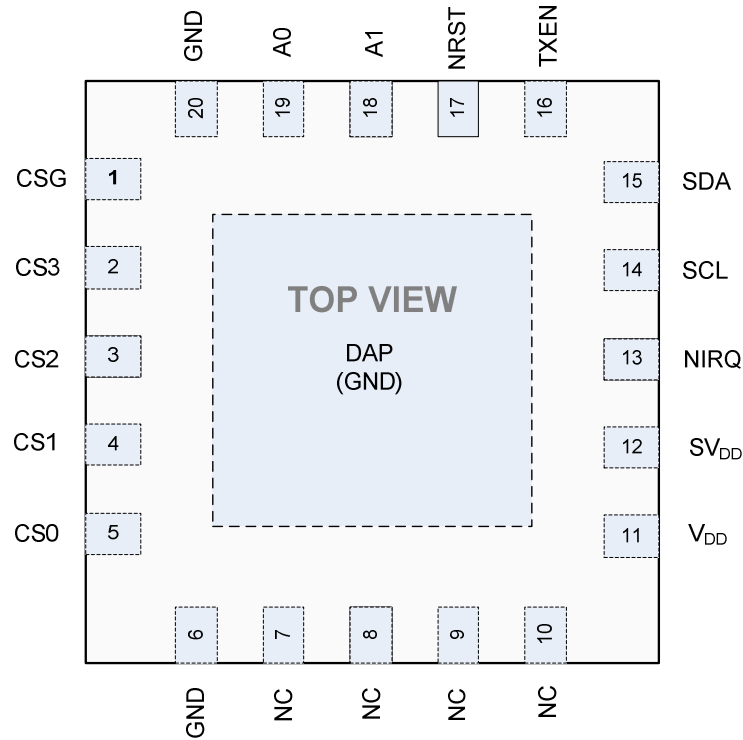
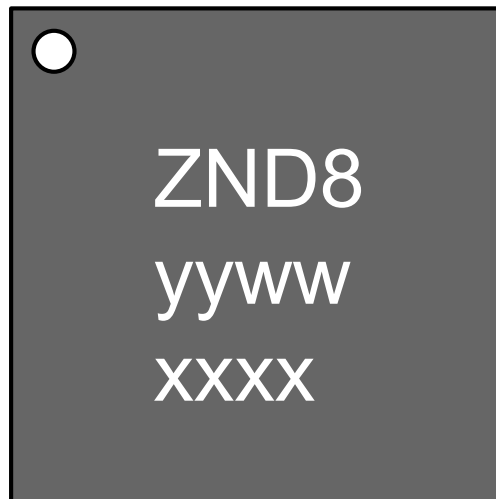

Table of Contents

GENERAL DESCRIPTION.....	1
KEY PRODUCT FEATURES.....	1
APPLICATIONS.....	1
ORDERING INFORMATION.....	1
TYPICAL APPLICATION CIRCUIT	1
1 GENERAL DESCRIPTION.....	4
1.1 Pin Diagram	4
1.2 Marking Information	4
1.3 Pin Description	5
1.4 Acronyms	5
2 ELECTRICAL CHARACTERISTICS	6
2.1 Absolute Maximum Ratings	6
2.2 Operating Conditions	6
2.3 Thermal Characteristics	6
2.4 Electrical Specifications	7
3 PROXIMITY SENSING INTERFACE.....	9
3.1 Introduction	9
3.2 Scan Period	9
3.3 Analog Front-End (AFE)	10
3.3.1 Capacitive Sensing Basics	10
3.3.2 AFE Block Diagram	12
3.3.3 Capacitance-to-Voltage Conversion (C-to-V)	12
3.3.4 Shield Control	12
3.3.5 Offset Compensation	12
3.3.6 Analog-to-Digital Conversion (ADC)	13
3.4 Digital Processing	13
3.4.1 Overview	13
3.4.2 PROXRAW Update	15
3.4.3 PROXUSEFUL Update	15
3.4.4 PROXAVG Update	16
3.4.5 PROXDIFF Update	18
3.4.6 PROXSTAT Update	18
3.5 Host Operation	19
3.6 Operational Modes	20
3.6.1 Active	20
3.6.2 Doze	20
3.6.3 Sleep	20
3.6.4 TXEN Pin	20
4 I2C INTERFACE.....	21
4.1 Introduction	21
4.2 I2C Write	21
4.3 I2C Read	21
5 RESET.....	23
5.1 Power-up	23
5.2 NRST Pin	23
5.3 Software Reset	24
6 INTERRUPT	25

WIRELESS & SENSING

6.1	Power-up	25
6.2	Assertion and Clearing	25
7	PINS DESCRIPTION	26
7.1	V _{DD} and SV _{DD}	26
7.2	TXEN	26
7.3	Capacitive Sensing Interface (CS0, CS1, CS2, CS3, CSG)	26
7.4	Host Interface	26
7.4.1	NIRQ	26
7.4.2	SCL, NRST and TXEN	27
7.4.3	SDA	27
8	REGISTERS	28
8.1	Overview	28
8.2	Detailed Description	29
9	APPLICATION INFORMATION	33
9.1	Typical Application Circuit	33
9.2	External Components Recommended Values	33
10	PACKAGING INFORMATION	34
10.1	Outline Drawing	34
10.2	Land Pattern	35

WIRELESS & SENSING
1 GENERAL DESCRIPTION
1.1 Pin Diagram

Figure 1: Pin Diagram
1.2 Marking Information

yyww = Date Code
 xxxx = Lot Number

Figure 2: Marking Information

1.3 Pin Description

Number	Name	Type	Description
1	CSG	Analog	Capacitive Sensor Guard/Shield
2	CS3	Analog	Capacitive Sensor 3
3	CS2	Analog	Capacitive Sensor 2
4	CS1	Analog	Capacitive Sensor 1
5	CS0	Analog	Capacitive Sensor 0
6	GND	Ground	Ground
7	NC	Not Used	Do Not Connect
8	NC	Not Used	Do Not Connect
9	NC	Not Used	Do Not Connect
10	NC	Not Used	Do Not Connect
11	V _{DD}	Power	Core power supply
12	SV _{DD}	Power	Host interface power supply. Must be ≤V _{DD} at all times (including during power-up and power-down)
13	NIRQ	Digital Output	Interrupt request, active LOW, requires pull-up resistor to SV _{DD}
14	SCL	Digital Input	I2C Clock, requires pull-up resistor to SV _{DD}
15	SDA	Digital I/O	I2C Data, requires pull-up resistor to SV _{DD}
16	TXEN	Digital Input	Transmit Enable, active HIGH (Tie to SV _{DD} if not used).
17	NRST	Digital Input	External reset, active LOW (Tie to SV _{DD} if not used).
18	A1	Digital Input	I2C Sub-Address, connect to GND or V _{DD}
19	A0	Digital Input	I2C Sub-Address, connect to GND or V _{DD}
20	GND	Ground	Ground
DAP	GND	Ground	Exposed Pad. Connect to Ground

Table 1: Pin Description

1.4 Acronyms

DAP Die Attach Paddle
 RF Radio Frequency

2 ELECTRICAL CHARACTERISTICS

2.1 Absolute Maximum Ratings

Stresses above the values listed in “Absolute Maximum Ratings” may cause permanent damage to the device. This is a stress rating only and functional operation of the device at these, or any other conditions beyond the “Operating Conditions”, is not implied. Exposure to Absolute Maximum Rating conditions for extended periods may affect device reliability and proper functionality.

Parameter	Symbol	Min	Max	Unit
Supply Voltage	V _{DD}	-0.5	6.0	V
	SV _{DD}	-0.5	6.0	
Input Voltage (non-supply pins)	V _{IN}	-0.5	V _{DD} +0.3	
Input Current (non-supply pins)	I _{IN}	-10	10	mA
Operating Junction Temperature	T _{JCT}	-40	125	°C
Reflow Temperature	T _{RE}	-	260	
Storage Temperature	T _{STOR}	-50	150	
ESD HBM (Human Body model, to JESD22-A114)	ESD _{HBM}	8	-	kV

Table 2: Absolute Maximum Ratings

2.2 Operating Conditions

Parameter	Symbol	Min	Max	Unit
Supply Voltage	V _{DD}	2.7	5.5	V
	SV _{DD}	1.65	V _{DD}	
Ambient Temperature	T _A	-40	85	°C

Table 3: Operating Conditions

Note: During power-up or power-down, SV_{DD} must be less than or equal to V_{DD}

2.3 Thermal Characteristics

Parameter	Symbol	Typical	Unit
Thermal Resistance – Junction to Air (Static Airflow)	θ _{JA}	34	°C/W

Table 4: Thermal Characteristics

Note: θ_{JA} is calculated from a package in still air, mounted to 3" x 4.5", 4-layer FR4 PCB with thermal vias under exposed pad per JESD51 standards.

WIRELESS & SENSING
2.4 Electrical Specifications

All values are valid within the operating conditions unless otherwise specified.

Typical values are given for $T_A = +25^\circ\text{C}$, $V_{DD} = SV_{DD} = 3.3\text{V}$ unless otherwise specified.

Parameter	Symbol	Conditions	Min	Typ	Max	Unit
Current Consumption						
Sleep (no sensor enabled)	I_{SLEEP}	Power down, all analog circuits shut down. (I2C listening)	-	2.5	-	uA
Doze (all sensors enabled)	I_{DOZE}	SCANPERIOD = 200ms DOZEPERIOD = 2xSCANPERIOD FREQ = 167kHz RESOLUTION = Medium VDD = 5V	-	18	-	
Active (all sensors enabled)	I_{ACTIVE}	SCANPERIOD = 30ms FREQ = 167kHz RESOLUTION = Medium VDD = 5V	-	170	-	
Outputs: SDA, NIRQ						
Output Current at Output Low Voltage	I_{OL}	$V_{\text{OL}} = 0.4\text{V}$	6	-	-	mA
Maximum Output LOW Voltage	$V_{\text{OL(Max)}}$	$SV_{\text{DD}} > 2\text{V}$	-	-	0.4	V
		$SV_{\text{DD}} \leq 2\text{V}$	-	-	$0.2 \times SV_{\text{DD}}$	
Inputs: SCL, SDA, TXEN						
Input logic high	V_{IH}		$0.8 \times SV_{\text{DD}}$	-	$SV_{\text{DD}} + 0.3$	V
Input logic low	V_{IL}		-0.3	-	$0.25 \times SV_{\text{DD}}$	
Input leakage current	I_{L}	CMOS input	-1	-	1	uA
Hysteresis	V_{HYS}	$SV_{\text{DD}} > 2\text{V}$	-	$0.05 \times SV_{\text{DD}}$	-	V
		$SV_{\text{DD}} \leq 2\text{V}$	-	$0.1 \times SV_{\text{DD}}$	-	
TXEN Delay	$\text{TXEN}_{\text{ACTDLY}}$	Delay between TXEN rising edge and SX9500 starting measurements	-	100	-	μs
Inputs: A0, A1						
Input logic high	V_{IH}		$0.7 \times V_{\text{DD}}$	-	$V_{\text{DD}} + 0.3$	V
Input logic low	V_{IL}		-0.3	-	$0.3 \times V_{\text{DD}}$	
Input: NRST						
Input logic high	V_{IH}	$SV_{\text{DD}} > 2\text{V}$	$0.7 \times SV_{\text{DD}}$	-	$SV_{\text{DD}} + 0.3$	V
		$SV_{\text{DD}} \leq 2\text{V}$	$0.75 \times SV_{\text{DD}}$	-		
Input logic low	V_{IL}	$SV_{\text{DD}} > 2\text{V}$	-	-	0.6	
		$SV_{\text{DD}} \leq 2\text{V}$	-	-	$0.3 \times SV_{\text{DD}}$	
NRST minimum pulse width	T_{RESETPW}		2	-	-	μs
Start-up						
Power-up time	T_{POR}		-	1	-	ms

Table 5: Electrical Specifications

WIRELESS & SENSING

Parameter	Symbol	Conditions	Min	Typ	Max	Unit
I2C Timing Specifications (Cf. Figure 3 and Figure 4 below)						
SCL clock frequency	f_{SCL}		-	-	400	kHz
SCL low period	t_{LOW}		1.3	-	-	us
SCL high period	t_{HIGH}		0.6	-	-	
Data setup time	$t_{SU;DAT}$		0.1	-	-	
Data hold time	$t_{HD;DAT}$		0	-	-	
Repeated start setup time	$t_{SU;STA}$		0.6	-	-	
Start condition hold time	$t_{HD;STA}$		0.6	-	-	
Stop condition setup time	$t_{SU;STO}$		0.6	-	-	
Bus free time between stop and start	t_{BUF}		1.3	-	-	
Input glitch suppression	t_{SP}	Note 1	-	-	50	

Note 1: Minimum glitch amplitude is $0.7V_{DD}$ at High level and Maximum $0.3V_{DD}$ at Low level.

Table 6: I2C Timing Specifications

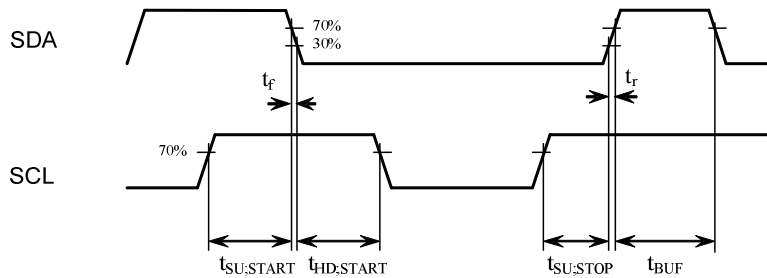

Figure 3: I2C Start and Stop Timing

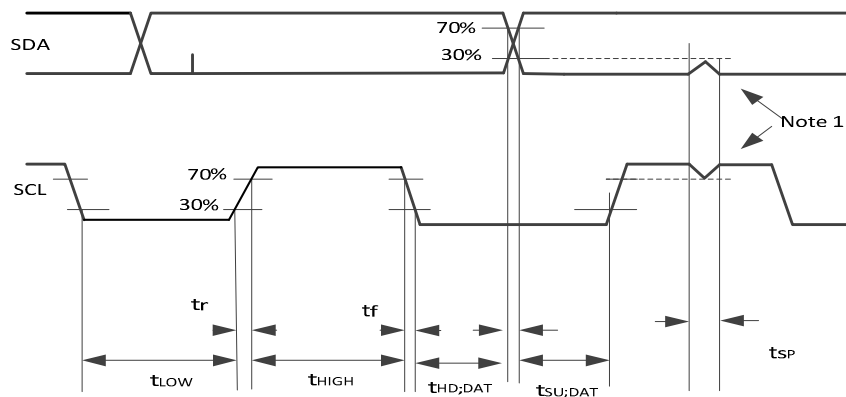

Figure 4: I2C Data Timing

3 PROXIMITY SENSING INTERFACE

3.1 Introduction

The purpose of the proximity sensing interface is to detect when a conductive object (usually a body part i.e. finger, palm, face, etc) is in the proximity of the system. Note that proximity sensing can be done thru the air or thru a solid (typically plastic) overlay (also called “touch” sensing).

The chip’s proximity sensing interface is based on capacitive sensing technology. An overview is given in figure below.

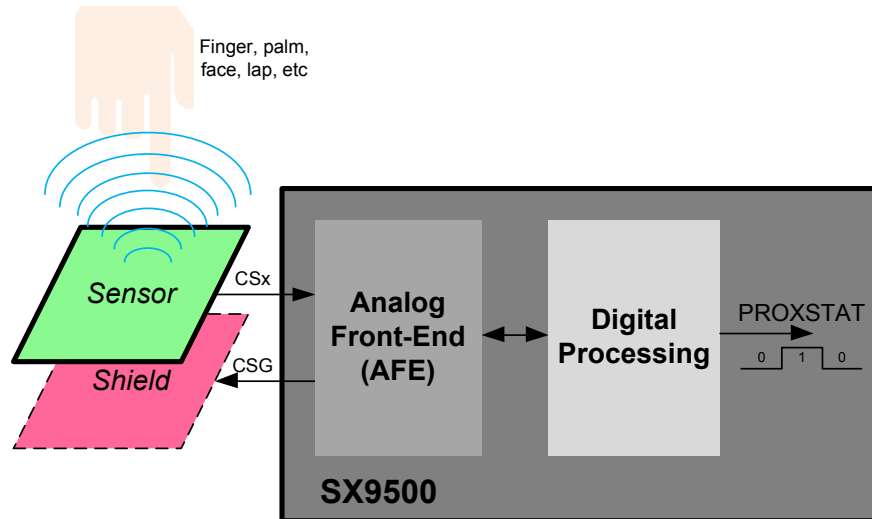

Figure 5: Proximity Sensing Interface Overview

- ❖ The sensor can be a simple copper area on a PCB or FPC for example. Its capacitance (to ground) will vary when a conductive object is moving in its proximity.
- ❖ The optional shield can be also be a simple copper area on a PCB or FPC below/under/around the sensor. It is used to protect the sensor against potential surrounding noise sources and improve its global performance. It also brings directivity to the sensing, for example sensing objects approaching from top only.
- ❖ The analog front-end (AFE) performs the raw sensor’s capacitance measurement and converts it into a digital value. It also controls the shield. See §3.3 for more details.
- ❖ The digital processing block computes the raw capacitance measurement from the AFE and extracts a binary information PROXSTAT corresponding to the proximity status, i.e. object is “Far” or “Close”. It also triggers AFE operations (compensation, etc). See §3.4 for more details.

3.2 Scan Period

To save power and since the proximity event is slow by nature, the chip will be waken-up regularly at every programmed scan period (SCANPERIOD) to first sense sequentially each of the enabled CSx pins and then process new proximity samples/info. The chip will be in idle mode most of the time. This is illustrated in figure below

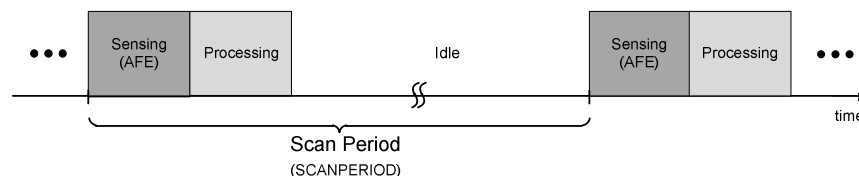

Figure 6: Proximity Sensing Sequencing

WIRELESS & SENSING

The sensing and processing phase's durations vary with the number of sensors enabled, the sampling frequency, and the resolution programmed. During the Idle phase, the SX9500's analog circuits are turned off. Upon expiry of the idle timer, a new scan period cycle begins.

The scan period determines the minimum reaction time (actual/final reaction time also depends on debounce and filtering settings) and can be programmed from 30ms to 400ms.

3.3 Analog Front-End (AFE)

3.3.1 Capacitive Sensing Basics

Capacitive sensing is the art of measuring a small variation of capacitance in a noisy environment. As mentioned above, the chip's proximity sensing interface is based on capacitive sensing technology. In order to illustrate some of the user choices and compromises required when using this technology it is useful to understand its basic principles.

To illustrate the principle of capacitive sensing we will use the simplest implementation where the sensor is a copper plate on a PCB.

The figure below shows a cross-section and top view of a typical capacitive sensing implementation. The sensor connected to the chip is a simple copper area on top layer of the PCB. It is usually surrounded (shielded) by ground for noise immunity (shield function) but also indirectly couples via the grounds areas of the rest of the system (PCB ground traces/planes, housing, etc). For obvious reasons (design, isolation, robustness ...) the sensor is stacked behind an overlay which is usually integrated in the housing of the complete system.

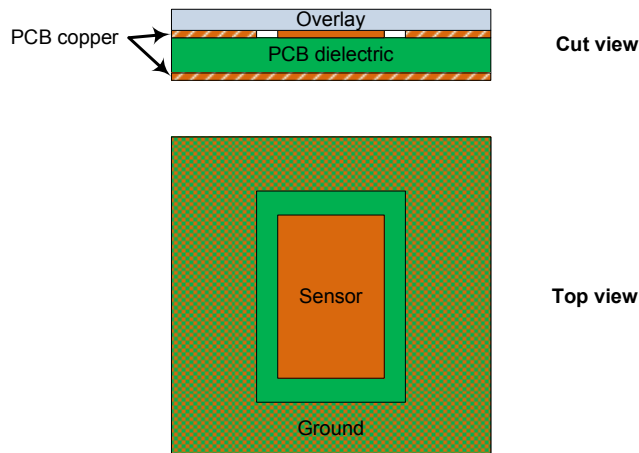

Figure 7: Typical Capacitive Sensing Implementation

When the conductive object to be detected (finger/palm/face, etc) is not present, the sensor only sees an inherent capacitance value C_{Env} created by its electrical field's interaction with the environment, in particular with ground areas.

When the conductive object (finger/palm/face, etc) approaches, the electrical field around the sensor will be modified and the total capacitance seen by the sensor increased by the user capacitance C_{User} . This phenomenon is illustrated in the figure below.

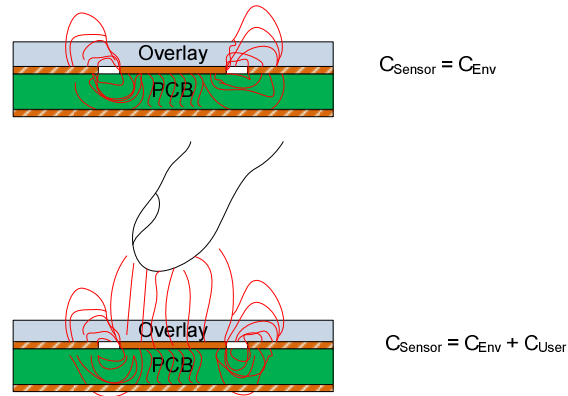

Figure 8: Proximity Effect on Electrical Field and Sensor Capacitance

The challenge of capacitive sensing is to detect this relatively small variation of C_{Sensor} (C_{User} usually contributes for a few percent only) and differentiate it from environmental noise (C_{Env} also slowly varies together with the environment characteristics like temperature, etc). For this purpose, the chip integrates an auto offset compensation mechanism which dynamically monitors and removes the C_{Env} component to extract and process C_{User} only. See §3.3.5 for more details.

In first order, C_{User} can be estimated by the formula below:

$$C_{\text{User}} = \frac{\epsilon_0 \cdot \epsilon_r \cdot A}{d}$$

A is the common area between the two electrodes hence the common area between the user's finger/palm/face and the sensor.

d is the distance between the two electrodes hence the proximity distance between the user and the system.

ϵ_0 is the free space permittivity and is equal to $8.85 \cdot 10^{-12}$ F/m (constant)

ϵ_r is the dielectric relative permittivity.

Typical permittivity of some common materials is given in the table below.

Material	Typical ϵ_r
Glass	8
FR4	5
Acrylic Glass	3
Wood	2
Air	1

Table 7: Typical Permittivity of Some Common Materials

From the discussions above we can conclude that the most robust and efficient design will be the one that minimizes C_{Env} value and variations while improving C_{User} .

WIRELESS & SENSING
3.3.2 AFE Block Diagram

Figure 9: Analog Front-End Block Diagram

3.3.3 Capacitance-to-Voltage Conversion (C-to-V)

The sensitivity of the interface is defined by RANGE and GAIN parameters.

PROXFREQ defines the operating frequency of the interface and should be set as high as possible for power consumption reasons.

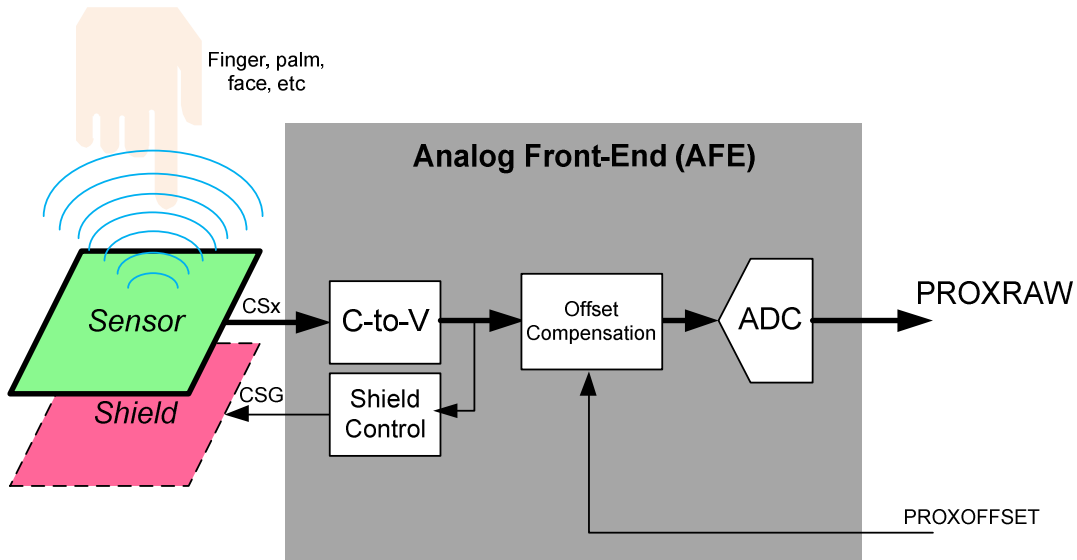
3.3.4 Shield Control

SHIELDEN allows enabling or disabling the shield function.

3.3.5 Offset Compensation

Offset compensation consists in performing a one-time measurement of C_{Env} and subtracting it to the total capacitance C_{Sensor} in order to feed the ADC with the closest contribution of C_{User} only.

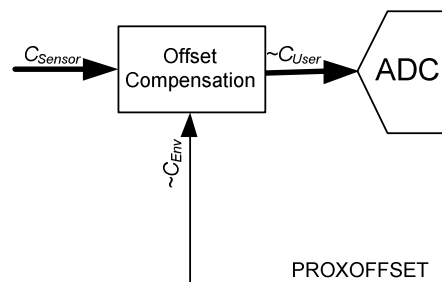

Figure 10: Offset Compensation Block Diagram

The ADC input C_{User} is the total capacitance C_{Sensor} to which C_{Env} is subtracted.

WIRELESS & SENSING

There are five possible compensation sources which are illustrated in the figure below. When set to 1 by any of these sources, COMPSTAT will only be reset once the compensation is completed.

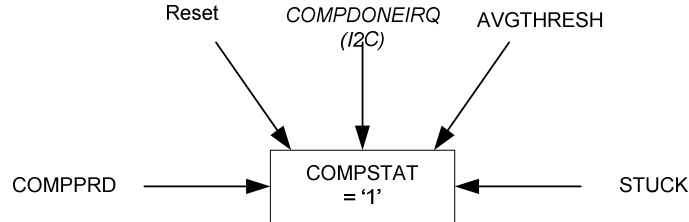

Figure 11: Compensation Request Sources

- **Reset:** a compensation for all sensors is automatically requested when a reset is performed (power-up, NRST pin, RegReset)
- **COMPDONEIRQ (I2C):** a compensation for all sensors can be manually requested anytime by the host through I2C interface by writing a 1 into COMPDONEIRQ.
- **AVGTHRESH:** a compensation for all sensors or only the affected one (depending on COMPMETHOD) can be automatically requested if it is detected that C_{Env} has drifted beyond a predefined range programmed by the host.
- **COMPPRD:** a compensation can be automatically requested at a predefined rate programmed by the host.
- **STUCK:** a compensation can be automatically requested if it is detected that the proximity “Close” state lasts longer than a predefined duration programmed by the host.

Please note that the compensation request flag can be set anytime but the compensation itself is always done at the beginning of a scan period to keep all parameters coherent. Also, when compensation occurs, all PROXSTAT flags turn OFF (ie no proximity detected) independently from the user’s potential actual presence.

3.3.6 Analog-to-Digital Conversion (ADC)

An ADC is used to convert the analog capacitance information into a digital word PROXRAW.

3.4 Digital Processing

3.4.1 Overview

The main purpose of the digital processing block is to convert the raw capacitance information coming from the AFE (PROXRAW) into a robust and reliable digital flag (PROXSTAT) indicating if something is close to the proximity sensor.

The offset compensation performed in the AFE is a one-time measurement. However, the environment capacitance C_{Env} may vary with time (temperature, nearby objects, etc). Hence, in order to get the best estimation of C_{User} (PROXDIFF) it is needed to dynamically track and subtract C_{Env} variations. This is performed by filtering PROXUSEFUL to extract its slow variations (PROXAVG).

PROXDIFF is then compared to user programmable threshold (PROXTHRESH) to extract PROXSTAT flag.

WIRELESS & SENSING

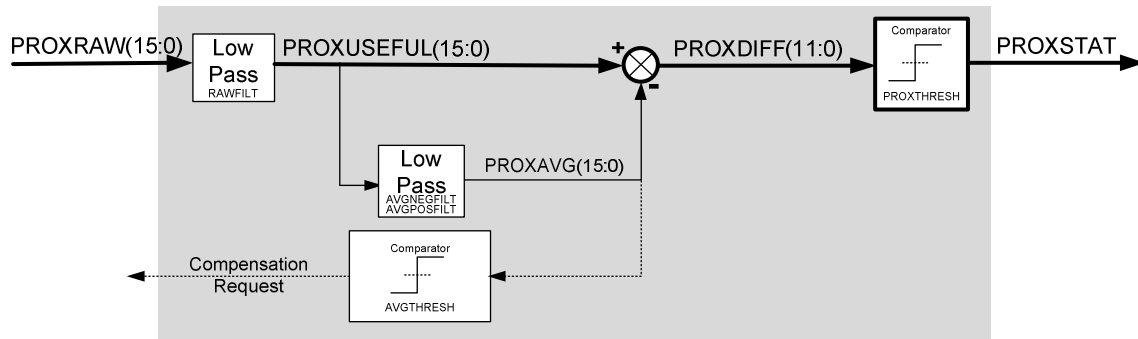

Figure 12: Digital Processing Block Diagram

Digital processing sequencing is illustrated in figure below. At every scan period wake-up, the block updates sequentially PROXRRAW, PROXUSEFUL, PROXAVG, PROXDIFF and PROXSTAT before going back to Idle mode.

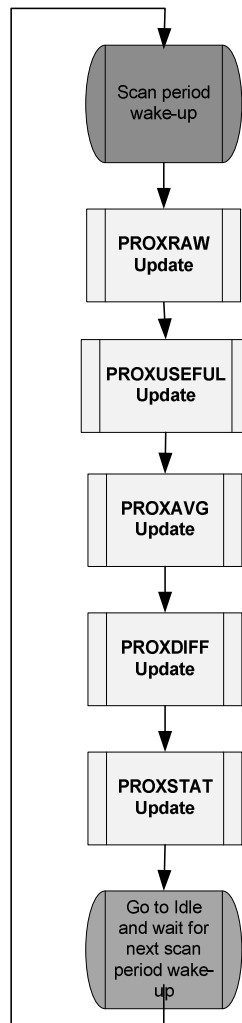

Figure 13: Digital Processing Sequencing

Digital processing block also updates COMPSTAT (set when compensation is currently pending execution or completion)

WIRELESS & SENSING
3.4.2 PROXRAW Update

PROXRAW update consists mainly in starting the AFE and waiting for the new PROXRAW values (one for each CSx/sensor pin) to be ready. If compensation was pending it is performed first.

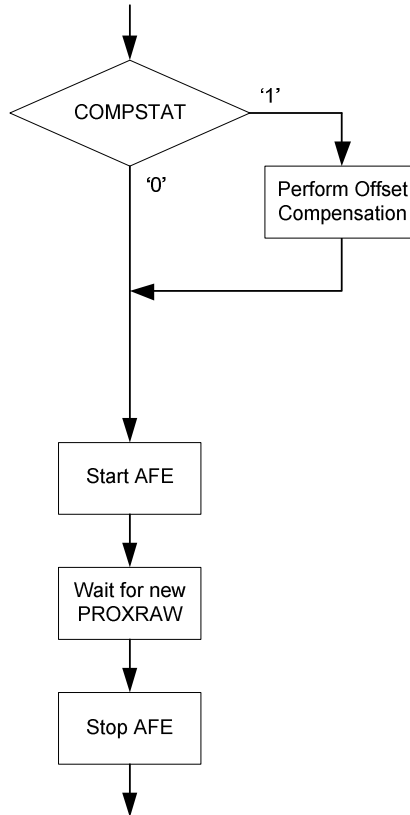

Figure 14: ProxRaw Update

Note that PROXRAW is not available in the “Sensor Data Readback” section of the registers. If needed it can be observed by setting RAWFILT=00 and reading PROXUSEFUL.

3.4.3 PROXUSEFUL Update

PROXUSEFUL update consists in filtering PROXRAW upfront to remove its potential high frequencies components(system noise, interferer, etc) and extract only user activity (few Hz max) and slow environment changes.

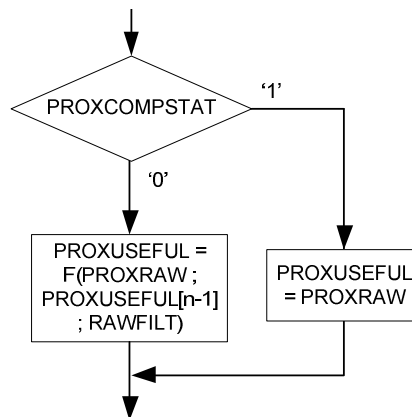

Figure 15: PROXUSEFUL Update

3.4.4 PROXAVG Update

PROXAVG update consists in averaging PROXUSEFUL to ignore its “fast” variations (i.e. user finger/palm/hand) and extract only the very slow variations of environment capacitance C_{Env} .

One can program a debounced threshold (AVGTHRESH/AVGDEB) to define a range within which PROXAVG can vary without triggering compensation (i.e. small acceptable environment drift).

Large positive values of PROXUSEFUL are considered as normal (user finger/hand/head) but large negative values are considered abnormal and should be compensated quickly. For this purpose, the averaging filter coefficient can be set independently for positive and negative variations via AVGPOSFILT and AVGNEGFILT. Typically we have $AVGPOSFILT > AVGNEGFILT$ to filter out (abnormal) negative events faster.

To prevent PROXAVG to be “corrupted” by user activity (should only reflect environmental changes) it is frozen when proximity is detected.

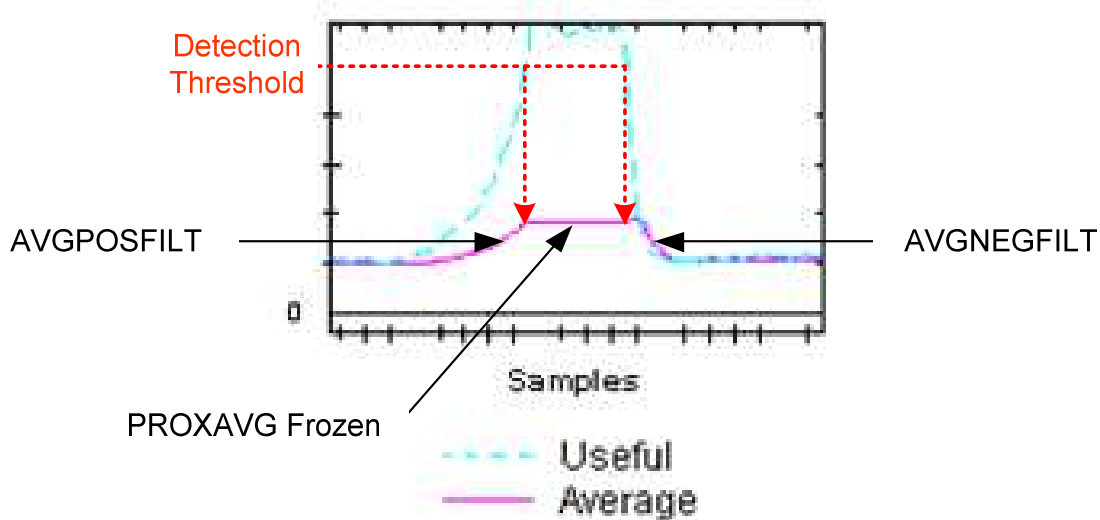
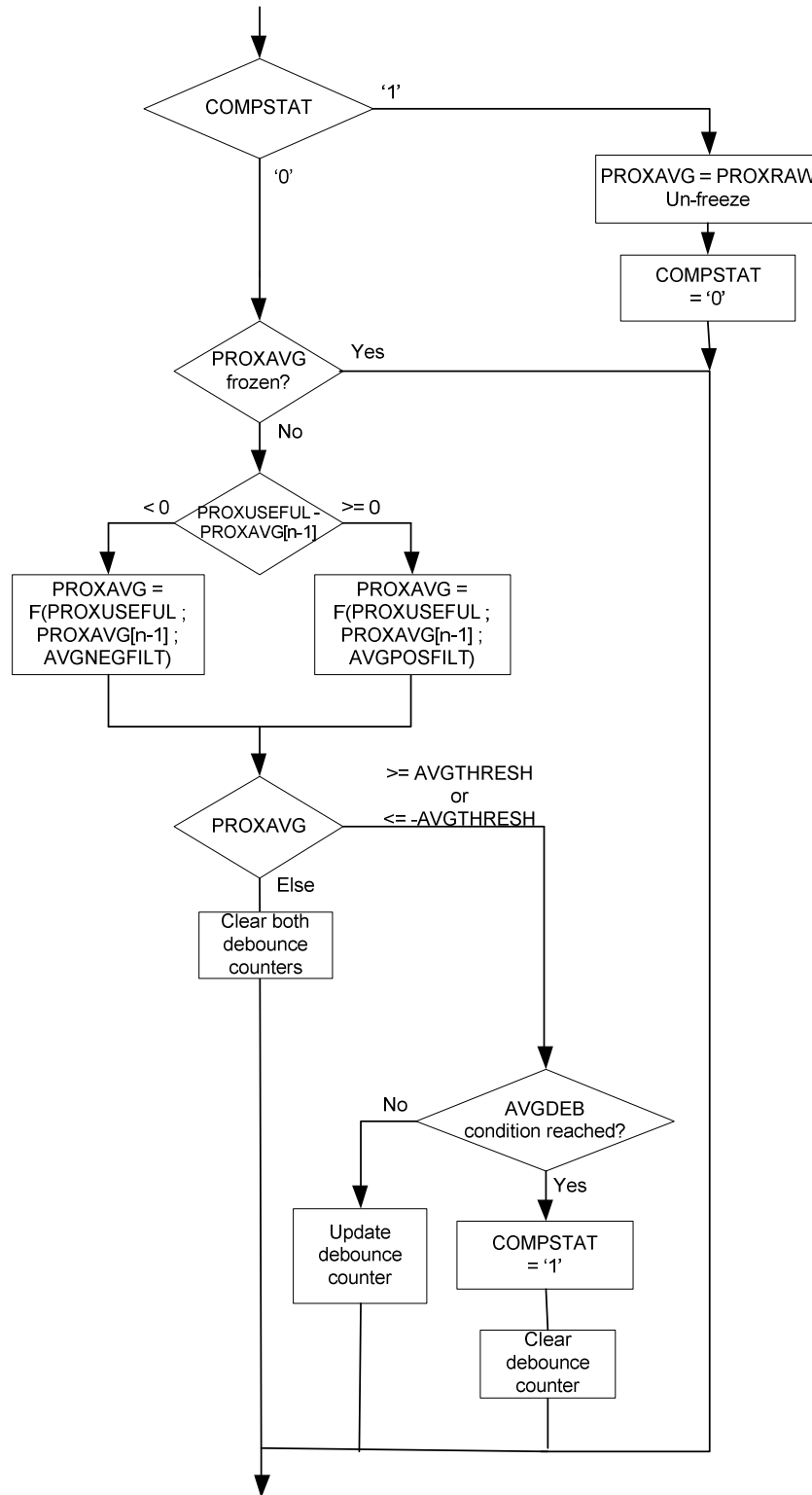

Figure 16: ProxAvg vs Proximity Event

Figure 17: ProxAvg Update

WIRELESS & SENSING
3.4.5 PROXDIF Update

PROXDIF update consists in the complementary operation i.e. subtracting PROXAVG to PROXUSEFUL to ignore slow capacitances variations (C_{Env}) and extract only the user related variations i.e. C_{User} .

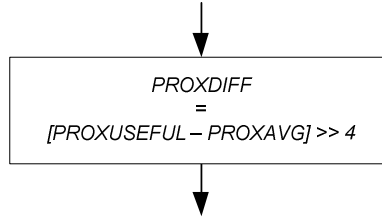

Figure 18: ProxDiff Update

Note that only the 12 upper bits of [PROXUSEFUL – PROXAVG] are kept for PROXDIF.

3.4.6 PROXSTAT Update

PROXSTAT update consists in taking PROXDIF information (C_{User}), comparing it with a user programmable threshold PROXTHRESH and finally updating PROXSTAT accordingly. When PROXSTAT=1, PROXAVG is frozen to prevent the user proximity signal averaging and hence absorbed into C_{Env} .

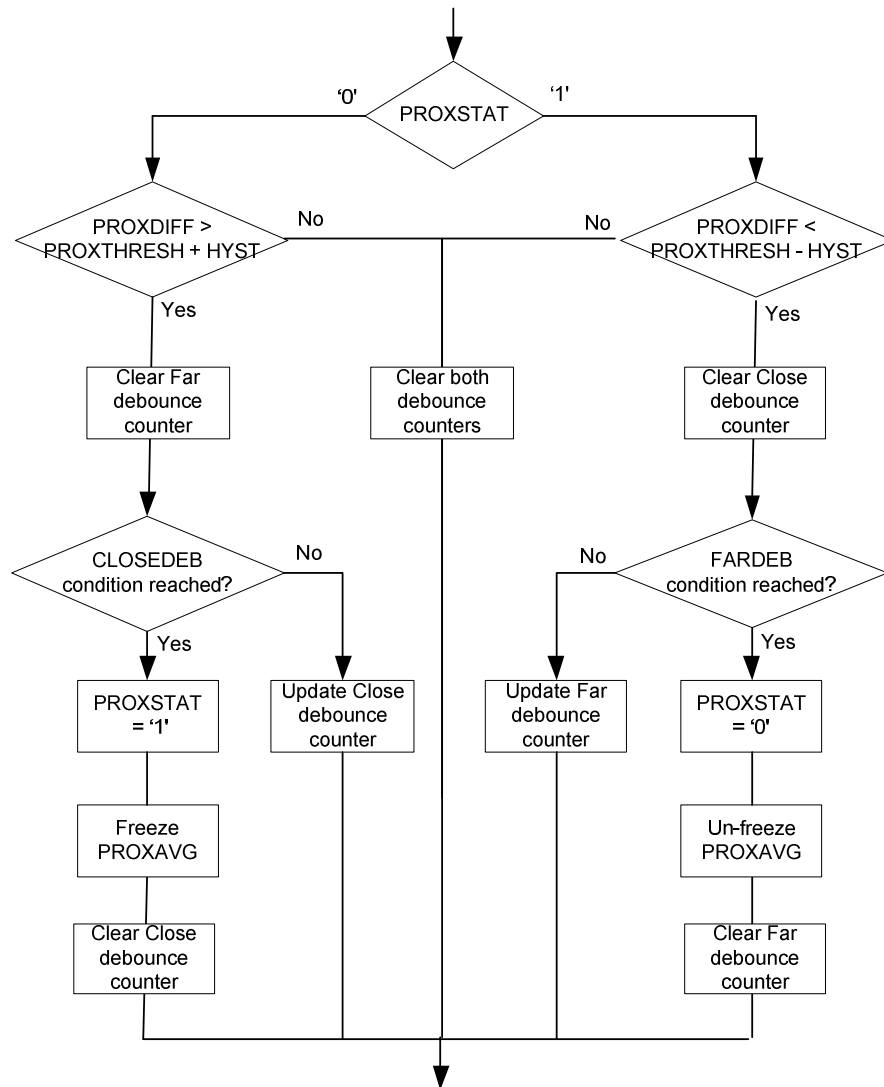

Figure 19: PROXSTAT Update

WIRELESS & SENSING
3.5 Host Operation

An interrupt can be triggered when the user is detected to be close (in range), detected to be far (out of range), or both (CLOSEIRQEN, FARIRQEN).

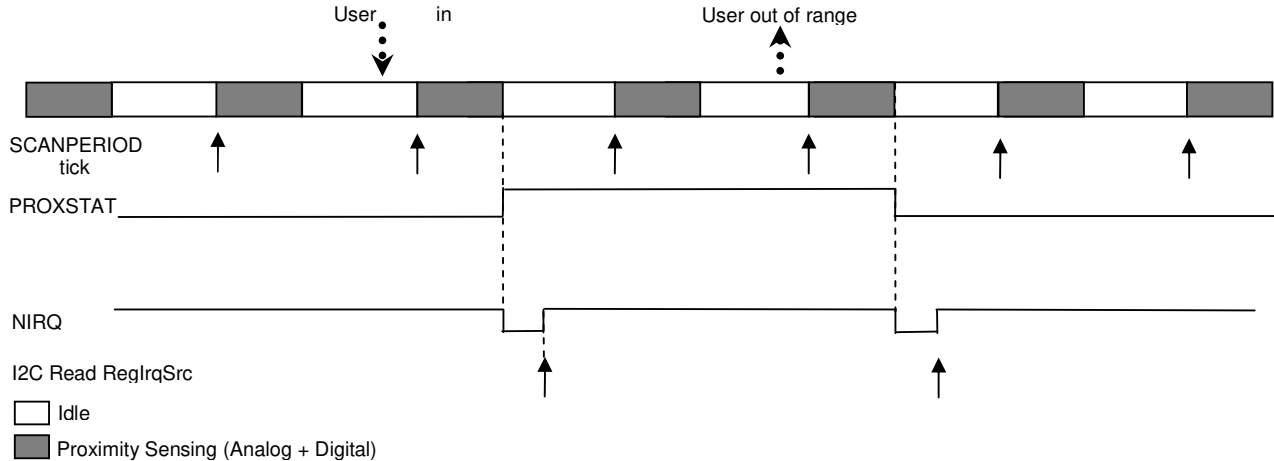

Figure 20: Proximity Sensing Host Operation (RegIrqMsk[6:3] = 1100)

An interrupt can also be triggered at the end of each proximity sensing operation, indicating to the host when the proximity sensing block is running (CONVDONEIRQEN). This may be used by the host to synchronize noisy system operations or to read sensor data (PROXUSEFUL, PROXAVG, PROXDIF) synchronously for monitoring purposes.

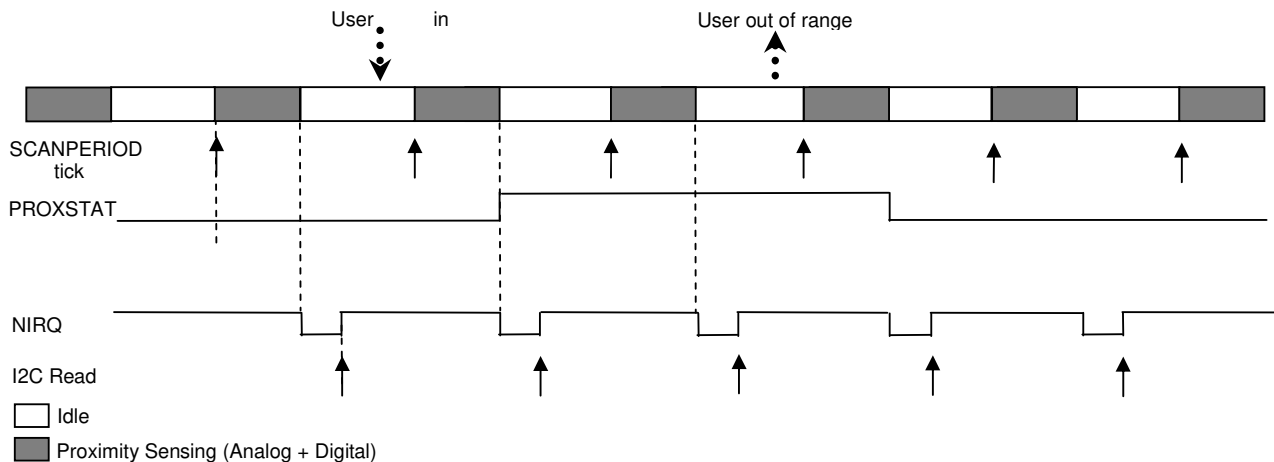

Figure 21: Proximity Sensing Host Operation (RegIrqMsk[6:3] = 0001)

In both cases above, an interrupt can also be triggered at the end of compensation (COMPDONEIRQEN).

3.6 Operational Modes

3.6.1 Active

Active mode has the shortest scan periods, typically 30ms. In this mode, all enabled sensors are scanned and information data is processed within this interval. The Active scan period is user configurable (SCANPERIOD) and can be extended up to 400ms.

3.6.2 Doze

In some applications, the reaction/sensing time needs to be fast when the user is present (proximity detected), but can be slow when not detection has been done for some time.

The Doze mode, when enabled (DOZEEN), allows the chip to automatically switch between a fast scan period (SCANPERIOD) during proximity detection and a slow scan period (DOZEPERIOD) when no proximity is being detected (up to 6.4s). This allows reaching low average power consumption values at the expense obviously of longer reaction times.

As soon as proximity is detected on any sensor, the chip will automatically switch to Active mode while when it has not detected an object for DOZEPERIOD, it will automatically switch to Doze mode.

3.6.3 Sleep

Sleep mode can be entered by disabling all sensors (SENSOREN=0000). It places the SX9500 in its lowest power mode, with sensor scanning completely disabled and idle period set to continuous. In this mode, only the I2C serial bus is active. Enabling any sensor will make the chip leave Sleep mode (for Doze if enabled, else Active mode)

3.6.4 TXEN Pin

The TXEN input enables proximity sensing when HIGH, likewise when the TXEN input is LOW, the SX9500 is in Sleep mode. Specifically, on the rising edge of TXEN the SX9500 will begin measuring the sensors normally at the programmed rate (SCANPERIOD, DOZEPERIOD) as long as TXEN remains HIGH. When TXEN goes LOW the current measurement sequence will complete and then measurement will cease until the next rising edge of TXEN.

This feature can be used to synchronize proximity sensing with noisy and/or RF activity for example.

WIRELESS & SENSING
4 I2C INTERFACE
4.1 Introduction

The I2C implemented on the SX9500 and used by the host to interact with it is compliant with:

- Standard (100kb/s) and fast mode (400kb/s)
- Slave mode
- 7-bit address (default is 0x28 assuming A1=A0=0)

The SX9500 has two I/O pins (A0 and A1) that provides four possible, user selectable I2C addresses:

A1	A0	Address
0	0	0x28
0	1	0x29
1	0	0x2A
1	1	0x2B

Table 8: I2C Sub-Address Selection

The host can use the I2C to read and write data at any time, and these changes are effective immediately. Therefore the user should ideally disable the sensor before changing settings, or discard the results while changing.

4.2 I2C Write

The format of the I2C write is given in Figure 12. After the start condition [S], the slave address (SA) is sent, followed by an eighth bit ('0') indicating a Write. The SX9500 then Acknowledges [A] that it is being addressed, and the Master sends an 8 bit Data Byte consisting of the SX9500 Register Address (RA). The Slave Acknowledges [A] and the master sends the appropriate 8 bit Data Byte (WD0). Again the Slave Acknowledges [A]. In case the master needs to write more data, a succeeding 8 bit Data Byte will follow (WD1), acknowledged by the slave [A]. This sequence will be repeated until the master terminates the transfer with the Stop condition [P].

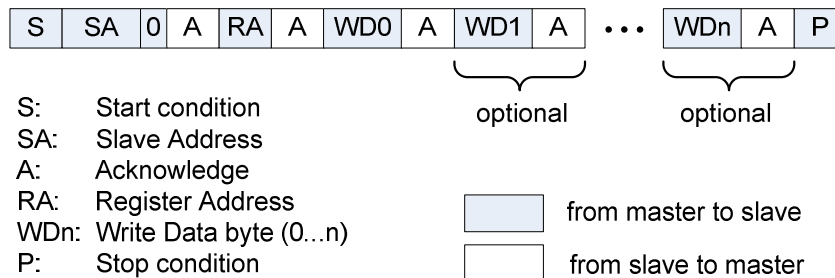

Figure 22: I2C Write

The register address is incremented automatically when successive register data (WD1...WDn) is supplied by the master.

4.3 I2C Read

The format of the I2C read is given in Figure 13. After the start condition [S], the slave address (SA) is sent, followed by an eighth bit ('0') indicating a Write. The SX9500 then Acknowledges [A] that it is being addressed, and the Master responds with an 8-bit Data consisting of the Register Address (RA). The Slave Acknowledges [A] and the master sends the Repeated Start Condition [Sr]. Once again, the slave address (SA) is sent, followed by an eighth bit ('1') indicating a Read. The SX9500 responds with an Acknowledge [A] and the read

WIRELESS & SENSING

Data byte (RD0). If the master needs to read more data it will acknowledge [A] and the SX9500 will send the next read byte (RD1). This sequence can be repeated until the master terminates with a NACK [N] followed by a stop [P].

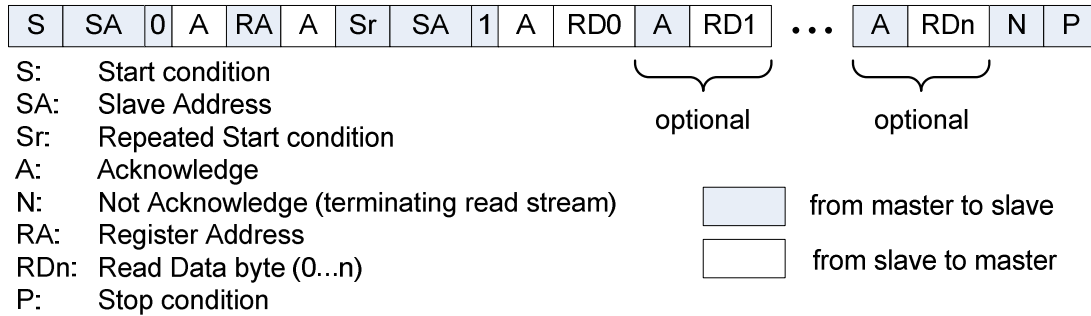

Figure 23: I2C Read

The register address is incremented automatically when successive register data (RD1...RDn) is retrieved by the master.

5 RESET
5.1 Power-up

During a power-up condition, the NIRQ output is HIGH until V_{DD} has met the minimum input voltage requirements and a T_{POR} time has expired upon which, NIRQ asserts to a LOW condition indicating the SX9500 is initialized. The host must perform an I2C read of RegIrqSrc to clear this NIRQ status. The SX9500 is then ready for normal I2C communication and is operational.

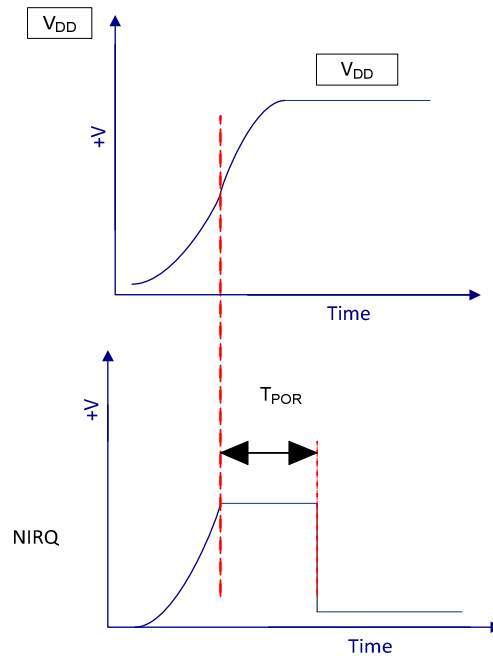

Figure 24: Power-up vs. NIRQ

5.2 NRST Pin

When the host asserts NRST LOW (for min. $T_{RESETPW}$) and then HIGH, the SX9500 will reset its internal registers and will become active after T_{POR} . When not used, this pin must be pulled high to SV_{DD} .

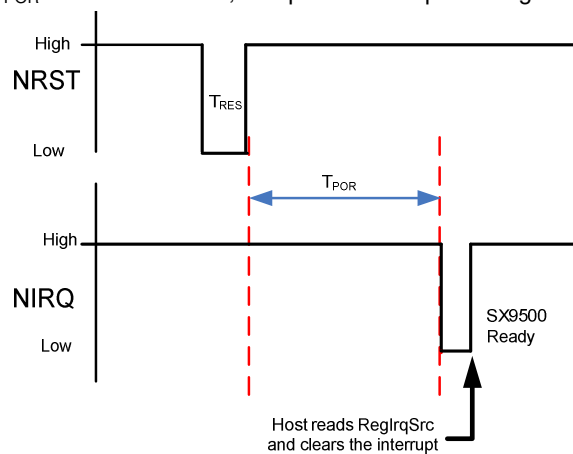

Figure 25: Hardware Reset

WIRELESS & SENSING**5.3 Software Reset**

The host can also perform a reset anytime by writing 0xDE into RegReset. The NIRQ output will be asserted LOW and the Host is required to perform an I2C read to clear this NIRQ status.

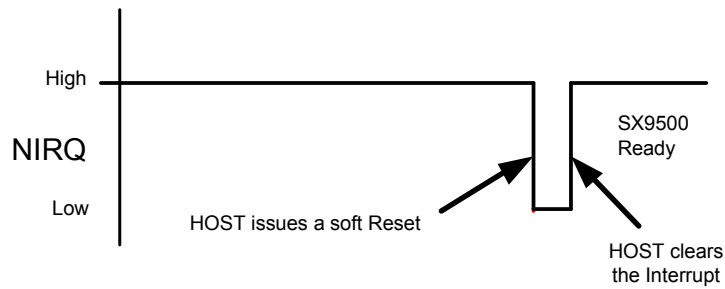

Figure 26: Software Reset

6 INTERRUPT

Except RESETIRQ, all interrupt sources are disabled by default upon power-up and resets, and thus must be enabled by the host. Any or all of the following interrupts can be enabled by writing a “1” into the appropriate locations within the RegIrqMsk register:

- Close (proximity detected)
- Far (proximity un-detected)
- Compensation completed
- Conversion completed

The interrupt status can be read from RegIrqSrc for each of these interrupt sources.

6.1 Power-up

During initial power-up, the NIRQ output is HIGH. Once the SX9500 internal power-up sequence has completed, NIRQ is asserted LOW, signaling that the SX9500 is ready. The host must perform a read to RegIrqSrc to acknowledge and the SX9500 will clear the interrupt and release the NIRQ line.

6.2 Assertion and Clearing

The NIRQ can be asserted in either the Active or Doze mode during a scan period. The NIRQ will be automatically cleared after the host performs a read of RegIrqSrc (which content will be cleared as well).