



Chipsmall Limited consists of a professional team with an average of over 10 year of expertise in the distribution of electronic components. Based in Hongkong, we have already established firm and mutual-benefit business relationships with customers from,Europe,America and south Asia,supplying obsolete and hard-to-find components to meet their specific needs.

With the principle of “Quality Parts,Customers Priority,Honest Operation,and Considerate Service”,our business mainly focus on the distribution of electronic components. Line cards we deal with include Microchip,ALPS,ROHM,Xilinx,Pulse,ON,Everlight and Freescale. Main products comprise IC,Modules,Potentiometer,IC Socket,Relay,Connector.Our parts cover such applications as commercial,industrial, and automotives areas.

We are looking forward to setting up business relationship with you and hope to provide you with the best service and solution. Let us make a better world for our industry!



Contact us

Tel: +86-755-8981 8866 Fax: +86-755-8427 6832

Email & Skype: info@chipsmall.com Web: www.chipsmall.com

Address: A1208, Overseas Decoration Building, #122 Zhenhua RD., Futian, Shenzhen, China



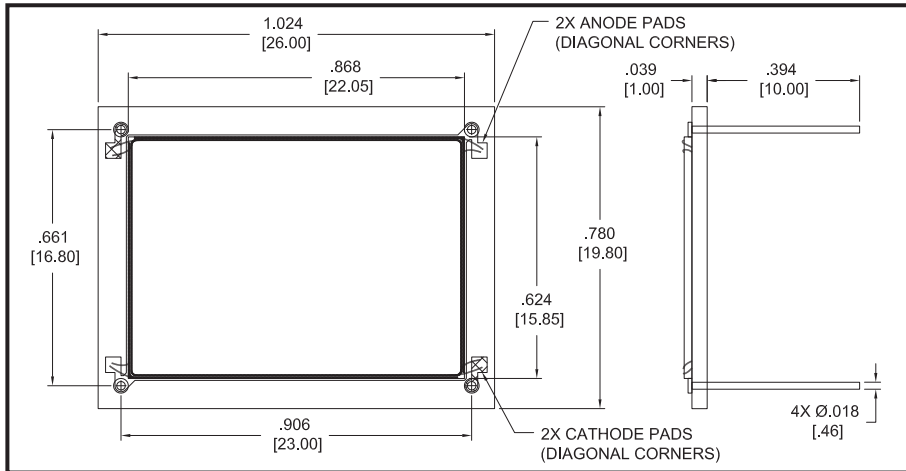

FEATURES

- Rectangular active area
- Excellent stability after EUV exposure
- Windowless package for responsivity to 1nm
- Ceramic package

Dimensions are in inch [metric] units.

ELECTRO-OPTICAL CHARACTERISTICS AT 25°C

PARAMETERS	TEST CONDITIONS	MIN	TYP	MAX	UNITS
Active Area	22.05 mm x 15.85 mm		331		mm ²
Responsivity, \mathcal{R}	See attached graph				
Shunt Resistance, R _{sh}	@ ± 10 mV	5			MOhms
Reverse Breakdown Voltage, V _R	I _R = 1 μA		25		Volts
Capacitance, C	V _R = 0V		40		nF
Response Time, tr	RL = 50Ω, V _R = 15V		15		nsec

THERMAL PARAMETERS

STORAGE AND OPERATING TEMPERATURE RANGE	
Ambient	-10° TO 40°C
Nitrogen or Vacuum	-20°C TO 80°C
Maximum Junction Temperature	70°C
Lead Soldering Temperature ¹	N/A

¹Soldering not recommended. Use with AXUV300CTS socket or equivalent.

