



Chipsmall Limited consists of a professional team with an average of over 10 year of expertise in the distribution of electronic components. Based in Hongkong, we have already established firm and mutual-benefit business relationships with customers from,Europe,America and south Asia,supplying obsolete and hard-to-find components to meet their specific needs.

With the principle of “Quality Parts,Customers Priority,Honest Operation,and Considerate Service”,our business mainly focus on the distribution of electronic components. Line cards we deal with include Microchip,ALPS,ROHM,Xilinx,Pulse,ON,Everlight and Freescale. Main products comprise IC,Modules,Potentiometer,IC Socket,Relay,Connector.Our parts cover such applications as commercial,industrial, and automotives areas.

We are looking forward to setting up business relationship with you and hope to provide you with the best service and solution. Let us make a better world for our industry!



Contact us

Tel: +86-755-8981 8866 Fax: +86-755-8427 6832

Email & Skype: info@chipsmall.com Web: www.chipsmall.com

Address: A1208, Overseas Decoration Building, #122 Zhenhua RD., Futian, Shenzhen, China



FEATURES

- 725ps max. D to output
- Extended 100E VEE range of -4.2V to -5.5V
- Differential outputs
- Split select architecture
- Fully compatible with industry standard 10KH, 100K ECL levels
- Internal 75KΩ input pulldown resistors
- Fully compatible with Motorola MC10E/100E171
- Available in 28-pin PLCC package

DESCRIPTION

The SY10/100E171 offer three 4:1 multiplexers with differential outputs, designed for use in new, high-performance ECL systems. The leading 4-bit multiplexer operation is organized pairwise, with each pair being a 2-bit multiplexer. Separate select (SEL1A, SEL1B) controls are provided within each pair. The SEL1A and SEL1B signals control the leading multiplexers, while the SEL2 signal controls the output multiplexer. The three select signals can be used to determine which of the four data inputs will be propagated to the corresponding outputs.

BLOCK DIAGRAM

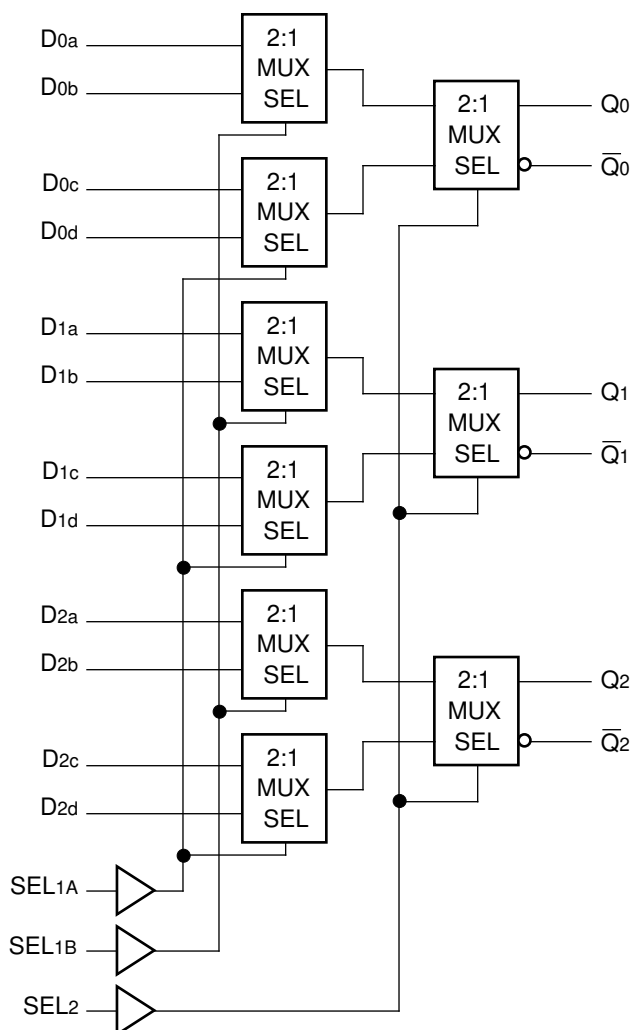

PIN NAMES

Pin	Function
D0x-D2x	Data Inputs
SEL1A, SEL1B	First-stage Select Inputs
SEL2	Second-stage Select Input
Q0-Q2	True Output
$\bar{Q}_0-\bar{Q}_2$	Inverted Output
VCC0	Vcc to Output

PACKAGE/ORDERING INFORMATION

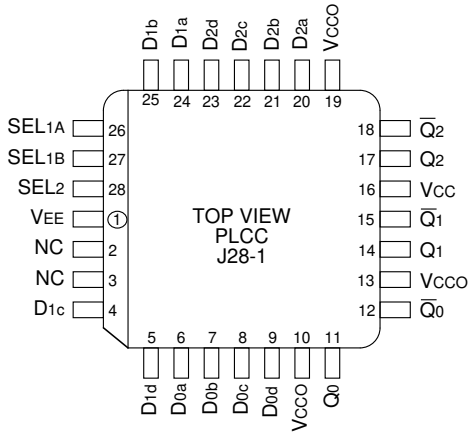

28-Pin PLCC (J28-1)

Ordering Information⁽¹⁾

Part Number	Package Type	Operating Range	Package Marking	Lead Finish
SY10E171JC	J28-1	Commercial	SY10E171JC	Sn-Pb
SY10E171JCTR ⁽²⁾	J28-1	Commercial	SY10E171JC	Sn-Pb
SY100E171JC	J28-1	Commercial	SY100E171JC	Sn-Pb
SY100E171JCTR ⁽²⁾	J28-1	Commercial	SY100E171JC	Sn-Pb
SY10E171JZ ⁽³⁾	J28-1	Commercial	SY10E171JZ with Pb-Free bar-line indicator	Matte-Sn
SY10E171JZTR ^(2, 3)	J28-1	Commercial	SY10E171JZ with Pb-Free bar-line indicator	Matte-Sn
SY100E171JZ ⁽³⁾	J28-1	Commercial	SY100E171JZ with Pb-Free bar-line indicator	Matte-Sn
SY100E171JZTR ^(2, 3)	J28-1	Commercial	SY100E171JZ with Pb-Free bar-line indicator	Matte-Sn

Notes:

1. Contact factory for die availability. Dice are guaranteed at T_A = 25°C, DC Electricals only.
2. Tape and Reel.
3. Pb-Free package is recommended for new designs.

TRUTH TABLE

Pin	State	Operation
SEL2	H	Output c/d data
SEL1A	H	Input d data
SEL1B	H	Input b data

DC ELECTRICAL CHARACTERISTICS

$V_{EE} = V_{EE} (\text{Min.})$ to $V_{EE} (\text{Max.})$; $V_{CC} = V_{CCO} = \text{GND}$

Symbol	Parameter	$T_A = 0^\circ\text{C}$			$T_A = +25^\circ\text{C}$			$T_A = +85^\circ\text{C}$			Unit	Condition	
		Min.	Typ.	Max.	Min.	Typ.	Max.	Min.	Typ.	Max.			
I _{IH}	Input HIGH Current	—	—	150	—	—	150	—	—	150	μA	—	
I _{EE}	Power Supply Current										mA	—	
		10E	—	56	67	—	56	67	—	56			67
		100E	—	56	67	—	56	67	—	65			77

AC ELECTRICAL CHARACTERISTICS

$V_{EE} = V_{EE} (\text{Min.})$ to $V_{EE} (\text{Max.})$; $V_{CC} = V_{CCO} = \text{GND}$

Symbol	Parameter	$T_A = 0^\circ\text{C}$			$T_A = +25^\circ\text{C}$			$T_A = +85^\circ\text{C}$			Unit	Condition	
		Min.	Typ.	Max.	Min.	Typ.	Max.	Min.	Typ.	Max.			
t _{PD}	Propagation Delay to Output D	275	480	650	275	480	650	275	480	650	ps	—	
		SEL1	450	650	850	450	650	850	450	650			850
		SEL2	350	550	700	350	550	700	350	550			700
t _{skew}	Within-Device Skew D _{nm} , D _{nm} to Q _n D _a , D _b , D _c , D _d to Q	—	60	—	—	60	—	—	60	—	ps	1	
		—	40	—	—	40	—	—	40	—			
t _r t _f	Rise/Fall Time 20% to 80%	300	475	650	300	475	650	300	475	650	ps	—	

Note:

1. Within-device skew is defined as identical transitions on similar paths through a device; n = 0, 1, 2 m = a, b, c, d.

28-PIN PLCC (J28-1)

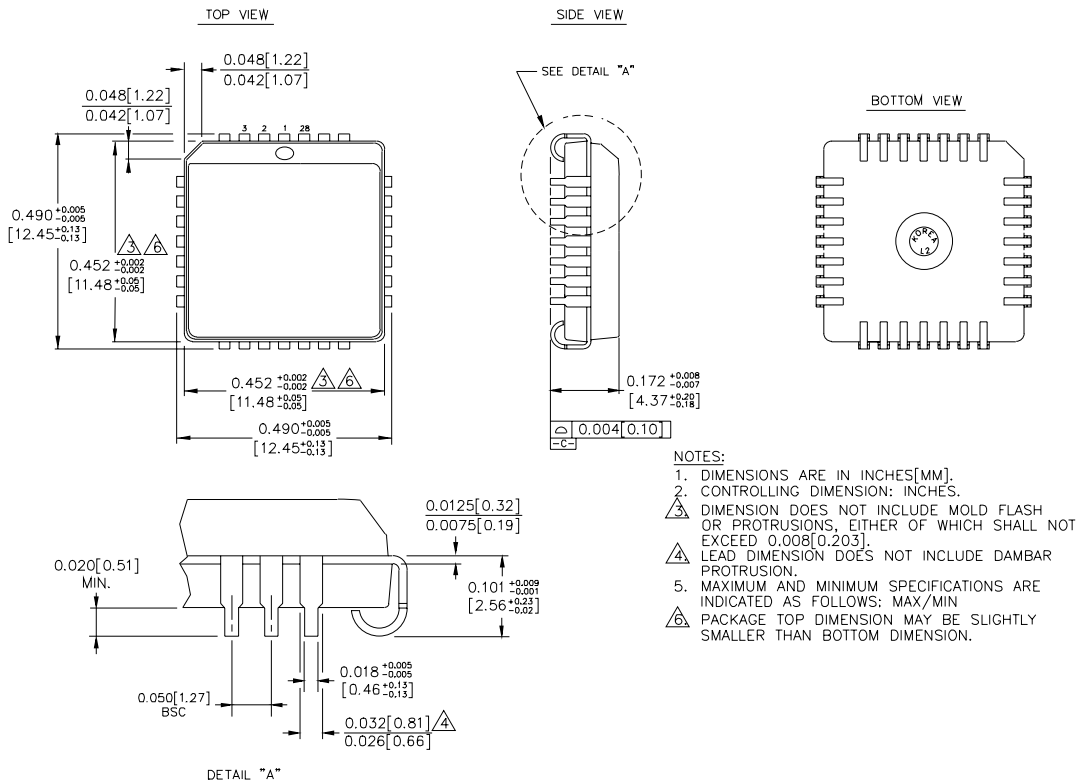

Rev. 03

MICREL, INC. 2180 FORTUNE DRIVE SAN JOSE, CA 95131 USA

TEL + 1 (408) 944-0800 FAX + 1 (408) 474-1000 WEB <http://www.micrel.com>

The information furnished by Micrel in this data sheet is believed to be accurate and reliable. However, no responsibility is assumed by Micrel for its use. Micrel reserves the right to change circuitry and specifications at any time without notification to the customer.

Micrel Products are not designed or authorized for use as components in life support appliances, devices or systems where malfunction of a product can reasonably be expected to result in personal injury. Life support devices or systems are devices or systems that (a) are intended for surgical implant into the body or (b) support or sustain life, and whose failure to perform can be reasonably expected to result in a significant injury to the user. A Purchaser's use or sale of Micrel Products for use in life support appliances, devices or systems is at Purchaser's own risk and Purchaser agrees to fully indemnify Micrel for any damages resulting from such use or sale.

© 2006 Micrel, Incorporated.