



Chipsmall Limited consists of a professional team with an average of over 10 year of expertise in the distribution of electronic components. Based in Hongkong, we have already established firm and mutual-benefit business relationships with customers from,Europe,America and south Asia,supplying obsolete and hard-to-find components to meet their specific needs.

With the principle of “Quality Parts,Customers Priority,Honest Operation,and Considerate Service”,our business mainly focus on the distribution of electronic components. Line cards we deal with include Microchip,ALPS,ROHM,Xilinx,Pulse,ON,Everlight and Freescale. Main products comprise IC,Modules,Potentiometer,IC Socket,Relay,Connector.Our parts cover such applications as commercial,industrial, and automotives areas.

We are looking forward to setting up business relationship with you and hope to provide you with the best service and solution. Let us make a better world for our industry!



Contact us

Tel: +86-755-8981 8866 Fax: +86-755-8427 6832

Email & Skype: info@chipsmall.com Web: www.chipsmall.com

Address: A1208, Overseas Decoration Building, #122 Zhenhua RD., Futian, Shenzhen, China





**DIFFERENTIAL DATA AND
CLOCK D FLIP-FLOP**

**SY10EL52
SY100EL52**

FEATURES

- 365ps propagation delay
- 2.0GHz toggle frequency
- Internal 75kΩ input pull-down resistors
- Available in 8-pin SOIC package

DESCRIPTION

The SY10/100EL52 are differential data, differential clock D flip-flops. These devices are functionally equivalent to the E452 devices, with higher performance capabilities. With propagation delays and output transition times significantly faster than the E452, the EL52 is ideally suited for those applications which require the ultimate in AC performance.

Data enters the master portion of the flip-flop when the clock is LOW and is transferred to the slave, and thus the outputs, upon a positive transition of the clock. The differential clock inputs also allow the EL52 to be used as a negative edge triggered device.

The EL52 employs input clamping circuitry so that, under open input conditions (pulled down to VEE), the outputs of the device will remain stable.

PIN NAMES

Pin	Function
D	Data Input
CLK	Clock Input
Q	Data Output

TRUTH TABLE⁽¹⁾

D	CLK	Q
L	Z	L
H	Z	H

NOTE:

1. Z = LOW-to-HIGH transition.

PACKAGE/ORDERING INFORMATION

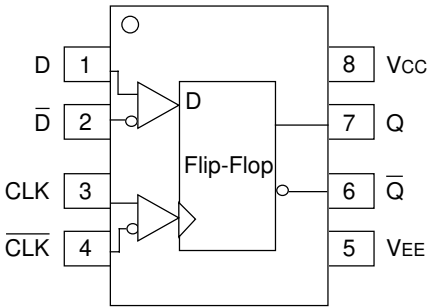

8-Pin SOIC (Z8-1)

Ordering Information⁽¹⁾

Part Number	Package Type	Operating Range	Package Marking	Lead Finish
SY10EL52ZC	Z8-1	Commercial	HEL52	Sn-Pb
SY10EL52ZCTR ⁽²⁾	Z8-1	Commercial	HEL52	Sn-Pb
SY100EL52ZC	Z8-1	Commercial	XEL52	Sn-Pb
SY100EL52ZCTR ⁽²⁾	Z8-1	Commercial	XEL52	Sn-Pb
SY10EL52ZI	Z8-1	Industrial	HEL52	Sn-Pb
SY10EL52ZITR ⁽²⁾	Z8-1	Industrial	HEL52	Sn-Pb
SY100EL52ZI	Z8-1	Industrial	XEL52	Sn-Pb
SY100EL52ZITR ⁽²⁾	Z8-1	Industrial	XEL52	Sn-Pb
SY10EL52ZG ⁽³⁾	Z8-1	Industrial	HEL52 with Pb-Free bar-line indicator	Pb-Free NiPdAu
SY10EL52ZGTR ^(2, 3)	Z8-1	Industrial	HEL52 with Pb-Free bar-line indicator	Pb-Free NiPdAu
SY100EL52ZG ⁽³⁾	Z8-1	Industrial	XEL52 with Pb-Free bar-line indicator	Pb-Free NiPdAu
SY100EL52ZGTR ^(2, 3)	Z8-1	Industrial	XEL52 with Pb-Free bar-line indicator	Pb-Free NiPdAu

Notes:

1. Contact factory for die availability. Dice are guaranteed at T_A = 25°C, DC Electricals only.
2. Tape and Reel.
3. Pb-Free package is recommended for new designs.

DC ELECTRICAL CHARACTERISTICS

VEE = VEE (Min.) to VEE (Max.); VCC = GND

Symbol	Parameter	TA = -40°C			TA = 0°C			TA = +25°C			TA = +85°C			Unit	
		Min.	Typ.	Max.	Min.	Typ.	Max.	Min.	Typ.	Max.	Min.	Typ.	Max.		
IEE	Power Supply Current	10EL	—	21	25	17	21	25	17	21	25	17	21	25	mA
		100EL	—	21	25	17	21	25	17	21	25	19	24	29	
VEE	Power Supply Voltage	10EL	-4.75	-5.2	-5.5	-4.75	-5.2	-5.5	-4.75	-5.2	-5.5	-4.75	-5.2	-5.5	V
		100EL	-4.20	-4.5	-5.5	-4.20	-4.5	-5.5	-4.20	-4.5	-5.5	-4.20	-4.5	-5.5	
I _{IH}	Input HIGH Current	—	—	150	—	—	150	—	—	150	—	—	150	μA	

AC ELECTRICAL CHARACTERISTICS

VEE = VEE (Min.) to VEE (Max.); VCC = GND

Symbol	Parameter	TA = -40°C			TA = 0°C			TA = +25°C			TA = +85°C			Unit
		Min.	Typ.	Max.	Min.	Typ.	Max.	Min.	Typ.	Max.	Min.	Typ.	Max.	
f _{MAX}	Maximum Toggle Frequency	1.8	2.5	—	2.2	2.8	—	2.2	2.8	—	2.2	2.8	—	GHz
t _{PD}	Propagation Delay to Output CLK	235	335	515	275	365	465	275	365	465	320	410	510	ps
t _S	Set-up Time	125	0	—	125	0	—	125	0	—	125	0	—	ps
t _H	Hold Time	150	50	—	150	50	—	150	50	—	150	50	—	ps
t _{PW}	Minimum Pulse Width	400	—	—	400	—	—	400	—	—	400	—	—	ps
V _{PP}	Minimum Input Swing ⁽¹⁾	150	—	—	150	—	—	150	—	—	150	—	—	mV
V _{CMR}	Common Mode Range ⁽²⁾													V
	D (10EL)	-0.4	—	-1.6	-0.4	—	-1.6	-0.4	—	-1.6	-0.4	—	-1.6	
	D (100EL)	-0.4	—	-1.2	-0.4	—	-1.2	-0.4	—	-1.2	-0.4	—	-1.2	
	CLK (10EL)	-0.6	—	(3)	-0.6	—	(3)	-0.6	—	(3)	-0.6	—	(3)	
	CLK (100EL)	-0.8	—	(3)	-0.8	—	(3)	-0.8	—	(3)	-0.8	—	(3)	
t _r t _f	Output Rise/Fall Times Q (20% to 80%)	100	225	350	100	225	350	100	225	350	100	225	350	ps

NOTES:

1. Minimum input swing for which AC parameters are guaranteed.
2. The CMR range is referenced to the most positive side of the differential input signal. Normal operation is obtained if the HIGH level falls within the specified range and the peak-to-peak voltage lies between V_{PP} min. and 1V.
3. The lower end of the CMR range is dependent on V_{EE} and is equal to V_{EE} + 3.0V.

8-PIN SOIC .150" WIDE (Z8-1)

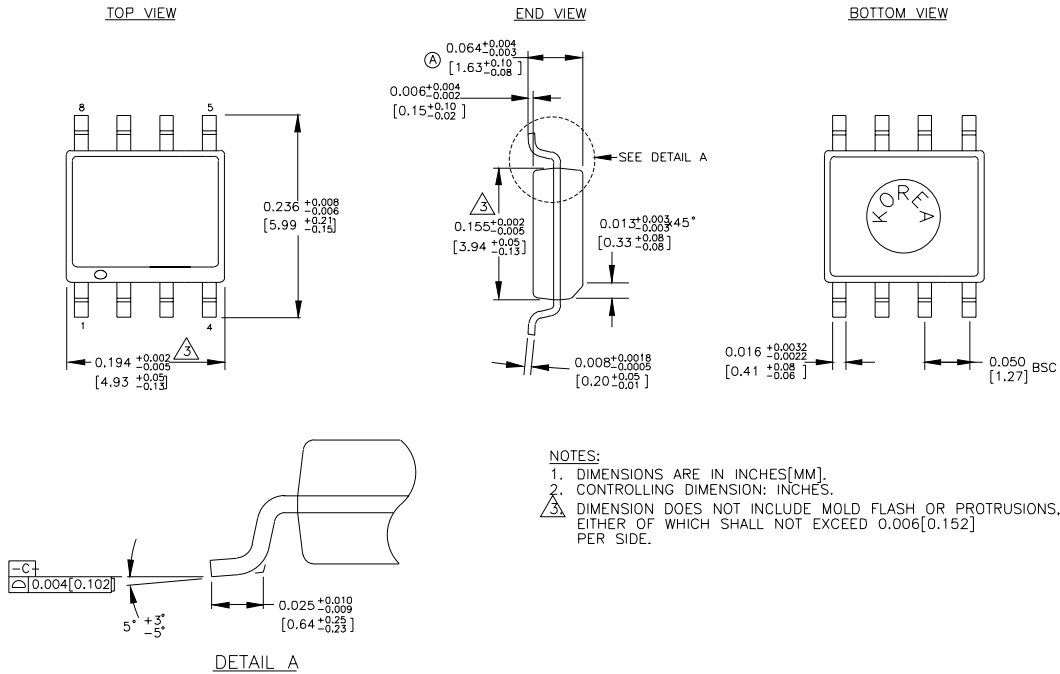

Rev. 03

MICREL, INC. 2180 FORTUNE DRIVE SAN JOSE, CA 95131 USA

TEL + 1 (408) 944-0800 FAX + 1 (408) 474-1000 WEB <http://www.micrel.com>

The information furnished by Micrel in this datasheet is believed to be accurate and reliable. However, no responsibility is assumed by Micrel for its use. Micrel reserves the right to change circuitry and specifications at any time without notification to the customer.

Micrel Products are not designed or authorized for use as components in life support appliances, devices or systems where malfunction of a product can reasonably be expected to result in personal injury. Life support devices or systems are devices or systems that (a) are intended for surgical implant into the body or (b) support or sustain life, and whose failure to perform can be reasonably expected to result in a significant injury to the user. A Purchaser's use or sale of Micrel Products for use in life support appliances, devices or systems is at Purchaser's own risk and Purchaser agrees to fully indemnify Micrel for any damages resulting from such use or sale.

© 2005 Micrel, Incorporated.