



Chipsmall Limited consists of a professional team with an average of over 10 year of expertise in the distribution of electronic components. Based in Hongkong, we have already established firm and mutual-benefit business relationships with customers from,Europe,America and south Asia,supplying obsolete and hard-to-find components to meet their specific needs.

With the principle of “Quality Parts,Customers Priority,Honest Operation,and Considerate Service”,our business mainly focus on the distribution of electronic components. Line cards we deal with include Microchip,ALPS,ROHM,Xilinx,Pulse,ON,Everlight and Freescale. Main products comprise IC,Modules,Potentiometer,IC Socket,Relay,Connector.Our parts cover such applications as commercial,industrial, and automotives areas.

We are looking forward to setting up business relationship with you and hope to provide you with the best service and solution. Let us make a better world for our industry!



## Contact us

Tel: +86-755-8981 8866 Fax: +86-755-8427 6832

Email & Skype: info@chipsmall.com Web: www.chipsmall.com

Address: A1208, Overseas Decoration Building, #122 Zhenhua RD., Futian, Shenzhen, China



## FEATURES

- 2.5V and 3.3V power supply options
- Guaranteed AC parameters over temperature:
  - $f_{MAX} = 3\text{GHz}$
  - < 25ps output-to-output skew
  - < 250ps  $t_r / t_f$
  - < 400ps propagation delay
- Wide temperature range:  $-40^{\circ}\text{C}$  to  $+85^{\circ}\text{C}$
- Differential design
- $V_{BB}$  output for single-ended input applications
- Fully compatible with industry standard 100K I/O levels
- Available in 32-pin TQFP package



Precision Edge®

## DESCRIPTION

The SY100EP111U is a high-speed, low skew 1-to-10 differential fanout buffer designed for clock distribution in new, high-performance systems. The internal 2:1 mux allows the input to select between two differential clock sources.

The device is specifically designed for low skew. The interconnect scheme and metal layout are carefully optimized for minimal gate-to-gate skew within the device. Wafer characterization and process control ensure consistent distribution of propagation delay from lot to lot.

The  $V_{BB}$  output is intended for use as a reference voltage for single-ended reception of ECL signals to that device only. When using  $V_{BB}$  for this purpose, it is recommended that  $V_{BB}$  is decoupled to  $V_{CC}$  via a  $0.01\mu\text{F}$  capacitor.

## BLOCK DIAGRAM

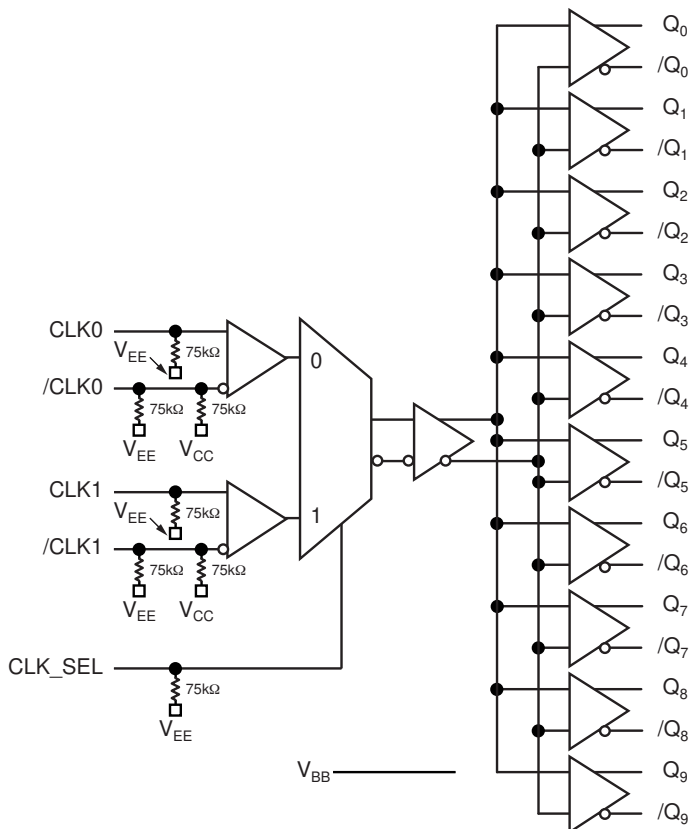

**PACKAGE/ORDERING INFORMATION**

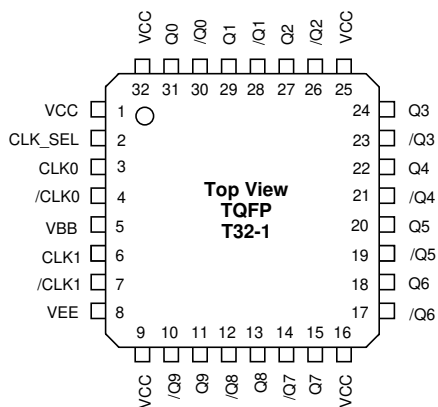

**32-Pin TQFP (T32-1)**

**Ordering Information<sup>(1)</sup>**

Part Number	Package Type	Operating Range	Package Marking	Lead Finish
SY100EP111UTI	T32-1	Industrial	100EP111UTI	Sn-Pb
SY100EP111UTITR <sup>(2)</sup>	T32-1	Industrial	100EP111UTI	Sn-Pb
SY100EP111UTG <sup>(3)</sup>	T32-1	Industrial	100EP111UTG with Pb-Free bar-line indicator	Pb-Free NiPdAu
SY100EP111UTGTR <sup>(2, 3)</sup>	T32-1	Industrial	100EP111UTG with Pb-Free bar-line indicator	Pb-Free NiPdAu
SY100EP111UTGTX <sup>(2, 4)</sup>	T32-1	Industrial	100EP111UTG with Pb-Free bar-line indicator	Pb-Free NiPdAu

**Notes:**

1. Contact factory for die availability. Dice are guaranteed at T<sub>A</sub> = 25°C, DC Electricals only.
2. Tape and Reel.
3. Pb-Free package is recommended for new designs.
4. EIA specification orientation.

**PIN NAMES**

**FUNCTION TABLE**

Pin	Function
CLK0, /CLK0	LVPECL, LVECL, HSTL Clock Inputs: CLK0 input includes a 75kΩ pull-down. Default is low if left floating. /CLK0 includes an internal 75kΩ pull-up and pull-down. Default state is V <sub>CC</sub> /2.
CLK1, /CLK1	LVPECL, LVECL, HSTL Clock Inputs: CLK input includes a 75kΩ pull-down. Default is low if left floating. /CLK includes an internal 75kΩ pull-up and pull-down. Default state is V <sub>CC</sub> /2.
Q0 to Q9	LVPECL/LVECL Outputs.
/Q0 to /Q9	Complementary LVPECL/LVECL Outputs.
CLK_SEL	LVPECL/LVECL Clock Select Input: Internal 75kΩ resistor connected to V <sub>EE</sub> . When left floating, the default condition is LOW.
V <sub>BB</sub>	Reference Voltage: AC coupled or single-ended input applications.
V <sub>CC</sub>	Positive Power Supply: Bypass with 0.1μF//0.01μF low ESR capacitors.
V <sub>EE</sub>	Negative Power Supply: LVPECL operation, connect to GND.

CLK_SEL	Active Input
0	CLK0, /CLK0
1	CLK1, /CLK1

**ABSOLUTE MAXIMUM RATINGS<sup>(1)</sup>**

Symbol	Rating	Value	Unit
$V_{CC} - V_{EE}$	Power Supply Voltage	6.0	V
$V_{IN}$	Input Voltage ( $V_{CC} = 0V$ , $V_{IN}$ not more negative than $V_{EE}$ ) Input Voltage ( $V_{EE} = 0V$ , $V_{IN}$ not more positive than $V_{CC}$ )	-6.0 to 0 +6.0 to 0	V
$I_{OUT}$	Output Current -Continuous -Surge	50 100	mA
$I_{BB}$	$V_{BB}$ Sink/Source Current <sup>(2)</sup>	±0.5	mA
$T_{LEAD}$	Lead Temperature (soldering, 20sec.)	+260	°C
$T_A$	Operating Temperature Range	-40 to +85	°C
$T_{store}$	Storage Temperature Range	-65 to +150	°C
$\theta_{JA}$	Package Thermal Resistance (Junction-to-Ambient) -Still-Air -500lfpm	50 42	°C/W
$\theta_{JC}$	Package Thermal Resistance (Junction-to-Case)	20	°C/W

**Note 1.** Permanent device damage may occur if absolute maximum ratings are exceeded. This is a stress rating only and functional operation is not implied at conditions other than those detailed in the operational sections of this data sheet. Exposure to absolute maximum rating conditions for extended periods may affect device reliability.

**Note 2.** Due to the limited drive capability, use for inputs of same package only.

**DC ELECTRICAL CHARACTERISTICS<sup>(1)</sup>**

Symbol	Parameter	$T_A = -40^\circ C$			$T_A = +25^\circ C$			$T_A = +85^\circ C$			Unit	Condition
		Min.	Typ.	Max.	Min.	Typ.	Max.	Min.	Typ.	Max.		
$V_{CC}$	Power Supply Voltage (LVPECL) (LVECL)	2.375	—	3.8	2.375	—	3.8	2.375	—	3.8	V	
		-3.8	—	-2.375	-3.8	—	-2.375	-3.8	—	-2.375	V	
$I_{EE}$	Power Supply Current	—	55	120	—	70	120	—	85	120	mA	
$I_{IH}$	Input HIGH Current	—	—	150	—	—	150	—	—	150	µA	$V_{IN} = V_{IH}$
$I_{IL}$	Input LOW Current CLK0, CLK1 /CLK0, /CLK1	0.5	—	—	0.5	—	—	0.5	—	—	µA	$V_{IN} = V_{IL}$ $V_{IN} = V_{IL}$
		-150	—	—	-150	—	—	-150	—	—	µA	
$C_{IN}$	Input Capacitance	—	—	—	—	2	—	—	—	—	pF	

**Note 1.** 100KEP circuits are designed to meet the DC specifications shown in the above table after thermal equilibrium has been established. The circuit is in a test socket or mounted on a printed circuit board and traverse airflow greater than 500lfpm is maintained.

**LVPECL DC ELECTRICAL CHARACTERISTICS<sup>(1)</sup>**

$V_{CC} = 3.3V \pm 10\%$ ;  $V_{EE} = 0V$

Symbol	Parameter	$T_A = -40^\circ C$			$T_A = +25^\circ C$			$T_A = +85^\circ C$			Unit	Condition
		Min.	Typ.	Max.	Min.	Typ.	Max.	Min.	Typ.	Max.		
$V_{IH}$	Input HIGH Voltage (Single-Ended)	2135	—	2420	2135	—	2420	2135	—	2420	mV	
$V_{IL}$	Input LOW Voltage (Single-Ended)	1355	—	1675	1355	—	1675	1355	—	1675	mV	
$V_{OL}$	Output LOW Voltage	1355	1480	1605	1355	1480	1605	1355	1480	1605	mV	$50\Omega$ to $V_{CC}-2V$
$V_{OH}$	Output HIGH Voltage	2155	2280	2405	2155	2280	2405	2155	2280	2405	mV	$50\Omega$ to $V_{CC}-2V$
$V_{BB}$	Reference Voltage <sup>(2)</sup>	1775	1875	1975	1775	1875	1975	1775	1875	1975	mV	
$V_{IHCMR}$	Input HIGH Voltage Common Mode Range <sup>(3)</sup>	1.2	—	$V_{CC}$	1.2	—	$V_{CC}$	1.2	—	$V_{CC}$	V	

- Note 1.** 100KEP circuits are designed to meet the DC specifications shown in the above table after thermal equilibrium has been established. The circuit is in a test socket or mounted on a printed circuit board and traverse airflow greater than 500lfpm is maintained. Input and output varies 1:1 with  $V_{CC}$ .
- Note 2.** Single-ended input operation is limited  $V_{CC} \geq 3.0V$  in LVPECL mode.  $V_{BB}$  reference varies 1:1 with  $V_{CC}$ .
- Note 3.**  $V_{IHCMR}$  (Min) varies 1:1 with  $V_{EE}$ ,  $V_{IHCMR}$  (Max) varies 1:1 with  $V_{CC}$ . The  $V_{IHCMR}$  range is referenced to the most positive side of the differential input signal.

**LVPECL DC ELECTRICAL CHARACTERISTICS<sup>(1)</sup>**

$V_{CC} = 2.5V \pm 5\%$ ,  $V_{EE} = 0V$

Symbol	Parameter	$T_A = -40^\circ C$			$T_A = +25^\circ C$			$T_A = +85^\circ C$			Unit	Condition
		Min.	Typ.	Max.	Min.	Typ.	Max.	Min.	Typ.	Max.		
$V_{IH}$	Input HIGH Voltage (Single-ended)	1335	—	1620	1335	—	1620	1335	—	1620	mV	
$V_{IL}$	Input LOW Voltage (Single-ended)	555	—	875	555	—	875	555	—	875	mV	
$V_{OL}$	Output LOW Voltage	555	680	805	555	680	805	555	680	805	mV	$50\Omega$ to $V_{CC}-2V$
$V_{OH}$	Output HIGH Voltage	1355	1480	1605	1355	1480	1605	1355	1480	1605	mV	$50\Omega$ to $V_{CC}-2V$
$V_{IHCMR}$	Input HIGH Voltage Common Mode Range <sup>(2)</sup>	1.2	—	$V_{CC}$	1.2	—	$V_{CC}$	1.2	—	$V_{CC}$	V	

- Note 1.** 100KEP circuits are designed to meet the DC specifications shown in the above table after thermal equilibrium has been established. The circuit is in a test socket or mounted on a printed circuit board and traverse airflow greater than 500lfpm is maintained. Input and output varies 1:1 with  $V_{CC}$ .
- Note 2.**  $V_{IHCMR}$  (Min) varies 1:1 with  $V_{EE}$ ,  $V_{IHCMR}$  (Max) varies 1:1 with  $V_{CC}$ . The  $V_{IHCMR}$  range is referenced to the most positive side of the differential input signal.

**LVECL DC ELECTRICAL CHARACTERISTICS<sup>(1)</sup>**

$V_{EE} = -2.375V$  to  $-3.8V$ ;  $V_{CC} = 0V$

Symbol	Parameter	$T_A = -40^{\circ}C$			$T_A = +25^{\circ}C$			$T_A = +85^{\circ}C$			Unit	Condition
		Min.	Typ.	Max.	Min.	Typ.	Max.	Min.	Typ.	Max.		
$V_{IL}$	Input LOW Voltage (Single-ended)	-1945	—	-1625	-1945	—	-1625	-1945	—	-1625	mV	
$V_{IH}$	Input HIGH Voltage (Single-ended)	-1165	—	-0880	-1165	—	-0880	-1165	—	-0880	mV	
$V_{OL}$	Output LOW Voltage	-1945	-1820	-1695	-1945	-1820	-1695	-1945	-1820	-1695	mV	$50\Omega$ to $V_{CC}-2V$
$V_{OH}$	Output HIGH Voltage	-1145	-1020	-0895	-1145	-1020	-0895	-1145	-1020	-0895	mV	$50\Omega$ to $V_{CC}-2V$
$V_{BB}$	Output Reference Voltage <sup>(2)</sup>	-1525	-1425	-1325	-1525	-1425	-1325	-1525	-1425	-1325	mV	
$V_{IHCMR}$	Input HIGH Voltage Common Mode Range <sup>(3)</sup>	$V_{EE} + 1.2$		0.0	$V_{EE} + 1.2$		0.0	$V_{EE} + 1.2$		0.0	V	

**Note 1.** 100KEP circuits are designed to meet the DC specifications shown in the above table after thermal equilibrium has been established. The circuit is in a test socket or mounted on a printed circuit board and traverse airflow greater than 500lfpm is maintained.

**Note 2.** Single-ended input operation is limited  $V_{EE} \leq -3.0V$  in LVECL mode.

**Note 3.**  $V_{IHCMR}$  (min) varies 1:1 with  $V_{EE}$ . The  $V_{IHCMR}$  range is referenced to the most positive side of the differential input signal.

**HSTL DC ELECTRICAL CHARACTERISTICS**

$V_{CC} = 2.375V$  to  $3.8V$ ;  $V_{EE} = 0V$

Symbol	Parameter	$T_A = -40^{\circ}C$			$T_A = +25^{\circ}C$			$T_A = +85^{\circ}C$			Unit
		Min.	Typ.	Max.	Min.	Typ.	Max.	Min.	Typ.	Max.	
$V_{IH}$	Input HIGH Voltage	1200	—	—	1200	—	—	1200	—	—	mV
$V_{IL}$	Input LOW Voltage	—	—	400	—	—	400	—	—	400	mV
$V_X$	Input Crossover Voltage	680	—	900	680	—	900	680	—	900	mV

### AC ELECTRICAL CHARACTERISTICS

(LVPECL)  $V_{CC} = 2.375$  to  $3.8V$ ,  $V_{EE} = 0V$ ; (LVECL)  $V_{EE} = -2.375V$  to  $-3.8V$ ,  $V_{CC} = 0V$

Symbol	Parameter	$T_A = -40^{\circ}C$			$T_A = +25^{\circ}C$			$T_A = +85^{\circ}C$			Unit	Condition
		Min.	Typ.	Max.	Min.	Typ.	Max.	Min.	Typ.	Max.		
$f_{MAX}$	Maximum Frequency <sup>(1)</sup>	3	—	—	3	—	—	3	—	—	GHz	
$t_{PD}$	Propagation Delay (Diff.)	250	350	400	250	350	400	250	350	400	ps	
$t_{SKEW}$	Within-Device Skew	—	20	25	—	20	25	—	20	25	ps	(2)
	Part-to-Part Skew	—	85	150	—	85	150	—	85	150	ps	(3)
$t_{JITTER}$	Cycle-to-Cycle Jitter (rms)	—	0.2	< 1	—	0.2	< 1	—	0.2	< 1	ps	
$V_{PP}$	Minimum Input Swing <sup>(4)</sup>	150	800	1200	150	800	1200	150	800	1200	mV	
$t_r, t_f$	Output Rise/Fall Time (20% to 80%)	100	170	250	100	170	250	100	170	250	ps	

**Note 1.** Measured with 750mV clock signal, 50% duty cycle. All loading with a 50Ω to  $V_{CC} - 2.0V$ .

**Note 2.** Input clock to any output (Q0 to Q9); Differential.

**Note 3.** Measured for same transitions.

**Note 4.** See "Timing Waveform."

### TIMING WAVEFORM



## TYPICAL CHARACTERISTICS

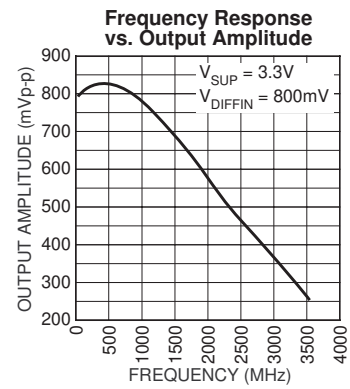
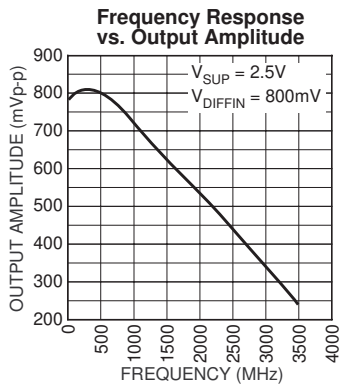



**TERMINATION RECOMMENDATIONS**

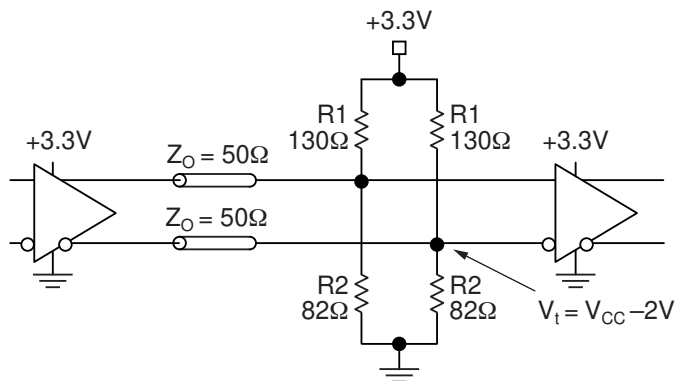

**Figure 1. Parallel Termination–Thevenin Equivalent**

**Note 1.** For +2.5V systems: R1 = 250Ω, R2 = 62.5Ω

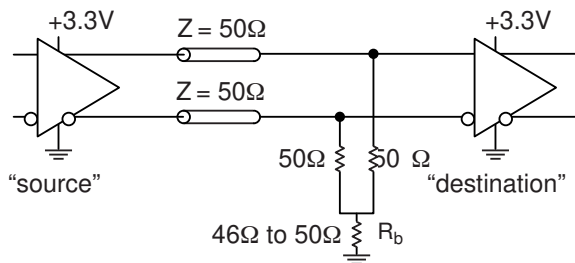

**Figure 2. Three-Resistor “Y-Termination”**

- Note 1.** Power-saving alternative to Thevenin termination.
- Note 2.** Place termination resistors as close to destination inputs as possible.
- Note 3.** R<sub>b</sub> resistor sets the DC bias voltage, equal to V<sub>t</sub>.

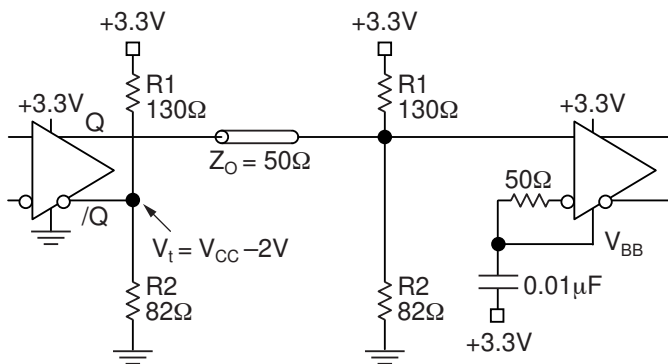

**Figure 3. Terminating Unused I/O**

- Note 1.** Unused output (/Q) must be terminated to balance the output.
- Note 2.** Micrel's differential I/O logic devices include a V<sub>BB</sub> reference pin .
- Note 3.** Connect unused input through 50Ω to V<sub>BB</sub>. Bypass with a 0.01μF capacitor to V<sub>CC</sub>, not GND.
- Note 4.** For +2.5V systems: R1 = 250Ω, R2 = 62.5Ω.

**32-PIN THIN QUAD FLATPACK (T32-1)**

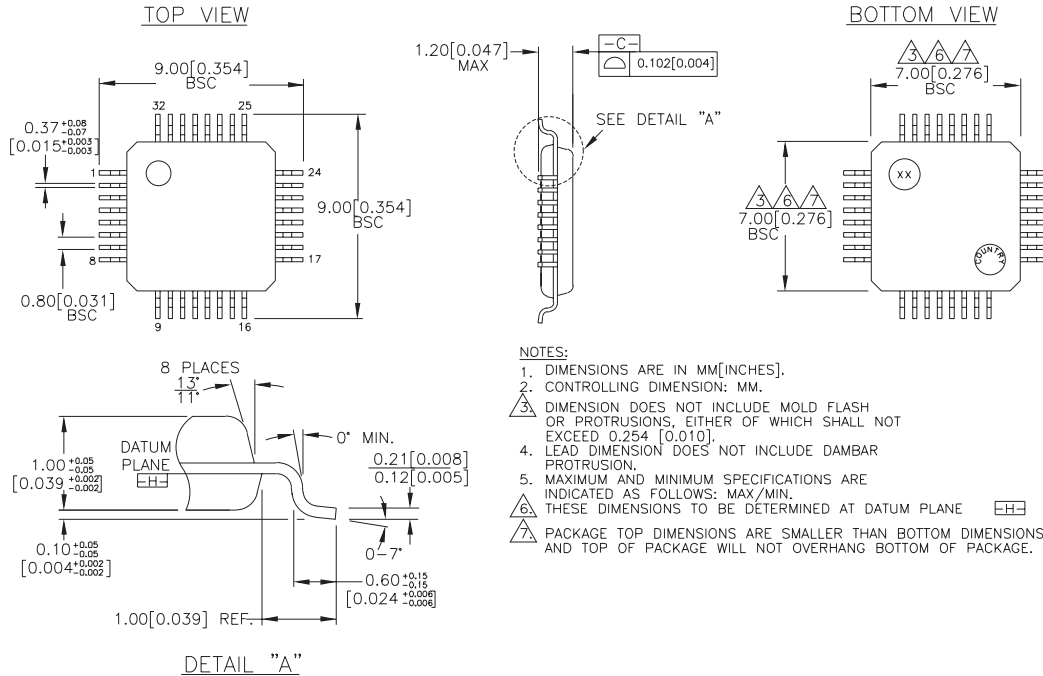

Rev. 01

**MICREL, INC. 2180 FORTUNE DRIVE SAN JOSE, CA 95131 USA**

TEL + 1 (408) 944-0800 FAX + 1 (408) 474-1000 WEB <http://www.micrel.com>

The information furnished by Micrel in this datasheet is believed to be accurate and reliable. However, no responsibility is assumed by Micrel for its use. Micrel reserves the right to change circuitry and specifications at any time without notification to the customer.

Micrel Products are not designed or authorized for use as components in life support appliances, devices or systems where malfunction of a product can reasonably be expected to result in personal injury. Life support devices or systems are devices or systems that (a) are intended for surgical implant into the body or (b) support or sustain life, and whose failure to perform can be reasonably expected to result in a significant injury to the user. A Purchaser's use or sale of Micrel Products for use in life support appliances, devices or systems is at Purchaser's own risk and Purchaser agrees to fully indemnify Micrel for any damages resulting from such use or sale.

© 2005 Micrel, Incorporated.