



Chipsmall Limited consists of a professional team with an average of over 10 year of expertise in the distribution of electronic components. Based in Hongkong, we have already established firm and mutual-benefit business relationships with customers from,Europe,America and south Asia,supplying obsolete and hard-to-find components to meet their specific needs.

With the principle of "Quality Parts,Customers Priority,Honest Operation,and Considerate Service",our business mainly focus on the distribution of electronic components. Line cards we deal with include Microchip,ALPS,ROHM,Xilinx,Pulse,ON,Everlight and Freescale. Main products comprise IC,Modules,Potentiometer,IC Socket,Relay,Connector.Our parts cover such applications as commercial,industrial, and automotives areas.

We are looking forward to setting up business relationship with you and hope to provide you with the best service and solution. Let us make a better world for our industry!



Contact us

Tel: +86-755-8981 8866 Fax: +86-755-8427 6832

Email & Skype: info@chipsmall.com Web: www.chipsmall.com

Address: A1208, Overseas Decoration Building, #122 Zhenhua RD., Futian, Shenzhen, China



FEATURES

- 25Ω cut-off bus outputs
- 50Ω receiver outputs
- Transmit and receive registers with separate clocks
- 1500ps max. delay from CLK1 to Bus Outputs (BUS)
- 1500ps max. delay from CLK2 to Receiver Outputs (Q)
- Individual bus enable pins
- Internal 75KΩ input pull-down resistors
- Voltage and temperature compensation for improved noise immunity
- Industry standard 100K ECL levels
- Extended supply voltage option:
VEE = -4.2V to -5.5V
- Available in 28-pin PLCC package

DESCRIPTION

The SY100S891 is a 5-bit registered transceiver containing five bus transceivers with both transmit and receive registers. The bus outputs (BUS0 – BUS4) are specified for driving a 25 ohm bus and the receive outputs (Q0 – Q4) are specified for driving a 50 ohm line. The bus outputs have a normal high level output voltage and a normal low level output voltage when the bus enable (BUSEN0 – BUSEN4) is high. However, the output is switched to a cut-off level when a bus-enable is low. This cut-off level is sufficiently low that a relatively high impedance is presented to the bus in order to minimize reflections. There is one bus-enable for each bus driver; a clock (CLK1) which is common to all five bus driver registers; and a separate clock (CLK2) which is common to all five receive registers. Data at the D inputs is clocked to the Bus register by a positive transition of CLK1 and data on the bus is clocked into the Receiver register by a positive transition of CLK2. A high on the Master Reset clears all registers.

PIN NAMES

Pin	Function
BUSEN0-4	Bus Enable Inputs
D0 – D4	Data Inputs
CLK1	Bus Driver Clock Input
CLK2	Receive Register Clock
MR	Master Reset
Q0 – Q4	Bus Receive Outputs
BUS0-4	Bus Outputs

PACKAGE/ORDERING INFORMATION

Ordering Information

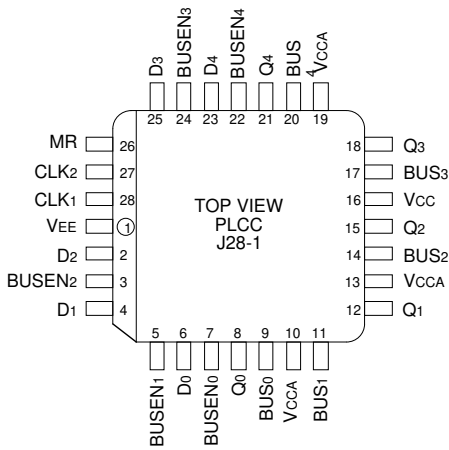

28-Pin PLCC (J28-1)

Part Number	Package Type	Operating Range	Package Marking	Lead Finish
SY100S891JC	J28-1	Commercial	SY100S891JC	Sn-Pb
SY100S891JCTR ⁽¹⁾	J28-1	Commercial	SY100S891JC	Sn-Pb
SY100S891JZ ⁽²⁾	J28-1	Commercial	SY100S891JC with Pb-Free bar-line indicator	Matte-Sn
SY100S891JZTR ^(1, 2)	J28-1	Commercial	SY100S891JC with Pb-Free bar-line indicator	Matte-Sn

Notes:

1. Tape and Reel.
2. Pb-Free package is recommended for new designs.

BLOCK DIAGRAM

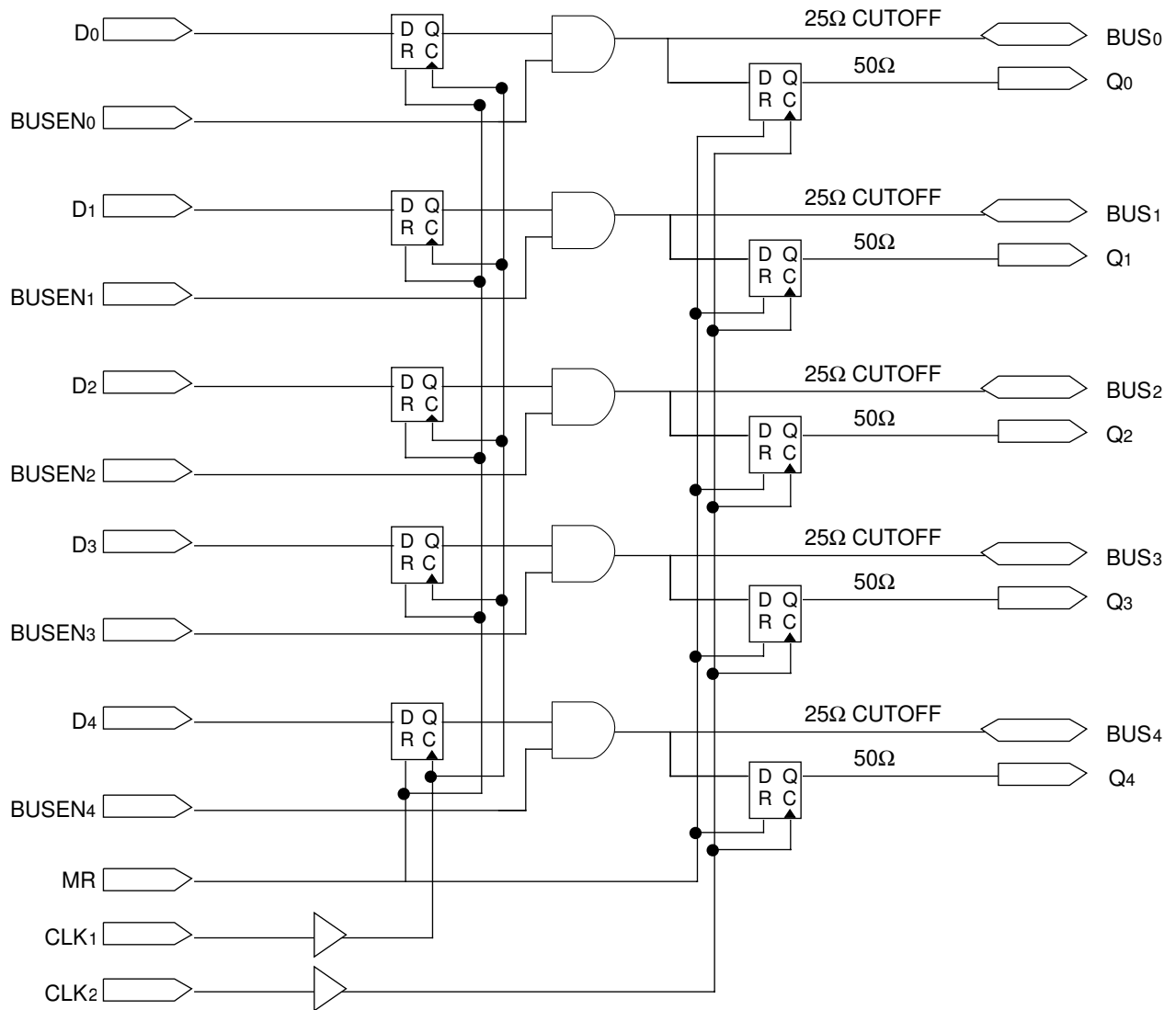

DC ELECTRICAL CHARACTERISTICS

$V_{EE} = -4.2V$ to $-5.5V$ unless otherwise specified; $V_{CC} = V_{CCA} = GND$

Symbol	Parameter	Min.	Typ.	Max.	Unit	Condition	
V _{CUT}	Cut-off Bus Output Voltage	-2200	-2160	-2100	mV	$V_{IN} = V_{IH} (Max.)$ or $V_{IL} (Min.)$	Loading with 25Ω to $-2.20V$
V _{OH}	Output HIGH Voltage Bus	-1025	-955	-880	mV	$V_{IN} = V_{IH} (Max.)$ or $V_{IL} (Min.)$	Loading with 25Ω to $-2.0V$
V _{OL}	Output LOW Voltage Bus	-1810	-1705	-1620	mV		
V _{OHA}	Output HIGH Voltage Bus	-1035	—	—	mV	$V_{IN} = V_{IH} (Min.)$ or $V_{IL} (Max.)$	
V _{OLA}	Output LOW Voltage Bus	—	—	-1610	mV		
V _{OH}	Output HIGH Voltage Receiver	-1025	-955	-880	mV	$V_{IN} = V_{IH} (Max.)$ or $V_{IL} (Min.)$	Loading with 50Ω to $-2.0V$
V _{OL}	Output LOW Voltage Receiver	-1810	-1705	-1620	mV		
V _{OHA}	Output HIGH Voltage Receiver	-1035	—	—	mV	$V_{IN} = V_{IH} (Min.)$ or $V_{IL} (Max.)$	
V _{OLA}	Output LOW Voltage Receiver	—	—	-1610	mV		
V _{IH}	Input HIGH Voltage	-1165	—	-880	mV	Guaranteed HIGH Signal for All Inputs	
V _{IL}	Input LOW Voltage	-1810	—	-1475	mV	Guaranteed LOW Signal for All Inputs	
I _{IL}	Input LOW Current	0.5	—	—	μA	$V_{IN} = V_{IL} (Min.)$	
I _{IH}	Input High Current	—	—	150	μA	$V_{IN} = V_{IH} (Max.)$	
I _{EE}	Power Supply Current	-216	—	—	mA	Inputs Open	
C _{IN}	Input Pin Capacitance	—	4	—	pF		
C _{OUT}	Output Pin Capacitance	—	5	—	pF		

AC ELECTRICAL CHARACTERISTICS

$V_{EE} = -4.2V$ to $-5.5V$ unless otherwise specified; $V_{CC} = V_{CCA} = GND$

Symbol	Parameter	$T_A = 0^\circ C$			$T_A = +25^\circ C$			$T_A = +85^\circ C$			Unit	Condition
		Min.	Typ.	Max.	Min.	Typ.	Max.	Min.	Typ.	Max.		
t _{PLH} t _{PHL}	Propagation Delay ⁽¹⁾ CLK ₁ to Bus	600	1000	1500	600	1000	1500	600	1000	1500	ps	
t _{PLH} t _{PHL}	Propagation Delay ⁽²⁾ CLK ₂ to Q	500	800	1200	500	800	1200	500	800	1200	ps	
t _{PLH} t _{PHL}	Propagation Delay ⁽¹⁾ BUSEN to Bus	500	800	1200	500	800	1200	500	800	1200	ps	
t _{PLH} t _{PHL}	Propagation Delay ⁽¹⁾ Master Reset to Bus	600	1000	1500	600	1000	1500	600	1000	1500	ps	
t _{PLH} t _{PHL}	Propagation Delay ⁽²⁾ Master Reset to Q	500	800	1200	500	800	1200	500	800	1200	ps	
t _S	Set-up Time Bus Wrt CLK ₂ D Wrt CLK ₁	— —	— —	400 400	— —	— —	400 400	— —	— —	400 400	ps	
t _{REL}	Master Reset Release Time	—	—	1000	—	—	1000	—	—	1000	ps	
t _H	Hold Time Bus Wrt CLK ₂ D Wrt CLK ₁	— —	— —	400 400	— —	— —	400 400	— —	— —	400 400	ps	
t _r	Output Rise Time Bus ⁽³⁾ Q ⁽⁴⁾	500 300	— —	1000 900	500 300	— —	1000 900	500 300	— —	1000 900	ps	
t _f	Output Fall Time Bus ⁽³⁾ Q ⁽⁴⁾	500 300	— —	1000 900	500 300	— —	1000 900	500 300	— —	1000 900	ps	
t _{skew}	Skew (Maximum difference between slowest and fastest path)	—	100	—	—	100	—	—	100	—	ps	

Notes:

1. Loaded with 25Ω to -2.0V
2. Loaded with 50Ω to -2.0V
3. 25Ω Load
4. 50Ω Load

28-PIN PLCC (J28-1)

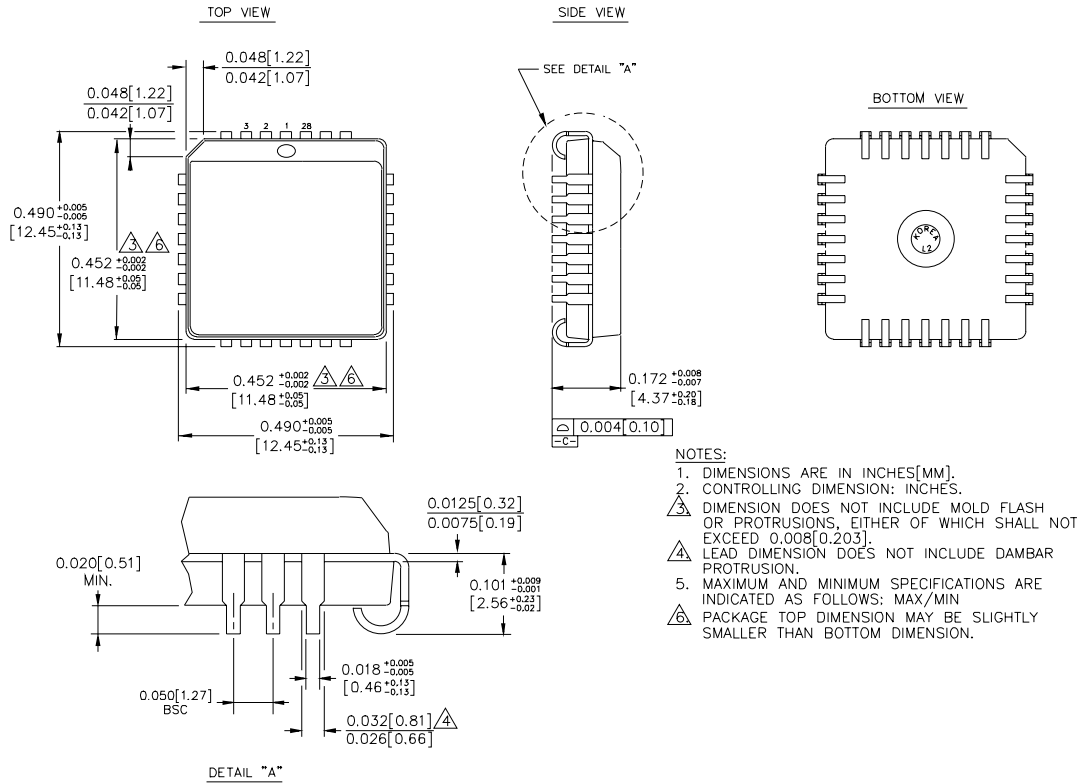

Rev. 03

MICREL, INC. 2180 FORTUNE DRIVE SAN JOSE, CA 95131 USA

TEL + 1 (408) 944-0800 FAX + 1 (408) 474-1000 WEB <http://www.micrel.com>

The information furnished by Micrel in this datasheet is believed to be accurate and reliable. However, no responsibility is assumed by Micrel for its use. Micrel reserves the right to change circuitry and specifications at any time without notification to the customer.

Micrel Products are not designed or authorized for use as components in life support appliances, devices or systems where malfunction of a product can reasonably be expected to result in personal injury. Life support devices or systems are devices or systems that (a) are intended for surgical implant into the body or (b) support or sustain life, and whose failure to perform can be reasonably expected to result in a significant injury to the user. A Purchaser's use or sale of Micrel Products for use in life support appliances, devices or systems is at Purchaser's own risk and Purchaser agrees to fully indemnify Micrel for any damages resulting from such use or sale.

© 2006 Micrel, Incorporated.