



Chipsmall Limited consists of a professional team with an average of over 10 year of expertise in the distribution of electronic components. Based in Hongkong, we have already established firm and mutual-benefit business relationships with customers from,Europe,America and south Asia,supplying obsolete and hard-to-find components to meet their specific needs.

With the principle of “Quality Parts,Customers Priority,Honest Operation,and Considerate Service”,our business mainly focus on the distribution of electronic components. Line cards we deal with include Microchip,ALPS,ROHM,Xilinx,Pulse,ON,Everlight and Freescale. Main products comprise IC,Modules,Potentiometer,IC Socket,Relay,Connector.Our parts cover such applications as commercial,industrial, and automotives areas.

We are looking forward to setting up business relationship with you and hope to provide you with the best service and solution. Let us make a better world for our industry!



Contact us

Tel: +86-755-8981 8866 Fax: +86-755-8427 6832

Email & Skype: info@chipsmall.com Web: www.chipsmall.com

Address: A1208, Overseas Decoration Building, #122 Zhenhua RD., Futian, Shenzhen, China





6-BIT D REGISTER

**SY10E151
SY100E151**

FEATURES

- 1100MHz toggle frequency
- Extended 100E VEE range of -4.2V to -5.46V
- Differential outputs
- Asynchronous Master Reset
- Dual clocks
- Fully compatible with industry standard 10KH, 100K ECL levels
- Internal 75KΩ input pulldown resistors
- Fully compatible with Motorola MC10E/100E151
- Available in 28-pin PLCC package

DESCRIPTION

The SY10/100E151 offer 6 edge-triggered, high-speed, master-slave D-type flip-flops with differential outputs, designed for use in new, high-performance ECL systems. The two external clock signals (CLK1, CLK2) are gated through a logical OR operation before use as clocking control for the flip-flops. Data is clocked into the flip-flops on the rising edge of either CLK1 or CLK2 (or both). When both CLK1 and CLK2 are at a logic LOW, data enters the master and is transferred to the slave when either CLK1 or CLK2 (or both) go HIGH.

The MR (Master Reset) signal operates asynchronously to make all Q outputs go to a logic LOW.

BLOCK DIAGRAM

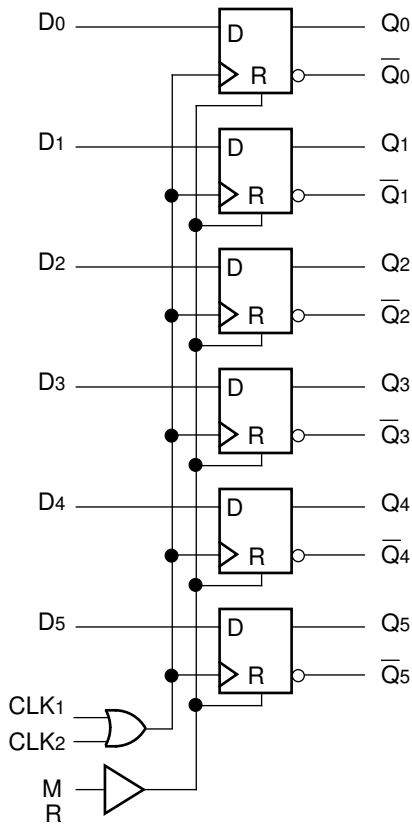

PIN NAMES

Pin	Function
D0-D5	Data Inputs
CLK1, CLK2	Clock Inputs
MR	Master Reset
Q0-Q5	True Outputs
Q̄0-Q̄5	Inverting Outputs
Vcco	Vcc to Output

PACKAGE/ORDERING INFORMATION

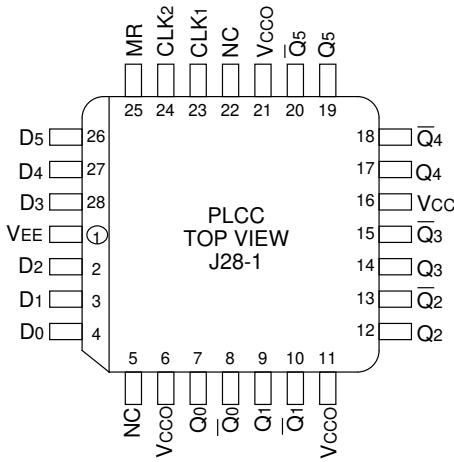

28-Pin PLCC (J28-1)

Ordering Information⁽¹⁾

Part Number	Package Type	Operating Range	Package Marking	Lead Finish
SY10E151JI	J28-1	Industrial	SY10E151JI	Sn-Pb
SY10E151JITR ⁽²⁾	J28-1	Industrial	SY10E151JI	Sn-Pb
SY10E151JC	J28-1	Commercial	SY10E151JC	Sn-Pb
SY10E151JCTR ⁽²⁾	J28-1	Commercial	SY10E151JC	Sn-Pb
SY100E151JC	J28-1	Commercial	SY100E151JC	Sn-Pb
SY100E151JCTR ⁽²⁾	J28-1	Commercial	SY100E151JC	Sn-Pb
SY10E151JY ⁽³⁾	J28-1	Industrial	SY10E151JY with Pb-Free bar-line indicator	Matte-Sn
SY10E151JYTR ^(2, 3)	J28-1	Industrial	SY10E151JY with Pb-Free bar-line indicator	Matte-Sn
SY100E151JZ ⁽³⁾	J28-1	Commercial	SY100E151JZ with Pb-Free bar-line indicator	Matte-Sn
SY100E151JZTR ^(2, 3)	J28-1	Commercial	SY100E151JZ with Pb-Free bar-line indicator	Matte-Sn

Notes:

1. Contact factory for die availability. Dice are guaranteed at T_A = 25°C, DC Electricals only.
2. Tape and Reel.
3. Pb-Free package is recommended for new designs.

TRUTH TABLES⁽¹⁾

Asynchronous Operation

Inputs				Output
D _n	CLK ₁	CLK ₂	MR	Q _n (t + 1)
X	X	X	H	L

Note:

- 1. H = HIGH Voltage Level
- L = LOW Voltage Level
- X = Don't Care
- t = Time before positive CLK transition
- t+1 = Time after positive CLK transition
- u = LOW-to-HIGH transition

Synchronous Operation

Inputs				Output
D _n	CLK ₁	CLK ₂	MR	Q _n (t + 1)
L	u	L	L	L
H	u	L	L	H
L	L	u	L	L
H	L	u	L	H
X	H	u	L	Q _n (t)
X	u	H	L	Q _n (t)
X	L	L	L	Q _n (t)

DC ELECTRICAL CHARACTERISTICS⁽¹⁾

V_{EE} = V_{EE} (Min.) to V_{EE} (Max.); V_{CC} = V_{CCO} = GND

Symbol	Parameter	T _A = 0°C			T _A = +25°C			T _A = +85°C			Unit	Condition
		Min.	Typ.	Max.	Min.	Typ.	Max.	Min.	Typ.	Max.		
I _{IH}	Input HIGH Current	—	—	150	—	—	150	—	—	150	μA	—
I _{EE}	Power Supply Current	—	65	78	—	65	78	—	65	78	mA	—
		10E	65	78	—	65	78	—	65	78		
		100E	65	78	—	65	78	—	75	90		

Note:

- 1. Specification for packaged product only.

AC ELECTRICAL CHARACTERISTICS⁽²⁾

V_{EE} = V_{EE} (Min.) to V_{EE} (Max.); V_{CC} = V_{CCO} = GND

Symbol	Parameter	T _A = 0°C			T _A = +25°C			T _A = +85°C			Unit	Condition
		Min.	Typ.	Max.	Min.	Typ.	Max.	Min.	Typ.	Max.		
f _{MAX}	Max. Toggle Frequency	1100	1400	—	1100	1400	—	1100	1400	—	MHz	—
t _{PD}	Propagation Delay to Output CLK MR	475	650	800	475	650	800	475	650	800	ps	—
		475	650	850	475	650	850	475	650	850		
t _S	Set-up Time, D	0	-175	—	0	-175	—	0	-175	—	ps	—
t _H	Hold Time, D	350	175	—	350	175	—	350	175	—	ps	—
t _{RR}	Reset Recovery Time	750	550	—	750	550	—	750	550	—	ps	—
t _{PW}	Minimum Pulse Width CLK, MR	400	—	—	400	—	—	400	—	—	ps	—
t _{skew}	Within-Device Skew	—	65	—	—	65	—	—	65	—	ps	1
t _r t _f	Rise/Fall Time 20% to 80%	300	450	700	300	450	700	300	450	700	ps	—

Note:

- 1. Within-device skew is defined as identical transitions on similar paths through a device.
- 2. Specification for packaged product only.

28-PIN PLCC (J28-1)

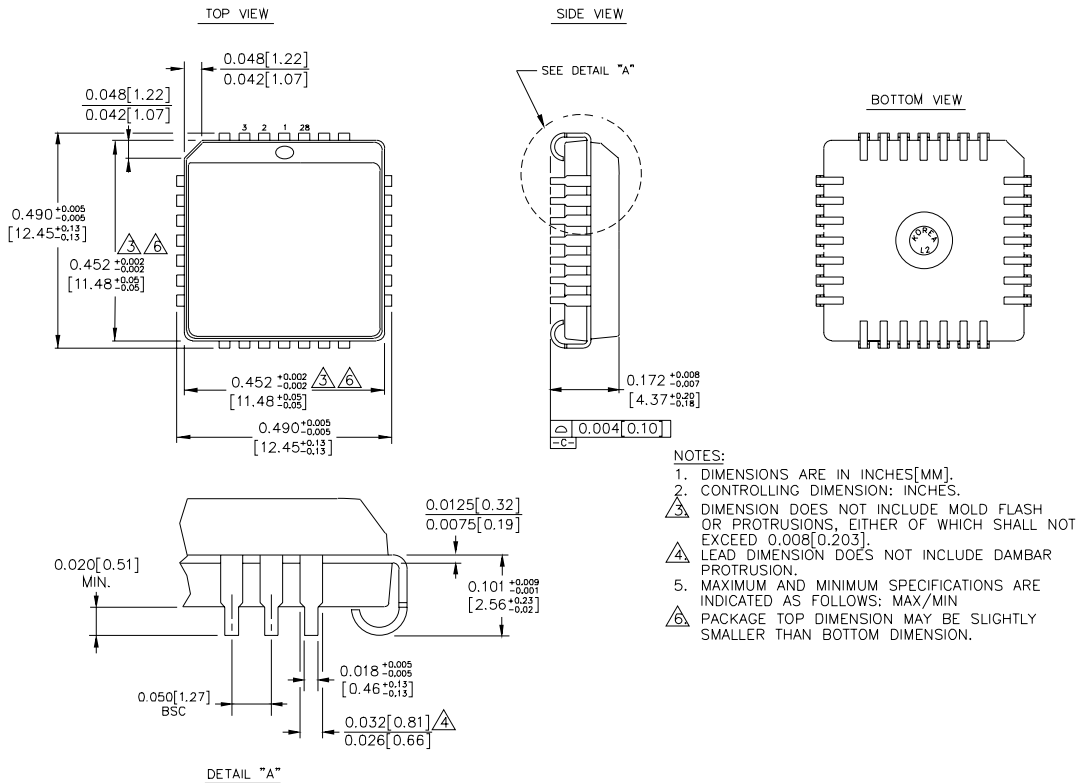

Rev. 03

MICREL, INC. 2180 FORTUNE DRIVE SAN JOSE, CA 95131 USA

TEL + 1 (408) 944-0800 FAX + 1 (408) 474-1000 WEB <http://www.micrel.com>

The information furnished by Micrel in this data sheet is believed to be accurate and reliable. However, no responsibility is assumed by Micrel for its use. Micrel reserves the right to change circuitry and specifications at any time without notification to the customer.

Micrel Products are not designed or authorized for use as components in life support appliances, devices or systems where malfunction of a product can reasonably be expected to result in personal injury. Life support devices or systems are devices or systems that (a) are intended for surgical implant into the body or (b) support or sustain life, and whose failure to perform can be reasonably expected to result in a significant injury to the user. A Purchaser's use or sale of Micrel Products for use in life support appliances, devices or systems is at Purchaser's own risk and Purchaser agrees to fully indemnify Micrel for any damages resulting from such use or sale.

© 2006 Micrel, Incorporated.