

Chipsmall Limited consists of a professional team with an average of over 10 year of expertise in the distribution of electronic components. Based in Hongkong, we have already established firm and mutual-benefit business relationships with customers from,Europe,America and south Asia,supplying obsolete and hard-to-find components to meet their specific needs.

With the principle of “Quality Parts,Customers Priority,Honest Operation,and Considerate Service”,our business mainly focus on the distribution of electronic components. Line cards we deal with include Microchip,ALPS,ROHM,Xilinx,Pulse,ON,Everlight and Freescale. Main products comprise IC,Modules,Potentiometer,IC Socket,Relay,Connector.Our parts cover such applications as commercial,industrial, and automotives areas.

We are looking forward to setting up business relationship with you and hope to provide you with the best service and solution. Let us make a better world for our industry!



Contact us

Tel: +86-755-8981 8866 Fax: +86-755-8427 6832

Email & Skype: info@chipsmall.com Web: www.chipsmall.com

Address: A1208, Overseas Decoration Building, #122 Zhenhua RD., Futian, Shenzhen, China



**2.5V/3V, 3.0GHz CML
AnyGate® ANY LOGIC
WITH 50Ω or 100Ω OUTPUTS**

**SuperLite™
SY55851
SY55851A**

FEATURES

- **Guaranteed AC parameters over temperature:**
 - $f_{MAX} > 3.0\text{GHz}$ (SY55851A)
 - $t_r / t_f < 100\text{ps}$
 - Propagation delay $< 280\text{ps}$
- **Guaranteed operation over -40°C to $+85^\circ\text{C}$ temperature range**
- **Wide supply voltage range: 2.3V to 3.6V**
- **Single IC provides 8 logic functions**
- **2:1 MUX capability**
- **Fully differential I/O**
- **Source terminated CML outputs for fast edge rates:**
 - SY55851 for 100Ω load
 - SY55851A for 50Ω load
- **Guaranteed matched propagation delays:**
 - Select (S)-to-out: $< 280\text{ps}$
 - Input (A and B)-to-out: $< 280\text{ps}$
- **Accepts PECL, LVPECL, CML input signals**
- **Functions as a PECL/LVPECL-to-CML translator**
- **Available in a 10-pin (3mm × 3mm) MSOP package**



SuperLite™

DESCRIPTION

The SY55851 and SY55851A are highly flexible, universal logic gates capable of up to 3.0GHz operation (SY55851A). These AnyGate® differential logic devices will produce all possible logic functions of two Boolean variables. They can be configured as any of the following gates: AND, NAND, OR, NOR, XOR, XNOR, DELAY, NEGATION (NOT). The SY55851 and SY55851A can also function as a 2-input multiplexer.

The SY55851 has an output stage optimized for 100Ω loads, and the SY55851A is optimized for 50Ω loads. The differential inputs for both devices are normally terminated with a single resistor (100Ω) between the true and complement pins.

APPLICATIONS

- **Port bypass**
- **Data communication systems**
- **Wireless communication systems**
- **Telecom systems**

FUNCTIONAL BLOCK DIAGRAM

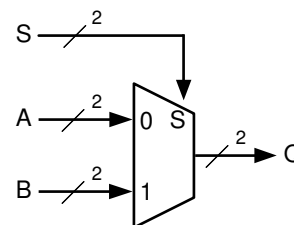

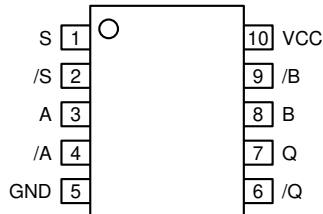
PACKAGE/ORDERING INFORMATION**8-Pin MSOP (K10-1)****Ordering Information⁽¹⁾**

Part Number	Package Type	Operating Range	Package Marking	Lead Finish
SY55851UKI	K10-1	Industrial	851U	Sn-Pb
SY55851UKITR ⁽²⁾	K10-1	Industrial	851U	Sn-Pb
SY55851AUKI	K10-1	Industrial	851A	Sn-Pb
SY55851AUKITR ⁽²⁾	K10-1	Industrial	851A	Sn-Pb
SY55851UKG ⁽³⁾	K10-1	Industrial	851U with Pb-Free bar-line indicator	Pb-Free NiPdAu
SY55851UKGTR ^(2, 3)	K10-1	Industrial	851U with Pb-Free bar-line indicator	Pb-Free NiPdAu
SY55851AUKG ⁽³⁾	K10-1	Industrial	851A with Pb-Free bar-line indicator	Pb-Free NiPdAu
SY55851AUKGTR ^(2, 3)	K10-1	Industrial	851A with Pb-Free bar-line indicator	Pb-Free NiPdAu

Notes:

1. Contact factory for die availability. Dice are guaranteed at $T_A = 25^\circ\text{C}$, DC Electricals only.
2. Tape and Reel.
3. Pb-Free package recommended for new designs.

PIN DESCRIPTION

Pin Number	Pin Name	Pin Function
1, 2	S, /S	CML, PECL, LVPECL Input Selector: This differential CML input is one of the inputs to the logic block. It represents either one Boolean input for a 2-variable logic function, or the select input for a 2-input MUX.
3, 4	A, /A	CML, PECL, LVPECL Input: This is one of the differential inputs to the logic block. For a 2-variable logic function, it is either a constant value or a Boolean input. For a 2-input MUX, this signal represents the output when S is set to logic zero.
5	GND	Ground.
6, 7	/Q, Q	Differential CML Output: This is the differential CML output for the logic block. For termination guidelines, see Figure 3.
8, 9	B, /B	CML, PECL, LVPECL Input: This is one of the differential inputs to the logic block. For a 2-variable logic function, it is either a constant value or a Boolean input. For a 2-input MUX, this signal represents the output when S is set to logic one.
10	VCC	V_{CC} .

FUNCTIONAL DESCRIPTION

Establishing Static Logic Inputs

The true pin of an input pair is internally biased to ground through a 75kΩ resistor. The complement pin of an input pair is internally biased to $V_{CC}/2$ through an internal voltage divider consisting of two 75kΩ resistors. Since some logic functions necessitate an output to be connected to two inputs, SY55851/A inputs have no internal terminations. Typically, one resistor between the true and complement input is all that is required, as per **Figure 3**. To keep an

input at static logic zero at $V_{CC} \geq 3.0V$, leave both inputs unconnected or tie the complement input to V_{CC} . For $V_{CC} < 3.0V$ applications, connect the complement input to V_{CC} and leave the true input unconnected. To make an input static logic one, connect the true input to V_{CC} , and leave the complement input unconnected. These are the only safe ways to cause inputs to be at a static value. In particular, no input pin should be directly connected to ground. All NC (no connect) pins should be unconnected.

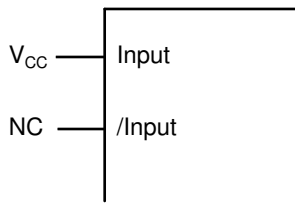

Figure 1. Hard Wiring A Logic “1” (1)

Note 1. Input is either A, B, S input, and /Input is either /A, /B, /S input.

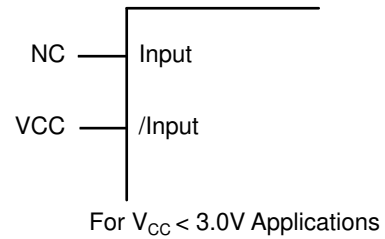
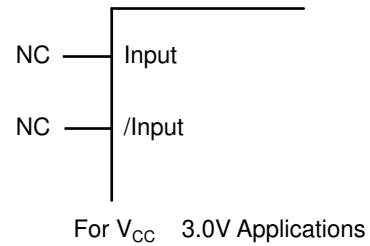
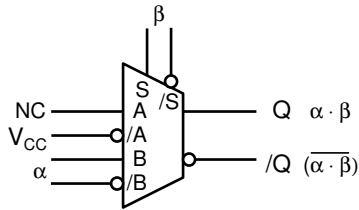

Figure 2. Hard Wiring A Logic “0” (1)

TRUTH TABLES



AND/NAND

A	α B	β S	$\alpha \cdot \beta$ Q	$\overline{(\alpha \cdot \beta)}$ /Q
L	L	L	L	H
L	H	L	L	H
L	L	H	L	H
L	H	H	H	L

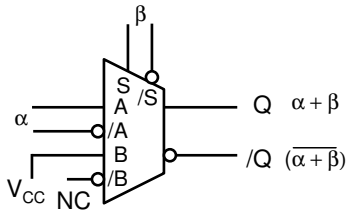

OR/NOR

α A	B	β S	$\alpha + \beta$ Q	$\overline{(\alpha + \beta)}$ /Q
L	H	L	L	H
H	H	L	H	L
L	H	H	H	L
H	H	H	H	L

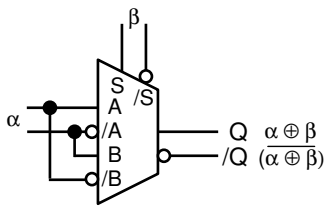

XOR/XNOR

α A	B	β S	$\alpha \oplus \beta$ Q	$\overline{(\alpha \oplus \beta)}$ /Q
L	H	L	L	H
L	H	H	H	L
H	L	L	H	L
H	L	H	L	H

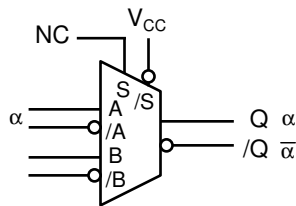

DELAY/NEGATION

α A	B	S	α Q	$\bar{\alpha}$ /Q
L	X	L	L	H
H	X	L	H	L

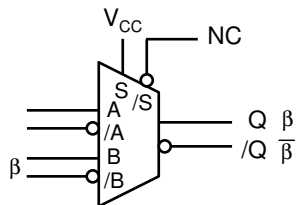

A	β B	S	β Q	$\bar{\beta}$ /Q
X	L	H	L	H
X	H	H	H	L

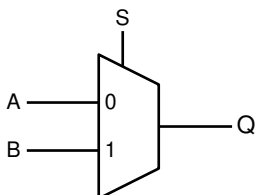

2:1 MUX

S	Q	/Q
H	B	/B
L	A	/A

CML TERMINATION AND TTL INTERFACE

All inputs accept the output from any other member of this family. All outputs are source terminated 100Ω or 50Ω CML differential drivers as shown in Figure 3. All inputs to the SY55851/A must be externally terminated. SY55851/A

inputs are designed to accept a termination resistor between the true and complement inputs of a differential pair. 0402 form factor chip resistors will fit with some trace fanout.

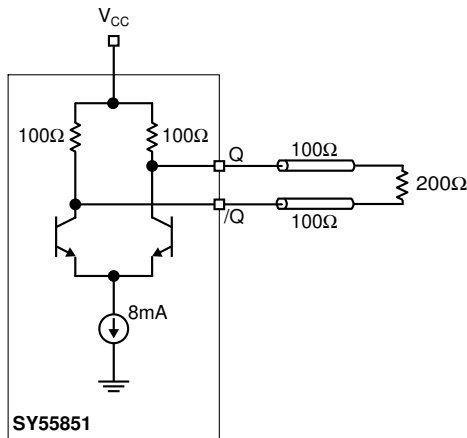

Figure 3a. SY55851 (100Ω Load CML Output)

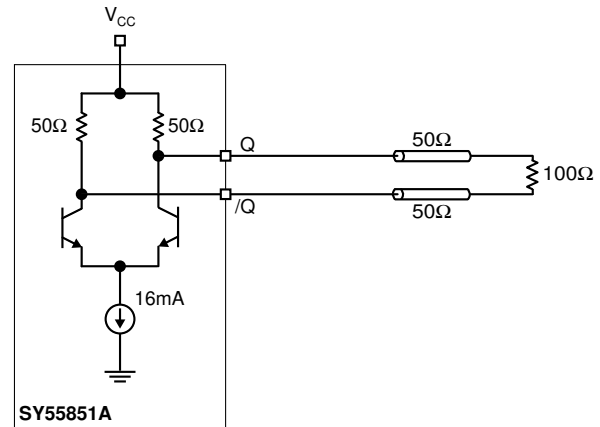

Figure 3b. Differentially Terminated SY55851A (50Ω Load CML Output)

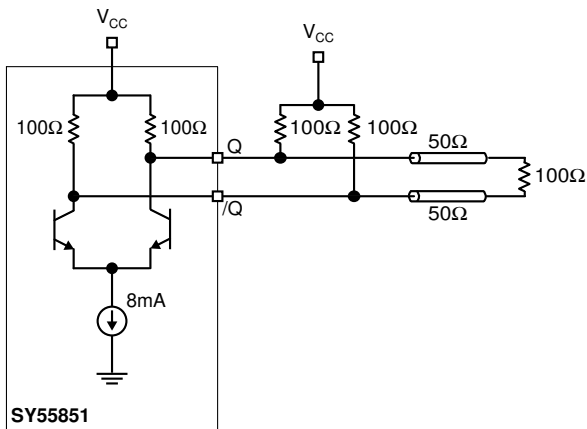

Figure 3c. Differentially Terminated SY55851 (50Ω Load CML Output)

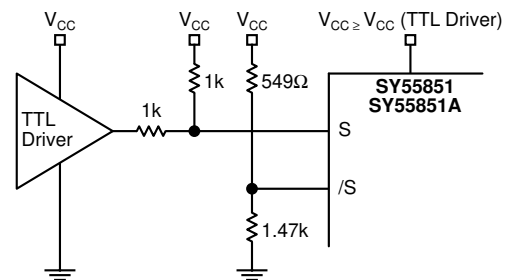

Figure 4. Interfacing TTL-to-CML Select Inputs

ABSOLUTE MAXIMUM RATINGS⁽¹⁾

Symbol	Rating	Value	Unit	
V _{CC}	Power Supply Voltage	-0.5 to +6.0	V	
V _{IN}	Input Voltage	-0.5 to V _{CC} +0.5	V	
V _{OUT}	CML Output Voltage	V _{CC} -1.0 to V _{CC} +0.5	V	
T _A	Operating Temperature Range	-40 to +85	°C	
T _{LEAD}	Lead Temperature (soldering, 20sec.)	260	°C	
T _{store}	Storage Temperature Range	-65 to +150	°C	
θ _{JA}	Package Thermal Resistance (Junction-to-Ambient)	-Still-Air (multi-layer PCB)	113	°C/W
		-500lfpm (multi-layer PCB)	96	°C/W
θ _{JC}	Package Thermal Resistance (Junction-to-Case)	42	°C/W	

Note 1. Permanent device damage may occur if absolute maximum ratings are exceeded. This is a stress rating only and functional operation is not implied at conditions other than those detailed in the operational sections of this data sheet. Exposure to absolute maximum rating conditions for extended periods may affect device reliability.

DC ELECTRICAL CHARACTERISTICS

T_A = -40°C to +85°C⁽²⁾

Symbol	Parameter	Min.	Typ.	Max.	Unit	Condition
V _{CC}	Power Supply Voltage	2.3	—	3.6	V	
I _{CC}	Power Supply Current					
	SY55851	—	—	40	mA	No Load
	SY55851A	—	46	60	mA	No Load

CML DC ELECTRICAL CHARACTERISTICS

V_{CC} = 2.3V to 3.6V; GND = 0V; T_A = -40°C to +85°C

Symbol	Parameter	Min.	Typ.	Max.	Unit	Condition
V _{ID}	Differential Input Voltage	100	—	—	mV	
V _{IH}	Input HIGH Voltage	1.6	—	V _{CC}	V	
V _{IL}	Input LOW Voltage	1.5	—	V _{CC} - 0.1	V	
V _{OH}	Output HIGH Voltage	V _{CC} - 0.040	V _{CC} - 0.010	V _{CC}	V	No Load
V _{OL}	Output LOW Voltage	V _{CC} - 1.00	V _{CC} - 0.800	V _{CC} - 0.65	V	No Load
V _{OUT}	Output Voltage Swing ⁽³⁾	0.650	0.800	1.00	V	No Load
	SY55851	—	0.400	—	V	100Ω Load ⁽⁴⁾
		—	0.200	—	V	50Ω Load ⁽⁵⁾ (SY55851)
	SY55851A	—	0.400	—	V	50Ω Load ⁽⁶⁾ (SY55851A)
R _{OUT}	Output Source Impedance					
	SY55851	80	100	120	Ω	
	SY55851A	40	50	60	Ω	

Note 2. The DC parameters are guaranteed after thermal equilibrium has been established.

Note 3. Actual voltage levels and differential swing will depend on customer termination scheme. Refer to the "CML Termination" diagram for more details.

Note 4. Applies to SY55851: 200Ω termination resistor across Q and /Q. See **Figure 3a**.

Note 5. Applies to the SY55851. See **Figure 3c**.

Note 6. Applies to the SY55851A: 100Ω termination resistor across Q and /Q. See **Figure 3b**.

AC ELECTRICAL CHARACTERISTICS(1, 2) $V_{CC} = 2.3V$ to $3.6V$; $GND = 0V$; $T_A = -40^{\circ}C$ to $+85^{\circ}C$

Symbol	Parameter	Min.	Typ.	Max.	Unit	Condition
$f_{MAX}^{(3)}$	Max. Operating Frequency					
	SY55851	2.5	—	—	GHz	
	SY55851A	3.0	—	—	GHz	
$t_{PD(S-Q)}$	Propagation Delay (S to Q)					
	SY55851	—	—	350	ps	
	SY55851A	130	—	280	ps	
t_{PD} (A-Q and B-Q)	Propagation Delay (A-Q and B-Q)					
	SY55851	—	—	350	ps	
	SY55851A	130	—	280	ps	
t_r t_f	CML Output Rise/Fall Times (20% to 80%)	SY55851	—	—	110	ps
		SY55851A	—	65	100	ps

Note 1. SY55851: outputs terminated to 50Ω equivalent load. See **Figure 3c**.SY55851A: outputs terminated to 50Ω load. See **Figure 3b****Note 2.** Specification for packaged product only.**Note 3.** f_{MAX} represents a maximum toggle rate in which the output still meets CML logic swing.

10-PIN MSOP (K10-1)

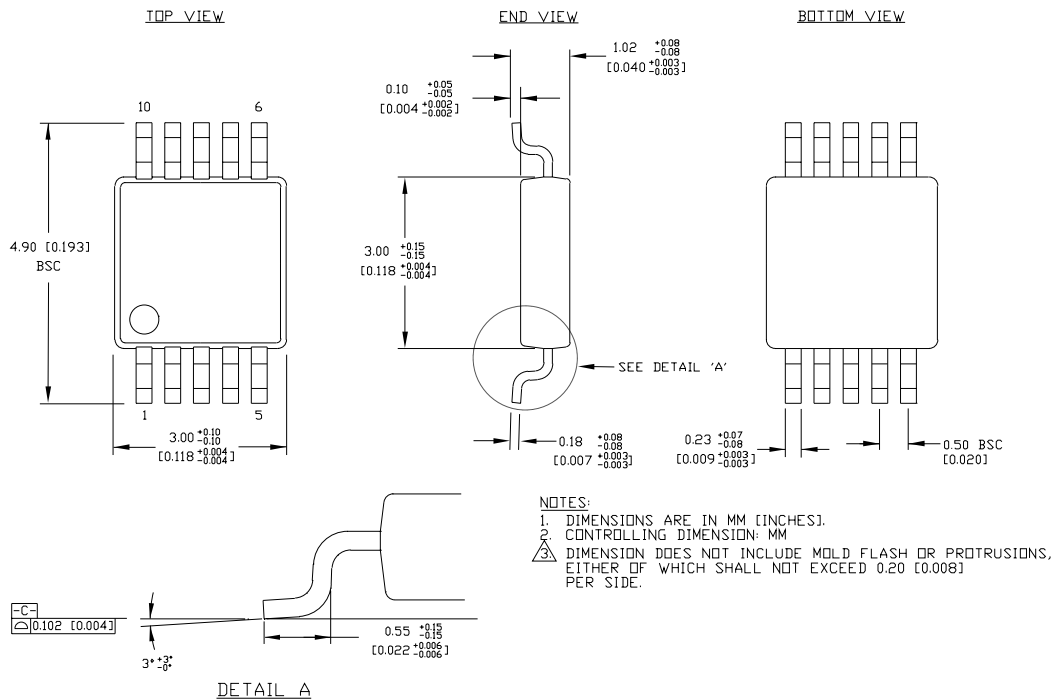

Rev. 00

MICREL, INC. 2180 FORTUNE DRIVE SAN JOSE, CA 95131 USA

TEL + 1 (408) 944-0800 FAX + 1 (408) 474-1000 WEB <http://www.micrel.com>

The information furnished by Micrel in this datasheet is believed to be accurate and reliable. However, no responsibility is assumed by Micrel for its use. Micrel reserves the right to change circuitry and specifications at any time without notification to the customer.

Micrel Products are not designed or authorized for use as components in life support appliances, devices or systems where malfunction of a product can reasonably be expected to result in personal injury. Life support devices or systems are devices or systems that (a) are intended for surgical implant into the body or (b) support or sustain life, and whose failure to perform can be reasonably expected to result in a significant injury to the user. A Purchaser's use or sale of Micrel Products for use in life support appliances, devices or systems is at Purchaser's own risk and Purchaser agrees to fully indemnify Micrel for any damages resulting from such use or sale.

© 2005 Micrel, Incorporated.