



Chipsmall Limited consists of a professional team with an average of over 10 year of expertise in the distribution of electronic components. Based in Hongkong, we have already established firm and mutual-benefit business relationships with customers from,Europe,America and south Asia,supplying obsolete and hard-to-find components to meet their specific needs.

With the principle of "Quality Parts,Customers Priority,Honest Operation,and Considerate Service",our business mainly focus on the distribution of electronic components. Line cards we deal with include Microchip,ALPS,ROHM,Xilinx,Pulse,ON,Everlight and Freescale. Main products comprise IC,Modules,Potentiometer,IC Socket,Relay,Connector.Our parts cover such applications as commercial,industrial, and automotives areas.

We are looking forward to setting up business relationship with you and hope to provide you with the best service and solution. Let us make a better world for our industry!



## Contact us

Tel: +86-755-8981 8866 Fax: +86-755-8427 6832

Email & Skype: info@chipsmall.com Web: www.chipsmall.com

Address: A1208, Overseas Decoration Building, #122 Zhenhua RD., Futian, Shenzhen, China



**FEATURES**

- Selects 1 of 4 differential inputs
- Provides two copies of the selected input
- Guaranteed AC performance over temperature and voltage:
  - DC-to- > 10.7Gbps data rate throughput
  - < 350ps IN-to-Out  $t_{pd}$
  - < 60ps  $t_r / t_f$  times
- Ultra low-jitter design:
  - < 10ps<sub>pp</sub> total jitter (clock)
  - < 1ps<sub>RMS</sub> random jitter
  - < 10ps<sub>pp</sub> deterministic jitter
  - < 0.7ps<sub>RMS</sub> crosstalk-induced jitter
- Unique patented input design minimizes crosstalk
- Accepts an input signal as low as 100mV
- Unique patented input termination and  $V_T$  pin accepts DC- and AC-coupled inputs (CML, LVPECL, LVDS)
- Internal 50Ω output source termination
- 400mV CML output swing ( $R_L = 50\Omega$ )
- Power supply 2.5V ±5% or 3.3V ±10%
- -40°C to +85°C temperature range
- Available in 32-pin (5mm × 5mm) MLF® package



Precision Edge®

**DESCRIPTION**

The SY58028U is a 2.5V/3.3V precision, high-speed, 4:1 differential CML multiplexer capable of handling clocks up to 7GHz and data streams up to 10.7Gbps. In addition, a 1:2 fanout buffer provides two copies of the selected inputs.

The differential input includes Micrel's unique, 3-pin input termination architecture that allows customers to interface to any differential signal (AC- or DC-coupled) as small as 100mV without any level shifting or termination resistor networks in the signal path. The result is a clean, stub-free, low-jitter interface solution. The outputs are 50Ω source terminated CML, with extremely fast rise/fall times guaranteed to be less than 60ps.

The SY58028U operates from a 2.5V ±5% supply or a 3.3V ±10% supply and is guaranteed over the full industrial temperature range of -40°C to +85°C. For applications that require LVPECL outputs, consider the SY58029U or SY58030U Multiplexers. The SY58028U is part of Micrel's high-speed, Precision Edge® product line.

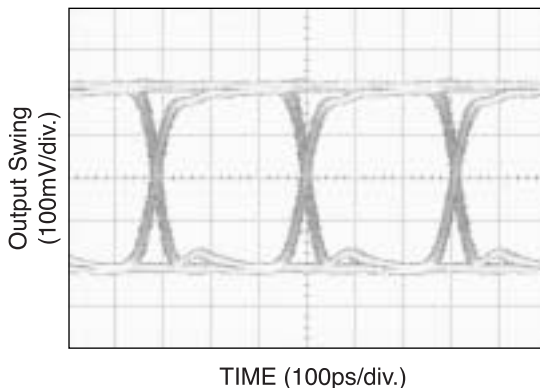
All support documentation can be found on Micrel's web site at [www.micrel.com](http://www.micrel.com).

**APPLICATIONS**

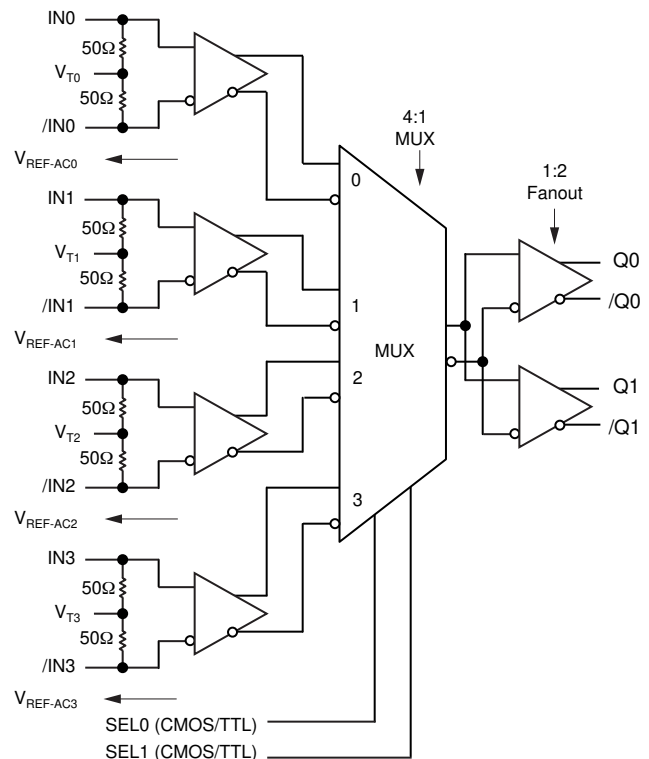
- Redundant clock and/or data distribution
- All SONET/SDH clock/data distribution
- Loopback
- All Fibre Channel distribution
- All Gigabit Ethernet clock and/or data distribution

**TYPICAL PERFORMANCE**

3.2Gbps Output ( $2^{23}-1$  PRBS)

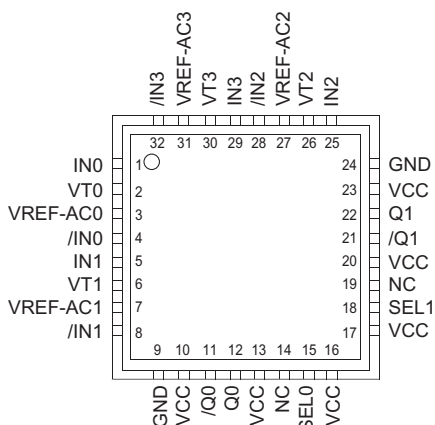


**FUNCTIONAL BLOCK DIAGRAM**



Precision Edge is a registered trademark of Micrel, Inc.  
MicroLeadFrame and MLF are registered trademarks of Amkor Technology, Inc.

**PACKAGE/ORDERING INFORMATION**



**32-Pin MLF® (MLF-32)**

**Ordering Information<sup>(1)</sup>**

Part Number	Package Type	Operating Range	Package Marking	Lead Finish
SY58028UMI	MLF-32	Industrial	SY58028U	Sn-Pb
SY58028UMITR <sup>(2)</sup>	MLF-32	Industrial	SY58028U	Sn-Pb
SY58028UMG <sup>(3)</sup>	MLF-32	Industrial	SY58028U with Pb-Free bar-line indicator	Pb-Free NiPdAu
SY58028UMGTR <sup>(2, 3)</sup>	MLF-32	Industrial	SY58028U with Pb-Free bar-line indicator	Pb-Free NiPdAu

**Notes:**

1. Contact factory for die availability. Dice are guaranteed at  $T_A = 25^\circ\text{C}$ , DC electricals only.
2. Tape and Reel.
3. Pb-Free package recommended for new designs.

**PIN DESCRIPTION**

Pin Number	Pin Name	Pin Function
1, 4 5, 8 25, 28 29, 32	IN0, /IN0 IN1, /IN1 IN2, /IN2 IN3, /IN3	Differential Inputs: These inputs accept AC- or DC-coupled signals as small as 100mV. Each pin of a pair internally terminates to a $V_T$ pin through 50Ω. Note that these inputs will default to an indeterminate state if left open. If an input pair is not used, connect one input of the pair to ground through a 1kΩ resistor and the complement to $V_{CC}$ through a 825Ω resistor. Unused $V_T$ and $V_{REF-AC}$ may also be left open. Please refer to the “Input Interface Applications” section for more details.
2, 6, 26, 30	VT0, VT1 VT2, VT3	Input Termination Center-Tap: Each side of the differential input pair terminates to a $V_T$ pin. The $V_T$ pin provides a center-tap to the termination network for maximum interface flexibility. See “Input Interface Applications” section for more details.
15, 18	SEL0, SEL1	This single-ended TTL/CMOS compatible input selects the inputs to the multiplexer. Note that this input is internally connected to a 25kΩ pull-up resistor and will default to a logic HIGH state if left open. Input logic threshold is $V_{CC}/2$ . See “Truth Table” for select control.
14, 19	NC	No Connect.
10, 13, 16 17, 20, 23	VCC	Positive Power Supply: Bypass with 0.1μF    0.01μF low ESR capacitors.
11, 12 21, 22	/Q0, Q0 /Q1, Q1	Differential Outputs: These CML output pairs are copies of the selected input. Unused output pairs may be left floating. See “Output Interface” section for termination guidelines.
9, 24	GND, Exposed Pad	Ground. Ground pin and exposed pad must be connected to the same ground plane.
3, 7, 27, 31	VREF-AC0 VREF-AC1 VREF-AC2 VREF-AC3	Reference Voltage: This reference output is equivalent to $V_{CC}-1.4\text{V}$ . It is used for AC-coupled inputs. When interfacing to AC input signals, connect $V_{REF-AC}$ directly to the $V_T$ pin and bypass with 0.01μF low ESR capacitor to $V_{CC}$ . See “Input Interface Applications” section. Maximum sink/source current is 0.5mA.

**TRUTH TABLE**

SEL1	SEL0	
0	0	IN0 Input Selected
0	1	IN1 Input Selected
1	0	IN2 Input Selected
1	1	IN3 Input Selected

### Absolute Maximum Ratings<sup>(1)</sup>

Power Supply Voltage ( $V_{CC}$ ) ..... -0.5V to +4.0V  
 Input Voltage ( $V_{IN}$ ) ..... -0.5V to  $V_{CC}$   
 CML Output Voltage ( $V_{OUT}$ ) .....  $V_{CC}-1.0V$  to  $V_{CC}+0.5V$   
 Termination Current<sup>(3)</sup>  
     Source or sink current on  $V_T$  pin .....  $\pm 100mA$   
 Input Current  
     Source or sink current on IN, /IN pin .....  $\pm 50mA$   
 Lead Temperature (soldering, 20 sec.) ..... 260°C  
 Storage Temperature Range ( $T_S$ ) ..... -65°C to +150°C

### Operating Ratings<sup>(2)</sup>

Power Supply Voltage ( $V_{CC}$ ) ..... +2.375V to +2.625V  
     ..... +3.0V to +3.6V  
 Ambient Temperature Range ( $T_A$ ) ..... -40°C to +85°C  
 Package Thermal Resistance<sup>(4)</sup>  
     MLF® ( $\theta_{JA}$ )  
         Still-Air ..... 35°C/W  
     MLF® ( $\psi_{JB}$ )  
         Junction-to-Board ..... 2°C/W

## DC ELECTRICAL CHARACTERISTICS<sup>(5)</sup>

$T_A = -40^\circ C$  to  $85^\circ C$ , unless otherwise stated.

Symbol	Parameter	Condition	Min	Typ	Max	Units
$V_{CC}$	Power Supply Voltage	$V_{CC} = 2.5V$	2.375	2.5	2.625	V
		$V_{CC} = 3.3V$	3.0	3.3	3.6	V
$I_{CC}$	Power Supply Current	No load, max. $V_{CC}$		120	150	mA
$R_{DIFF\_IN}$	Differential Input Resistance (IN-to-/IN)		80	100	120	$\Omega$
$R_{IN}$	Input Resistance (IN-to- $V_T$ , /IN-to- $V_T$ )		40	50	60	$\Omega$
$V_{IH}$	Input HIGH Voltage (IN-to-/IN)	<b>Note 6</b>	$V_{CC}-1.6$		$V_{CC}$	V
$V_{IL}$	Input LOW Voltage (IN-to-/IN)		0		$V_{IH}-0.1$	V
$V_{IN}$	Input Voltage Swing (IN-to-/IN)	See Figure 1a.	0.1		1.7	V
$V_{DIFF\_IN}$	Differential Input Voltage Swing (IN-to-/IN)	See Figure 1b.	0.2			V
$V_{T\ IN}$	Max Input Voltage (IN-to- $V_T$ )				1.28	V
$V_{REF\_AC}$	Reference Voltage		$V_{CC}-1.3$	$V_{CC}-1.2$	$V_{CC}-1.1$	V

**Notes:**

1. Permanent device damage may occur if ratings in the "Absolute Maximum Ratings" section are exceeded. This is a stress rating only and functional operation is not implied at conditions other than those detailed in the operational sections of this data sheet. Exposure to absolute maximum ratings conditions for extended periods may affect device reliability.
2. The data sheet limits are not guaranteed if the device is operated beyond the operating ratings.
3. Due to the limited drive capability, use for input of the same package only.
4. Thermal performance assumes exposed pad is soldered (or equivalent) to the device's most negative potential (GND) on the PCB.  $\psi_{JB}$  uses 4-layer  $\theta_{JA}$  in still air number unless otherwise stated.
5. The circuit is designed to meet the DC specifications shown in the above table after thermal equilibrium has been established.
6.  $V_{IH}$  (min) not lower than 1.2V.

**CML OUTPUT DC ELECTRICAL CHARACTERISTICS<sup>(7)</sup>**

$V_{CC} = 2.5V \pm 5\%$  or  $3.3V \pm 10\%$ ;  $T_A = -40^\circ C$  to  $85^\circ C$ ;  $R_L = 100\Omega$  across each output pair or equivalent; unless otherwise stated.

Symbol	Parameter	Condition	Min	Typ	Max	Units
$V_{OH}$	Output HIGH Voltage		$V_{CC}-0.020$		$V_{CC}$	V
$V_{OUT}$	Output Voltage Swing	See Figure 1a.	325	400		mV
$V_{DIFF\_OUT}$	Differential Output Voltage Swing	See Figure 1b.	650	800		mV
$R_{OUT}$	Output Source Impedance		40	50	60	$\Omega$

**LVTTTL/CMOS DC ELECTRICAL CHARACTERISTICS<sup>(7)</sup>**

$V_{CC} = 2.5V \pm 5\%$  or  $3.3V \pm 10\%$ ;  $T_A = -40^\circ C$  to  $+85^\circ C$ , unless otherwise stated.

Symbol	Parameter	Condition	Min	Typ	Max	Units
$V_{IH}$	Input HIGH Voltage	SEL0, SEL1	2.0			V
$V_{IL}$	Input LOW Voltage	SEL0, SEL1			0.8	V
$I_{IH}$	Input HIGH Current				40	$\mu A$
$I_{IL}$	Input LOW Current				-300	$\mu A$

**Note:**

7. The circuit is designed to meet the DC specifications shown in the above table after thermal equilibrium has been established.

**AC ELECTRICAL CHARACTERISTICS<sup>(8)</sup>**

$V_{CC} = 2.5V \pm 5\%$  or  $3.3V \pm 10\%$ ;  $R_L = 100\Omega$  across each output pair, or equivalent;  $T_A = -40^\circ C$  to  $+85^\circ C$ ,  $V_{IN} \geq 100mV$  unless otherwise stated.

Symbol	Parameter	Condition	Min	Typ	Max	Units
$f_{MAX}$	Maximum Operating Frequency	NRZ Data	10.7			Gbps
		$V_{OUT} \geq 200mV$ Clock		7		GHz
$t_{pd}$	Propagation Delay (Diff) (IN to Q) (SEL to Q)	$V_{IN} \geq 100mV$	170	260	340	ps
			100		500	ps
$t_{pd} Tempco$	Differential Propagation Delay Temperature Coefficient			115		fs/°C
$t_{SKEW}$	Output-to-Output	<b>Note 9</b>		7	20	ps
	Part-to-Part	<b>Note 10</b>			50	ps
$t_{JITTER}$	Data Random Jitter	<b>Note 11</b> 2.5Gbps to 3.2Gbps			1	ps <sub>RMS</sub>
	Deterministic Jitter	<b>Note 12</b> 2.5Gbps to 3.2Gbps			10	ps <sub>PP</sub>
	Clock Cycle-to-Cycle Jitter	<b>Note 13</b>			1	ps <sub>RMS</sub>
	Total Jitter	<b>Note 14</b>			10	ps <sub>PP</sub>
	Crosstalk Induced Jitter (Adjacent Channel)	<b>Note 15</b>			0.7	ps <sub>RMS</sub>
$t_r, t_f$	Output Rise/Fall Time	20% to 80%, Full output swing	20	45	60	ps

**Notes:**

- 8. High frequency AC electricals are guaranteed by design and characterization.
- 9. Output-to-output skew is measured between outputs under identical input conditions.
- 10. Part-to-part skew is defined for two parts with identical power supply voltages at the same temperature and with no skew of the edges at the respective inputs.
- 11. Random jitter is measured with a K28.7 comma detect character pattern, measured at 2.5Gbps to 3.2Gbps.
- 12. Deterministic jitter is measured at 2.5Gbps to 3.2Gbps, with both K28.5 and 2<sup>23</sup>-1 PRBS pattern.
- 13. Cycle-to-cycle jitter definition: the variation of periods between adjacent cycles,  $T_n - T_{n-1}$  where T is the time between rising edges of the output signal.
- 14. Total jitter definition: with an ideal clock input of frequency  $\leq f_{MAX}$ , no more than one output edge in 10<sup>12</sup> output edges will deviate by more than the specified peak-to-peak jitter value.
- 15. Crosstalk is measured at the output while applying two similar clock frequencies that are asynchronous with respect to each other at the inputs.

**SINGLE-ENDED AND DIFFERENTIAL SWINGS**

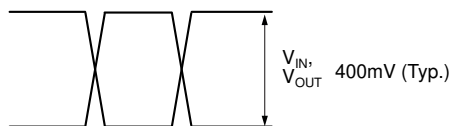


Figure 1a. Single-Ended Voltage Swing

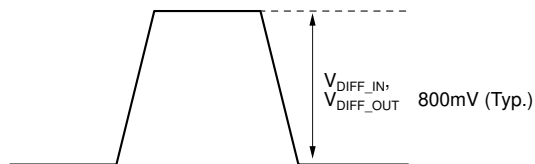
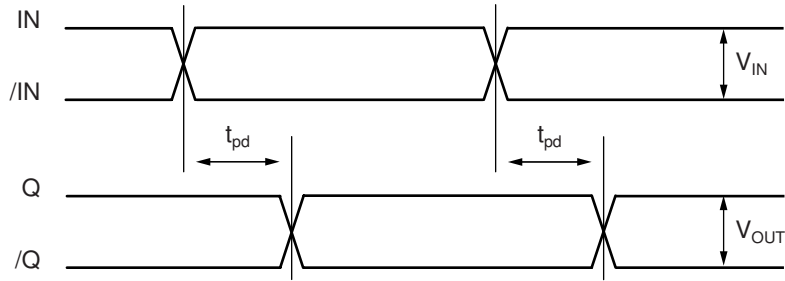
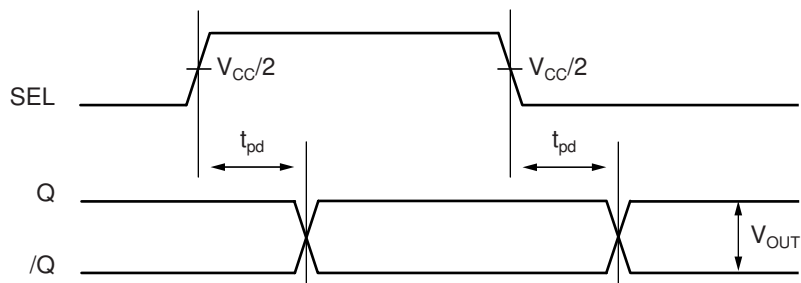


Figure 1b. Differential Voltage Swing

**TIMING DIAGRAMS**



**Figure 2a. IN-to-Q Timing Diagram**

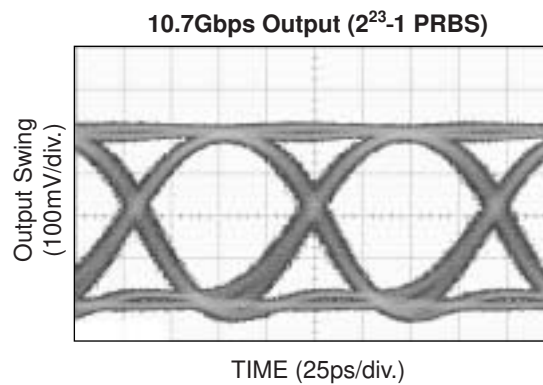
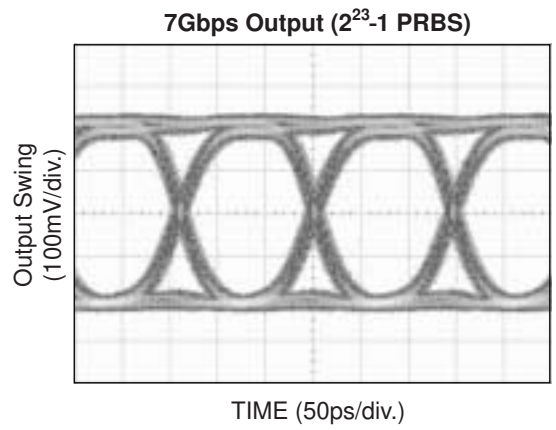
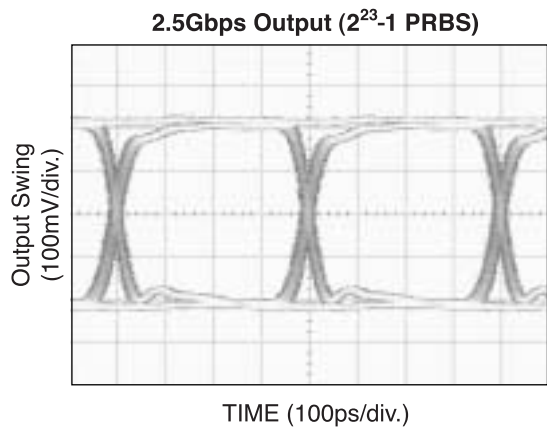
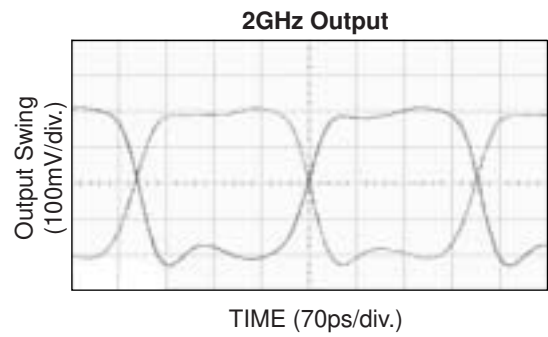
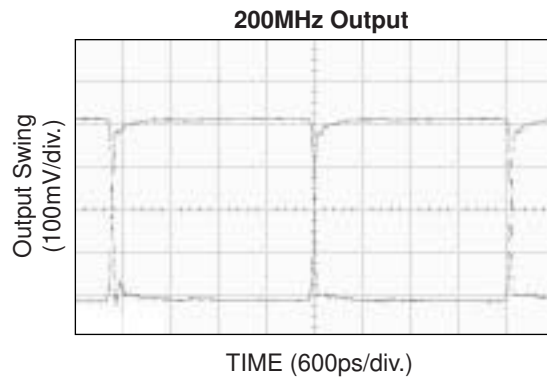


**Figure 2b. SEL-to-Q Timing Diagram**

- SEL0 Q:            SEL1 = LOW;    IN0, /IN1 = LOW;    /IN0, IN1 = HIGH
- or:    SEL1 = HIGH;    IN2, /IN3 = LOW;    /IN2, IN3 = HIGH
  
- SEL1 Q:            SEL0 = LOW;    IN0, /IN2 = LOW;    /IN0, IN2 = HIGH
- or:    SEL0 = HIGH;    IN1, /IN3 = LOW;    /IN1, IN3 = HIGH

# FUNCTIONAL CHARACTERISTICS

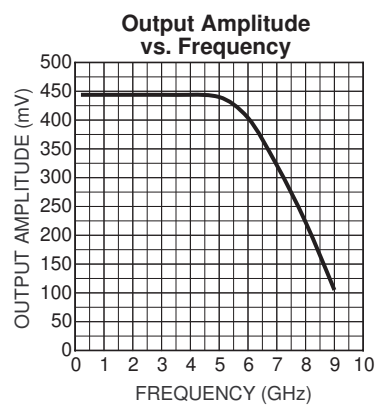
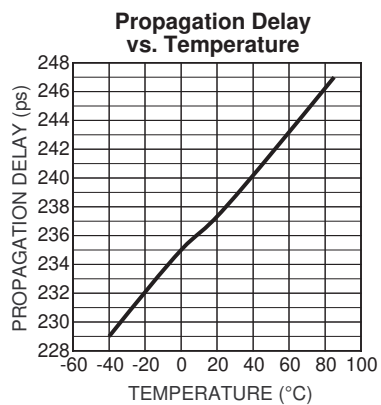
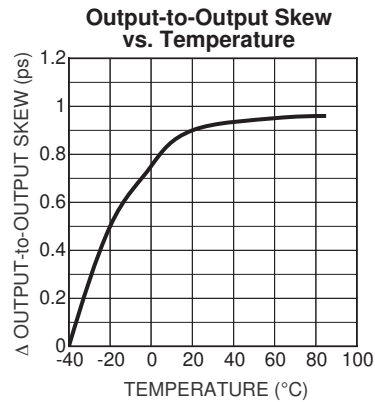
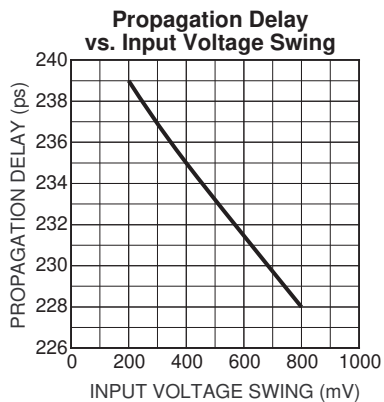
$V_{CC} = 2.5V$ ,  $GND = 0$ ,  $V_{IN} = 100mV$ ,  $T_A = 25^\circ C$ , unless otherwise stated.



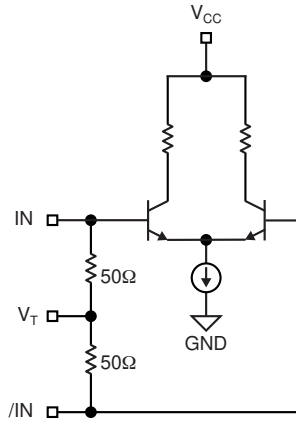


**TYPICAL OPERATING CHARACTERISTICS**

$V_{CC} = 2.5V$ ,  $GND = 0$ ,  $V_{IN} = 100mV$ ,  $T_A = 25^{\circ}C$ , unless otherwise stated.

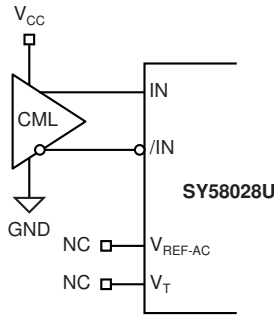


**INPUT STAGE**

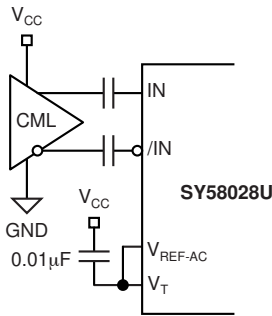


**Figure 3. Simplified Differential Input Stage**

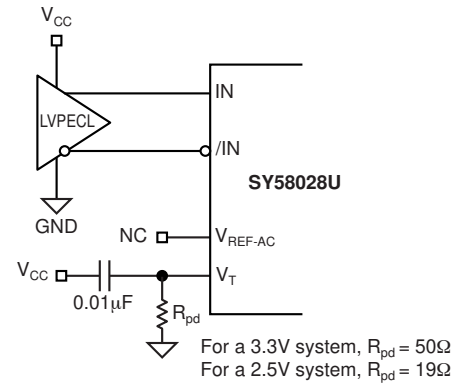
**INPUT INTERFACE APPLICATIONS**



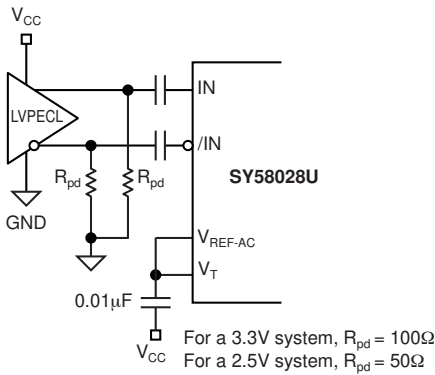
**Figure 4a. DC-Coupled CML Interface**  
*Option: May connect V<sub>T</sub> to V<sub>CC</sub>*



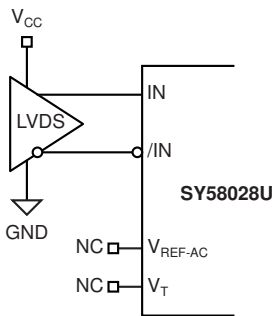
**Figure 4b. CML Interface (AC-Coupled)**



**Figure 4c. DC-Coupled PECL Interface**

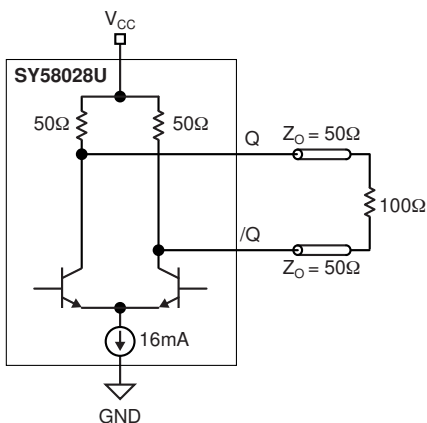


**Figure 4d. AC-Coupled LVPECL Interface**

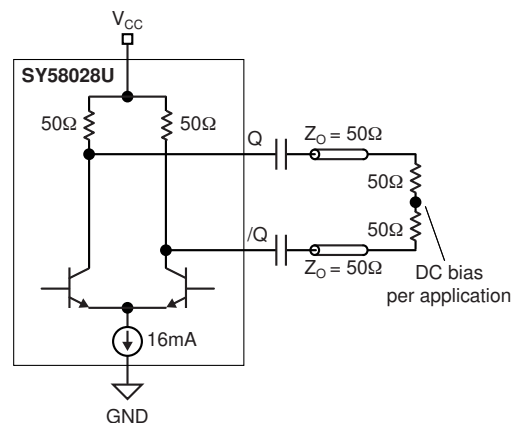


**Figure 4f. LVDS Interface**

**OUTPUT INTERFACE APPLICATIONS**



**Figure 5a. CML DC-Coupled (100Ω Termination)**

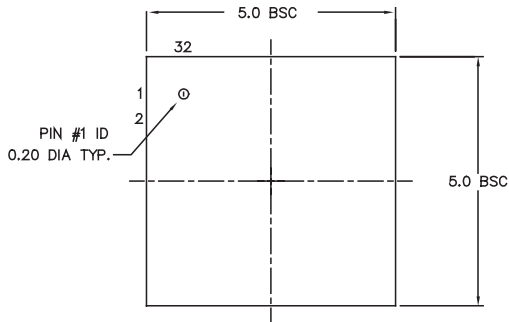


**Figure 5b. CML AC-Coupled (50Ω Termination)**

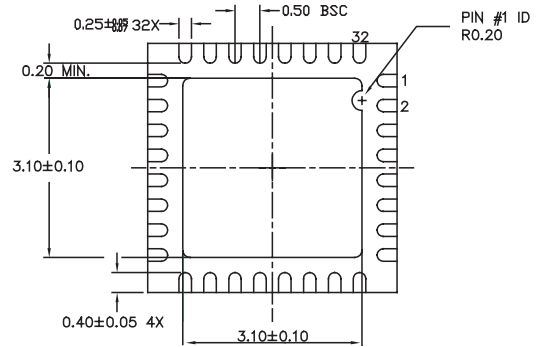
**RELATED MICREL PRODUCTS AND SUPPORT DOCUMENTATION**

Part Number	Function	Data Sheet Link
SY58028U	Ultra Precision Differential CML 4:1 MUX with 1:2 Fanout and Internal I/O Termination	<a href="http://www.micrel.com/product-info/products/sy58028u.shtml">http://www.micrel.com/product-info/products/sy58028u.shtml</a>
SY58029U	Ultra Precision Differential LVPECL 4:1 MUX with 1:2 Fanout and Internal Termination	<a href="http://www.micrel.com/product-info/products/sy58029u.shtml">http://www.micrel.com/product-info/products/sy58029u.shtml</a>
SY58030U	Ultra Precision, 400mV Differential LVPECL 4:1 MUX with 1:2 Fanout and Internal Termination	<a href="http://www.micrel.com/product-info/products/sy58030u.shtml">http://www.micrel.com/product-info/products/sy58030u.shtml</a>
	MLF® Application Note	<a href="http://www.amkor.com/products/notes_papers/MLF_AppNote_0902.pdf">www.amkor.com/products/notes_papers/MLF_AppNote_0902.pdf</a>
HBW Solutions	New Products and Applications	<a href="http://www.micrel.com/product-info/products/solutions.shtml">www.micrel.com/product-info/products/solutions.shtml</a>

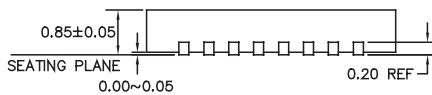
**32-PIN MicroLeadFrame® (MLF-32)**



TOP VIEW



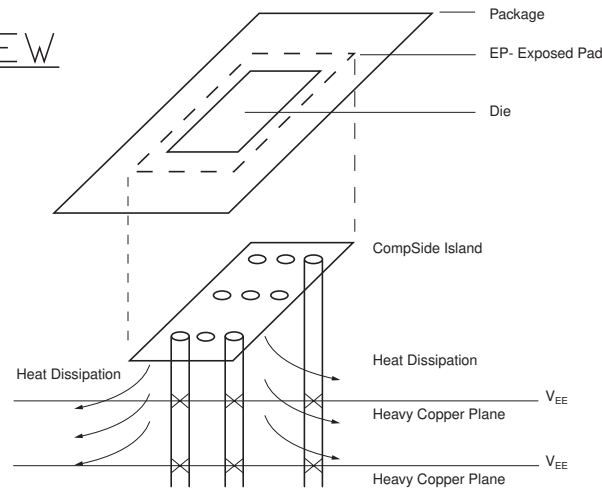
BOTTOM VIEW



SIDE VIEW

NOTE:

1. ALL DIMENSIONS ARE IN MILLIMETERS.
2. MAX. PACKAGE WARPAGE IS 0.05 mm.
3. MAXIMUM ALLOWABLE BURRS IS 0.076 mm IN ALL DIRECTIONS.
4. PIN #1 ID ON TOP WILL BE LASER/INK MARKED.



**PCB Thermal Consideration for 32-Pin MLF® Package  
(Always solder, or equivalent, the exposed pad to the PCB)**

**Package Notes:**

1. Package meets Level 2 qualification.
2. All parts dry-packaged before shipment.
3. Exposed pads must be soldered to a ground for proper thermal management.

**MICREL, INC. 2180 FORTUNE DRIVE SAN JOSE, CA 95131 USA**

TEL + 1 (408) 944-0800 FAX + 1 (408) 474-100 WEB <http://www.micrel.com>

The information furnished by Micrel in this data sheet is believed to be accurate and reliable. However, no responsibility is assumed by Micrel for its use. Micrel reserves the right to change circuitry and specifications at any time without notification to the customer.

Micrel Products are not designed or authorized for use as components in life support appliances, devices or systems where malfunction of a product can reasonably be expected to result in personal injury. Life support devices or systems are devices or systems that (a) are intended for surgical implant into the body or (b) support or sustain life, and whose failure to perform can be reasonably expected to result in a significant injury to the user. A Purchaser's use or sale of Micrel Products for use in life support appliances, devices or systems is at Purchaser's own risk and Purchaser agrees to fully indemnify Micrel for any damages resulting from such use or sale.

© 2005 Micrel, Incorporated.