



Chipsmall Limited consists of a professional team with an average of over 10 year of expertise in the distribution of electronic components. Based in Hongkong, we have already established firm and mutual-benefit business relationships with customers from,Europe,America and south Asia,supplying obsolete and hard-to-find components to meet their specific needs.

With the principle of "Quality Parts,Customers Priority,Honest Operation,and Considerate Service",our business mainly focus on the distribution of electronic components. Line cards we deal with include Microchip,ALPS,ROHM,Xilinx,Pulse,ON,Everlight and Freescale. Main products comprise IC,Modules,Potentiometer,IC Socket,Relay,Connector.Our parts cover such applications as commercial,industrial, and automotives areas.

We are looking forward to setting up business relationship with you and hope to provide you with the best service and solution. Let us make a better world for our industry!



Contact us

Tel: +86-755-8981 8866 Fax: +86-755-8427 6832

Email & Skype: info@chipsmall.com Web: www.chipsmall.com

Address: A1208, Overseas Decoration Building, #122 Zhenhua RD., Futian, Shenzhen, China





SY58051AU

Ultra-Precision CML AnyGate[®]
with Internal Input and Output Termination

Revision 1.0

General Description

The SY58051AU is an ultra-fast, low jitter universal logic gate with a guaranteed maximum data or clock throughput of 10.7Gbps or 8GHz, respectively. This AnyGate[®] differential logic device will produce many logic functions of two Boolean variables, such as AND, NAND, OR, NOR, DELAY, or NEGATION.

The SY58051AU differential inputs include a unique internal termination design that allows access to the termination network throughout a VT pin. This feature allows the device to easily interface to different logic standards, both AC- and DC-coupled, without external resistor-bias and termination networks. The result is a clean, stub-free, low-jitter interface solution. The differential CML output is optimized for environments with internal 50Ω source termination and a 400mV output swing.

The SY58051AU operates from a 2.5V or 3.3V supply and is guaranteed over the full industrial temperature range of -40°C to +85°C. The SY58051AU is part of Micrel's Precision Edge[®] product family.

Datasheets and support documentation are available on Micrel's web site at: www.micrel.com.

Functional Block Diagram

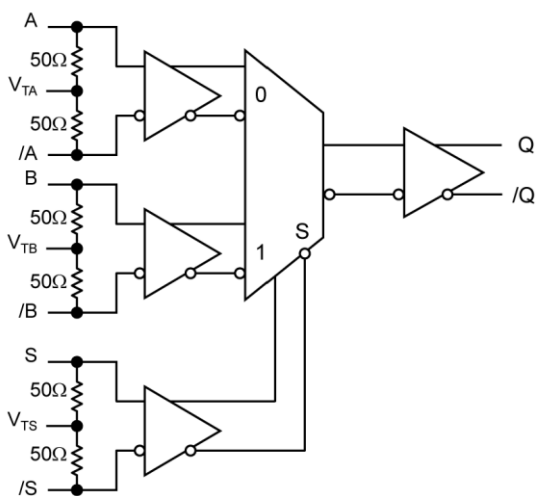

Precision Edge[®]

Features

- Three matched-delay input pairs provide any logic function: AND, NAND, OR, NOR
- Guaranteed AC performance over temperature and voltage:
 - DC to >10.7Gbps data rate throughput
 - DC to >8GHz clock f_{MAX}
 - <160ps Any In-to-Out t_{pd}
 - 20ps typical t_r/t_f
- Ultra-low jitter design:
 - 0.2ps_{RMS} typical random jitter (data)
 - 2ps_{PP} typical deterministic jitter (data)
 - 5ps_{PP} typical total jitter (clock)
 - 46fs_{RMS} typical additive phase jitter (clock)
- Unique input termination and VT pin accepts AC- and DC-coupled inputs (CML, PECL)
- Internal 50Ω output source termination
- Typical 400mV CML output swing ($R_L = 50\Omega$)
- Internal 50Ω input termination
- Power supply 2.5V ±5% or 3.3V ±10%
- -40°C to +85°C industrial temperature range
- Available in a 16-pin 3mm × 3mm QFN package

Applications

- Data communication systems
- OC-192, OC-192+FEC data-to-clock
- All SONETOC-3 – OC-768 applications
- Fibre Channel
- Gigabit Ethernet
- ATE
- Test and measurement

AnyGate and Precision Edge are registered trademarks of Micrel, Inc.

Micrel Inc. • 2180 Fortune Drive • San Jose, CA 95131 • USA • tel +1 (408) 944-0800 • fax + 1 (408) 474-1000 • <http://www.micrel.com>

Ordering Information

Part Number	Package Type	Temperature Range	Package Marking	Lead Finish
SY58051AUMG ⁽¹⁾	Pb-Free QFN-16	Industrial	051A with Pb-Free bar-line indicator	NiPdAu Pb-Free
SY58051AUMG TR ^(1,2)	Pb-Free QFN-16	Industrial	051A with Pb-Free bar-line indicator	NiPdAu Pb-Free

Notes:

1. Pb-Free package recommended for new designs.
2. Tape and Reel

Pin Configuration

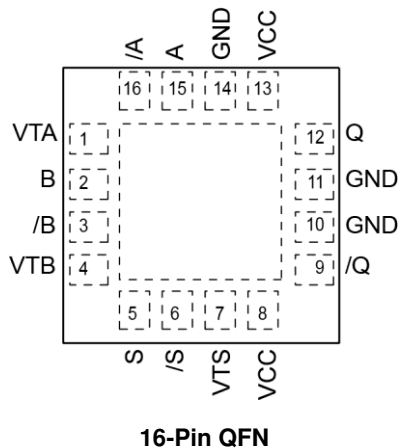

Pin Description

Pin Number	Pin Name	Pin Function
1	VTA	Input termination center tap: Each of the two inputs (A, /A) terminates to this pin through a 50Ω resistor. The VTA pin provides a center-tap to a termination network for maximum interface flexibility. See the Input Interface Applications section for more details.
15, 16 2, 3	A, /A B, /B	Differential input: These input pairs are the two data inputs to the device. Each pin of a pair (A, /A) and (B, /B) internally terminates to the VTA or VTB pin to 50Ω. Note that these inputs will default to an indeterminate state if left open. See the Input Interface Applications section for more details.
4	VTB	Input termination center tap: Each of the two inputs (B, /B) terminates to this pin through a 50Ω resistor. The VTB pin provides a center-tap to a termination network for maximum interface flexibility. See the Input Interface Applications section for more details.
5, 6	S, /S	Differential input: This input pair is the select input to the device. Each pin of this pair internally terminates to the VTS pin to 50Ω. Note that this input will default to an indeterminate state if left open. See the Input Interface Applications section for more details.
7	VTS	Input termination center tap: Each of the two inputs (S, /S) terminates to this pin. The VTS pin provides a center-tap to a termination network for maximum interface flexibility.
8, 13	VCC	Positive power supply. Bypass with 0.1μF 0.01μF low ESR capacitors.
12, 9	Q, /Q	Differential output: This CML output pair is the output of the device. It is a logic function of the A, B, and S inputs. See the Truth Tables for details.
10, 11, 14	GND	Ground. Exposed pad must be connected to the same potential as GND pin.

Truth Tables

A	/A	B	/B	S	/S	Q	/Q
0	1	X	X	0	1	0	1
1	0	X	X	0	1	1	0
X	X	0	1	1	0	0	1
X	X	1	0	1	0	1	0

	<p>AND/NAND</p> <table border="1"> <thead> <tr> <th>A</th> <th>α B</th> <th>β S</th> <th>$\alpha \cdot \beta$ Q</th> <th>$\overline{(\alpha \cdot \beta)}$ /Q</th> </tr> </thead> <tbody> <tr> <td>L</td> <td>L</td> <td>L</td> <td>L</td> <td>H</td> </tr> <tr> <td>L</td> <td>H</td> <td>L</td> <td>L</td> <td>H</td> </tr> <tr> <td>L</td> <td>L</td> <td>H</td> <td>L</td> <td>H</td> </tr> <tr> <td>L</td> <td>H</td> <td>H</td> <td>H</td> <td>L</td> </tr> </tbody> </table>	A	α B	β S	$\alpha \cdot \beta$ Q	$\overline{(\alpha \cdot \beta)}$ /Q	L	L	L	L	H	L	H	L	L	H	L	L	H	L	H	L	H	H	H	L
A	α B	β S	$\alpha \cdot \beta$ Q	$\overline{(\alpha \cdot \beta)}$ /Q																						
L	L	L	L	H																						
L	H	L	L	H																						
L	L	H	L	H																						
L	H	H	H	L																						
	<p>OR/NOR</p> <table border="1"> <thead> <tr> <th>α A</th> <th>B</th> <th>β S</th> <th>$\alpha + \beta$ Q</th> <th>$\overline{(\alpha + \beta)}$ /Q</th> </tr> </thead> <tbody> <tr> <td>L</td> <td>H</td> <td>L</td> <td>L</td> <td>H</td> </tr> <tr> <td>H</td> <td>H</td> <td>L</td> <td>H</td> <td>L</td> </tr> <tr> <td>L</td> <td>H</td> <td>H</td> <td>H</td> <td>L</td> </tr> <tr> <td>H</td> <td>H</td> <td>H</td> <td>H</td> <td>L</td> </tr> </tbody> </table>	α A	B	β S	$\alpha + \beta$ Q	$\overline{(\alpha + \beta)}$ /Q	L	H	L	L	H	H	H	L	H	L	L	H	H	H	L	H	H	H	H	L
α A	B	β S	$\alpha + \beta$ Q	$\overline{(\alpha + \beta)}$ /Q																						
L	H	L	L	H																						
H	H	L	H	L																						
L	H	H	H	L																						
H	H	H	H	L																						
	<p>DELAY/NEGATION</p> <table border="1"> <thead> <tr> <th>α A</th> <th>B</th> <th>S</th> <th>α Q</th> <th>$\bar{\alpha}$ /Q</th> </tr> </thead> <tbody> <tr> <td>L</td> <td></td> <td>L</td> <td>L</td> <td>H</td> </tr> <tr> <td>H</td> <td></td> <td>L</td> <td>H</td> <td>L</td> </tr> </tbody> </table>	α A	B	S	α Q	$\bar{\alpha}$ /Q	L		L	L	H	H		L	H	L										
α A	B	S	α Q	$\bar{\alpha}$ /Q																						
L		L	L	H																						
H		L	H	L																						
	<p>DELAY/NEGATION</p> <table border="1"> <thead> <tr> <th>A</th> <th>β B</th> <th>S</th> <th>β Q</th> <th>$\bar{\beta}$ /Q</th> </tr> </thead> <tbody> <tr> <td></td> <td>L</td> <td>H</td> <td>L</td> <td>H</td> </tr> <tr> <td></td> <td>H</td> <td>H</td> <td>H</td> <td>L</td> </tr> </tbody> </table>	A	β B	S	β Q	$\bar{\beta}$ /Q		L	H	L	H		H	H	H	L										
A	β B	S	β Q	$\bar{\beta}$ /Q																						
	L	H	L	H																						
	H	H	H	L																						
	<p>2:1 MUX</p> <table border="1"> <thead> <tr> <th>S</th> <th>Q</th> <th>/Q</th> </tr> </thead> <tbody> <tr> <td>L</td> <td>A</td> <td>\bar{A}</td> </tr> <tr> <td>H</td> <td>B</td> <td>\bar{B}</td> </tr> </tbody> </table>	S	Q	/Q	L	A	\bar{A}	H	B	\bar{B}																
S	Q	/Q																								
L	A	\bar{A}																								
H	B	\bar{B}																								

Absolute Maximum Ratings⁽³⁾

Supply Voltage (V_{CC})	–0.5V to +4.0V
Input Voltage (V_{IN})	–0.5V to V_{CC}
CML Output Voltage (V_{OUT})	$V_{CC} - 1.0V$ to $V_{CC} + 0.5V$
Termination Current ⁽⁵⁾	
Source or Sink Current on V_{TA} , V_{TB} , V_{TS}	±60mA
Input Current	
Source or Sink Current on A, /A, B, /B, S, /S	±30mA
Lead Temperature (soldering, 20s)	260°C
Storage Temperature (T_s)	–65°C to +150°C

Operating Ratings⁽⁴⁾

Supply Voltage (V_{CC})	+2.375V to +2.625V or +2.97V to +3.63V
Ambient Temperature (T_A)	–40°C to +85°C
Junction Thermal Resistance ⁽⁶⁾	
QFN (θ_{JA}) Still-Air	61°C/W
QFN (ψ_{JB})	38°C/W

DC Electrical Characteristics^(7, 8)

$T_A = -40^\circ\text{C}$ to $+85^\circ\text{C}$.

Symbol	Parameter	Condition	Min.	Typ.	Max.	Units
V_{CC}	Power supply		2.375 2.97	2.5 3.3	2.625 3.63	V
I_{CC}	Power supply current	With load for either 2.5V or 3.3V supply		42	60	mA
R_{DIFF_IN}	Differential input resistance (A-to-/A), (B-to-/B), or (S-to-/S)		90	100	110	Ω
R_{IN}	Input resistance (A-to- V_{TA} , B-to- V_{TB} , or S-to- V_{TS})		45	50	55	Ω
V_{IH}	Input HIGH voltage (A, /A), (B, /B), or (S, /S)	Note 9	1.2		V_{CC}	V
V_{IL}	Input LOW voltage (A, /A), (B, /B), or (S, /S)	Note 9	0		$V_{IH} + 0.1$	mV
V_{IN}	Input voltage swing (A, /A), (B, /B), or (S, /S)	Note 9 See Figure 3	100			mV
V_{DIFF_IN}	Differential input voltage swing (A, /A), (B, /B), or (S, /S)	Note 9 See Figure 4	200			mV
I_{IN}	Input current (A, /A), (B, /B), or (S, /S)	Note 9			21	mA

Notes:

- Exceeding the absolute maximum ratings may damage the device.
- The device is not guaranteed to function outside its operating ratings.
- Due to the limited drive capability use for input of the same package only.
- Package thermal resistance assumes exposed pad is soldered (or equivalent) to the devices most negative potential on the PCB. ψ_{JB} uses 4-layer θ_{JA} in still-air, unless otherwise stated.
- Specification for packaged product only.
- The circuit is designed to meet the DC specifications shown in the table above after thermal equilibrium has been established.
- Due to the internal termination (see "Input Structures" section), the input current depends upon the applied voltages at A, /A, and V_{TA} inputs, the B, /B, and V_{TB} inputs, or the S, /S, and V_{TS} inputs. Do not apply a combination of voltages that causes the input current to exceed the maximum limit.

CML Electrical Characteristics⁽¹⁰⁾

$V_{CC} = 2.5V \pm 5\%$ or $3.3V \pm 10\%$; $R_L = 100\Omega$ across output pair or equivalent; $T_A = -40^\circ C$ to $+85^\circ C$.

Symbol	Parameter	Condition	Min.	Typ.	Max.	Units
V_{OH}	Output HIGH voltage (Q, /Q)	$R_L = 50\Omega$ to V_{CC}	$V_{CC} - 0.020$		V_{CC}	V
V_{OUT}	Output voltage swing (Q, /Q)	See Figure 3	325	400		mV
V_{DIFF_OUT}	Differential output voltage swing (Q, /Q)	See Figure 4	650	800		mV
R_{OUT}	Output source impedance (Q, /Q)		45	50	55	Ω

AC Electrical Characteristics^(10, 11)

$V_{CC} = 2.5V \pm 5\%$ or $3.3V \pm 10\%$; $R_L = 100\Omega$ across output pair or equivalent; $T_A = -40^\circ C$ to $+85^\circ C$.

Symbol	Parameter	Condition	Min.	Typ.	Max.	Units
f_{MAX}	Maximum operating frequency	Clock NRZ data	8 10.7			GHz Gbps
t_{pd}	Propagation delay any input (A, B, S)-to-Q		70		160	ps
t_{SKEW}	Part-to-part skew	Note 12			100	ps
t_{JITTER}	Data					
	Random jitter (RJ)	Note 13		0.2	1	ps _{RMS}
	Deterministic jitter (DJ)	Note 14		2	5	ps _P
	Clock					
	Cycle-to-cycle jitter (RJ)	Note 15		0.5	1	ps _{RMS}
	Total jitter (TJ)	Note 16			5	10
	Additive phase jitter	622MHz input integrated over 12kHz – 20MHz		46		fs _{RMS}
t_r/t_f	Output rise/fall times (20% to 80%)	At full output swing		20	50	ps

Notes:

- Specification for packaged product only.
- Measured with 100mV input swing. See the Timing Diagrams section for definition of parameters. High-frequency AC parameters are guaranteed by design and characterization.
- Skew is defined for two parts with identical power supply voltages at the same temperature and with no skew of the edges at the respective inputs.
- Random jitter is measured with a K28.7 comma detect character pattern, measured at 2.5Gbps/3.2Gbps.
- Deterministic jitter is measured at 2.5Gbps/3.2Gbps with both K28.5 and $2^{23}-1$ PRBS pattern.
- Cycle-to-cycle jitter definition: the variation of periods between adjacent cycles, $T_n - T_{n-1}$ where T_n is the time between rising edges of the output signal.
- Total jitter definition: with an ideal clock input of frequency $\leq f_{MAX}$, no more than one output edge in 10^{12} output edges will deviate by more than the specified peak-to-peak jitter value.

Timing Diagram

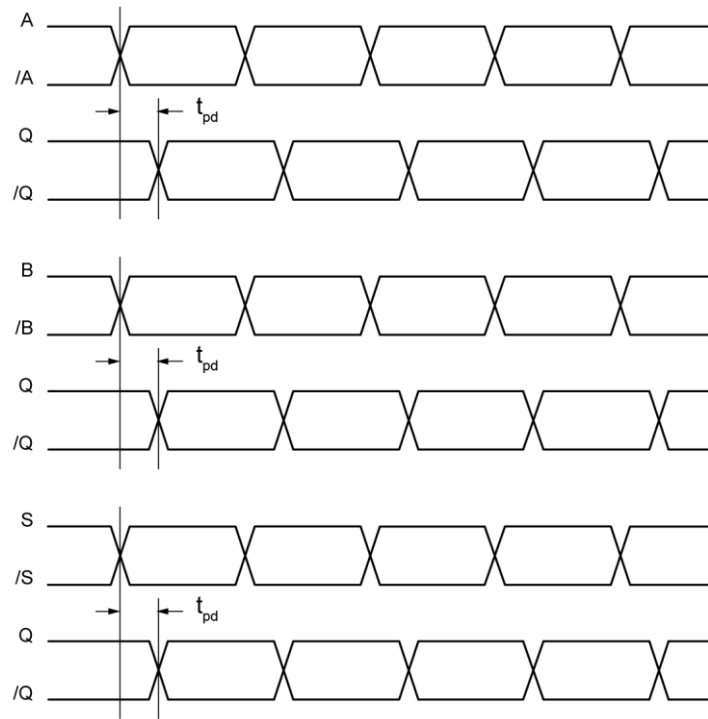

Input and Output Stage Internal Termination

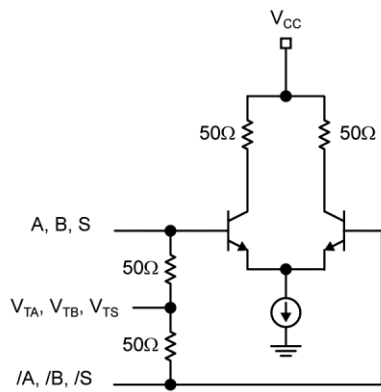

Figure 1. Simplified Differential Input Stage

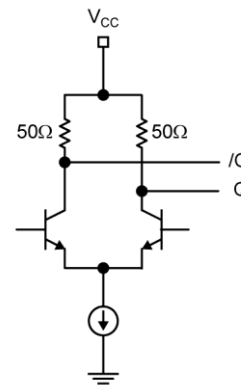

Figure 2. Simplified Differential Output Stage

Definition of Single-Ended and Differential Swings

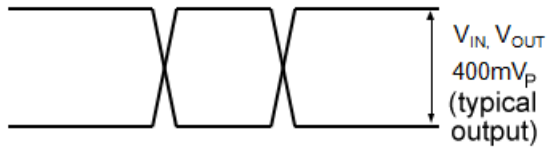

Figure 3. Single-Ended Swing

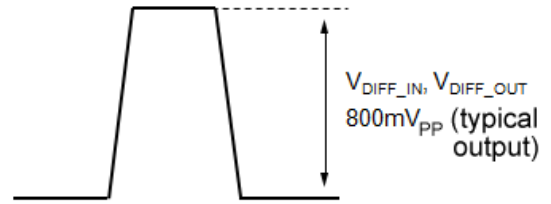
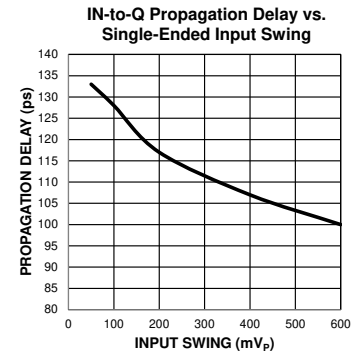
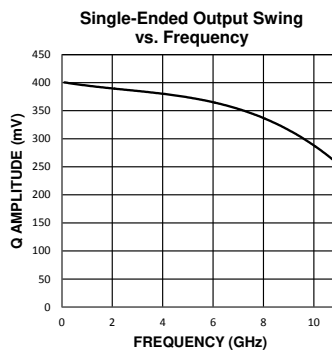
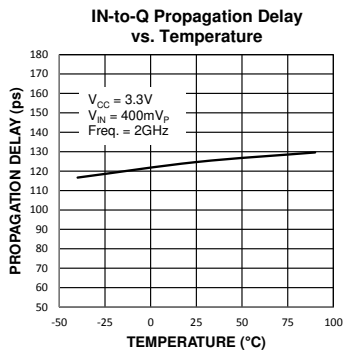

Figure 4. Differential Swing

Typical Operating Characteristics



Functional Characteristics

$V_{IN} = 400mV$, 3.3V supply.

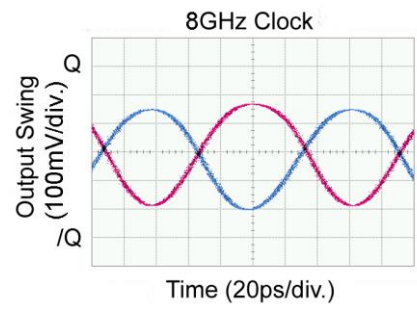
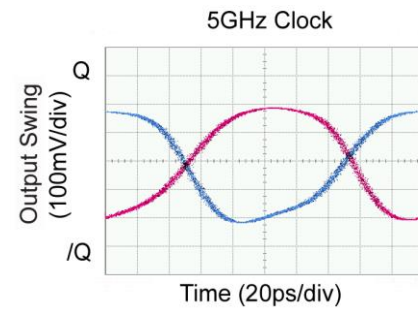
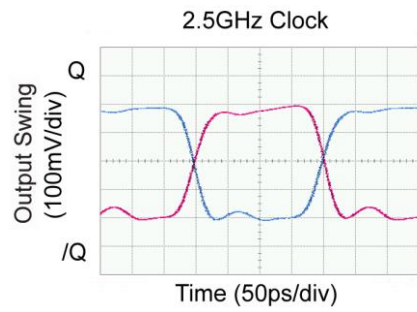
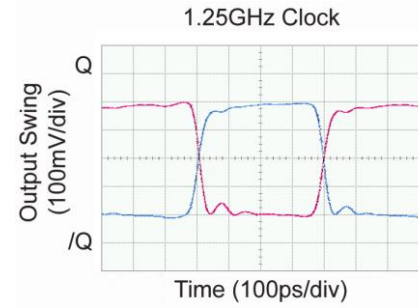
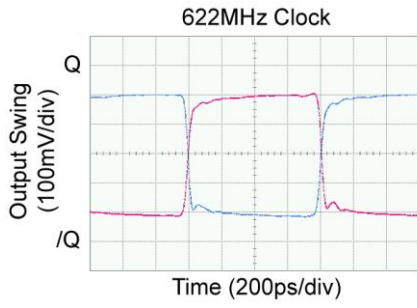

Functional Characteristics (Continued)

$V_{IN} = 400\text{mV}$, 3.3V supply.

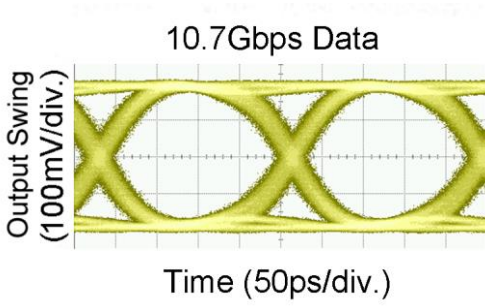
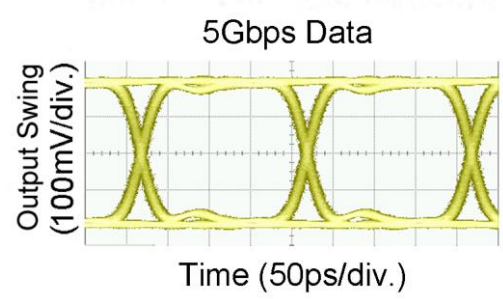
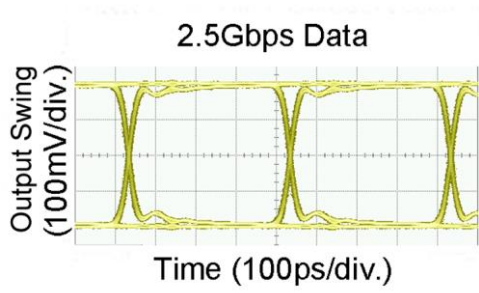

Phase Noise Plot

V_{CC} = 3.0V, CML Input, Temperature = 25°C

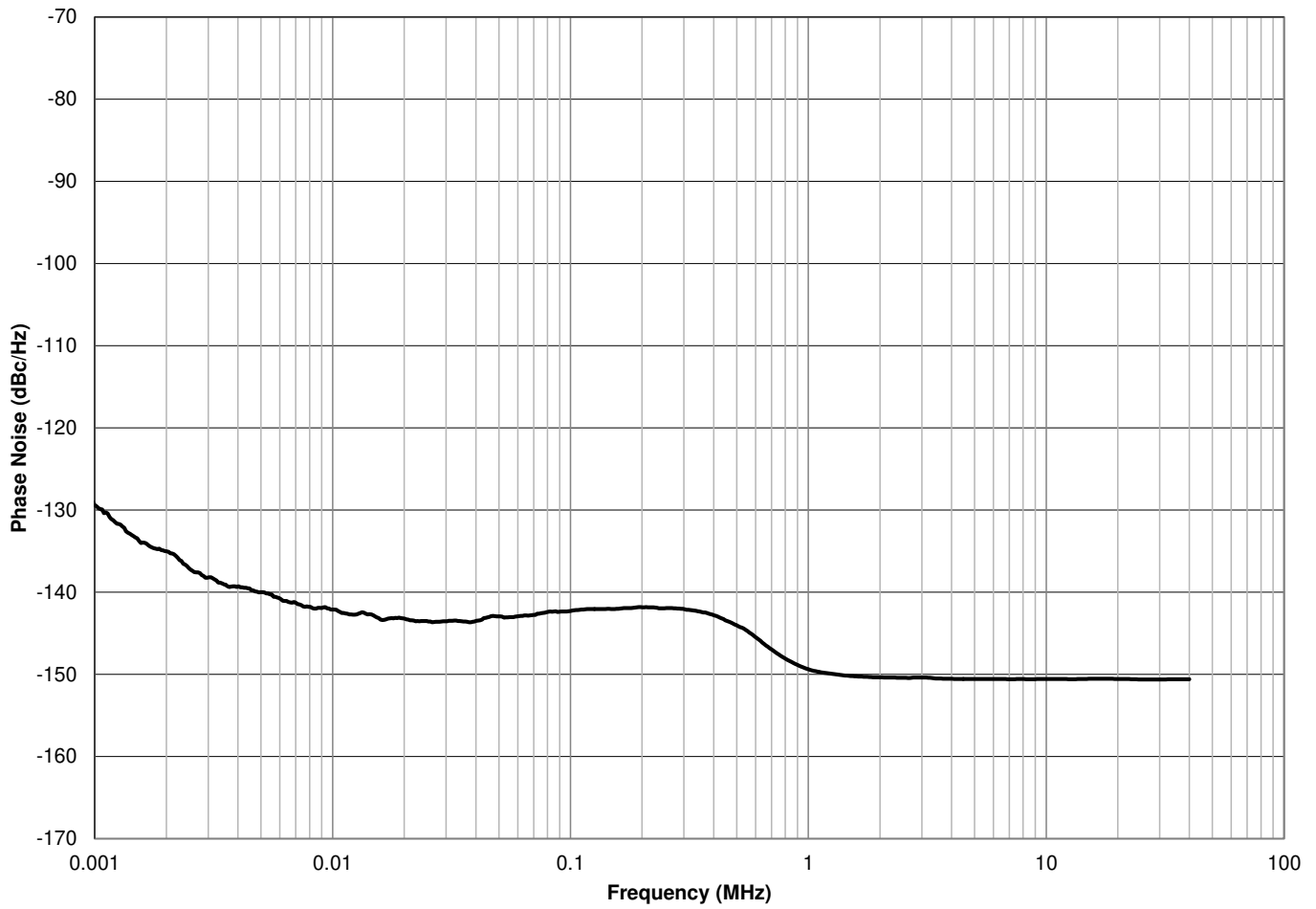

Phase Noise at 622MHz over 12kHz to 20MHz
Additive RMS Phase Jitter: 46fs_{RMS}

Input Interface Applications

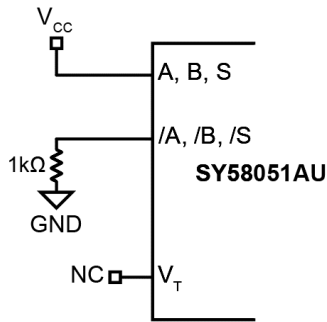

NOTE: INPUT HIGH LEVEL SHOWN

Figure 5. Static Input Level

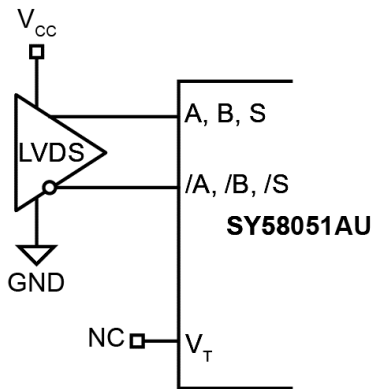
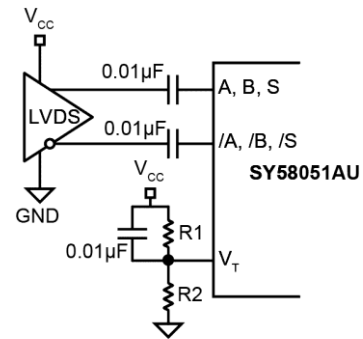

Figure 6. LVDS Interface (DC-Coupled)



NOTE: R1 = 1kΩ, R2 = 1.4kΩ

Figure 7. LVDS Interface (AC-Coupled)

Note: Be certain that the LVDS driver can be AC-coupled.

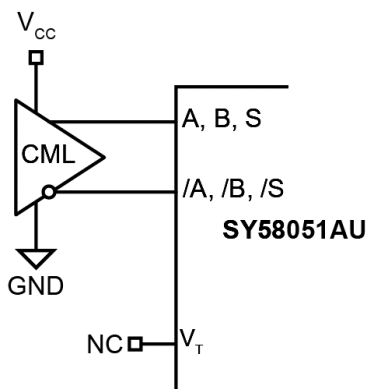
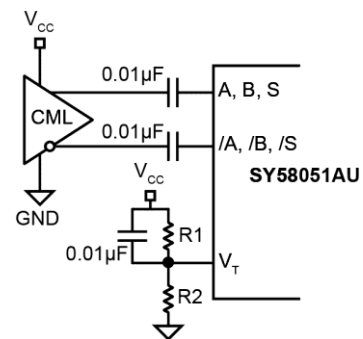

Figure 8. CML Interface (DC-Coupled)



NOTE: R1 = 1kΩ, R2 = 1.4kΩ

Figure 9. CML Interface (AC-Coupled)

Input Interface Applications (Continued)

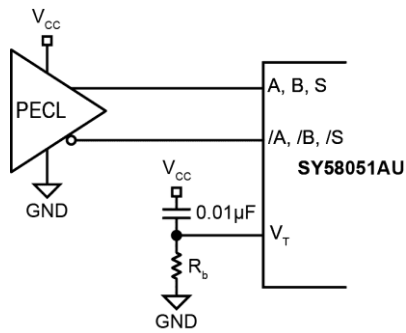

NOTE: $R_b = 50\Omega$

Figure 10. PECL Interface (DC-Coupled)

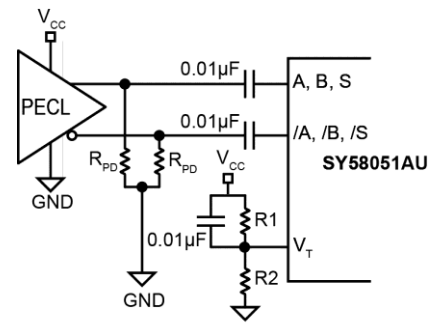

NOTE: FOR 2.5V, $R_{PD} = 50\Omega$, $R1 = 1k\Omega$, $R2 = 1.4k\Omega$
 FOR 3.3V, $R_{PD} = 100\Omega$, $R1 = 1k\Omega$, $R2 = 1.4k\Omega$

Figure 11. PECL Interface (AC-Coupled)

Related Product and Support Documentation

Part Number	Function	Datasheet Link
SY58016L	3.3V 10Gbps Differential CML Line Driver/Receiver with Internal Termination	http://www.micrel.com/PDF/HBW/sy58016l.pdf
SY58052AU	10.7Gbps Clock/Data Retimer with 50Ω Input Termination	http://www.micrel.com/PDF/HBW/SY58052AU.pdf
TCG Solutions	New Products and Applications	http://www.micrel.com/index.php/en/products/clock-timing.html

Package Information⁽¹⁷⁾

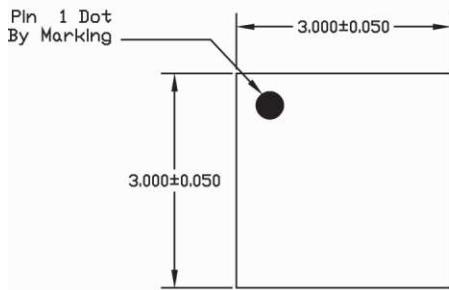

TOP VIEW

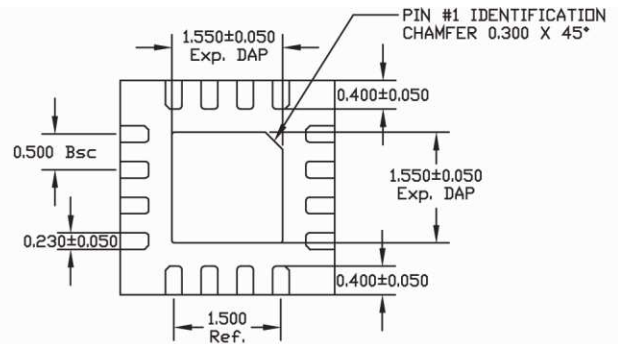

BOTTOM VIEW

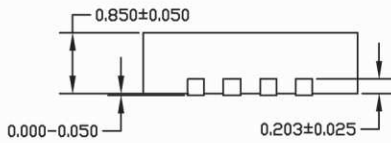

SIDE VIEW

- NOTE:
1. ALL DIMENSIONS ARE IN MILLIMETERS.
 2. MAX. PACKAGE WARPAGE IS 0.05 mm.
 3. MAXIMUM ALLOWABLE BURRS IS 0.076 mm IN ALL DIRECTIONS.
 4. PIN #1 ID ON TOP WILL BE LASER/INK MARKED.

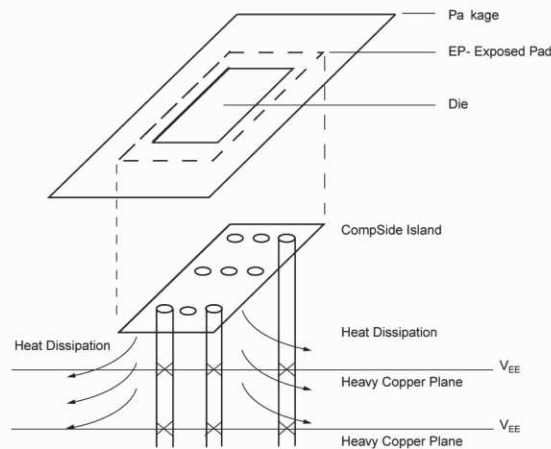

16-Pin QFN

Note:

17. Package information is correct as of the publication date. For updates and most current information, go to www.micrel.com.

MICREL, INC. 2180 FORTUNE DRIVE SAN JOSE, CA 95131 USATEL +1 (408) 944-0800 FAX +1 (408) 474-1000 WEB <http://www.micrel.com>

Micrel makes no representations or warranties with respect to the accuracy or completeness of the information furnished in this data sheet. This information is not intended as a warranty and Micrel does not assume responsibility for its use. Micrel reserves the right to change circuitry, specifications and descriptions at any time without notice. No license, whether express, implied, arising by estoppel or otherwise, to any intellectual property rights is granted by this document. Except as provided in Micrel's terms and conditions of sale for such products, Micrel assumes no liability whatsoever, and Micrel disclaims any express or implied warranty relating to the sale and/or use of Micrel products including liability or warranties relating to fitness for a particular purpose, merchantability, or infringement of any patent, copyright or other intellectual property right.

Micrel Products are not designed or authorized for use as components in life support appliances, devices or systems where malfunction of a product can reasonably be expected to result in personal injury. Life support devices or systems are devices or systems that (a) are intended for surgical implant into the body or (b) support or sustain life, and whose failure to perform can be reasonably expected to result in a significant injury to the user. A Purchaser's use or sale of Micrel Products for use in life support appliances, devices or systems is a Purchaser's own risk and Purchaser agrees to fully indemnify Micrel for any damages resulting from such use or sale.

© 2014 Micrel, Incorporated.