



Chipsmall Limited consists of a professional team with an average of over 10 year of expertise in the distribution of electronic components. Based in Hongkong, we have already established firm and mutual-benefit business relationships with customers from,Europe,America and south Asia,supplying obsolete and hard-to-find components to meet their specific needs.

With the principle of "Quality Parts,Customers Priority,Honest Operation,and Considerate Service",our business mainly focus on the distribution of electronic components. Line cards we deal with include Microchip,ALPS,ROHM,Xilinx,Pulse,ON,Everlight and Freescale. Main products comprise IC,Modules,Potentiometer,IC Socket,Relay,Connector.Our parts cover such applications as commercial,industrial, and automotives areas.

We are looking forward to setting up business relationship with you and hope to provide you with the best service and solution. Let us make a better world for our industry!



Contact us

Tel: +86-755-8981 8866 Fax: +86-755-8427 6832

Email & Skype: info@chipsmall.com Web: www.chipsmall.com

Address: A1208, Overseas Decoration Building, #122 Zhenhua RD., Futian, Shenzhen, China



FEATURES

- Up to 622Mbps operation
- Modulation current to 25mA
- PECL output enable
- Differential PECL inputs
- Single 5V power supply
- Available in a tiny 10-pin (3mm) MSOP

DESCRIPTION

The SY88702 is a high-speed current switch for driving a semiconductor laser diode in optical transmission applications. The modulation current (I_{OUT}) is controlled by the current (I_{RSET}) through the external resistor R_{SET} . The output OUT is HIGH and no current flows through OUT when output enable is HIGH.

The device incorporates complementary open collector outputs with 25mA maximum current driving capability. The external resistor R_{EXT} must be placed between /OUT and V_{CC} to dissipate the worst case power. R_{SER} is recommended to compensate for laser diode matching issues.

The SY88702 utilizes the high performance bipolar ASSET™ technology.

APPLICATIONS

- 622Mbps SONET

FUNCTIONAL BLOCK DIAGRAM

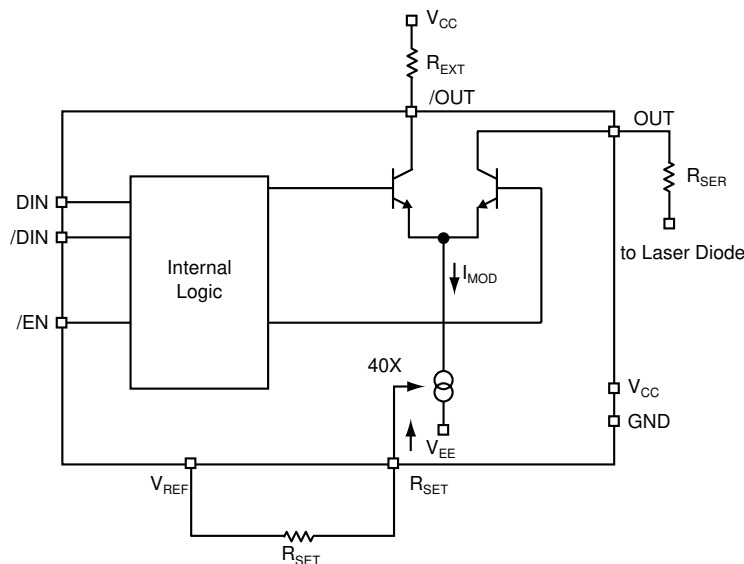

PACKAGE/ORDERING INFORMATION

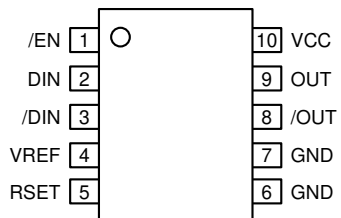

**10-Pin MSOP
(K10-1)**

Ordering Information

Part Number	Package Type	Operating Range	Package Marking
SY88702KC	K10-1	Commercial	702
SY88702KCTR*	K10-1	Commercial	702
SY88702KI	K10-1	Industrial	702
SY88702KITR*	K10-1	Industrial	702

*Tape and Reel

PIN DESCRIPTION

Pin Number	Pin Name	Pin Function
1	/EN	100k PECL compatible input with 75kΩ pull-down resistor. Modulation current goes to zero when deasserted high.
2, 3	DIN, /DIN	Differential 100k PECL compatible input with 75kΩ pull-down resistors.
4	VREF	Voltage reference for use with R _{SET} .
5	RSET	An external resistor connected from here to V _{REF} sets the reference current for I _{OUT} .
6, 7	GND	Device ground.
9, 8	OUT, /OUT	Differential open collector current outputs.
10	VCC	Positive power supply.

TRUTH TABLE⁽¹⁾

D	/D	/EN	OUT ⁽²⁾	/OUT
L	H	L	H	L
H	L	L	L	H
X	X	H	H	L

Note 1. L = LOW, H = HIGH, X = don't care.

Note 2. H = I_{OUT} = 0mA.

Absolute Maximum Ratings^(Note 1)

Power Supply Voltage (V_{CC}) 0V to +7.0V
 Input Voltage (V_{IN}) 0V to V_{CC}
 Output Current (I_{OUT}) 25mA
 Power Dissipation (P_D) 250mW
 Storage Temperature Range (T_S) -55°C to +125°C

Operating Ratings^(Notes 2,3,4)

Supply Voltage (V_{CC}) +4.5V to +5.5V
 Ambient Temperature (T_A), **Note 5** -40°C to +85°C
 Junction Temperature (T_J), **Note 5** -40°C to 100°C
 Resistor to Dissipate Power (R_{EXT}) 10Ω to 50Ω
 Laser Diode Serial Resistor (R_{SER}) 0Ω to 50Ω
 Resistor to Adjust Current (R_{SET}) 1500Ω to 50,000Ω
 Package Thermal Resistance
 MSOP
 (θ_{JA}) Still-Air 113°C/W
 (ψ_{JB}) Still-Air 74°C/W

DC ELECTRICAL CHARACTERISTICS

GND = 0V; V_{CC} = 5V ±10%; T_A = -40°C to +85°C

Symbol	Parameter	Condition	Min	Typ	Max	Units
V_{IH}	Input HIGH Voltage (D_{IN} , $/D_{IN}$, $/EN$)		$V_{CC}-1.165$		$V_{CC}-0.880$	V
V_{IL}	Input LOW Voltage (D_{IN} , $/D_{IN}$, $/EN$)		$V_{CC}-1.810$		$V_{CC}-1.475$	V
V_{REF}	Reference Voltage			3.00		V
I_{IL}	Input LOW Current (D_{IN} , $/D_{IN}$, $/EN$)	$V_{IN} = V_{IL}(\text{min})$	0.5			μA
I_{IH}	Input HIGH Current (D_{IN} , $/D_{IN}$, $/EN$)				100	μA
I_{CC}	Supply Current	$I_{MOD} = 25\text{mA}$		16	25	mA
I_{OUT_OFF}	Output LOW Current ($/EN = \text{HIGH}$)				500	μA
I_{OUT}	Modulation Current		5	15	25	mA
A_{RSET}	I_{OUT}/I_{RSET}		30	38	44	—
V_{OUT}	Voltage at OUT, $/OUT$		$V_{CC}-2.3$		V_{CC}	V
C_{OUT}	Capacitance on OUT, $/OUT$			2.5		pF

Note 1. Permanent device damage may occur if ABSOLUTE MAXIMUM RATINGS are exceeded. This is a stress rating only and functional operation is not implied at conditions other than those detailed in the operational sections of this data sheet. Exposure to ABSOLUTE MAXIMUM RATING conditions for extended periods may affect device reliability.

Note 2. The data sheet limits are not guaranteed if the device is operated beyond the operating ratings.

Note 3. The device is guaranteed to meet the DC specifications, shown in the table above, after thermal equilibrium has been established. The device is tested in a socket such that transverse airflow of ≥500lfpm is maintained.

Note 4. The voltage drop across R_{EXT} and R_{SER} plus Laser Diode must not be greater than 2.3V.

Note 5. Commercial devices are guaranteed from 0°C to +85°C ambient temperature.

AC ELECTRICAL CHARACTERISTICS(Note 1)

GND = 0V; V_{CC} = 5V ±10%; T_A = -40°C to +85°C

Symbol	Parameter	Condition	Min	Typ	Max	Units
t _{PHL} , t _{PLH} D	Propagation Delay D _{IN} – OUT	I _{OUT} = 10mA			1000	ps
t _{PHL} , t _{PLH} EN	Propagation Delay /EN – OUT	I _{OUT} = 10mA			1000	ps
t _r t _f	Rise/Fall Time (20% to 80%)				400	ps
I _{OR}	Output Current Ringing	I _{OUT} = 5 to 25mA			10	%

Note 1. R_{EXT} = R_{SER} = 50Ω ±1%; R_{SER} connected directly to V_{CC}.

TYPICAL OPERATING CHARACTERISTICS

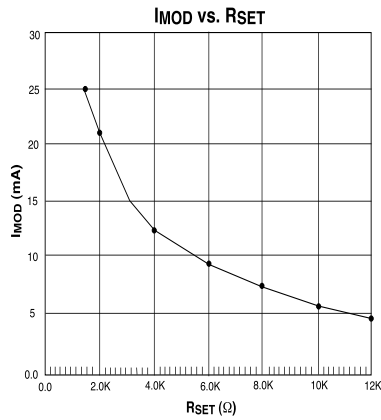

10 LEAD MSOP (K10-1)

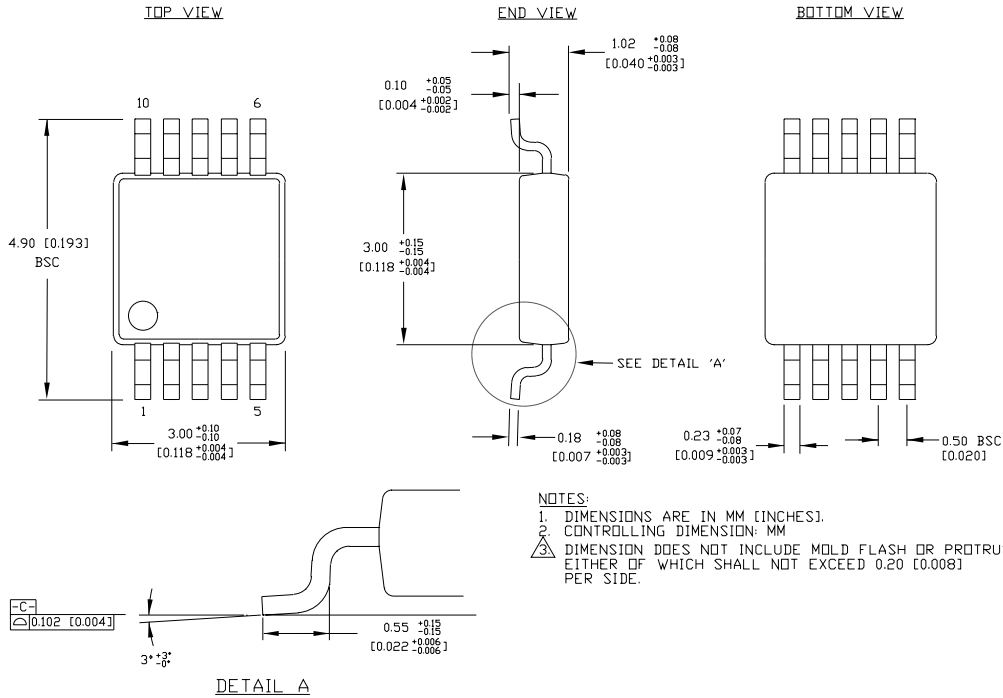

Rev. 00

MICREL, INC. 1849 FORTUNE DRIVE SAN JOSE, CA 95131 USA

TEL + 1 (408) 944-0800 FAX + 1 (408) 944-0970 WEB <http://www.micrel.com>

The information furnished by Micrel in this datasheet is believed to be accurate and reliable. However, no responsibility is assumed by Micrel for its use. Micrel reserves the right to change circuitry and specifications at any time without notification to the customer.

Micrel Products are not designed or authorized for use as components in life support appliances, devices or systems where malfunction of a product can reasonably be expected to result in personal injury. Life support devices or systems are devices or systems that (a) are intended for surgical implant into the body or (b) support or sustain life, and whose failure to perform can be reasonably expected to result in a significant injury to the user. A Purchaser's use or sale of Micrel Products for use in life support appliances, devices or systems is at Purchaser's own risk and Purchaser agrees to fully indemnify Micrel for any damages resulting from such use or sale.