



Chipsmall Limited consists of a professional team with an average of over 10 year of expertise in the distribution of electronic components. Based in Hongkong, we have already established firm and mutual-benefit business relationships with customers from,Europe,America and south Asia,supplying obsolete and hard-to-find components to meet their specific needs.

With the principle of "Quality Parts,Customers Priority,Honest Operation,and Considerate Service",our business mainly focus on the distribution of electronic components. Line cards we deal with include Microchip,ALPS,ROHM,Xilinx,Pulse,ON,Everlight and Freescale. Main products comprise IC,Modules,Potentiometer,IC Socket,Relay,Connector.Our parts cover such applications as commercial,industrial, and automotives areas.

We are looking forward to setting up business relationship with you and hope to provide you with the best service and solution. Let us make a better world for our industry!



Contact us

Tel: +86-755-8981 8866 Fax: +86-755-8427 6832

Email & Skype: info@chipsmall.com Web: www.chipsmall.com

Address: A1208, Overseas Decoration Building, #122 Zhenhua RD., Futian, Shenzhen, China



FEATURES

- Up to 1.25Gbps operation
- Low noise
- Chatter-Free LOS Generation
- Open Collector TTL LOS Output
- TTL /EN Input
- Differential PECL inputs for data
- Single power supply
- Designed for use with SY88902 and SY88904
- Available in a tiny 10-pin (3mm) MSOP

APPLICATIONS

- 1.25Gbps Gigabit Ethernet
- 531Mbps and 1062Mbps Fibre Channel
- 622Mbps SONET
- Gigabit Interface Converter

DESCRIPTION

The SY88903 limiting post amplifier with its high gain and wide bandwidth is ideal for use as a post amplifier in fiber-optic receivers with data rates up to 1.25Gbps. Signals as small as 5mVp-p can be amplified to drive devices with PECL inputs. The SY88903 generates a chatter-free Loss of Signal (LOS) open collector TTL output.

The SY88903 incorporates a programmable level detect function to identify when the input signal has been lost. This information can be fed back to the /EN input of the device to maintain stability under loss of signal conditions. Using LOSLVL pin the sensitivity of the level detect can be adjusted. The LOSLVL voltage can be set by connecting a resistor divider between VCC and VREF, Figure 3. Figure 4 shows the relationship between input level sensitivity and the voltage set on LOSLVL. Figure 5 shows the relationship between input level sensitivity and resistor divider ratio.

The LOS output is a TTL open collector output that requires pull-up resistor for proper operation, Figure 1.

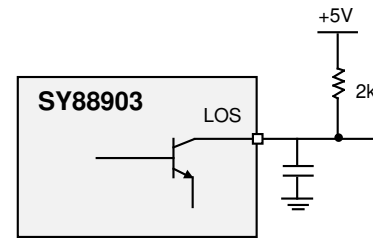
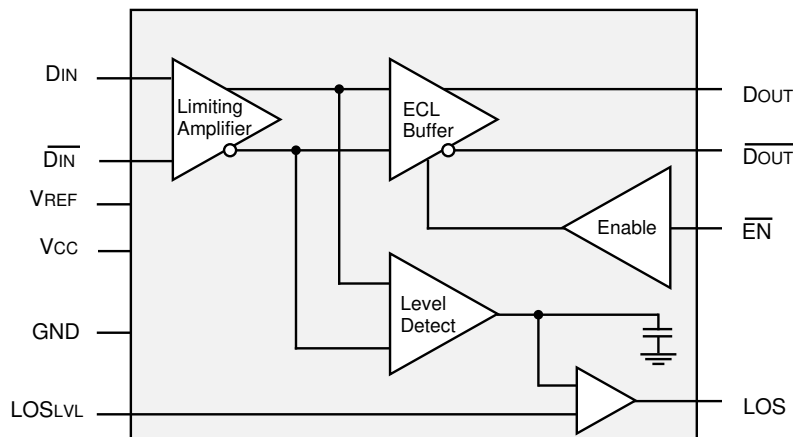
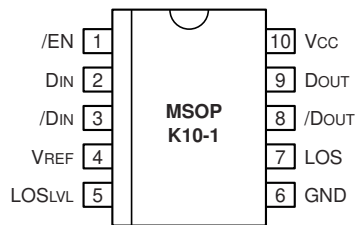

Figure 1. LOS Output with Desired Rise Time

BLOCK DIAGRAM



PACKAGE/ORDERING INFORMATION



10-Pin MSOP (K10-1)

Ordering Information

Part Number	Package Type	Operating Range	Package Marking	Lead Finish
SY88903KC	K10-1	Commercial	903	Sn-Pb
SY88903KCTR(1)	K10-1	Commercial	903	Sn-Pb
SY88903KH	K10-1	Commercial	903 with Pb-Free bar-line indicator	Pb-Free NiPdAu
SY88903KHTR(1)	K10-1	Commercial	903 with Pb-Free bar-line indicator	Pb-Free NiPdAu

Note:

1. Tape and Reel.

PIN NAMES

Pin	Type	Function
DIN	Data Input	Data Input
/DIN	Data Input	Inverting Data Input
LOS LVL	Input	Loss of Signal Level Set
/EN	TTL Input	Output Enable (active Low)
LOS	TTL Output (Open Collector)	Loss of Signal Indicator (active High)
GND	Ground	Ground
DOUT	PECL Output	Data Output
/DOUT	PECL Output	Inverting Data Output
VCC	Power Supply	Positive Power Supply
VREF	Output	Reference Voltage Output for LOS Level Set (see Fig. 3)

GENERAL DESCRIPTION

General

The SY88903 is an integrated limiting amplifier intended for high-frequency fiber-optic applications. The circuit connects to typical transimpedance amplifiers found within a fiber-optics link. The linear signal output from a transimpedance amplifier can contain significant amounts of noise, and may vary in amplitude over time. The SY88903 limiting amplifier quantizes the signal and outputs a voltage-limited waveform.

The TTL /EN pin allows the user to disable the output signal without removing the input signal.

ABSOLUTE MAXIMUM RATINGS⁽¹⁾

Symbol	Rating	Value	Unit
VCC	Power Supply Voltage	0 to +7.0	V
DIN, /DIN	Input Voltage	0 to VCC	V
DOUT, /DOUT	Output Voltage (with 50Ω load)	VCC -2.5, VCC +0.3	V
TA	Operating Temperature Range	-40 to +85	°C
Tstore	Storage Temperature Range	-55 to +125	°C

Note:

1. Permanent device damage may occur if absolute maximum ratings are exceeded. This is a stress rating only and functional operation is not implied at conditions other than those detailed in the operational sections of this data sheet. Exposure to absolute maximum rating conditions for extended periods may affect device reliability.

DC ELECTRICAL CHARACTERISTICS

VCC = +5V ±10%, RLOAD = 50Ω to VCC-2V, TA = -40°C to +85°C

Symbol	Parameter	TA = -40°C		TA = 0°C		TA = +25°C			TA = +85°C		Unit
		Min.	Max.	Min.	Max.	Min.	Typ.	Max.	Min.	Max.	
ICC	Power Supply Current ⁽¹⁾	—	35	—	35	—	21	35	—	35	mA
IIL	/EN Input LOW Current	-0.3	—	-0.3	—	-0.3	—	—	-0.3	—	mA
IiH	/EN Input HIGH Current	—	20 ⁽⁵⁾ 100 ⁽⁶⁾	—	20 ⁽⁵⁾ 100 ⁽⁶⁾	—	—	20 ⁽⁵⁾ 100 ⁽⁶⁾	—	20 ⁽⁵⁾ 100 ⁽⁶⁾	μA
VCMR	Common Mode Range	GND +2.0	VCC -1.0	GND +2.0	VCC -1.0	GND +2.0	—	VCC -1.0	GND +2.0	VCC -1.0	V
Voffset	Differential Output Offset	—	±100	—	±100	—	—	±100	—	±100	mV
LOSLVL	LOSLVL Level	VREF	VCC	VREF	VCC	VREF	—	VCC	VREF	VCC	V
VOL	LOS Output Low Level ⁽²⁾	—	0.5	—	0.5	—	—	0.5	—	0.5	V
IoH	LOS Output Leakage ⁽³⁾	—	250	—	250	—	—	250	—	250	μA
VOH	DOUT and /DOUT HIGH Output	VCC-1085	VCC-880	VCC-1025	VCC-880	VCC-1025	VCC-955	VCC-880	VCC-1025	VCC-880	mV
VOL	DOUT and /DOUT LOW Output	VCC-1830	VCC-1555	VCC-1810	VCC-1620	VCC-1810	VCC-1705	VCC-1620	VCC-1810	VCC-1620	mV
VREF	Reference Supply ⁽⁴⁾	VCC-2.625	VCC-2.325	VCC-2.625	VCC-2.325	VCC-2.625	VCC-2.475	VCC-2.325	VCC-2.625	VCC-2.325	V
VIH	/EN Input HIGH Voltage	2.0	—	2.0	—	2.0	—	—	2.0	—	V
VIL	/EN Input LOW Voltage	—	0.8	—	0.8	—	—	0.8	—	0.8	V

Notes:

1. No output load
2. IOL = + 2mA
3. VOH = 5.5V

4. IREF must be limited to be within -0.8mA (source) and 0.5mA (sink).
5. VIN = 2.7V
6. VIN = VCC

AC ELECTRICAL CHARACTERISTICS

VCC = +5V ±10%, RLOAD = 50Ω to VCC - 2V, TA = -40°C to +85°C

Symbol	Parameter	TA = -40°C		TA = 0°C		TA = +25°C			TA = +85°C		Unit	Conditions
		Min.	Max.	Min.	Max.	Min.	Typ.	Max.	Min.	Max.		
PSRR	Power Supply ⁽¹⁾ Rejection Ratio	—	—	—	—	—	35	—	—	—	dB	Input referred, 55MHz
VID	Input Voltage Range	5	1800	5	1800	5	—	1800	5	1800	mV _{PP}	
tr, tf	Output Rise/Fall Time	—	350	—	350	—	200 trin, tfin	350	—	350	ps	VID > 100mV _{PP} VID < 100mV _{PP}
VOD	Differential Output Voltage Swing ⁽²⁾	—	—	—	—	—	600 200	—	—	—	mV mV	VID = 15mV _{PP} VID = 5mV _{PP}
tOFFL	LOS Release Time ⁽³⁾ Minimum Input	—	0.5	—	0.5	—	0.1	0.5	—	0.5	μs	
tOFFH	LOS Release Time ⁽⁴⁾ Maximum Input	—	0.5	—	0.5	—	0.1	0.5	—	0.5	μs	
tONL	LOS Assert Time ⁽³⁾	—	0.5	—	0.5	—	0.2	0.5	—	0.5	μs	
VSR	LOS Sensitivity Range	5	50	5	50	5	—	50	5	50	mV _{PP}	
HYS	LOS Hysteresis	2	8	2	8	2	4.6	8	2	8	dB	

Notes:

1. Input referred noise = RMS output noise/low frequency gain.
2. Input is 622MHz square wave.

3. Input is a 200MHz square wave, tr < 300ps, 8mVp-p.
4. Input is a 200MHz square wave, tr < 300ps, 1.8Vp-p.

APPLICATION INFORMATION

Output Termination

The SY88903 outputs must be terminated with a 50Ω load to VCC – 2V (or Thevenin equivalent).

Layout and PCB Design

Since the SY88903 is a high-frequency component, performance can largely be determined by board layout and design. A common problem with high-gain amplifiers is feedback from the large swing outputs to the input via the power supply.

The SY88903 ground pin should be connected to the circuit board ground. Use multiple PCB vias close to the part to connect to ground. Avoid long, inductive runs which can degrade performance.

NOTES:

Resistor Divider = $R2 / (R1 + R2)$
 $R1 + R2 \geq 5k\Omega$

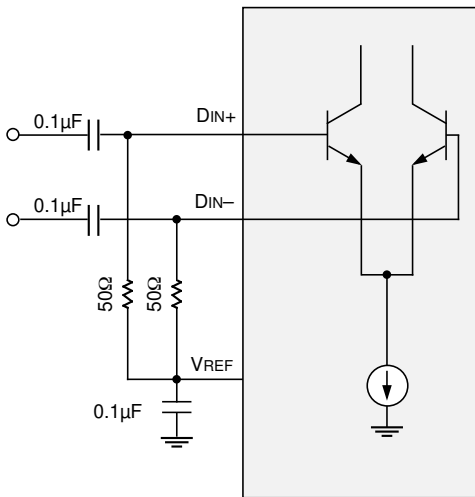

Figure 2. Differential Input Configuration

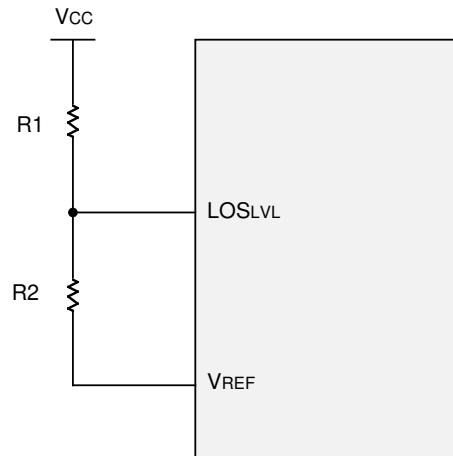

Figure 3. LOSLVL Circuit

PERFORMANCE CURVE

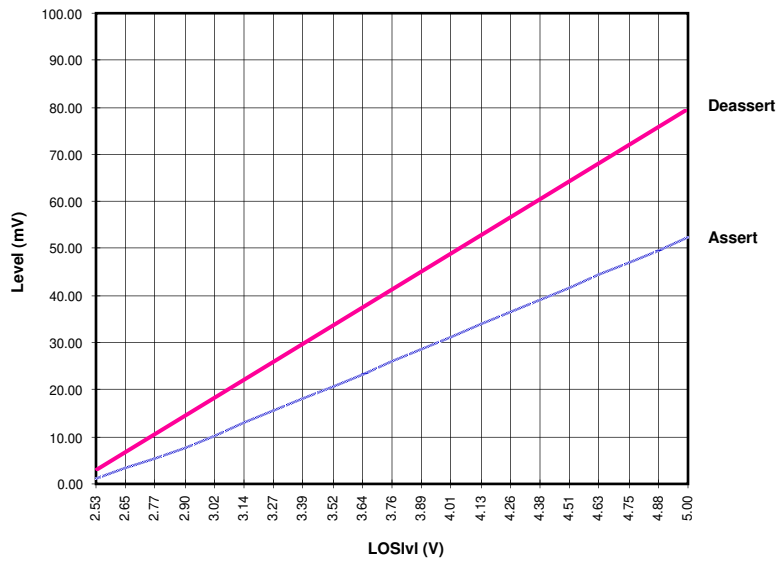

Figure 4. LOS Assert and Deassert Levels vs LOSLVL

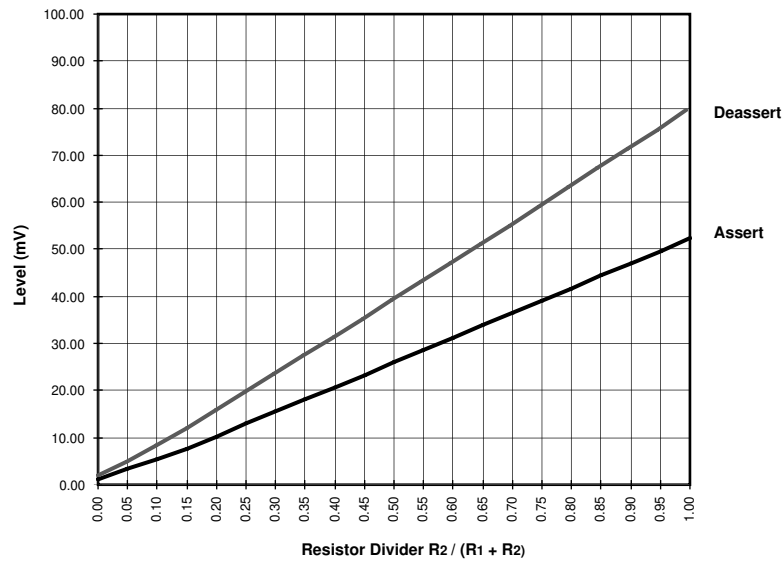
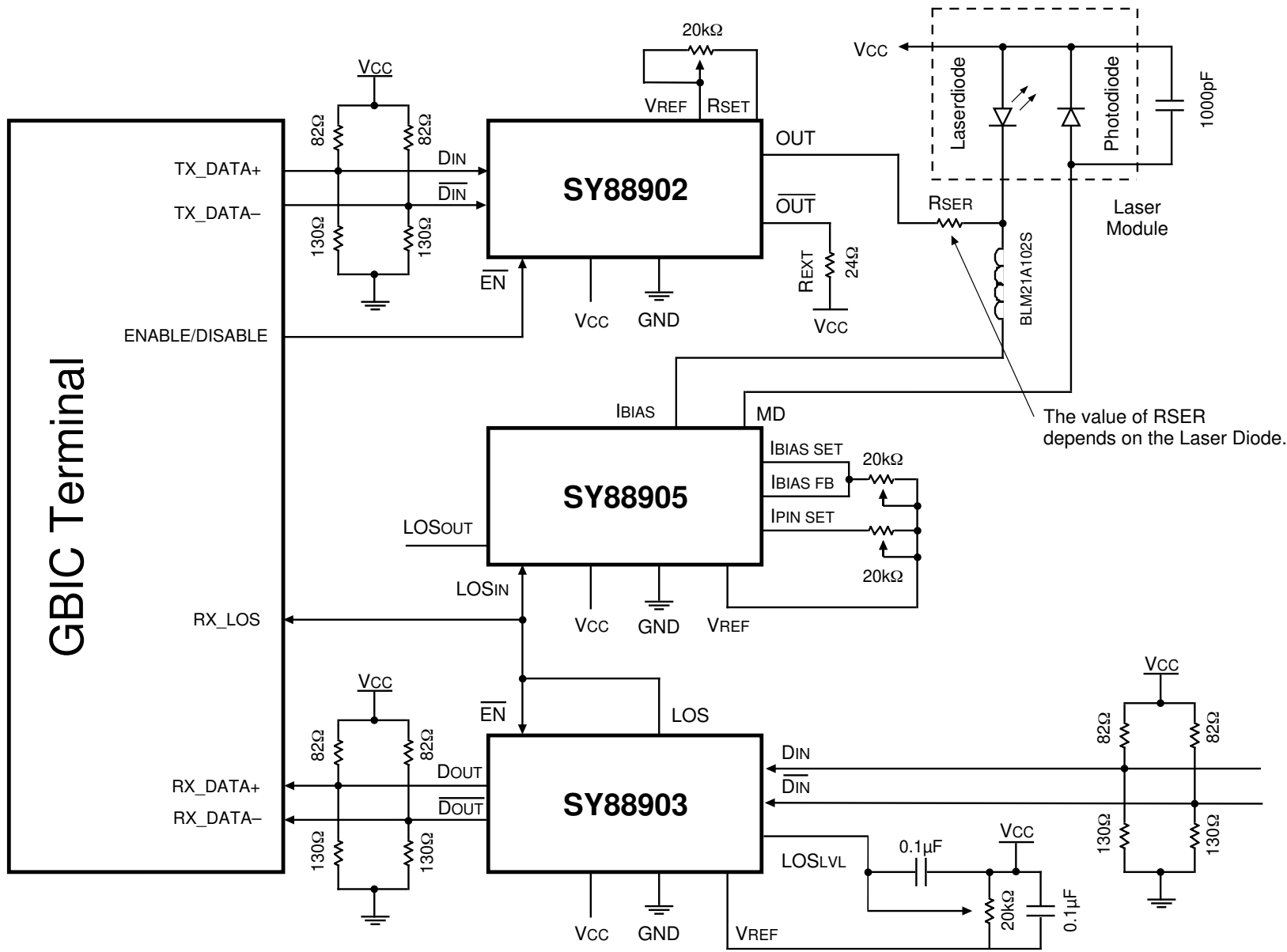
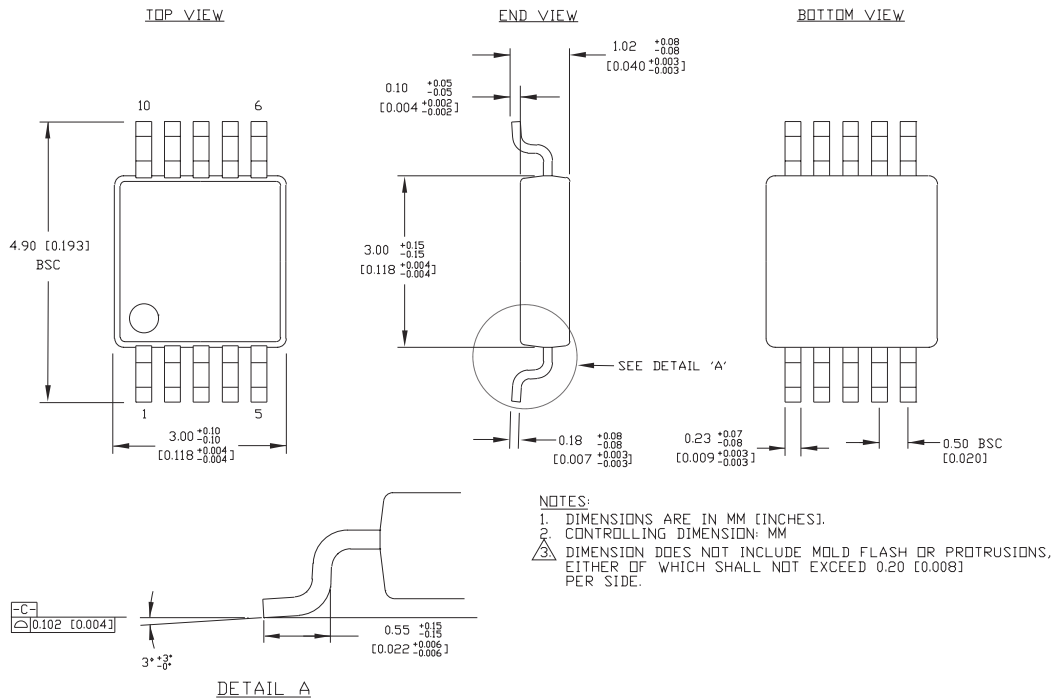

Figure 5. LOS Assert and Deassert Levels vs Resistor Divider

APPLICATION EXAMPLE FOR 3-CHIP SET SOLUTION



10 LEAD MSOP (K10-1)



Rev. 00

MICREL, INC. 2180 FORTUNE DRIVE SAN JOSE, CA 95131 USA

TEL + 1 (408) 944-0800 FAX + 1 (408) 474-1000 WEB <http://www.micrel.com>

The information furnished by Micrel in this data sheet is believed to be accurate and reliable. However, no responsibility is assumed by Micrel for its use. Micrel reserves the right to change circuitry and specifications at any time without notification to the customer.

Micrel Products are not designed or authorized for use as components in life support appliances, devices or systems where malfunction of a product can reasonably be expected to result in personal injury. Life support devices or systems are devices or systems that (a) are intended for surgical implant into the body or (b) support or sustain life, and whose failure to perform can be reasonably expected to result in a significant injury to the user. A Purchaser's use or sale of Micrel Products for use in life support appliances, devices or systems is at Purchaser's own risk and Purchaser agrees to fully indemnify Micrel for any damages resulting from such use or sale.

© 2005 Micrel, Incorporated.