



Chipsmall Limited consists of a professional team with an average of over 10 year of expertise in the distribution of electronic components. Based in Hongkong, we have already established firm and mutual-benefit business relationships with customers from,Europe,America and south Asia,supplying obsolete and hard-to-find components to meet their specific needs.

With the principle of “Quality Parts,Customers Priority,Honest Operation,and Considerate Service”,our business mainly focus on the distribution of electronic components. Line cards we deal with include Microchip,ALPS,ROHM,Xilinx,Pulse,ON,Everlight and Freescale. Main products comprise IC,Modules,Potentiometer,IC Socket,Relay,Connector.Our parts cover such applications as commercial,industrial, and automotives areas.

We are looking forward to setting up business relationship with you and hope to provide you with the best service and solution. Let us make a better world for our industry!



Contact us

Tel: +86-755-8981 8866 Fax: +86-755-8427 6832

Email & Skype: info@chipsmall.com Web: www.chipsmall.com

Address: A1208, Overseas Decoration Building, #122 Zhenhua RD., Futian, Shenzhen, China



MICRO SWITCH Miniature Industrial Limit Switch

SZL-VL-S Series

002389
Issue 3



DESCRIPTION

The SZL-VL-S Series miniature-type limit switch is designed for use in applications where limited mounting space is available. With IP67 seal rating, these switches are suitable for OEM machinery that requires a rugged and reliable limit switch capable of being mounted in space restricted applications. Its design enhances ease of wiring with ample wiring space, and has an optional cable gland for faster and more efficient wiring termination.

The SZL-VL-S Series switches have a split-housing design made of a die-cast body and head with glass-filled, flame-retardant thermoplastic cover. The cover is removable for easy access and ease of installation. Modular actuator head design allows for configurations to meet a variety of application needs. The SZL-VL-S are available globally and carry certifications for applications around the world.

DIFFERENTIATION

- With robust environmental ratings, the SZL-VL-S is protected for all kinds of industrial applications. IP67 indicates that the SZL-VL-S is protected against the effect of immersion in water between 15 cm and 1 m. The competition standard is IP65 which can only withstand low pressure spray and jets of water.
- The electrical rating of 10 A permits the SZL-VL-S switch to be used with heavier electrical loads than competitors

VALUE TO CUSTOMERS

- These switches are user-friendly interfaces and may be used in a broad range of applications to help meet the challenges of many industrial environments.
- A variety of actuators fit on the same platform reducing the need to use various kinds of mounting hardware.

FEATURES

- Approvals: CCC, CE, cULus
- Sealed to IP67, NEMA 1, 12, 13
- Snap-action contacts
- Die-cast metal housing with glass-filled, flame-retardant thermoplastic cover
- Stainless steel levers with either steel and nylon rollers
- Variety of actuators
- Positive-opening contacts (side rotary version only)
- RoHS compliant
- Utilization category: AC-15 A300 (380 Vac/0.5 A)
DC-13 Q300 (220 Vdc/0.05 A)
- Mechanical life rating: 10 million cycles
- Electrical life rating: 0.5 million cycles

APPLICATIONS

- Scissor/boom position detection
- Vehicle accessibility lifts
- Escalators/Motorized walkways
- Machine tools
- Mobile light towers
- Packaging equipment
- Conveyor equipment
- Overhead doors
- Agriculture equipment
- Rail passenger cars (internal doors)

PORTFOLIO

The MICRO SWITCH SZL-VL-S series joins Honeywell's NGC Series and the GLL Series switches for general industrial applications. The combined portfolio helps ensure a variety of industrial applications or position sensing tasks can be performed by a Honeywell limit switch. To view the entire product portfolio, click [here](#).

MICRO SWITCH Miniature Industrial Limit Switch, SZL-VL-S Series

Table 1. Performance Specifications

Characteristic	Parameter
Description	Miniature industrial limit switch
Approvals	CCC, CE, cULus
Housing material	Die-cast metal housing with glass-filled, flame-retardant thermoplastic cover UL 94 flame spread testing: V-0 rated
Electrical connection	Conduit entry or cable gland
Contact design	Snap-action (all versions) Positive-opening contacts (side rotary version only)
Contact material	Silver alloy
Electrical ratings	AC-15 A300 (380 Vac/0.5 A) DC-13 Q300 (220 Vdc/0.05 A)
Thermal current (I_{th})	10 A/250 Vac (EN 60947-5-1)
Initial contact resistance	≤ 25 mOhm
Insulation resistance	>100 MOhm at 500 Vdc
Impulse voltage	2500 Vdc
Dielectric voltage	1890 Vac for metal housing, 1890 Vac between all terminals to enclosure after durability test
Leakage current	≤ 10 mA
Pollution degree	3
Environmental sealing	IP67
Operating temperature	-20°C to 70°C [-4°F to 158°F] (with no icing)
Humidity	95 %RH
Shock	30 G, conforming to IEC 60068-2-27
Vibration	10 G, 10 Hz to 55 Hz displacement amplitude 0,75 mm, conforming to IEC 60068-2-6 (wobble excluded)
MCTF (Mechanical life)	10M cycles @ 120 cpm max.
MCTF (Electrical life)	0.5M cycles @ 30 cpm max. under the rated resistance load
Operating speed	0,05 mm/s to 2 m/s (based on pin plunger limit switch)
Operating frequency	Mechanical: 120 ops/min; Electrical: 30 ops/min
Weight	120 g to 150 g

Figure 1. Circuitry

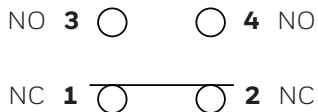

Figure 2. Mounting Holes

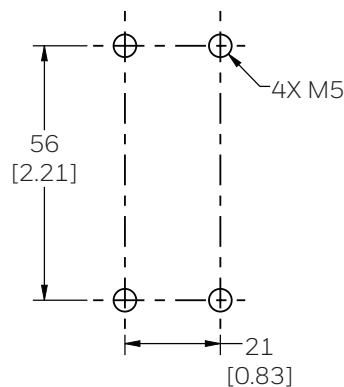
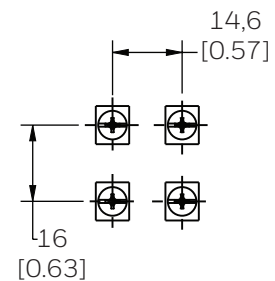
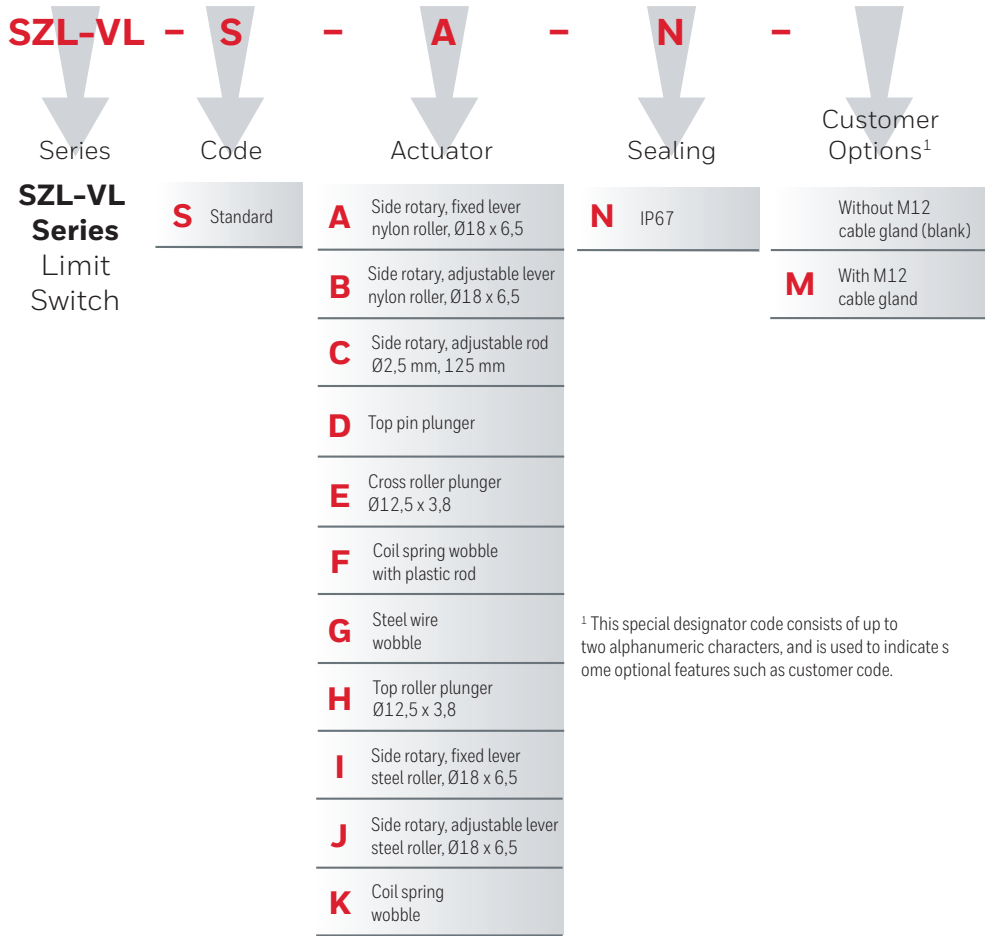

Figure 3. Wiring



MICRO SWITCH Miniature Industrial Limit Switch, SZL-VL-S Series

Figure 4. Product Nomenclature



MICRO SWITCH Miniature Industrial Limit Switch, SZL-VL-S Series

Table 2. Order Guide mm [in]

Catalog listing	Actuator	Roller/pin plunger	Lever	Free position	Pretravel max. mm [in]	Differential travel max. mm [in]	Overtravel min. mm [in]	Min. travel to achieve positive opening	Operating force/torque (max.)	Bar chart
SZL-VL-S-A-N-M	Side rotary, fixed lever	Nylon roller, Ø18 x 6,5 [Ø0.71 x 0.25]	Steel, R30	0°	25°	15°	70°	40°	18 Ncm [1.59 in-lb]	
SZL-VL-S-I-N-M	Side rotary, fixed lever	Steel roller, Ø18 x 6,5 [Ø0.71 x 0.25]	Steel, R30	0°	25°	15°	70°	40°	18 Ncm [1.59 in-lb]	
SZL-VL-S-B-N-M	Side rotary, adjustable lever	Nylon roller, Ø18 x 6,5 [Ø0.71 x 0.25]	Steel, R30 to R70	0°	25°	15°	70°	40°	18 Ncm [1.59 in-lb]	
SZL-VL-S-J-N-M	Side rotary, adjustable lever	Steel roller, Ø18 x 6,5 [Ø0.71 x 0.25]	Steel, R30 to R70	0°	25°	15°	70°	40°	18 Ncm [1.59 in-lb]	
SZL-VL-S-C-N-M	Side rotary, adjustable rod	-	Metal rod, Ø2,5 mm [0.1 in], 125 mm [4.92 in] long	0°	25°	15°	70°	40°	18 Ncm [1.59 in-lb]	
SZL-VL-S-D-N-M	Top pin plunger	Metal pin, Ø6,6 [0.26]	-	27 ±0,8 [1.04 ±0.03]*	2 [0.08]	1,5 [0.06]	3,5 [0.14]	n/a	9 N [2.02 lb]	
SZL-VL-S-H-N-M	Top roller plunger	Steel roller, Ø12,5 x 3,8 [Ø0.5 x 0.15]	-	38,5 ±0,8 [1.5 ±0.03]*	2 [0.08]	1,5 [0.06]	3,5 [0.14]	n/a	9 N [2.02 lb]	
SZL-VL-S-E-N-M	Top cross roller plunger	Steel roller, Ø12,5 x 3,8 [Ø0.5 x 0.15]	-	38,5 ±0,8 [1.5 ±0.03]*	2 [0.08]	1,5 [0.06]	3,5 [0.14]	n/a	9 N [2.02 lb]	
SZL-VL-S-F-N-M	Wobble, coil spring and nylon rod	-	Ø5,8 mm [0.23 in] coil spring with plastic rod	0°	30°	-	20°	n/a	2 N [0.45 lb]	
SZL-VL-S-G-N-M	Wobble, coil spring and metal wire	-	Ø5,8 mm [0.23 in] coil spring with Ø1,2 mm [0.05 in] metal wire	0°	30°	-	20°	n/a	2 N [0.45 lb]	
SZL-VL-S-K-N-M	Wobble, coil spring	-	Ø5,8 mm [0.23 in] coil spring	0°	30°	-	20°	n/a	2 N [0.45 lb]	

* (from the center of the mounting hole)

MICRO SWITCH Miniature Industrial Limit Switch, SZL-VL-S Series

Dimensional Drawings • mm [in]

Figure 5. SZL-VL Side Rotary Limit Switch (Fixed Lever)

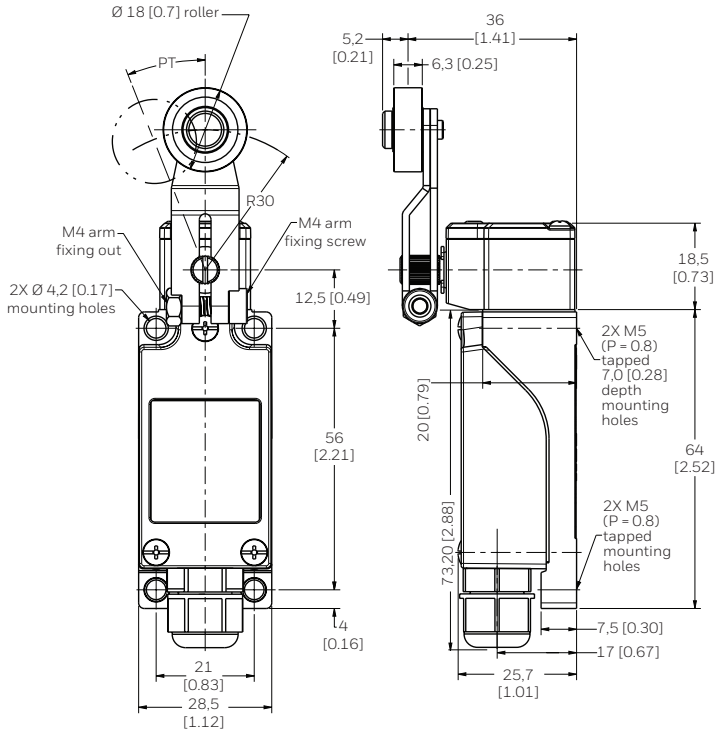

Figure 6. SZL-VL Side Rotary Limit Switch (Adjust. Lever)

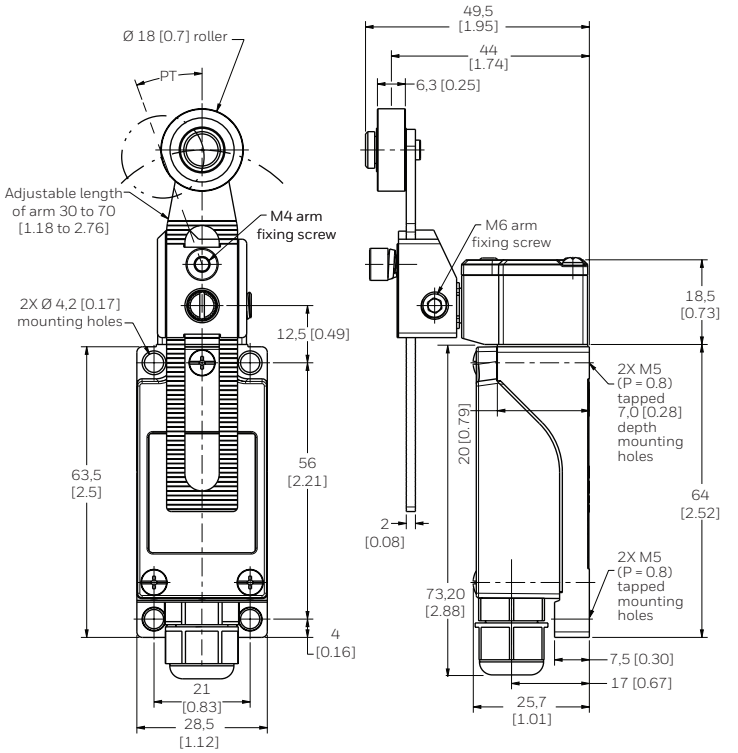

Figure 7. SZL-VL Side Rotary Limit Switch (Adjust. Rod)

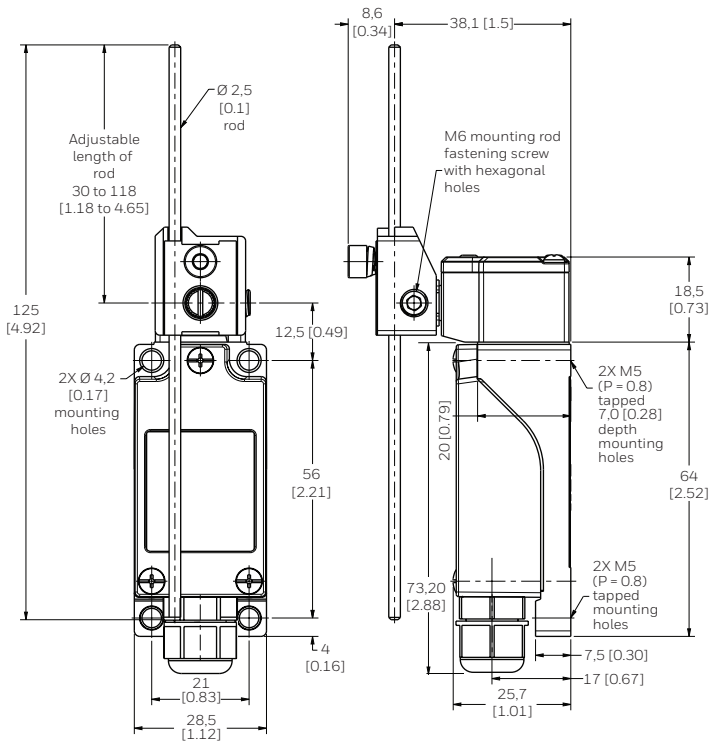
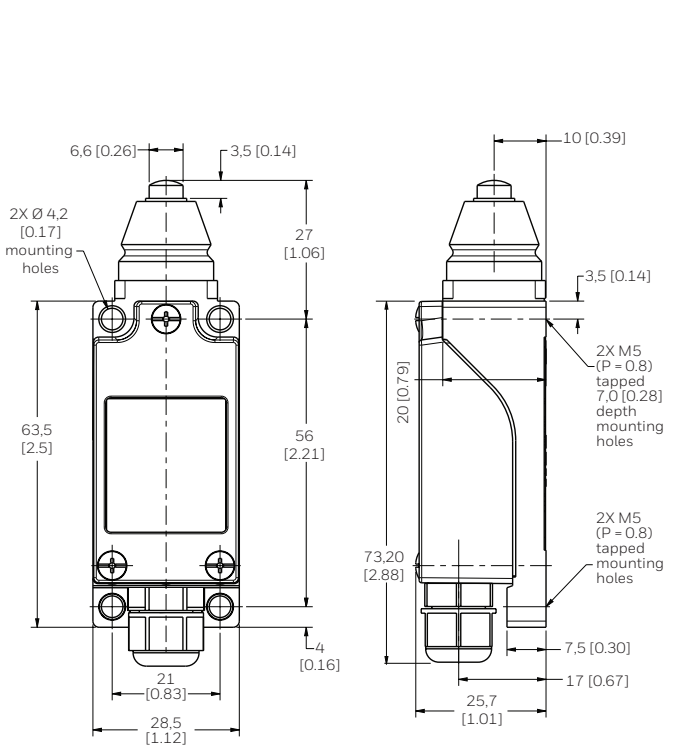

Figure 8. SZL-VL Pin Plunger Limit Switch



MICRO SWITCH Miniature Industrial Limit Switch, SZL-VL-S Series

Figure 9. SZL-VL Cross Roller Plunger Limit Switch

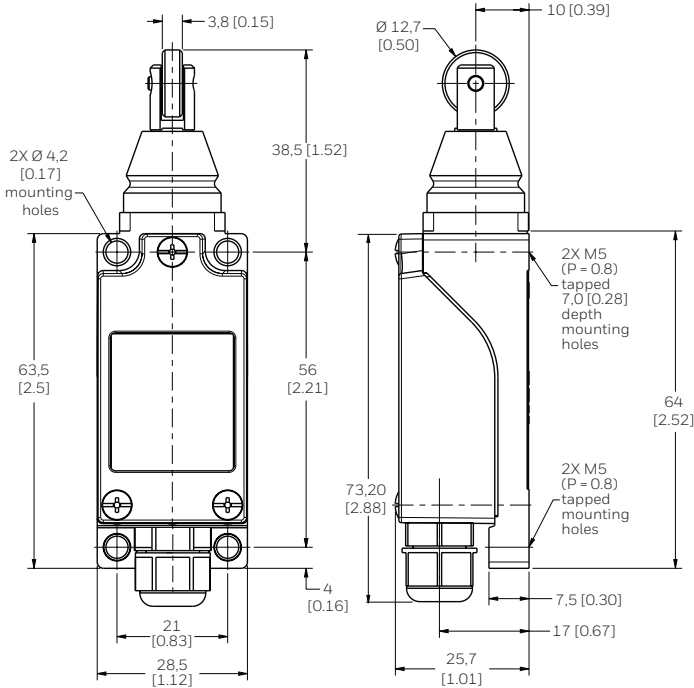

Figure 10. SZL-VL Roller Plunger Limit Switch

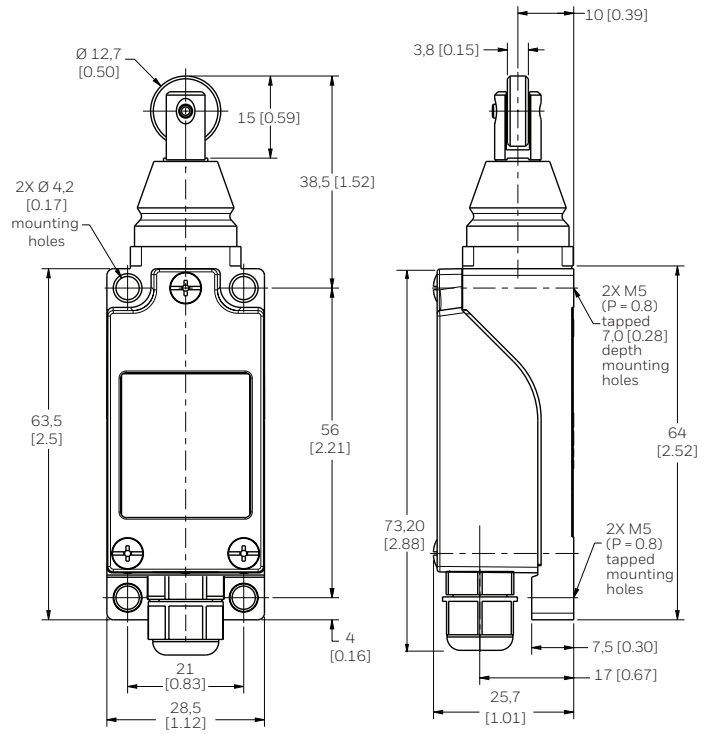

Figure 11. SZL-VL Coil Wobble (Plastic Tip) Limit Switch

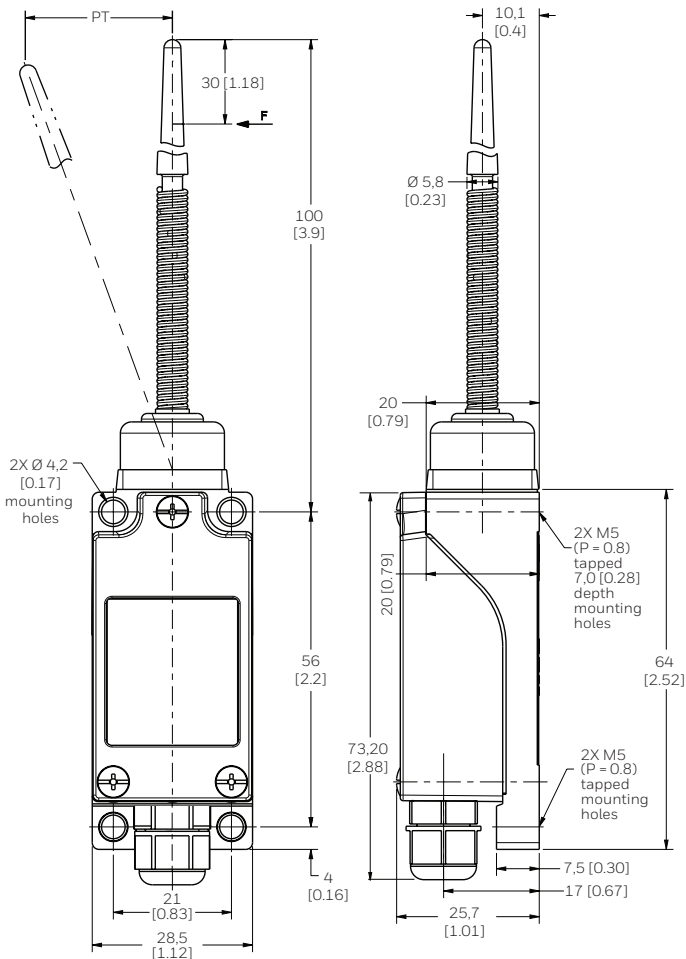
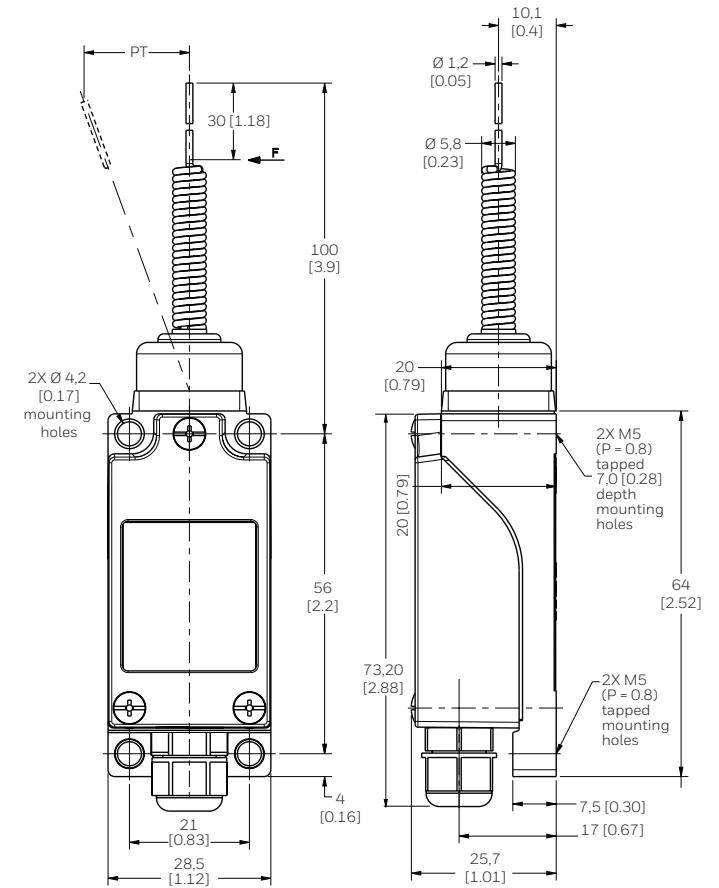

Figure 12. SZL-VL Coil Wobble (Wire Tip) Limit Switch



MICRO SWITCH Miniature Industrial Limit Switch, SZL-VL-S Series

Figure 13. SZL-VL Coil Wobble Limit Switch

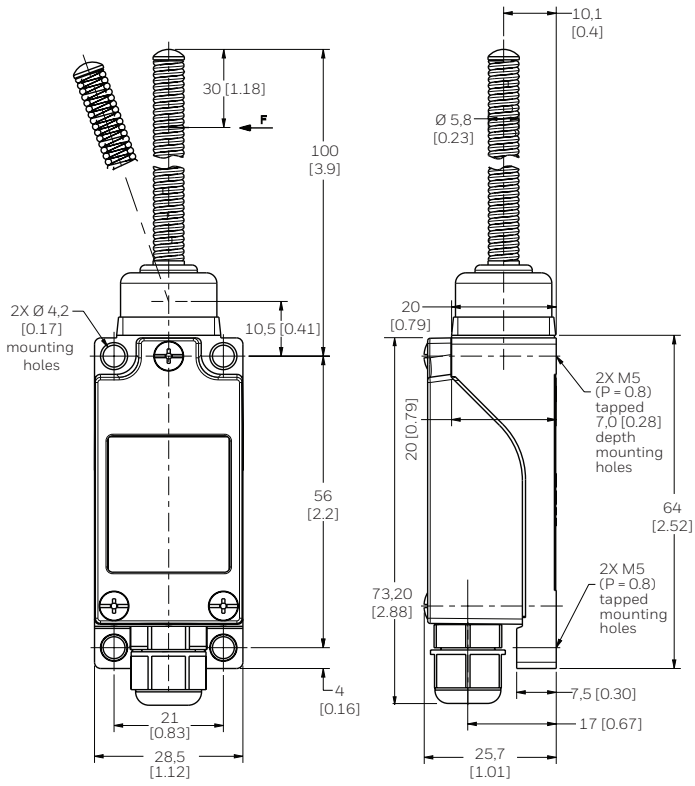
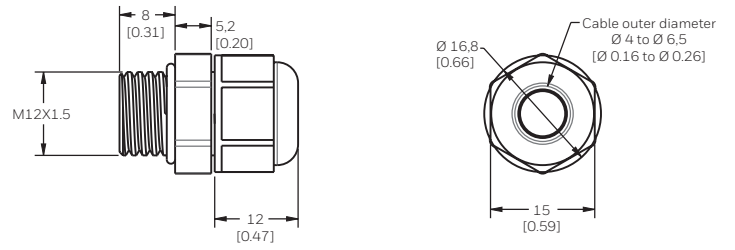

Figure 14. SZL-VL M12 Cable Gland (A1-LSC-F)



ADDITIONAL INFORMATION

The following associated literature is available on the Web at sensing.honeywell.com:

- Product installation instructions
- Product range guide
- Product application-specific information
 - Application Note: Mid-tier Limit Switch Product Introduction

WARNING **PERSONAL INJURY**

DO NOT USE these products as safety or emergency stop devices or in any other application where failure of the product could result in personal injury.

Failure to comply with these instructions could result in death or serious injury.

WARNING **MISUSE OF DOCUMENTATION**

- The information presented in this product sheet is for reference only. Do not use this document as a product installation guide.
- Complete installation, operation, and maintenance information is provided in the instructions supplied with each product.

Failure to comply with these instructions could result in death or serious injury.

Find out more

Honeywell serves its customers through a worldwide network of sales offices and distributors.

For application assistance, current specifications, pricing or name of the nearest Authorized Distributor, contact your local sales office.

To learn more about Honeywell's sensing and switching products, call **+1-815-235-6847** or

1-800-537-6945,

visit **sensing.honeywell.com**, or

e-mail inquiries to

info.sc@honeywell.com

Warranty/Remedy

Honeywell warrants goods of its manufacture as being free of defective materials and faulty workmanship during the applicable warranty period. Honeywell's standard product warranty applies unless agreed to otherwise by Honeywell in writing; please refer to your order acknowledgement or consult your local sales office for specific warranty details. If warranted goods are returned to Honeywell during the period of coverage, Honeywell will repair or replace, at its option, without charge those items that Honeywell, in its sole discretion, finds defective. **The foregoing is buyer's sole remedy and is in lieu of all other warranties, expressed or implied, including those of merchantability and fitness for a particular purpose. In no event shall Honeywell be liable for consequential, special, or indirect damages.**

While Honeywell may provide application assistance personally, through our literature and the Honeywell web site, it is buyer's sole responsibility to determine the suitability of the product in the application.

Specifications may change without notice. The information we supply is believed to be accurate and reliable as of this writing. However, Honeywell assumes no responsibility for its use.

Honeywell Sensing and Internet of Things

9680 Old Bailes Road
Fort Mill, SC 29707
honeywell.com

002389-3-EN IL50 GLO
May 2017

© 2017 Honeywell International Inc. All rights reserved.

Honeywell