



Chipsmall Limited consists of a professional team with an average of over 10 year of expertise in the distribution of electronic components. Based in Hongkong, we have already established firm and mutual-benefit business relationships with customers from,Europe,America and south Asia,supplying obsolete and hard-to-find components to meet their specific needs.

With the principle of “Quality Parts,Customers Priority,Honest Operation,and Considerate Service”,our business mainly focus on the distribution of electronic components. Line cards we deal with include Microchip,ALPS,ROHM,Xilinx,Pulse,ON,Everlight and Freescale. Main products comprise IC,Modules,Potentiometer,IC Socket,Relay,Connector.Our parts cover such applications as commercial,industrial, and automotives areas.

We are looking forward to setting up business relationship with you and hope to provide you with the best service and solution. Let us make a better world for our industry!



Contact us

Tel: +86-755-8981 8866 Fax: +86-755-8427 6832

Email & Skype: info@chipsmall.com Web: www.chipsmall.com

Address: A1208, Overseas Decoration Building, #122 Zhenhua RD., Futian, Shenzhen, China



LCD Module Technical Specification

液晶表示モジュール仕様書

First Edition 初版作成
Oct.24, 2008

Final Revision 最終改訂

Type No. **T-51750GD065J-LW-AON**

Customer : OPTREX STANDARD / オプトレックススタンダード

Customer's Product No : -----

OPTREX CORPORATION

Approved:

Checked:

Prepared:

APPROVED

By

Signature :

Date :

Please return this specification within two month with your signature.
If not returned within two month, specification will be considered
as having been accepted.

受領印ご押印の上、2008 年 12月 24日までに、弊社担当者までご返却ください。
ご返却なき場合は、問題ないものとして取り扱い処理させていただきます。

Table of Contents (目次)

1. Application (適用)	3
2. General Specifications (一般仕様)	3
3. Operating Conditions (環境条件)	4
4. Dimensional Outline (外形図)	5
5. Block Diagram (ブロック図)	6
6. I/O Terminal (I/O端子)	7
7. Electrical Specifications (電氣的仕様)	9
8. Optical Specifications (光学仕様)	18
9. Test (試験)	23
10. Appearance Standards (外觀規格)	25
11. Code System of Production Lot (製造ロット番号)	29
12. Type Number (製品型式)	29
13. Applying Precautions (運用上の注意)	29
14. Precautions Relating Product Handling (製品取扱い上の注意)	30
15. Warranty (保証条件)	33

Revision History (改訂来歴)

Rev.(改版)	Date(改定日)	Page(ページ)	Comment(内容)

T-51750GD065J-LW-AON	OPTREX CORPORATION	Page 2/33
----------------------	--------------------	-----------

1. Application (適用)

This specification applies to TFT-LCD module (T-51750GD065J-LW-AON).

本仕様書は、オプトレックス(株)が製造する TFT-LCD モジュール
(品番 : T-51750GD065J-LW-AON)に適用する。

2. General Specifications (一般仕様)

Resolution (画素数)	: 640 x 3 [R.G.B] (W) x 480 (H) dots
Dot pitch (ドットピッチ)	: 0.069 x 3 [R.G.B] (W) x 0.207 (V) mm
Pixel arrangement (画素配列)	: RGB-Stripe
Color depth (色数)	: 262,144 colors
Active Viewing Area (有効視野範囲)	: 132.5 (W) x 99.4 (H) mm
Outline dimensions * (外形寸法)	: 158.0 (W) x 120.36 (H) x 10.75 (D) mm * Excluding backlight cables.(バックライトケーブルを含まない)
Weight (重量)	: 230g Max.
LCD type (LCD タイプ)	: TFT / Normally white-mode / Transmissive (TFT / ノーマリーホワイト / 透過型)
Viewing angle (視角)	: 6:00
Surface Treatment (表面処理)	: AG Coating
Interface (データ転送方式)	: 18-bit RGB Interface (6-bit / color) (18 ビット RGB インターフェース (6 ビット / 色))
Backlight (照明仕様)	: LED Backlight / White (LED バックライト / 白色)
RoHS regulation (RoHS 規定)	: To our best knowledge, this product satisfies material requirement of RoHS regulation. Our company is doing the best efforts to obtain the equivalent certificate from our suppliers. : 当社の認知する限りにおいて、本製品は RoHS 規定の主要要件を満たしていると認識しております。 当社としては、部材メーカー等に対して同様の保証を求めべく最大限の努力を行っております。

3. Operating Conditions (環境条件)

Item (項目)	Conditions (条件)	Temperature Range (温度範囲)	Remark (備考)
Operating Temperature Range (動作温度範囲)	PNL Surface (パネル表面)	0~60°C	Note1 (注1)
Storage Temperature Range (保存温度範囲)	PNL Surface (パネル表面)	-20~70°C	

Note1: Operating temperature range defines the operation only and the contrast, response time and other display optical characteristics are set at Ta=+25°C.

注1: 動作温度範囲は、動作のみを保証する温度であり、コントラスト、応答速度、その他の表示品位、光学性能は Ta=+25°Cにて判定します。

4. Dimensional Outline (外形図)

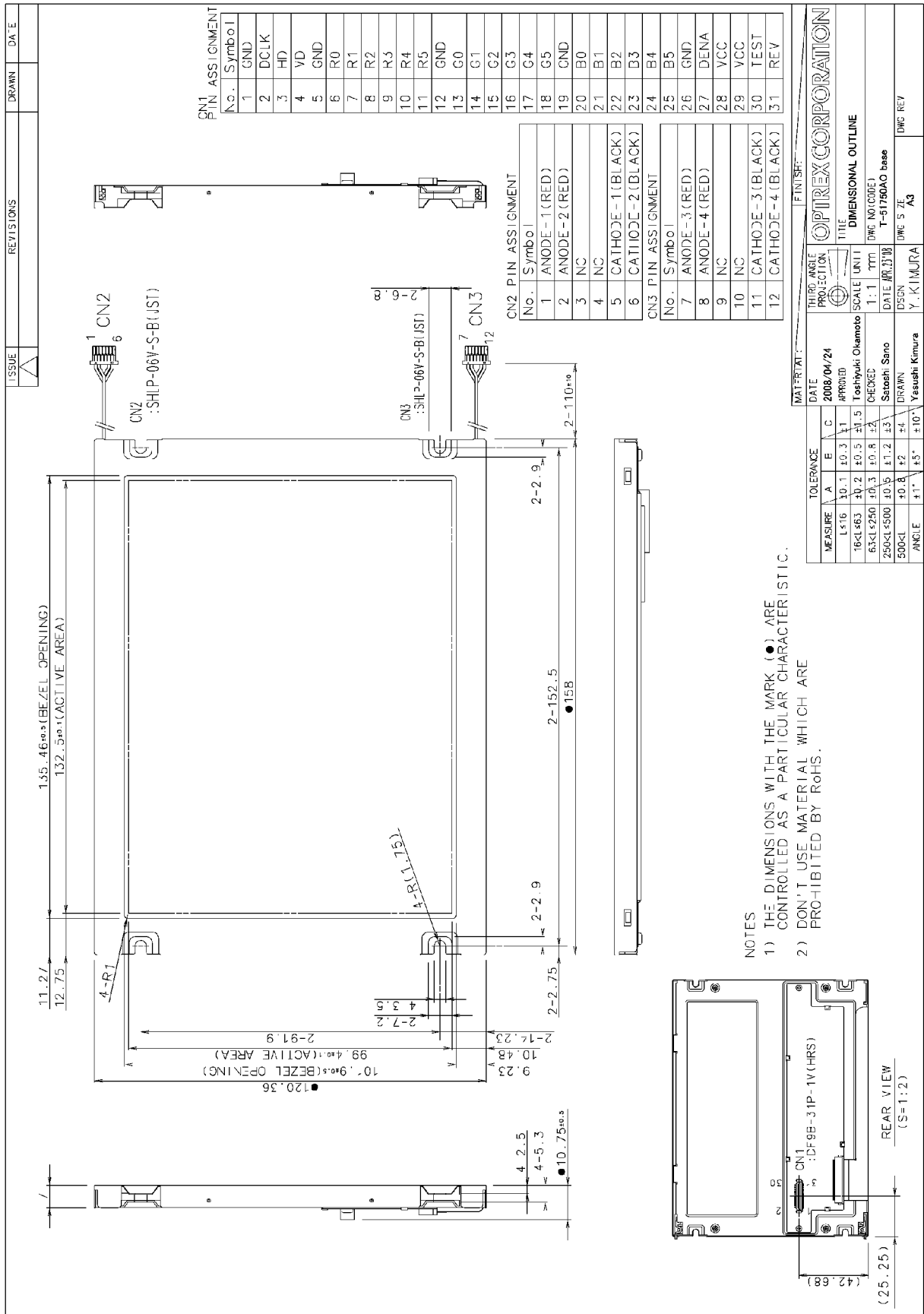

5. Block Diagram (ブロック図)

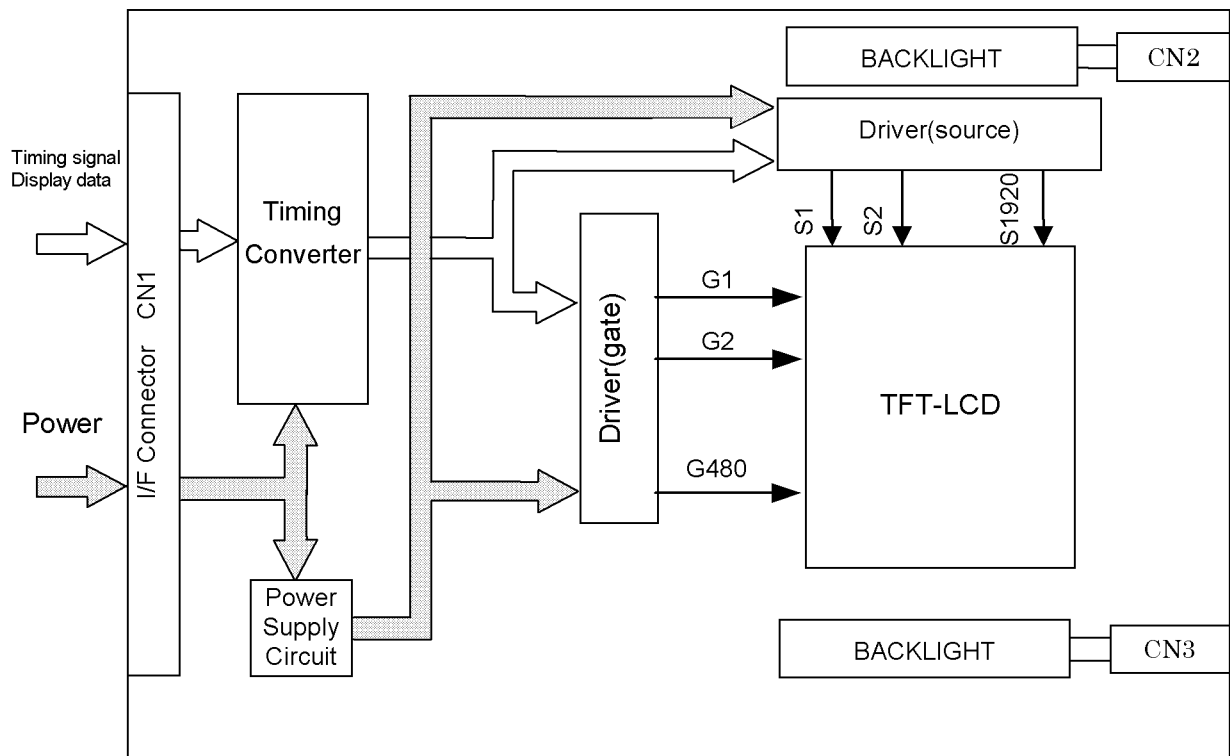

6. I/O Terminal (I / O 端子)

6.1. CN1 Pin Assignment (CN1 端子名)

INTERFACE SIGNAL (インターフェース信号)

Used connector(使用コネクタ): DF9B-31P-1V (HIROSE)

Corresponding connector(適合コネクタ): DF9B-31S-1V (HIROSE)

No.	Symbol(記号)	Functional Description (機能説明)
1	GND	Power Supply (0V, GND) (電源 (0V, GND))
2	DCLK	Clock signal for sampling catch data signal (クロック信号)
3	HD	Horizontal sync signal (水平同期信号)
4	VD	Vertical sync signal (垂直同期信号)
5	GND	Power Supply (0V, GND) (電源 (0V, GND))
6	R0	Red data signal(LSB) (赤データ信号)
7	R1	Red data signal (赤データ信号)
8	R2	Red data signal (赤データ信号)
9	R3	Red data signal (赤データ信号)
10	R4	Red data signal (赤データ信号)
11	R5	Red data signal(MSB) (赤データ信号)
12	GND	Power Supply (0V, GND) (電源 (0V, GND))
13	G0	Green data signal(LSB) (緑データ信号)
14	G1	Green data signal (緑データ信号)
15	G2	Green data signal (緑データ信号)
16	G3	Green data signal (緑データ信号)
17	G4	Green data signal (緑データ信号)
18	G5	Green data signal(MSB) (緑データ信号)
19	GND	Power Supply (0V, GND) (電源 (0V, GND))
20	B0	Blue data signal(LSB) (青データ信号)
21	B1	Blue data signal (青データ信号)
22	B2	Blue data signal (青データ信号)
23	B3	Blue data signal (青データ信号)
24	B4	Blue data signal (青データ信号)
25	B5	Blue data signal(MSB) (青データ信号)
26	GND	Power Supply (0V, GND) (電源 (0V, GND))
27	DENA	Data enable signal(to settle the viewing area) (データイネーブル (データ期間表示信号))
28	VCC	Power Supply (電源)(DC 3.3V or 5V)
29	VCC	Power Supply (電源)(DC 3.3V or 5V)
30	TEST	This pin should be open. Test signal output for only internal test use. (テスト信号出力端子 (システム側でオープンにしてください))
31	REV	Reverse scans control. L = Normal, H = Reverse (表示方向切換え。L=通常走査、H=逆走査)

Note(注): The shielding case is connected with GND (フレームは GND に接続されています。)

6.2.CN 2 Pin Assignment (CN2 端子名)

Used connector(使用コネクタ): SHLP-06V-S-B (JST)

Corresponding connector(適合コネクタ): SM06-SHLS-TF (JST)

No.	Symbol(記号)	Functional Description (機能説明)
1	ANODE-1(REDF)	LED Anode Terminal (LED アノード端子)
2	ANODE-2(REDF)	LED Anode Terminal (LED アノード端子)
3	NC	Non Connection (未使用端子)
4	NC	Non Connection (未使用端子)
5	CATHODE-1(BLACK)	LED Cathode Terminal (LED カソード端子)
6	CATHODE-2(BLACK)	LED Cathode Terminal (LED カソード端子)

6.3.CN 3 Pin Assignment (CN3 端子名)

Used connector(使用コネクタ): SHLP-06V-S-B(JST)

Corresponding connector(適合コネクタ): SM06-SHLS-TF(LF)(SN)(JST)

No.	Symbol(記号)	Functional Description (機能説明)
1	ANODE-3(REDF)	LED Anode Terminal (LED アノード端子)
2	ANODE-4(REDF)	LED Anode Terminal (LED アノード端子)
3	NC	Non Connection (未使用端子)
4	NC	Non Connection (未使用端子)
5	CATHODE-3(BLACK)	LED Cathode Terminal (LED カソード端子)
6	CATHODE-4(BLACK)	LED Cathode Terminal (LED カソード端子)

7. Electrical Specifications (電氣的仕様)

7.1. Absolute Maximum Ratings (絶対最大定格)

Ta=0~60°C, GND=0V

Parameter (項目)	Symbol (記号)	Conditions (条件)	Min.	Max.	Units (単位)
Supply Voltage for LCD	VCC	-	0	5.5	V
Logic Input Voltage	VI	-	-0.3	5.5	V

7.2. DC Characteristics (DC特性)

Ta=0~60°C, GND=0V

Parameter (項目)	Symbol (記号)	Conditions (条件)	Min.	Typ.	Max.	Units (単位)	
Power Supply Voltages for LCD (LCD電源電圧) Note A)	VCC	for 3.3V system (3.3V系駆動時)	3.0	3.3	3.6	V	
		for 5V system (5V系駆動時)	4.5	5.0	5.5	V	
Power Supply Currents for LCD (LCD電源電流) Note B)	ICC	for 3.3V system (3.3V系駆動時)	--	240	--	mA	
		for 5V system (5V系駆動時)	--	180	--	mA	
Permissive input ripple Voltage (許容リップル電圧)	VRP	VCC=+3.3V	--	--	100	mVp-p	
		VCC=+5.0V	--	--	100	mVp-p	
Logic Input Voltage (ロジック入力電圧)	High	VCC=MAX	VIH	2.4	--	5.5	V
	Low	VCC=MIN	VIL	--	--	0.8	V

[Note]

A) VCC-dip conditions:(電源・信号シーケンス)

- 1) When $2.4\text{ V} \leq \text{VCC} < 3.0\text{ V}$ or 4.5V , $t_d \leq 10\text{ ms}$
- 2) When $\text{VCC} < 2.4\text{ V}$

VCC-dip conditions should also follow the power and signals sequence.

(VCC - dipの条件は電源・信号シーケンスに従います。)

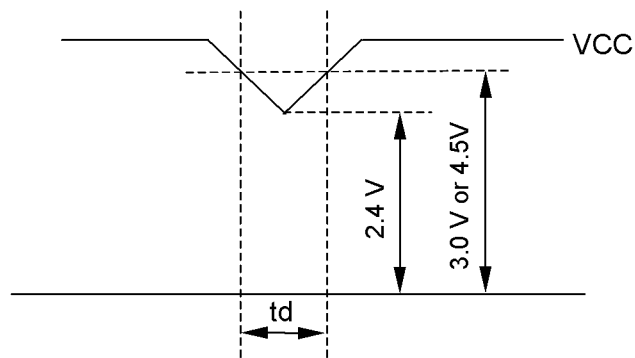

B) Typical current condition(標準電流条件):

64- gray- bar-pattern (0~63階調の横階調パターン)

480 line mode (480ラインモード)

VCC = +3.3 V, $f_H=31.5\text{kHz}$, $f_V=60\text{Hz}$, $f_{\text{CLK}}= 25\text{MHz}$

VCC = +5.0 V, $f_H=31.5\text{kHz}$, $f_V=60\text{Hz}$, $f_{\text{CLK}}= 25\text{MHz}$

7.3.AC Characteristic (AC 特性)

	Parameter (項目)	Symbol (記号)	Min.	Typ.	Max.	Units (単位)
DCLK	Frequency (周波数)	f_{CLK}	20	25	30	MHz
	Period (周期)	t_{CLK}	33.3	40	50	ns
	Low Width (パルス幅(Low))	t_{WCL}	10	--	--	ns
	High Width (パルス幅(High))	t_{WCH}	10	--	--	ns
DATA (R,G,B,DENA, HD, VD)	Set up time (セットアップ時間)	t_{DS}	5	--	--	ns
	Hold time (保持時間)	t_{DH}	5	--	--	ns
DENA	Horizontal Active Time (水平表示時間)	t_{HA}	640	640	640	t_{CLK}
	Horizontal Front Porch (水平フロントポーチ)	t_{HFP}	0	--	--	t_{CLK}
	Horizontal Back Porch (水平バックポーチ)	t_{HBP}	7	--	--	t_{CLK}
	Vertical Active Time (垂直表示時間)	t_{VA}	480	480	480	t_H
	Vertical Front Porch (垂直フロントポーチ)	t_{VFP}	1	20	--	t_H
	Vertical Back Porch (垂直バックポーチ)	t_{VBP}	8	20	--	t_H
HD	Frequency (周波数)	f_H	27	31.5	38	kHz
	Period (周期)	t_H	26.3	31.7	37.0	μs
	Low Width (パルス幅(Low))	t_{WHL}	5	--	--	t_{CLK}
VD	Frequency (周波数)	f_V	55	60	70	Hz
	Period (周期)	t_V	14.3	16.7	18.2	ms
	Low Width (パルス幅(Low))	t_{WWL}	3	--	--	t_H

[Note](注)

- 1) DATA is latched at fall edge of DCLK in this timing specification.
(DATAはDCLKの立ち下がりエッジで取り込みます。)
- 2) Polarities of HD and VD are negative in this specification.
(HDとVDは負極性です。)
- 3) DENA (Data Enable) should always be positive polarity as shown in the timing specification.
(DENA(データイネーブル)は常に正極性です。)
- 4) DCLK should appear during all invalid period, and HD should appear during invalid period of frame cycle.
(DCLKは全ブランク期間にも入力が必要です。また、HDは垂直ブランク期間にも入力が必要です。)
- 5) Accepted only 640 data and 480 lines.
(640ドット、480ライン分のデータのみ対応です。)
- 6) REV should be stable during operation.
(REVは動作中に変更しないで下さい。)
- 7) Please consider the influence of the filter circuit which is placed in the Signal Input, DCLK and Data Bus, when designing the circuit. AC Characteristic spec is based on ideal signal driving.
(入力信号、DCLKおよびデータバス上のフィルタ回路の影響を考慮してタイミングを決定してください。AC特性は理想状態での駆動に基づいた仕様です。)

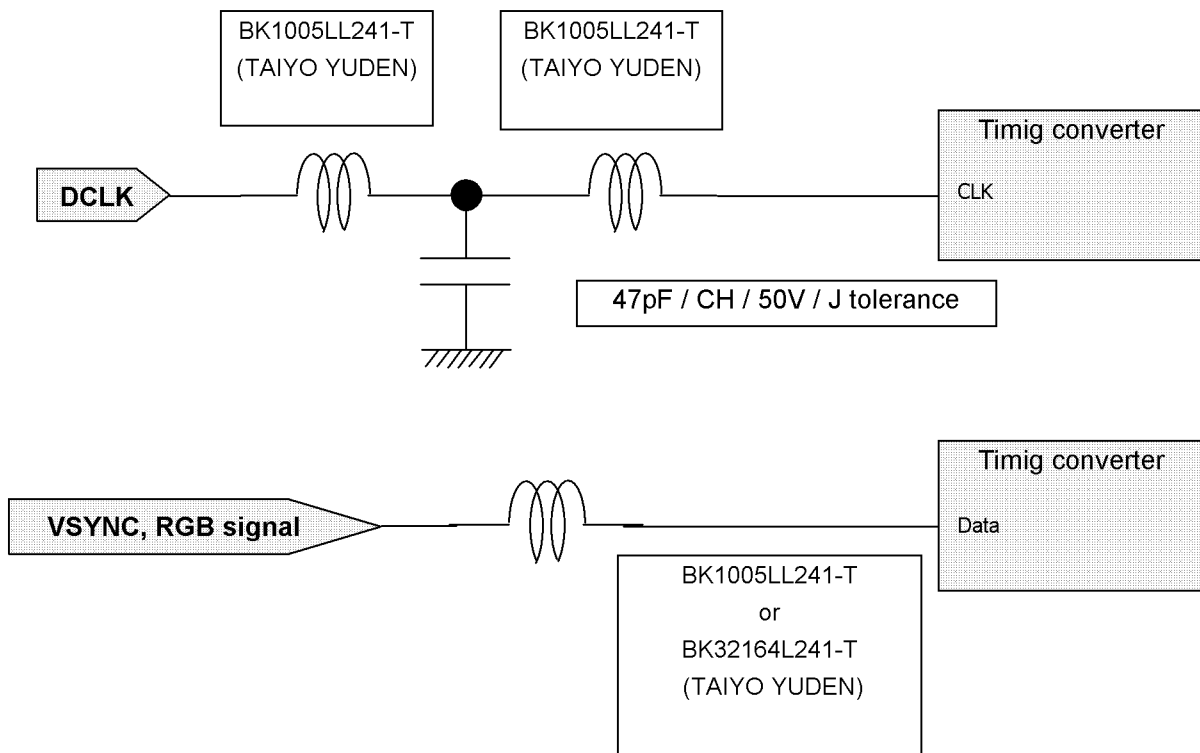

7.4. Timing Chart (タイミングチャート)

a. Pixel Timing Chart (ピクセルタイミングチャート)

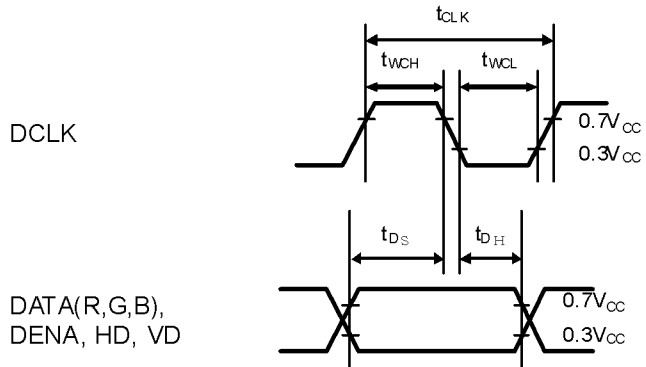

b. Horizontal Timing Chart (水平タイミングチャート)

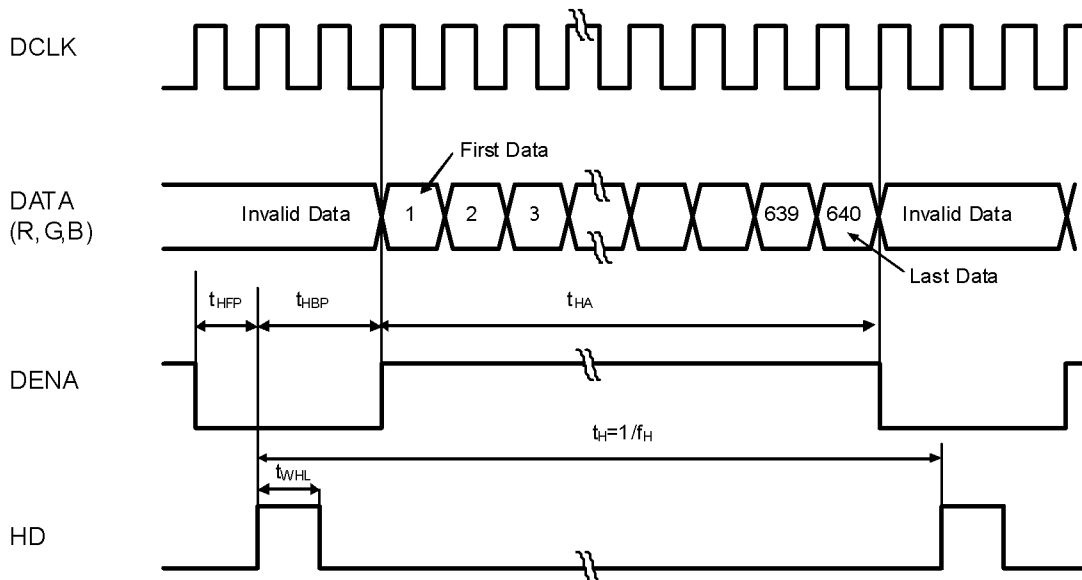

c. Vertical Timing Chart (垂直タイミングチャート)

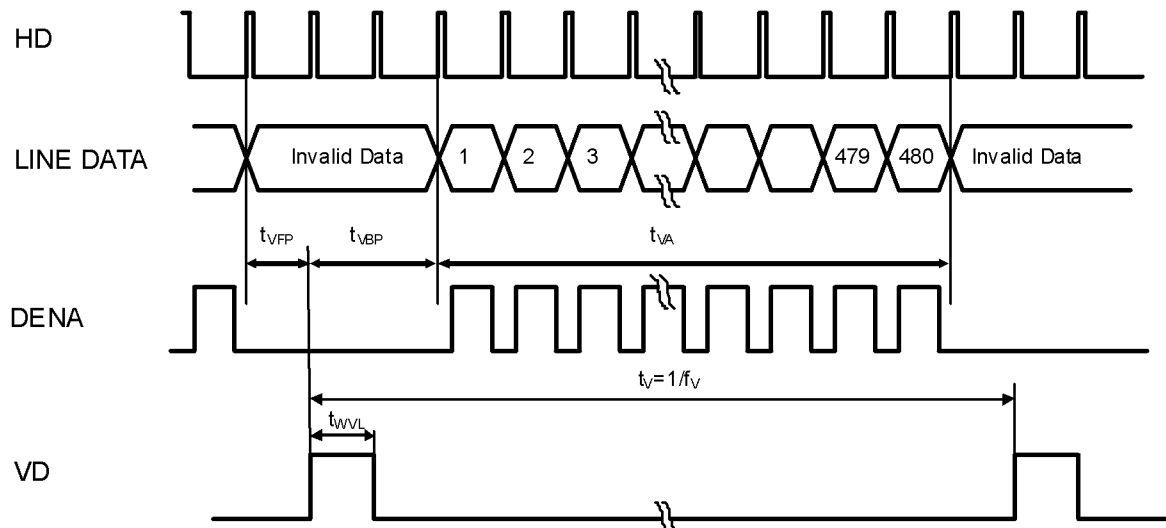

7.5. Power and signals sequence (電源及び信号シーケンス)

$t1 \leq 10 \text{ ms}$ $200 \text{ ms} < t6$
 $0 < t2 \leq 50 \text{ ms}$ $0 \leq t7$
 $0 < t3 \leq 50 \text{ ms}$
 $0 < t4 \leq 50 \text{ ms}$
 $500 \text{ ms} < t5$

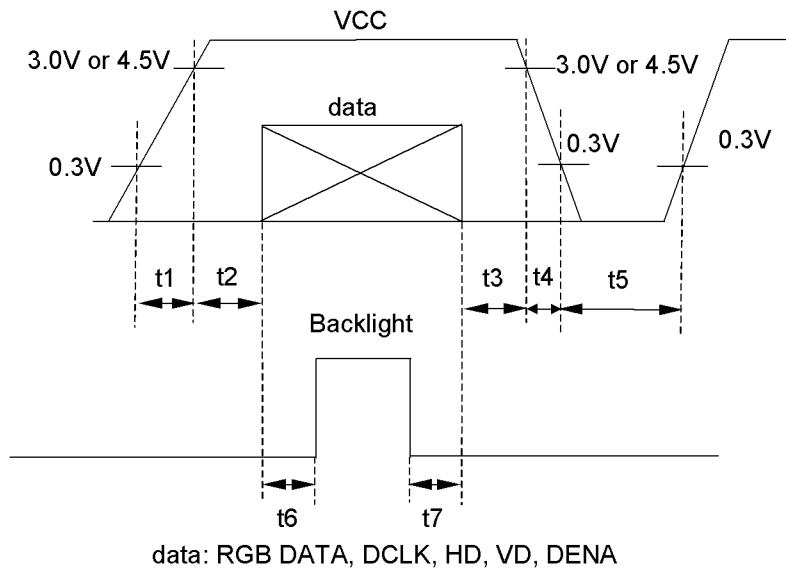

7.6. Pixel Alignment (画素配列)

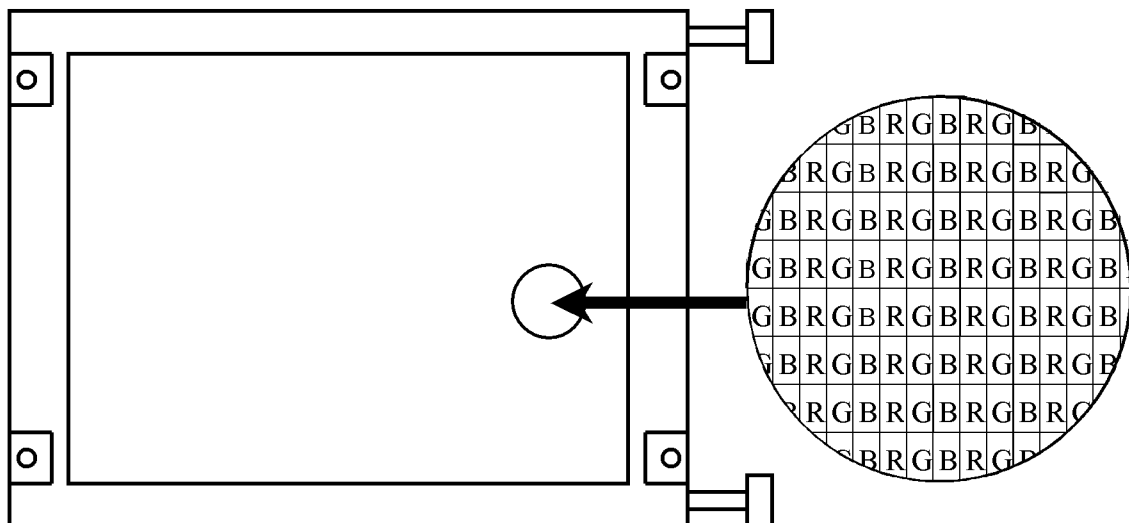

7.7.Color Data Assignment (カラーデータ設定表)

COLOR	INPUT DATA	R DATA						G DATA						B DATA					
		MSB			LSB			MSB			LSB			MSB			LSB		
		R5	R4	R3	R2	R1	R0	G5	G4	G3	G2	G1	G0	B5	B4	B3	B2	B1	B0
BASIC COLOR	BLACK	0	0	0	0	0	0	0	0	0	0	0	0	0	0	0	0	0	0
	RED (63)	1	1	1	1	1	1	0	0	0	0	0	0	0	0	0	0	0	0
	GREEN (63)	0	0	0	0	0	0	1	1	1	1	1	1	0	0	0	0	0	0
	BLUE (63)	0	0	0	0	0	0	0	0	0	0	0	0	1	1	1	1	1	1
	CYAN	0	0	0	0	0	0	1	1	1	1	1	1	1	1	1	1	1	1
	MAGENTA	1	1	1	1	1	1	0	0	0	0	0	0	1	1	1	1	1	1
	YELLOW	1	1	1	1	1	1	1	1	1	1	1	1	0	0	0	0	0	0
	WHITE	1	1	1	1	1	1	1	1	1	1	1	1	1	1	1	1	1	1
RED	RED (0)	0	0	0	0	0	0	0	0	0	0	0	0	0	0	0	0	0	0
	RED (1)	0	0	0	0	0	1	0	0	0	0	0	0	0	0	0	0	0	0
	RED (2)	0	0	0	0	1	0	0	0	0	0	0	0	0	0	0	0	0	0
	RED (62)	1	1	1	1	1	0	0	0	0	0	0	0	0	0	0	0	0	0
	RED (63)	1	1	1	1	1	1	0	0	0	0	0	0	0	0	0	0	0	0
GREEN	GREEN (0)	0	0	0	0	0	0	0	0	0	0	0	0	0	0	0	0	0	0
	GREEN (1)	0	0	0	0	0	0	0	0	0	0	0	1	0	0	0	0	0	0
	GREEN (2)	0	0	0	0	0	0	0	0	0	0	1	0	0	0	0	0	0	0
	GREEN (62)	0	0	0	0	0	0	1	1	1	1	1	0	0	0	0	0	0	0
	GREEN (63)	0	0	0	0	0	0	1	1	1	1	1	1	0	0	0	0	0	0
BLUE	BLUE (0)	0	0	0	0	0	0	0	0	0	0	0	0	0	0	0	0	0	0
	BLUE (1)	0	0	0	0	0	0	0	0	0	0	0	0	0	0	0	0	0	1
	BLUE (2)	0	0	0	0	0	0	0	0	0	0	0	0	0	0	0	0	1	0
	BLUE (62)	0	0	0	0	0	0	0	0	0	0	0	0	1	1	1	1	1	0
	BLUE (63)	0	0	0	0	0	0	0	0	0	0	0	0	1	1	1	1	1	1

[Note] (注)

1) Definition of gray scale (階調定義)

Color (n) --- n indicates gray scale level. (nは階調レベルを示します。)

Higher n means brighter level. (より高いnはより明るいレベルを意味します。)

2) Data 1:High, 0: Low

7.8. Inverted Scan Capability (スキャン反転機能)

This module has the capability of inverting scan direction by signaling from controller.

Note: Scan direction cannot be changed during operation.

(このモジュールには、コントローラから信号により走査方向を逆にすることができます。)

(注：スキャン方向の動作中の変更はできません。)

The following figure shows the relation between the display position and the scan direction.

(以下の図は、視認方向とスキャン方向の関係を表します。)

Normal scan(通常スキャン): REV = "L"

D(1, 1)	D(2, 1)	---	D(X, 1)	---	D(639, 1)	D(640, 1)
D(1, 2)	D(2, 2)	---	D(X, 2)	---	D(639, 2)	D(640, 2)
↓	↓	+	+	+	↓	↓
D(1, Y)	D(2, Y)	---	D(X, Y)	---	D(639, Y)	D(640, Y)
↓	↓	+	+	+	↓	↓
D(1,479)	D(2,479)	---	D(X,479)	---	D(639,479)	D(640,479)
D(1,480)	D(2,480)	---	D(X,480)	---	D(639,480)	D(640,480)

Reverse scan(反転スキャン): REV = "H"

D(640,480)	D(639,480)	---	D(X,480)	---	D(2,480)	D(1,480)
D(640,479)	D(639,479)	---	D(X,479)	---	D(2,479)	D(1,479)
↓	↓	+	+	+	↓	↓
D(640, Y)	D(639, Y)	---	D(X, Y)	---	D(2, Y)	D(1, Y)
↓	↓	+	+	+	↓	↓
D(640, 2)	D(639, 2)	---	D(X, 2)	---	D(2, 2)	D(1, 2)
D(640, 1)	D(639, 1)	---	D(X, 1)	---	D(2, 1)	D(1, 1)

The following drawing shows the relationship between the viewing direction and the scan direction.

(次の図は、見る方向と走査方向の関係を示します。)

Normal scan (通常スキャン)

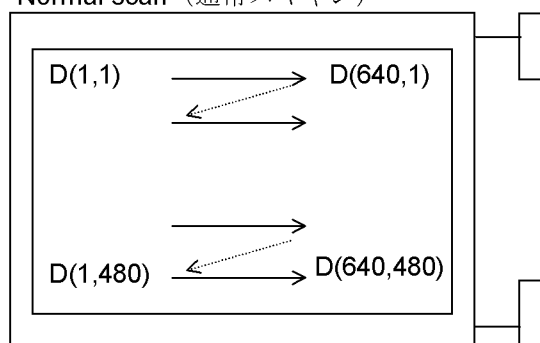

Reverse scan (反転スキャン)

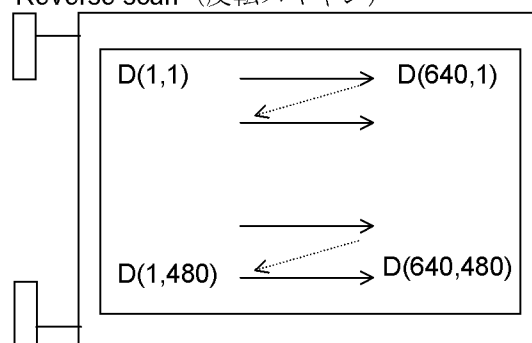

7.9.Lighting Specifications (照明仕様)

7.9.1.Absolute Maximum Ratings (絶対最大定格)

Ta=25°C

Parameter(項目)	Symbol(記号)	Conditions(条件)	Min.	Typ.	Max.	Units(単位)
Forward Current (順電流)	I _F	Note 2	-	-	40	mA
Allowable Reverse Current	I _R	-	-	-	85	mA
LED Power Dissipation (許容損失)	P _D	-	-	-	1.28	W

Note 1 : This value is for each 1 line.

(注1 : 1列あたりの値を示します。)

Note 2 : Refer to the forward current derating curve.

(注2 : ディレーティングカーブを下図に示す。)

【Forward Current Derating Curve (電流軽減特性)】

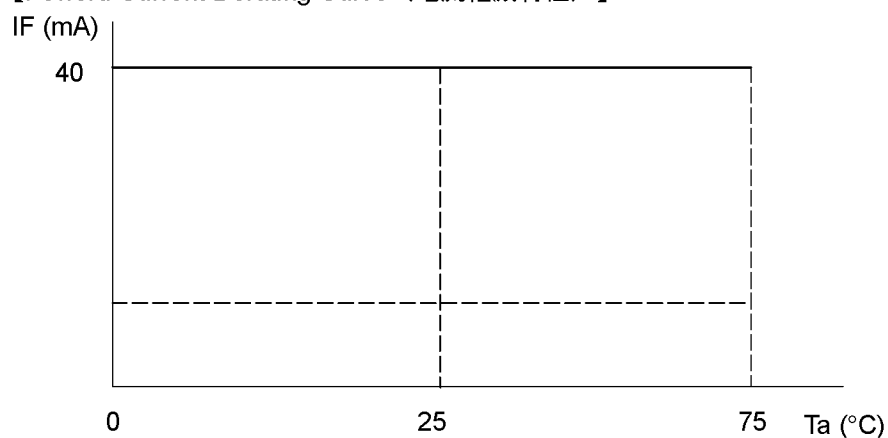

【LED Circuit (LED 回路)】

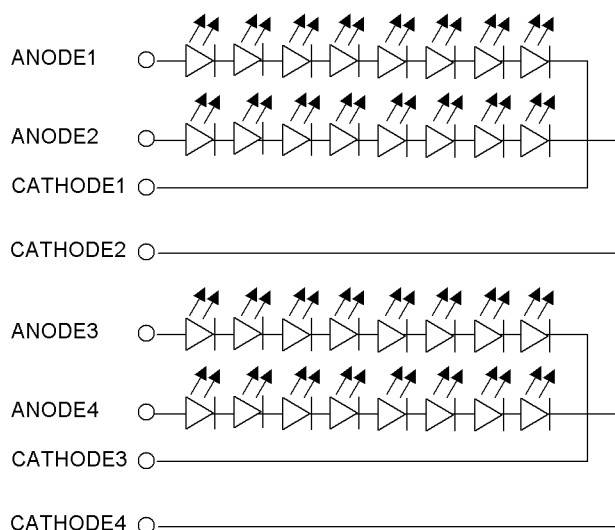

7.9.2.Operating Characteristics (動作定格)

Ta=25°C

Parameter(項目)	Symbol(記号)	Conditions(条件)	Min.	Typ.	Max.	Units(単位)
Forward Voltage V _F (順電圧)	V _F	-	-	28.8	32	V

8. Optical Specifications (光学仕様)

8.1. Optical Characteristic (光学特性)

Item (項目)	Symbol (記号)	Conditions(条件)			Standard Value(規格値)			Unit (単位)	Method of Measure (測定法)	Remark (備考)	
		θ	ϕ	C	Min.	Typ.	Max.				
(1) Brightness(輝度)	B	0°	0°	/	-	750		Cd/m ²	(Fig.1)	Note1	
(2) Contrast(コントラスト)	CR	Optimum Viewing Angle 最適視角での値			150	300	-	-			
(3) Color Coordinates (色度)	Red	Rx	0°	0°	/	-	0.55	-		-	
		Ry	0°	0°	/	-	0.35	-		-	
	Green	Gx	0°	0°	/	-	0.37	-		-	
		Gy	0°	0°	/	-	0.56	-		-	
	Blue	Bx	0°	0°	/	-	0.15	-		-	
		By	0°	0°	/	-	0.14	-		-	
	White	Wx	0°	0°	/	-	0.32	-	-		
Wy		0°	0°	/	-	0.35	-	-			
(4) Brightness Uniformity (輝度ムラ)	-	0°	0°	/	0.7	-	-	-	(Fig.2)		
(5) Vertical Viewing Angle (垂直視野角)	Up	θ_U	-	0°	≥ 10	-	30	-	Degree	(Fig.3)	
	Down	θ_D	-	0°	≥ 10	-	60	-	Degree		
(6) Horizontal Viewing Angle (水平視野角)	Left	ϕ_L	0°	-	≥ 10	-	55	-	Degree		
	Right	ϕ_R	0°	-	≥ 10	-	55	-	Degree		
(7) Response Time(応答時間)	Rise	τ_r	0°	0°	/	-	15	-	ms	(Fig.4)	
	Decay	τ_d	0°	0°	/	-	16	-	ms		
(8) Haze(ヘイズ)	H	/			-	9	-	%			

Note1: Under the condition of IF = 35mA/chip, Ta = 25°C

- ◆ Conditions for Measuring
 - ◇ Environment: Dark room with no light or close to no light.
 - ◇ Temperature: 25±5°C
 - ◇ Humidity: 40~70%RH
- ◆ 測定条件は下記の通り
 - ◇ 測定環境：暗室またはそれに準じる環境
 - ◇ 測定温度：25 ± 5°C
 - ◇ 測定湿度：40 ~ 70%RH
- ◆ Optimal viewing angle (The angle with best contrast)
- ◆ 主視角方向 (コントラストが最大となる方向)

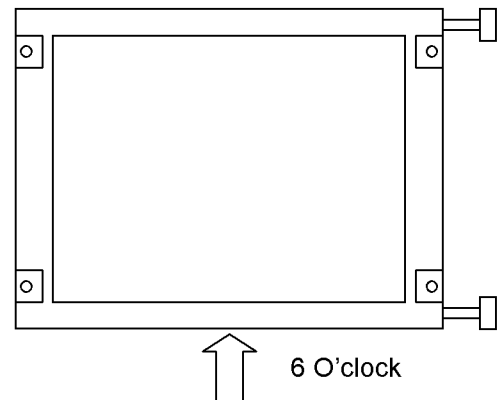

◆ Method of Brightness Measurement (輝度測定法) (Fig.1)

(1) Measuring Device (測定装置)

TOPCON BM-5, Measuring Field: 1°

(2) Measuring Point (測定点)

Center of Display $\theta=0^\circ, \phi=0^\circ$

On condition θ : A vertical angle from measuring direction to perpendicular.

ϕ : A horizontal angle from measuring direction to perpendicular.

画面中央部 $\theta = 0^\circ$ 、 $\phi = 0^\circ$

ただし、 θ : 法線に対する視角面の垂直軸方向の角度

ϕ : 法線に対する視角面の水平軸方向の角度

(3) Method of Measuring (測定方法)

Apply signal voltage (displayed in white) to maximize brightness and measure brightness B (cd/m^2).

The distance between BM-5's front lens to surface panel is 500mm.

Measured after backlight has been lit for more than 30 minutes.

輝度が最大となる信号電圧 (白表示) を印加し、輝度 B (cd/m^2) を測定する。

測定距離はBM-5 レンズ前面よりパネル表面まで500mmとして測定する。

バックライト点灯30分以上経過後に測定する。

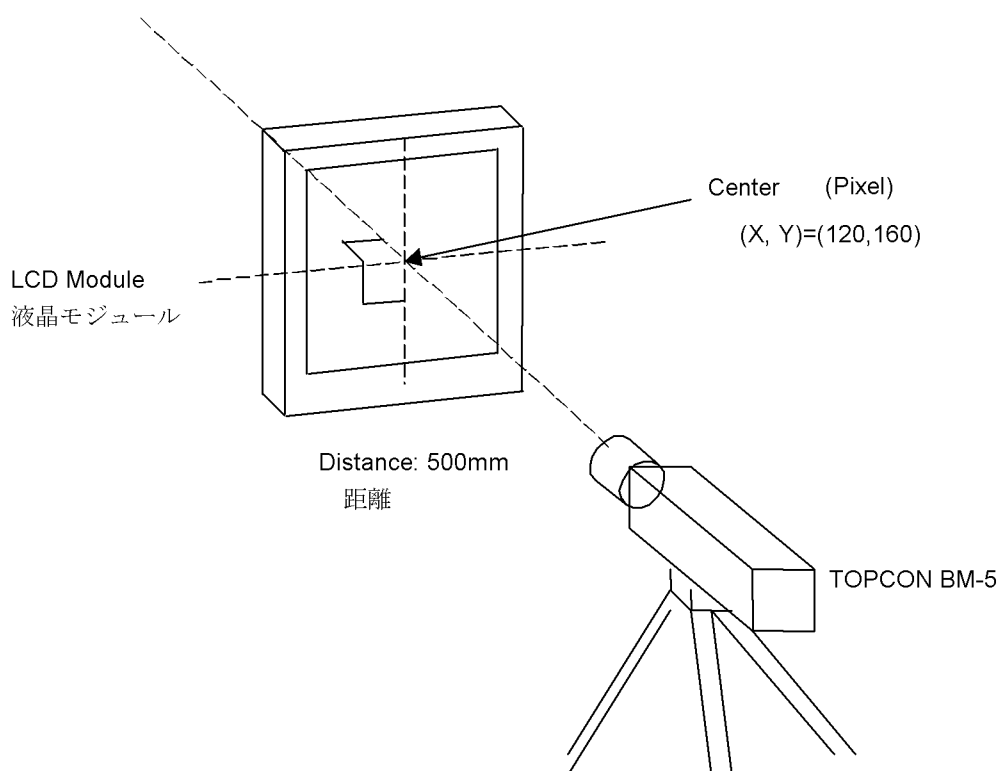

Fig. 1

◆ Method of Contrast Measurement (コントラスト測定法) (Fig.1)

(1) Measuring Device (測定装置)

TOPCON BM-5, Measuring Field: 1°

(2) Measuring Point (測定点)

Center of display: same as Method of Brightness Measurement

画面中央部：輝度測定点と同様

(3) Method of Measuring (測定方法)

• Set LCD module to $\theta=0^\circ, \phi=0^\circ$.

(液晶表示モジュールを $\theta = 0^\circ$ 、 $\phi = 0^\circ$ にセットする。)

• Change signal voltage to measure maximum brightness Y1 and minimum brightness Y2.

(信号電圧を変化させ、最大輝度 Y 1、最小輝度 Y 2 を測定する。)

• Contrast is derived from $CR=Y1/Y2$.

($CR = Y 1 / Y 2$ をコントラストとする。)

◆ Definition of Brightness Uniformity (輝度むらの定義) (Fig.2)

Definition is calculated from the 5 points (S0-S4) on the diagram below.

下図に示す点 (S 0 ~ S 4) の測定点で、下記の計算式にて定義する。

$$\text{Standard value of Brightness Uniformity}[\%] = \frac{\text{S0~S4 MIN (最小値)}}{\text{S0~S4 MAX (最大値)}} \times 100$$

(輝度むらの規格値)

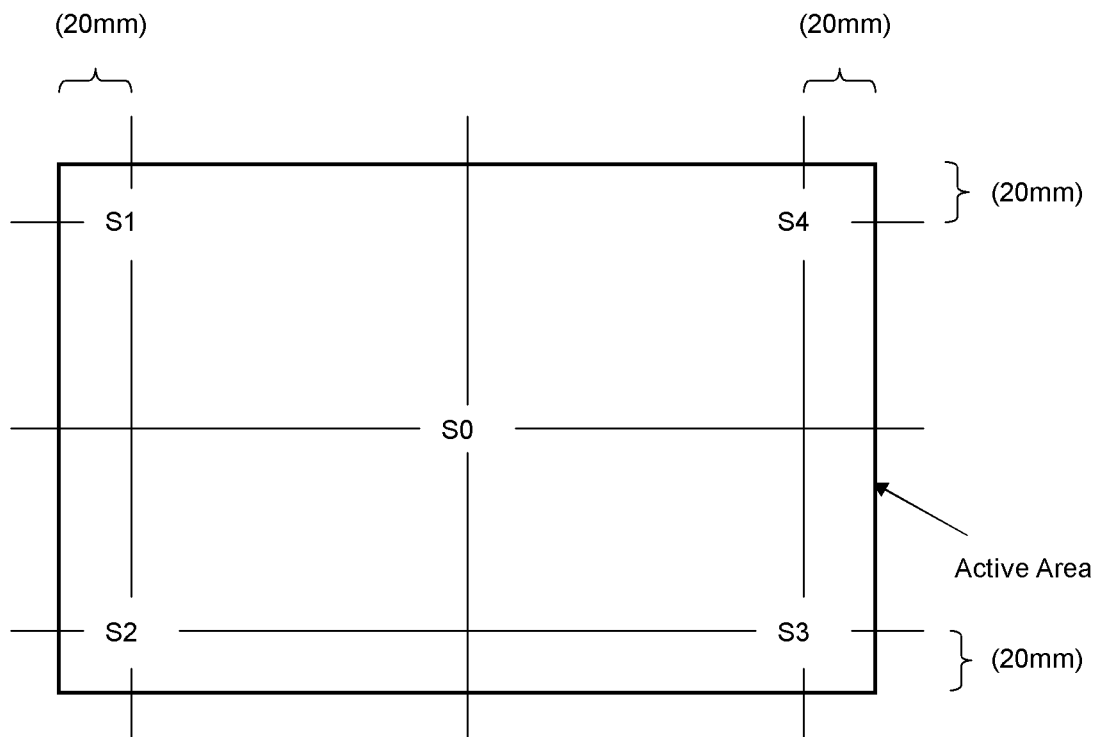

Fig. 2

◆ Method of Viewing Angle Measurement (視野角測定法) (Fig.3)

(1) Measuring Device (測定装置)

TOPCON BM-5, Measuring Field: 1°

(2) Measuring Point (測定点)

Center of display: Same as Method of Brightness Measurement

画面中央部：輝度測定点と同様

(3) Angle of Measuring (測定角度)

θ : An angle vertical to perpendicular line from the viewing direction.

θ : 法線に対する視角面の垂直軸方向の角度

ϕ : An angle horizontal to perpendicular from the viewing direction.

ϕ : 法線に対する視角面の水平軸方向の角度

(4) Method of Measuring (測定方法)

Set rotation table to $\phi=0^\circ$ and set BM-5 to contrast 10 to measure angle $\pm\theta$ for left and right direction of horizontal viewing angle ϕ . Also set rotation table to $\phi=90^\circ$ and set BM-5 to contrast 10 to measure angle $\pm\theta$ for up and down direction of vertical viewing angle θ .

回転ステージの $\phi = 0^\circ$ に固定してBM-7がコントラスト10となる $\pm\theta$ 角度を読み取り左右方向の水平視野角 ϕ 、回転ステージの $\phi = 90^\circ$ に固定してBM-7がコントラスト10となる $\pm\theta$ 角度を読み取り上下方向の垂直視野角 θ として記録する。

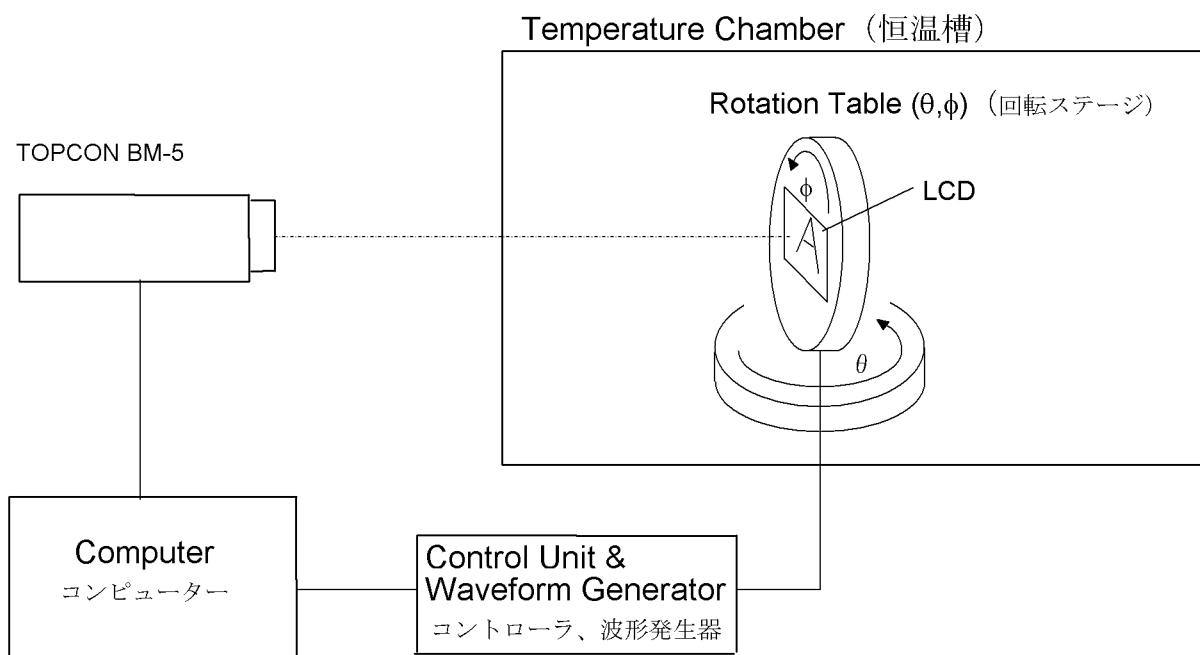

Fig. 3

◆ Measuring Response Time (応答時間の測定) (Fig.4)

(1) Measuring Device (測定装置)

TOPCON BM-5 , Measuring Field: 1°

Tektronix Digital Oscilloscope

テクトロニクス社製 デジタルオシロスコープ

(2) Measuring Point (測定点)

Center of display, same as Method of Brightness Measurement

画面中央部：輝度測定点と同様

(3) Method of Measuring (測定方法)

- Set LCD panel to $\theta=0^\circ$, and $\phi=0^\circ$.

液晶表示パネルを $\theta = 0^\circ$ 、 $\phi = 0^\circ$ にセットする。

- Input white→black→white to display by switching signal voltage.

白→黒→白と表示するように表示信号電圧を切り替えて印加する。

- If the luminance is 0% and 100% immediately before the change of signal voltage, then τ_r is optical response time during the change from 90% to 10% immediately after rise of signal voltage, and τ_d is optical response time during the change from 10% to 90% immediately after decay of signal voltage.

信号電圧切り替え直前の輝度をそれぞれ0%、100%とすると、表示信号立ち上り後、光学応答が90%から10%に変化するのにかかる時間を τ_r とし、表示信号立ち下がり後、光学応答が10%から90%にまで変化する時間を τ_d とする。

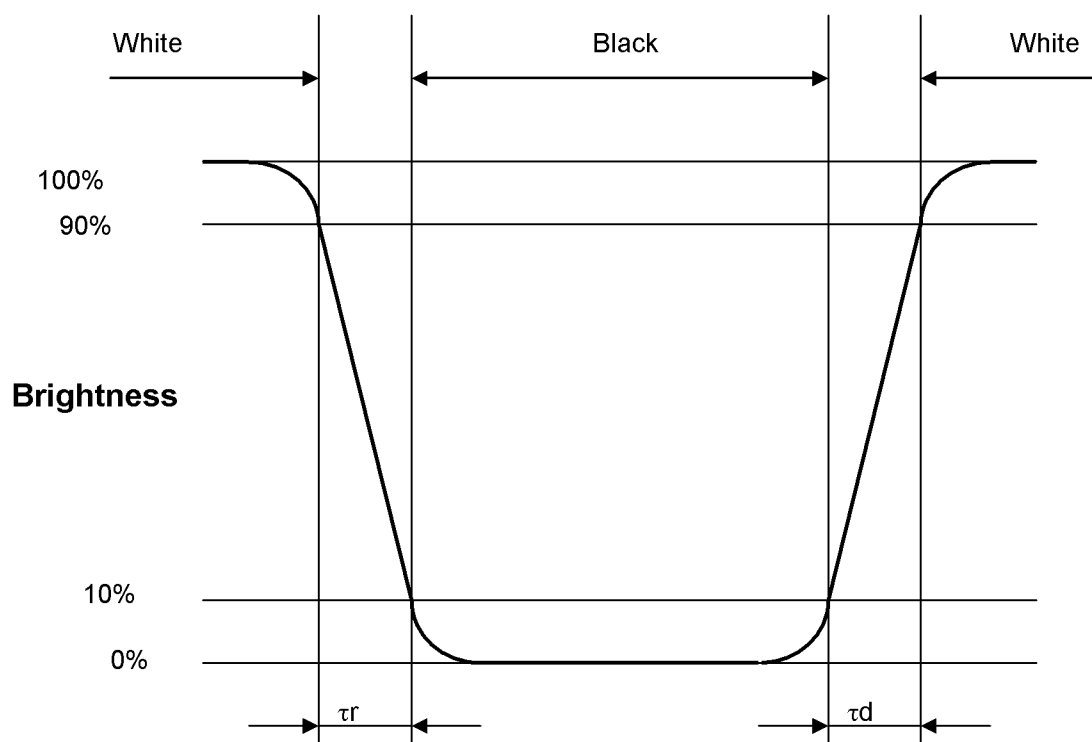

Fig. 4

9. Test (試験)

No abnormal function and appearance are found after the following tests.

下記の試験を実施した後、表示及び動作に異常がないこと。

Conditions: Unless otherwise specified, tests will be conducted under the following condition.

Temperature: 20±5°C

Humidity : 65±5%RH

tests will be not conducted under functioning state.

条件：特に指定の無い限り、温度 20±5°C、湿度 65±5%、無通電状態で行う。

No.	Parameter(項目)	Conditions(試験内容)	Notes(注記)
1	High Temperature Operating (高温動作試験)	60°C±2°C, 96hrs (operation state) (通電)	
2	Low Temperature Operating (低温動作試験)	0°C±2°C, 96hrs (operation state) (通電)	1
3	High Temperature Storage (高温保存試験)	70°C±2°C, 96hrs	2
4	Low Temperature Storage (低温保存試験)	-20°C±2°C, 96hrs	1,2
5	Damp Proof Test (耐湿試験)	40°C±2°C, 90~95%RH, 96hrs	1,2
6	Vibration Test (振動試験)	Frequency:10-57Hz/Vibration width(one side):0.75mm :58-500Hz/Gravity:9.8m/s ² Sweep time:11minutes Test period:3hrs for each direction of X,Y,Z 振動周波数 : 10~57Hz, 片振幅 : 0.075mm : 58-500Hz, 加速度 : 9.8m/s ² 掃引時間 : 11 分間 試験時間 3 時間, X,Y,Z 各方向 1 時間	3
7	Shock (衝撃)	Shock level:490m/s ² Waveform:half sinusoidal wave, 11ms Number of shocks : One shock input in each direction of three perpendicular axis for a total of six shock inputs 最高加速度 : 490m/s ² 正弦半波, t=11ms 回数 : 1 回 / 1 方向, ±X, ±Y, ±Z 各方向	

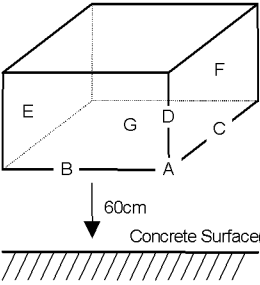
No.	Parameter(項目)	Conditions(試験内容)	Notes(注記)
9	Shock Test	<p>To be measured after dropping from 60cm high on the concrete surface in packing state. (正規の梱包状態にて 60cm の高さから下記の要領でコンクリート床へ落下)</p>  <p>Dropping method corner dropping(角落下) A corner : once(1回)</p> <p>Edge dropping(稜落下) B,C,D edge : once(1回)</p> <p>Face dropping(面落下) E,F,G face : once(1回)</p>	
<p>Note 1: No dew condensation to be observed. Note 2: The function test shall be conducted after 4 hours storage at the normal Temperature and humidity after removed from the test chamber. Note 3: Vibration test will be conducted to the product itself without putting it in a container. 注 1 : 結露しないこと。 注 2 : 試験後、常温常湿に 4 時間放置した後、測定する。 注 3 : 容器を用いずモジュール単品で行う。</p>			
T-51750GD065J-LW-AON		OPTREX CORPORATION	Page 24/33

10. Appearance Standards (外観規格)

10.1. Inspection conditions(外観検査条件)

The distance between the eyes and the sample shall be more than 30cm.
All directions for inspecting the sample should be within 45° against perpendicular line.
サンプルとの距離 30cm 以上で目視により検査を行う。
サンプルを目視する方向は、垂線に対して前後左右 45° の範囲内とする。

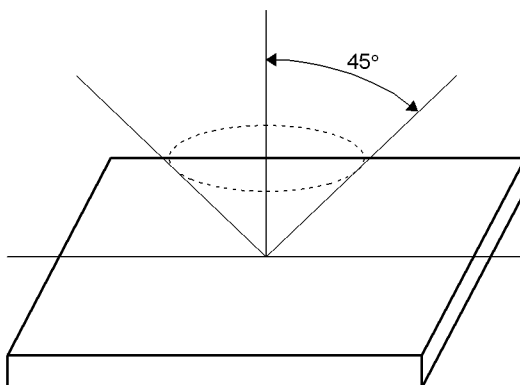

10.2. Definition of applicable Zones(サンプルの適用ゾーンの定義)

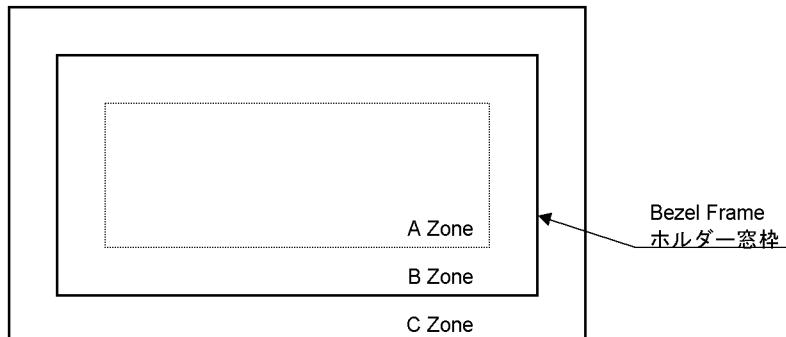

A Zone : Active display area
B Zone : Area from outside of "A Zone" to validity viewing area
C Zone : Rest parts

A Zone + B Zone = Validity viewing area

Aゾーン : ドット部
Bゾーン : ドットとホルダー窓枠に挟まれた部分
Cゾーン : その他の部分

Aゾーン+Bゾーン=有効視野範囲