



Chipsmall Limited consists of a professional team with an average of over 10 year of expertise in the distribution of electronic components. Based in Hongkong, we have already established firm and mutual-benefit business relationships with customers from,Europe,America and south Asia,supplying obsolete and hard-to-find components to meet their specific needs.

With the principle of "Quality Parts,Customers Priority,Honest Operation,and Considerate Service",our business mainly focus on the distribution of electronic components. Line cards we deal with include Microchip,ALPS,ROHM,Xilinx,Pulse,ON,Everlight and Freescale. Main products comprise IC,Modules,Potentiometer,IC Socket,Relay,Connector.Our parts cover such applications as commercial,industrial, and automotives areas.

We are looking forward to setting up business relationship with you and hope to provide you with the best service and solution. Let us make a better world for our industry!



Contact us

Tel: +86-755-8981 8866 Fax: +86-755-8427 6832

Email & Skype: info@chipsmall.com Web: www.chipsmall.com

Address: A1208, Overseas Decoration Building, #122 Zhenhua RD., Futian, Shenzhen, China



LCD Module Technical Specification

First Edition
Jan. 18, 2016

Final Revision
Mar. 10, 2016

Type No. **T-51750GD065J-LW-BHN**

Customer : **STANDARD**

Customer's Product No : -----

KYOCERA Display Corporation

Approved :



Checked :



Prepared :



APPROVED

By

Signature :

Date :

Please return this specification within two month with your signature.
If not returned within two month, specification will be considered
as having been accepted.

Table of Contents

- 1. Application 3
- 2. General Specifications 3
- 3. Operating Condition 3
- 4. Dimensional Outline 4
- 5. Block Diagram 5
- 6. Pin Assignment 6
- 7. Electrical Specifications 8
- 8. Optical Specifications 17
- 9. Test 22
- 10. Appearance Standards 23
- 11. Code System of Production Lot 28
- 12. Type Number 28
- 13. Applying Precautions 28
- 14. Precautions Relating Product Handling 29
- 15. Warranty 30

Revision History

Rev.	Date	Page	Comment
01	Mar. 10, 2016	8	7.2. DC characteristics (1) TFT-LCD Delete ()
		17	8. Optical Specifications Delete ()

1. Application

This specification applies to 6.5"color TFT-LCD module With touch panel (T-51750GD065J-LW-BHN).

2. General Specifications

Resolution	: 640 x 3 [R.G.B] (W) x 480 (H) dots
Dot pitch	: 0.069 x 3 [R.G.B] (W) x 0.207 (V) mm
Pixel arrangement	: RGB-Stripe
Color depth	: 262,144 colors
Active Viewing Area	: 132.5 (W) x 99.4 (H) mm
Outline dimensions *	: 158.0 (W) x 120.36 (H) x 12.15 (D) mm * Excluding backlight cables.
Weight	: 280 g max.
LCD type	: Normally white-mode / Transmissive
Viewing angle	: 6:00
Interface	: 18-bit parallel data transfer (6-bit / color)
Backlight	: LED Backlight / White
Surface Treatment	: AG Coating
Drawings	: Dimensional Outline T-51750BH base
RoHS regulation	: To our best knowledge, this product satisfies material requirement of RoHS regulation. Our company is doing the best efforts to obtain the equivalent certificate from our suppliers.

3. Operating Conditions

Item		Conditions	Temperature Range	Remark
Operating Temperature Range	LCD Module	Display Surface	-20~70°C	Note2-1
Storage Temperature Range	LCD Module	Display Surface	-20~70°C	Note2-2

Note2-1: Operating temperature range defines the operation only. Electrical and optical specification can be guaranteed at the condition that ambient temperature is 25°C.

Note2-2: Backlight is not activated.

5. Block Diagram

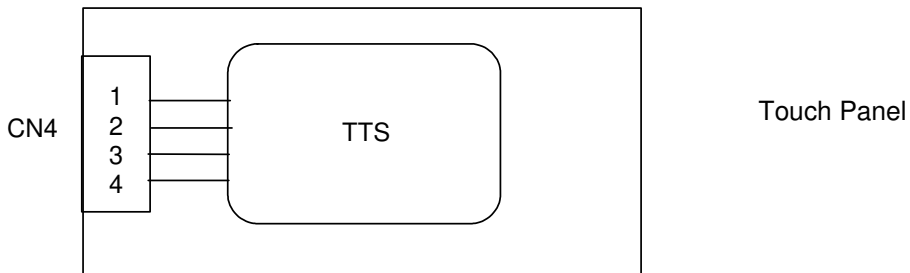
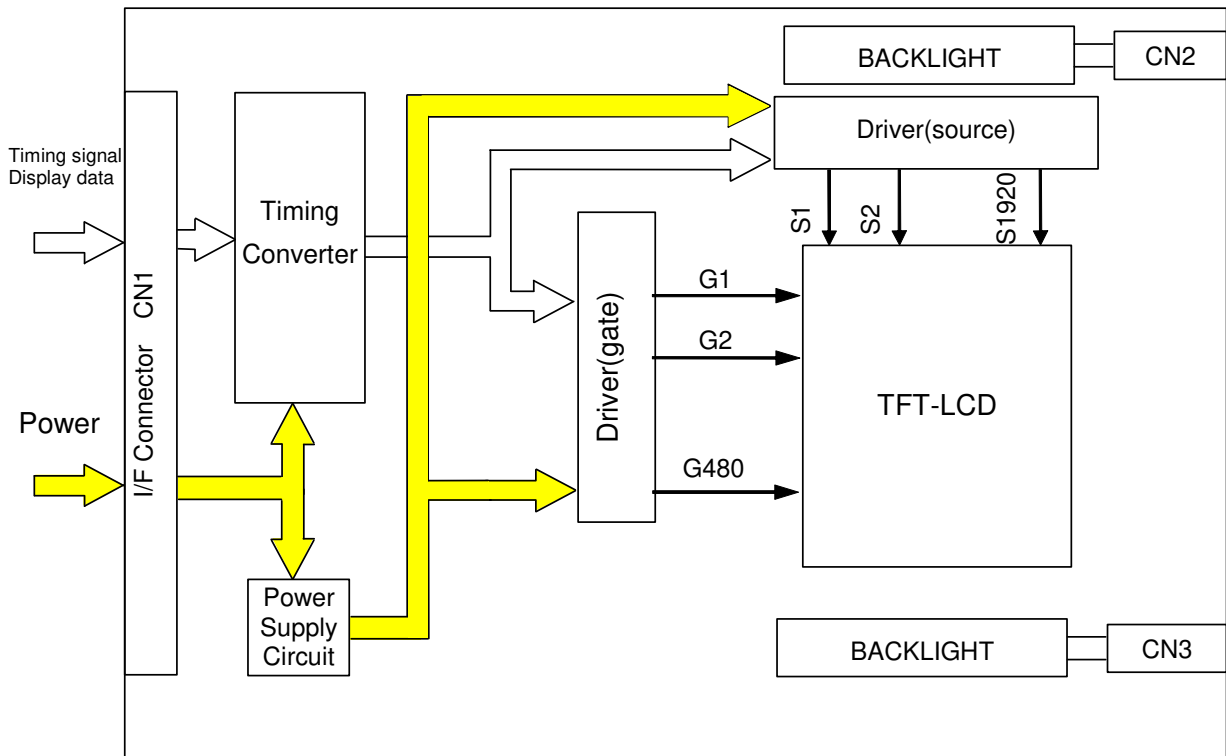

6. Pin assignment

CN 1 (INTERFACE SIGNAL)

Used connector: DF9B-31P-1V (Hirose)

Corresponding connector: DF9B-31S-1V (Hirose)

Pin No.	Symbol	Function
1	GND	
2	DCLK	Clock signal for sampling catch data signal
3	HD	Horizontal sync signal
4	VD	Vertical sync signal
5	GND	
6	R0	Red data signal(LSB)
7	R1	Red data signal
8	R2	Red data signal
9	R3	Red data signal
10	R4	Red data signal
11	R5	Red data signal(MSB)
12	GND	
13	G0	Green data signal(LSB)
14	G1	Green data signal
15	G2	Green data signal
16	G3	Green data signal
17	G4	Green data signal
18	G5	Green data signal(MSB)
19	GND	
20	B0	Blue data signal(LSB)
21	B1	Blue data signal
22	B2	Blue data signal
23	B3	Blue data signal
24	B4	Blue data signal
25	B5	Blue data signal(MSB)
26	GND	
27	DENA	Data enable signal(to settle the viewing area)
28	VCC	Power Supply (DC 3.3V or 5V)
29	VCC	Power Supply (DC 3.3V or 5V)
30	TEST	This pin should be open. Test signal output for only internal test use.
31	REV	Reverse scan control. L = Normal, H = Reverse

*) The shielding case is connected with GND

CN 2 Used connector: SHLP-06V-S-B(JST)

Corresponding connector: SM06-SHLS-TF(JST)

Pin No.	Symbol	Function
1	ANODE-1(RED)	LED Anode Terminal
2	ANODE-2(RED)	LED Anode Terminal
3	NC	Non-connection
4	NC	Non-connection
5	CATHODE-1(BLACK)	LED Cathode Terminal
6	CATHODE-2(BLACK)	LED Cathode Terminal

CN 3 Used connector: SHLP-06V-S-B(JST)

Corresponding connector: SM06-SHLS-TF(JST)

Pin No.	Symbol	Function
1	ANODE-3(RED)	LED Anode Terminal
2	ANODE-4(RED)	LED Anode Terminal
3	NC	Non-connection
4	NC	Non-connection
5	CATHODE-3(BLACK)	LED Cathode Terminal
6	CATHODE-4(BLACK)	LED Cathode Terminal

CN4 (Touch Panel)

Used FPC: P1.0mm, 4Pin, T=0.3mm

Corresponding connector: 6227 Series(ELCO)

No.	Symbol	Functional Description
1	XL	X left side
2	YD	Y 6o`clock side
3	XR	X right side
4	YU	Y 12o`clock side

7. Electrical Specifications

7.1. Absolute Maximum Ratings

Parameter	Symbol	Conditions	Min.	Max.	Unit
Supply Voltage for LCD	VCC	-	0	5.5	V
Logic Input Voltage	VI	-	-0.3	5.5	V

7.2. DC characteristics

(1) TFT-LCD

Ambient Temperature : Ta = 25°C

ITEM	SYMBOL	MIN.	TYP.	MAX.	UNIT	Remarks	
Power Supply Voltages for LCD Note A)	VCC	3.0	3.3	3.6	V	for 3.3V system	
		4.5	5.0	5.5	V	for 5V system	
Power Supply Currents for LCD Note B)	ICC	--	240	--	mA	for 3.3V system	
		--	180	--	mA	for 5V system	
Permissive input ripple Voltage	VRP	--	--	100	mVp-p	VCC=+3.3V	
		--	--	100	mVp-p	VCC=+5.0V	
Logic Input Voltage	High	VIH	2.4	--	5.5	V	VCC=MAX
	Low	VIL	--	--	0.8	V	VCC=MIN

[Note]

A) VCC-dip conditions:

- 1) When $2.4\text{ V} \leq VCC < 3.0\text{ V}$ or 4.5V , $t_d \leq 10\text{ ms}$
- 2) When $VCC < 2.4\text{ V}$

VCC-dip conditions should also follow the power and signals sequence.

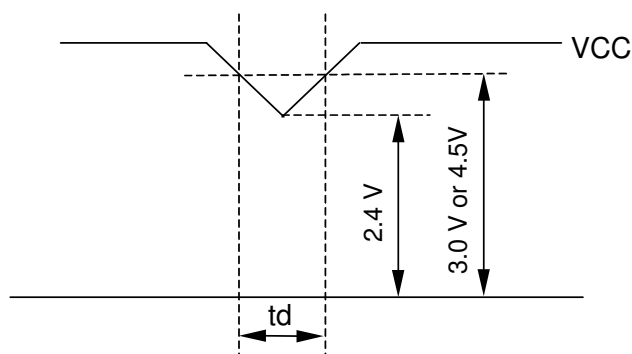

B) Typical current condition:

64- gray- bar-pattern

480 line mode

VCC = +3.3 V, $f_H=31.5\text{kHz}$, $f_V=60\text{Hz}$, $f_{CLK}= 25\text{MHz}$

VCC = +5.0 V, $f_H=31.5\text{kHz}$, $f_V=60\text{Hz}$, $f_{CLK}= 25\text{MHz}$

7.3.AC Characteristic

ITEM		SYMBOL	MIN.	TYP.	MAX.	UNIT
DCLK	Frequency	f_{CLK}	20	25	30	MHz
	Period	t_{CLK}	33.3	40	50	ns
	Low Width	t_{WCL}	10	--	--	ns
	High Width	t_{WCH}	10	--	--	ns
DATA (R,G,B,DENA, HD, VD)	Set up time	t_{DS}	5	--	--	ns
	Hold time	t_{DH}	5	--	--	ns
DENA	Horizontal Active Time	t_{HA}	640	640	640	t_{CLK}
	Horizontal Front Porch	t_{HFP}	0	--	--	t_{CLK}
	Horizontal Back Porch	t_{HBP}	7	--	--	t_{CLK}
	Vertical Active Time	t_{VA}	480	480	480	t_H
	Vertical Front Porch	t_{VFP}	1	20	--	t_H
	Vertical Back Porch	t_{VBP}	8	20	--	t_H
HD	Frequency	f_H	27	31.5	38	kHz
	Period	t_H	26.3	31.7	37.0	μs
	Low Width	t_{WHL}	5	--	--	t_{CLK}
VD	Frequency	f_V	55	60	70	Hz
	Period	t_V	14.3	16.7	18.2	ms
	Low Width	t_{WVL}	3	--	--	t_H

[Note]

- 1) DATA is latched at fall edge of DCLK in this timing specification.
- 2) Polarities of HD and VD are negative in this specification.
- 3) DENA (Data Enable) should always be positive polarity as shown in the timing specification.
- 4) DCLK should appear during all invalid period, and HD should appear during invalid period of frame cycle.
- 5) Accepted only 640 data and 480 lines.
- 6) REV should be stable during operation.

7) Please consider the influence of the filter circuit which is placed in the Signal Input, DCLK and Data Bus, when designing the circuit. AC Characteristic spec is based on ideal signal driving.

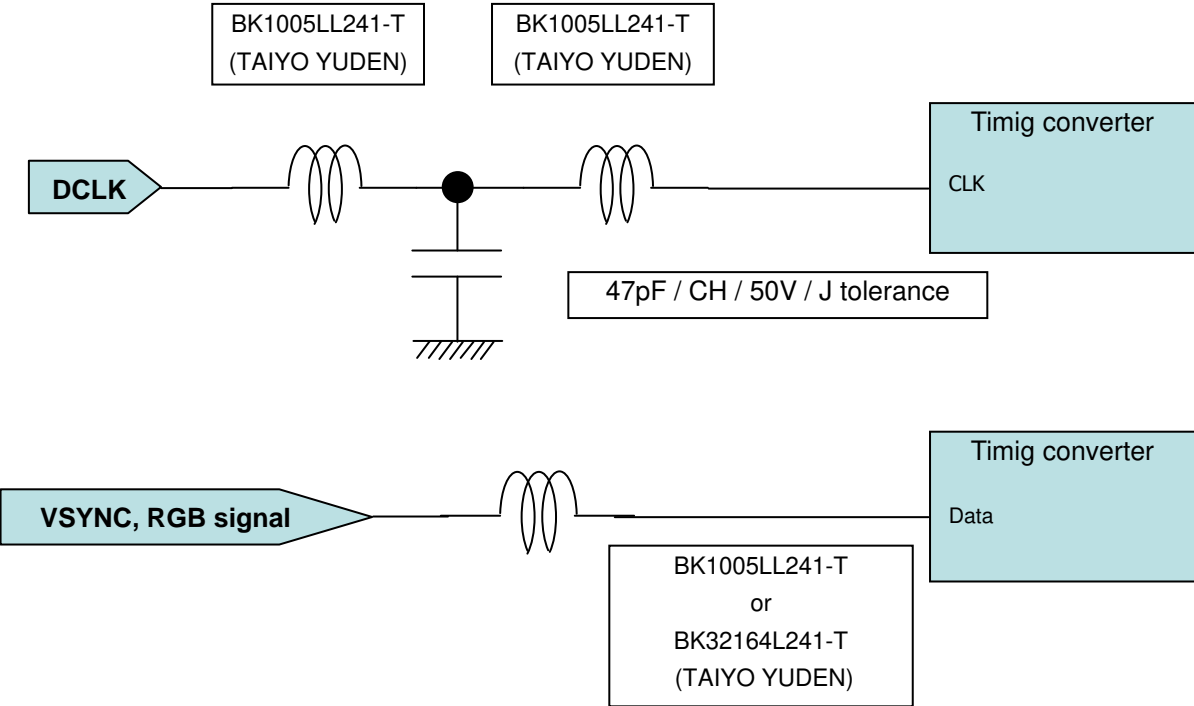

7.4. Timing Chart

a. Pixel Timing Chart

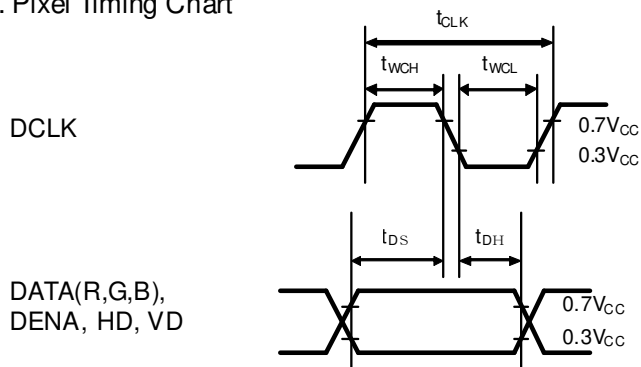

b. Horizontal Timing Chart

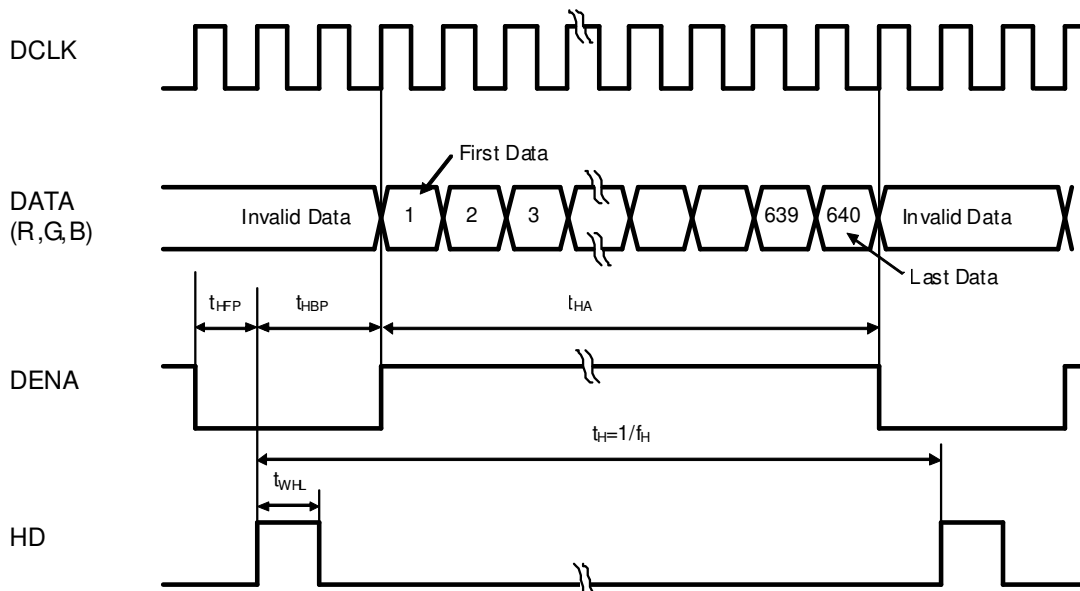

c. Vertical Timing Chart

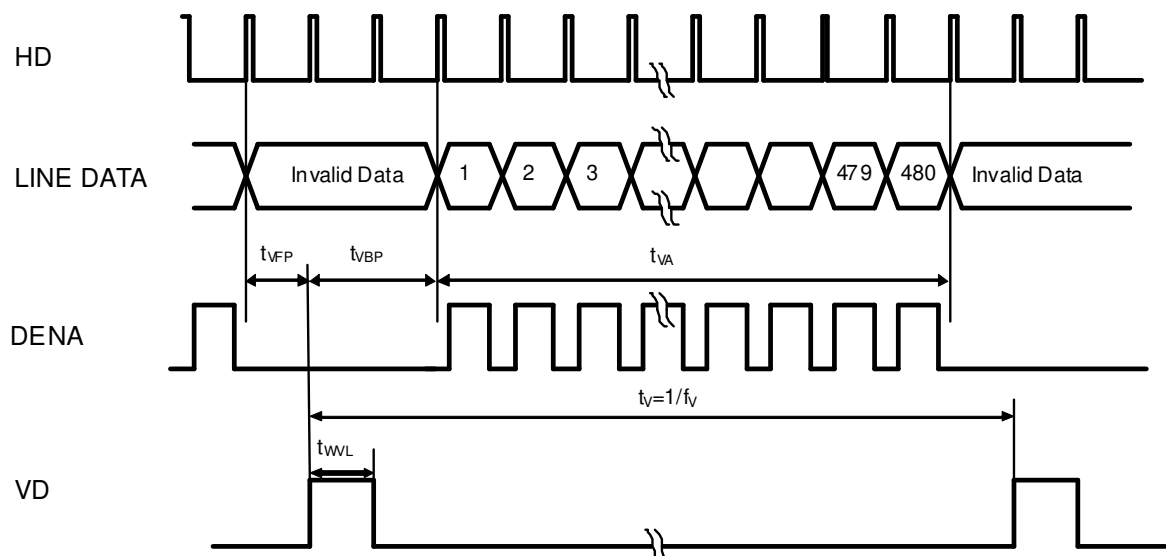

7.5. Power and signals sequence:

- $t1 \leq 10 \text{ ms}$
- $0 < t2 \leq 50 \text{ ms}$
- $0 < t3 \leq 50 \text{ ms}$
- $0 < t4 \leq 50 \text{ ms}$
- $500 \text{ ms} < t5$
- $200 \text{ ms} < t6$
- $0 \leq t7$

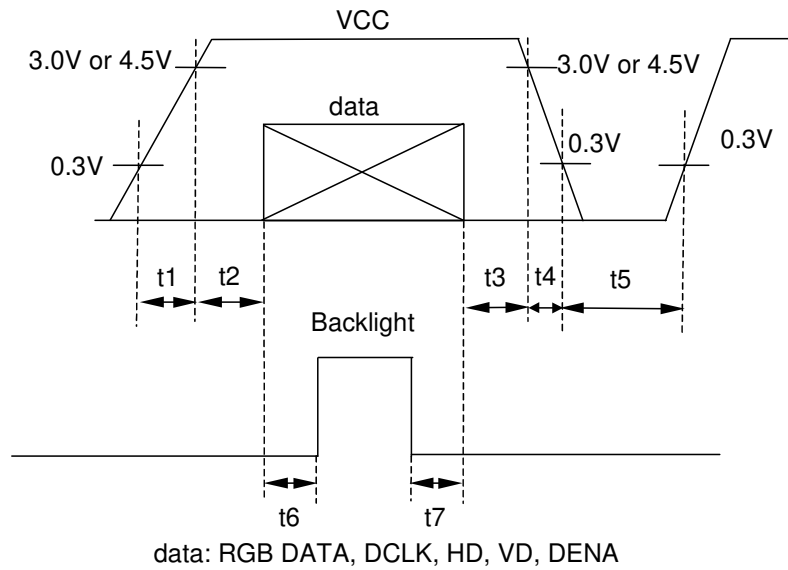

7.6. Pixel Alignment

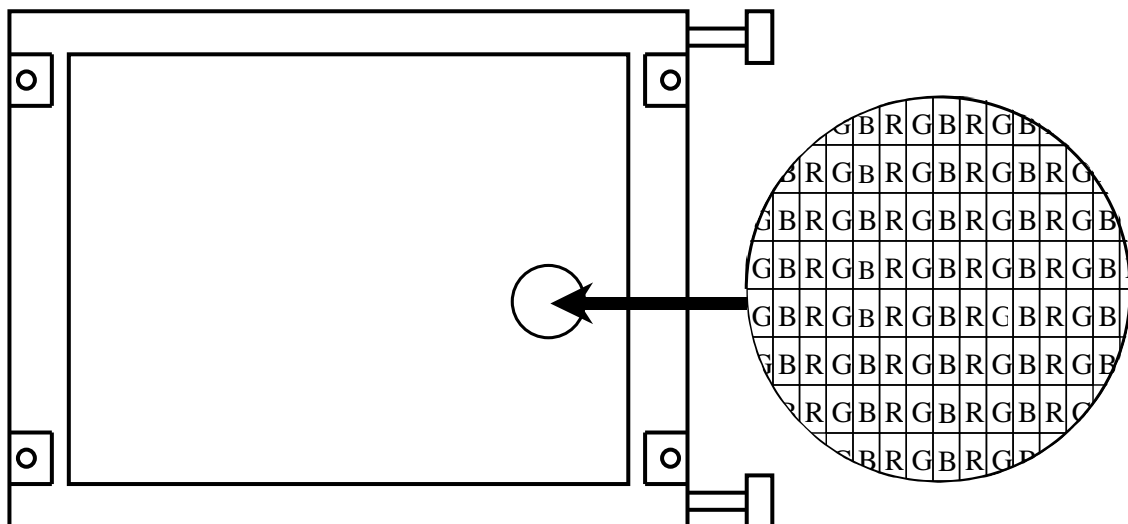

7.7.Color Data Assignment

COLOR	INPUT DATA	R DATA						G DATA						B DATA					
		MSB			LSB			MSB			LSB			MSB			LSB		
		R5	R4	R3	R2	R1	R0	G5	G4	G3	G2	G1	G0	B5	B4	B3	B2	B1	B0
BASIC COLOR	BLACK	0	0	0	0	0	0	0	0	0	0	0	0	0	0	0	0	0	0
	RED (63)	1	1	1	1	1	1	0	0	0	0	0	0	0	0	0	0	0	0
	GREEN (63)	0	0	0	0	0	0	1	1	1	1	1	1	0	0	0	0	0	0
	BLUE (63)	0	0	0	0	0	0	0	0	0	0	0	0	1	1	1	1	1	1
	CYAN	0	0	0	0	0	0	1	1	1	1	1	1	1	1	1	1	1	1
	MAGENTA	1	1	1	1	1	1	0	0	0	0	0	0	1	1	1	1	1	1
	YELLOW	1	1	1	1	1	1	1	1	1	1	1	1	0	0	0	0	0	0
	WHITE	1	1	1	1	1	1	1	1	1	1	1	1	1	1	1	1	1	1
RED	RED (0)	0	0	0	0	0	0	0	0	0	0	0	0	0	0	0	0	0	0
	RED (1)	0	0	0	0	0	1	0	0	0	0	0	0	0	0	0	0	0	0
	RED (2)	0	0	0	0	1	0	0	0	0	0	0	0	0	0	0	0	0	0
	RED (62)	1	1	1	1	1	0	0	0	0	0	0	0	0	0	0	0	0	0
	RED (63)	1	1	1	1	1	1	0	0	0	0	0	0	0	0	0	0	0	0
GREEN	GREEN (0)	0	0	0	0	0	0	0	0	0	0	0	0	0	0	0	0	0	0
	GREEN (1)	0	0	0	0	0	0	0	0	0	0	0	1	0	0	0	0	0	0
	GREEN (2)	0	0	0	0	0	0	0	0	0	0	1	0	0	0	0	0	0	0
	GREEN (62)	0	0	0	0	0	0	1	1	1	1	1	0	0	0	0	0	0	0
	GREEN (63)	0	0	0	0	0	0	1	1	1	1	1	1	0	0	0	0	0	0
BLUE	BLUE (0)	0	0	0	0	0	0	0	0	0	0	0	0	0	0	0	0	0	0
	BLUE (1)	0	0	0	0	0	0	0	0	0	0	0	0	0	0	0	0	0	1
	BLUE (2)	0	0	0	0	0	0	0	0	0	0	0	0	0	0	0	0	1	0
	BLUE (62)	0	0	0	0	0	0	0	0	0	0	0	0	1	1	1	1	1	0
	BLUE (63)	0	0	0	0	0	0	0	0	0	0	0	0	1	1	1	1	1	1

[Note]

- 1) Definition of gray scale
Color (n) --- n indicates gray scale level.
Higher n means brighter level.
- 2) Data 1:High, 0: Low

7.8. Inverted Scan Capability

This module has the capability of inverting scan direction by signaling from controller.

Note that scan direction cannot be changed during operation.

The following figure shows the relation between the display position and the scan direction.

DISPLAY POSITION

Normal scan: REV = "L"

D(1, 1)	D(2, 1)	---	D(X, 1)	---	D(639, 1)	D(640, 1)
D(1, 2)	D(2, 2)	---	D(X, 2)	---	D(639, 2)	D(640, 2)
↓	↓	+	+	+	↓	↓
D(1, Y)	D(2, Y)	---	D(X, Y)	---	D(639, Y)	D(640, Y)
↓	↓	+	+	+	↓	↓
D(1,479)	D(2,479)	---	D(X,479)	---	D(639,479)	D(640,479)
D(1,480)	D(2,480)	---	D(X,480)	---	D(639,480)	D(640,480)

Reverse scan: REV = "H"

D(640,480)	D(639,480)	---	D(X,480)	---	D(2,480)	D(1,480)
D(640,479)	D(639,479)	---	D(X,479)	---	D(2,479)	D(1,479)
↓	↓	+	+	+	↓	↓
D(640, Y)	D(639, Y)	---	D(X, Y)	---	D(2, Y)	D(1, Y)
↓	↓	+	+	+	↓	↓
D(640, 2)	D(639, 2)	---	D(X, 2)	---	D(2, 2)	D(1, 2)
D(640, 1)	D(639, 1)	---	D(X, 1)	---	D(2, 1)	D(1, 1)

The following drawing shows the relationship between the viewing direction and the scan direction.

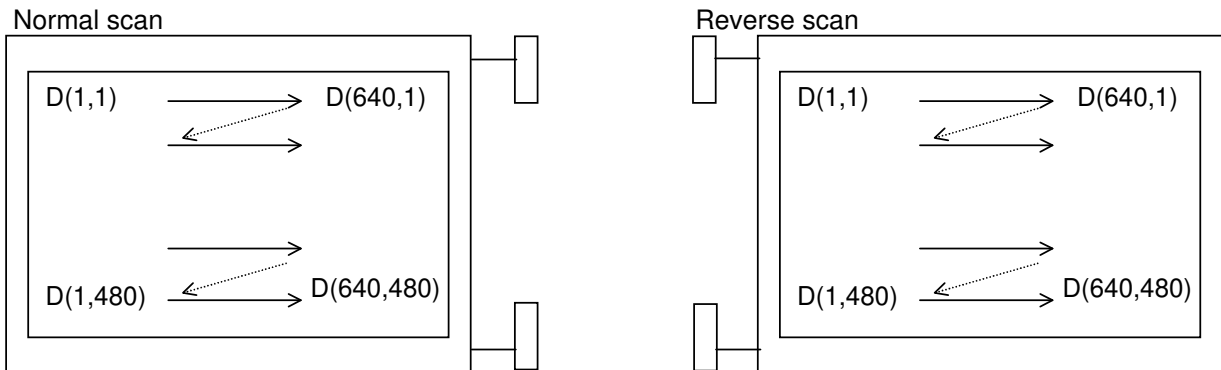

7.9. Lighting Specifications

7.9.1. Absolute Maximum Ratings

Ta=25°C

Parameter	Symbol	Conditions	Min.	Typ.	Max.	Units
Foward Current	I _F	Note 2	-	-	40	mA
Allowable Reverse Current	I _R	-	-	-	85	mA
LED Power Dissipation	P _D	-	-	-	1.28	W

Note 1 : Tiis value is for each 1 line.

Note 2 : Refer to the foward current derating curve.

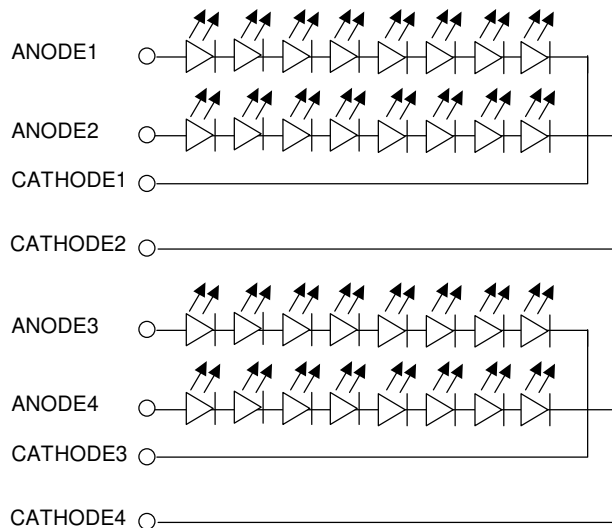
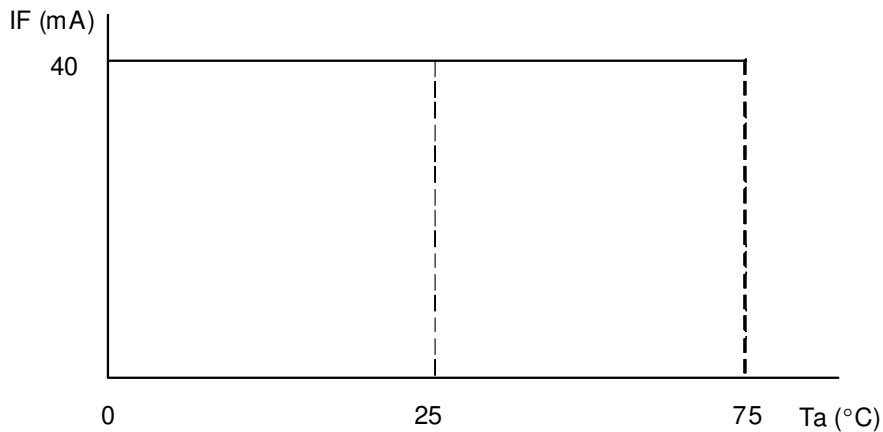

7.9.2. Operating Characteristics

Ta=25°C

Parameter	Symbol	Conditions	Min.	Typ.	Max.	Units
Foward Voltage	V _F	I _F =35mA / 1 line	-	26.4	31.2	V

7.10. Touch Panel Specifications

7.10.1. Touch Panel Characteristics

Ta=-10~60°C

Parameter		Min.	Typ.	Max.	Units	Conditions
Max Voltage		-	-	5.5	V	
Resistor between Terminals	XL-LR	300	-	1000	Ω	
	YU-UD	100		500	Ω	
Line Linearity		-	-	±1.5	%	Initial Value
Insulation Resistance		10	-	-	MΩ	At DC25V
Operation Force		10	-	100	g	Initial Value

8. Optical Specifications

Item	Symbol	Conditions			Standard Value			Unit	Method of Measure	Remark	
		θ	ϕ	C	Min.	Typ.	Max.				
Brightness	B	0°	0°	/	-	800	-	cd/m ²	(Fig.3-1)	Note3-1	
Contrast	CR	Best Viewing			400	800	-	-			
Color Coordinates	Red	Rx	0°	0°	/	-	0.60	-		-	
		Ry	0°	0°	/	-	0.35	-		-	
	Green	Gx	0°	0°	/	-	0.33	-		-	
		Gy	0°	0°	/	-	0.59	-		-	
	Blue	Bx	0°	0°	/	-	0.16	-		-	
		By	0°	0°	/	-	0.13	-		-	
	White	Wx	0°	0°	/	-	0.32	-		-	
Wy		0°	0°	/	-	0.35	-	-			
Brightness Uniformity	-	0°	0°	/	0.7	-	-	-	(Fig.3-2)		
Vertical Viewing Angle	Up	θ_U	-	0°	≥ 10	-	50	-	Degree	(Fig.3-3)	
	Down	θ_D	-	0°	≥ 10	-	70	-	Degree		
Horizontal Viewing Angle	Left	ϕ_L	0°	-	≥ 10	-	80	-	Degree		
	Right	ϕ_R	0°	-	≥ 10	-	80	-	Degree		
Response Time	Rise	τ_r	0°	0°	/	-	15	-	ms	(Fig.3-4)	
	Decay	τ_d	0°	0°	/	-	16	-	ms		
Haze	H	/			-	9	-	%			

Note3-1: Under the condition of maximum brightness.

- ◆ Conditions for Measuring
 - ◇ Environment: Dark room with no light or close to no light.
 - ◇ Temperature: 25±5°C
 - ◇ Humidity: 40~70%RH
- ◆ Optimal viewing angle (The angle with best contrast)

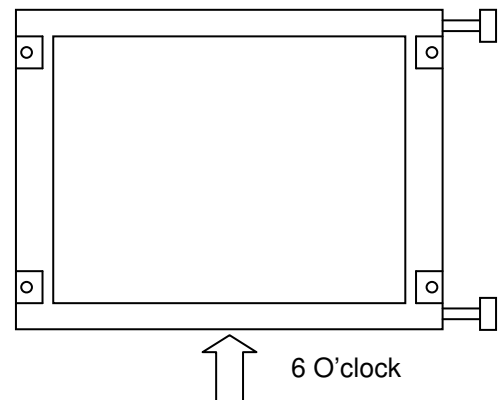

(Fig.3-1)

◆ Method of Brightness Measurement

(1) Measuring Device

TOPCON BM-5, Measuring Field: 1°

(2) Measuring Point

Center of Display $\theta=0^\circ, \phi=0^\circ$

On condition θ : A vertical angle from measuring direction to perpendicular.

ϕ : A horizontal angle from measuring direction to perpendicular.

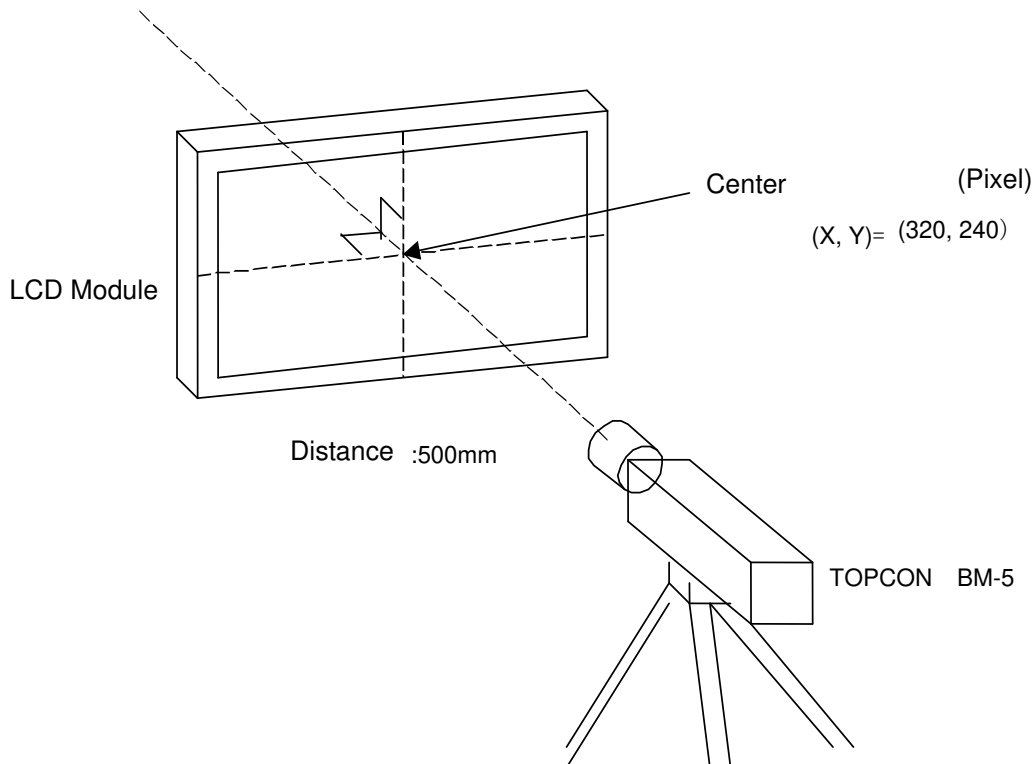

(3) Method of Measuring

Apply signal voltage (displayed in white) to maximize brightness and measure brightness B (cd/m^2).

The distance between BM-5's front lens to surface panel is 500mm.

Measured after backlight has been lit for more than 30 minutes.

◆ Method of Contrast Measurement

(1) Measuring Device

TOPCON BM-5, Measuring Field: 1°

(2) Measuring Point

Center of display: same as Method of Brightness Measurement

(3) Method of Measuring

- Set LCD module to $\theta=0^\circ, \phi=0^\circ$.
- Change signal voltage to measure maximum brightness $Y1$ and minimum brightness $Y2$.
- Contrast is derived from $CR=Y1/Y2$.

(Fig.3-2)

◆ Definition of Brightness Uniformity

Definition is calculated from the 5 points (S0-S4) on the diagram below.

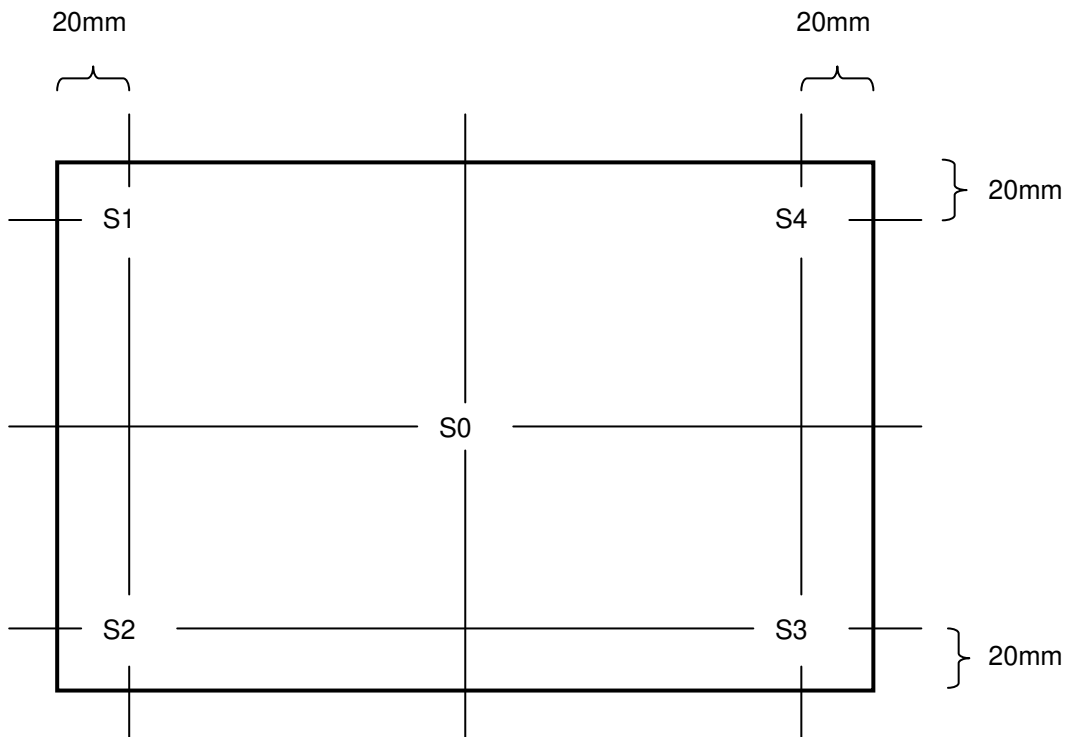

$$\text{Standard Value of Brightness Uniformity} = \frac{\text{Minimum Value of S1-S4}}{S0}$$

(Fig.3-3)

◆ Method of Viewing Angle Measurement

(1) Measuring Device

ELDIM: EZ CONTRAST, Measuring Field: 1°

(2) Measuring Point

Center of display : Same as Method of Brightness Measurement

(3) Angle of Measuring

θ : An angle vertical to perpendicular line from the viewing direction.

ϕ : An angle horizontal to perpendicular from the viewing direction.

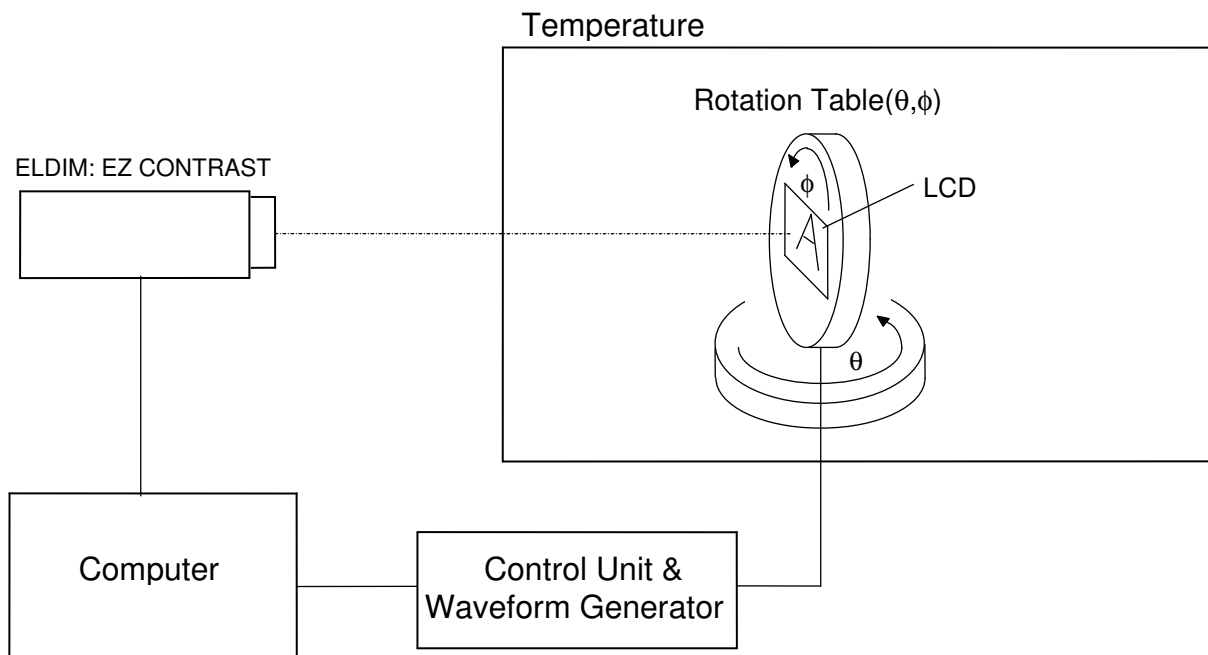

(4) Method of Measuring

Set the module on the rotation table and measure a vertical axis direction in the state that fixed $\phi = 0$ degrees horizontal axis direction to $\theta = 90$ degrees.

(Viewing angle is measured automatically by EZ CONTRAST)

(Fig.3-4)

◆ Measuring Response Time

- (1) Measuring Device
TOPCON BM-5, Measuring Field: 1°
Tektronix Digital Oscilloscope
- (2) Measuring Point
Center of display, same as Method of Brightness Measurement
- (3) Method of Measuring
 - Set LCD panel to $\theta=0^\circ$, and $\phi=0^\circ$.
 - Input white \rightarrow black \rightarrow white to display by switching signal voltage.
 - If the luminance is 0% and 100% immediately before the change of signal voltage, then τ_r is optical response time during the change from 90% to 10% immediately after rise of signal voltage, and τ_d is optical response time during the change from 10% to 90% immediately after decay of signal voltage.

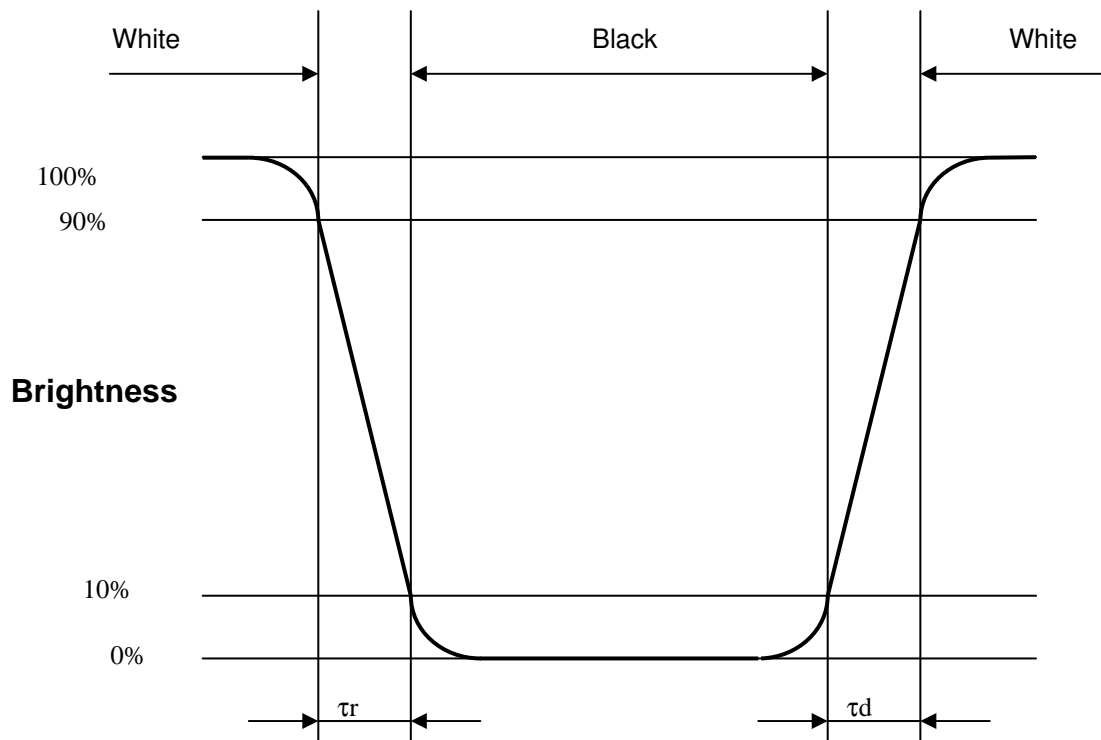

9. Test

No abnormal function and appearance are found after the following tests.

Conditions: Unless otherwise specified, tests will be conducted under the following condition.

Temperature: $20 \pm 5^\circ\text{C}$

Humidity : $65 \pm 5\% \text{RH}$

tests will be not conducted under functioning state.

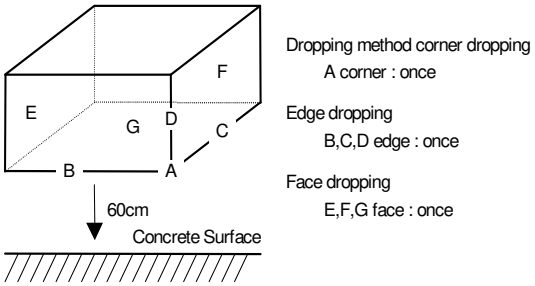
No.	Parameter	Conditions	Notes
1	High Temperature Operating	70°C , 96hrs (operation state)	
2	High Temperature Storage	70°C , 96hrs	2
3	Low Temperature Storage	-20°C , 96hrs	1,2
4	Damp Proof Test	40°C , $90 \sim 95\% \text{RH}$, 96hrs	1,2
5	Vibration Test	Frequency: $10 \sim 57 \text{Hz}$ / Vibration width (one side): 0.75mm : $58 \sim 500 \text{Hz}$ / Gravity: 9.8m/s^2 Sweep time: 11 minutes Test period: 3hrs for each direction of X, Y, Z	3
6	Shock	Shock level: 490m/s^2 Waveform: half sinusoidal wave, 11ms Number of shocks : One shock input in each direction of three mutually perpendicular axis for a total of six shock inputs	
7	Shock Test	To be measured after dropping from 60cm high on the concrete surface in packing state. 	

Note 1: No dew condensation to be observed.

Note 2: The function test shall be conducted after 4 hours storage at the normal Temperature and humidity after removed from the test chamber.

Note 3: Vibration test will be conducted to the product itself without putting it in a container.

10. Appearance Standards

10.1. Inspection conditions

The LCD shall be inspected under 40W white fluorescent light.

The distance between the eyes and the sample shall be more than 30cm.

All directions for inspecting the sample should be within 45° against perpendicular line.

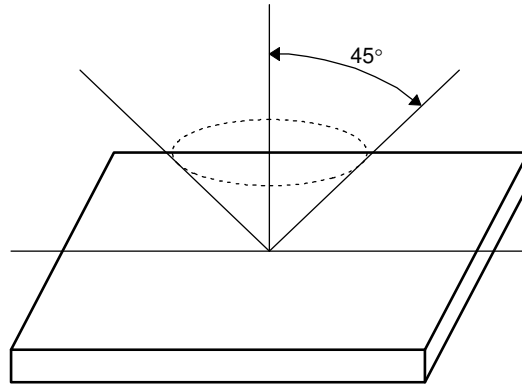

10.2. Definition of applicable Zones

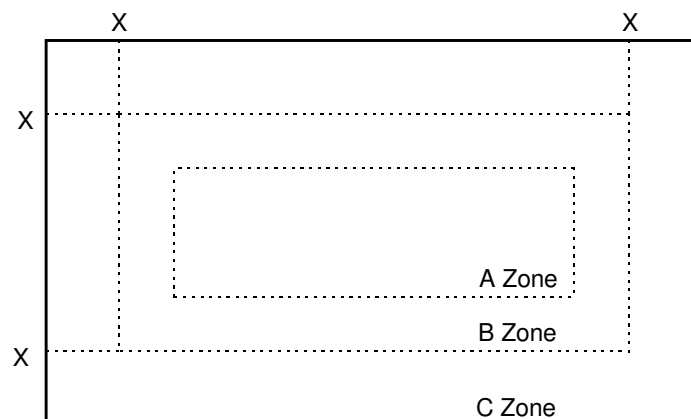

X : Maximum Seal Line

A Zone : Active display area

B Zone : Out of active display area up to viewing area

C Zone : Rest parts

A Zone + B Zone = Viewing area

10.3.Standards

No.	Parameter	Criteria																												
1	Polarizer Scratches	<table border="1"> <thead> <tr> <th colspan="2" rowspan="2">Zone</th> <th colspan="3">Acceptable Number</th> </tr> <tr> <th>A</th> <th>B</th> <th>C</th> </tr> </thead> <tbody> <tr> <td>X(mm) \ Y(mm)</td> <td></td> <td></td> <td></td> <td></td> </tr> <tr> <td>L ≤ 15</td> <td>0.01 < W ≤ 0.05</td> <td>4</td> <td></td> <td>*</td> </tr> <tr> <td>L > 15</td> <td>W > 0.01</td> <td>0</td> <td></td> <td>*</td> </tr> <tr> <td>-</td> <td>W > 0.05</td> <td>0</td> <td></td> <td>*</td> </tr> </tbody> </table> <p>X : Length, Y : Width * : Disregard</p>	Zone		Acceptable Number			A	B	C	X(mm) \ Y(mm)					L ≤ 15	0.01 < W ≤ 0.05	4		*	L > 15	W > 0.01	0		*	-	W > 0.05	0		*
Zone		Acceptable Number																												
		A	B	C																										
X(mm) \ Y(mm)																														
L ≤ 15	0.01 < W ≤ 0.05	4		*																										
L > 15	W > 0.01	0		*																										
-	W > 0.05	0		*																										
2	DENT	<table border="1"> <thead> <tr> <th colspan="2" rowspan="2">Zone</th> <th colspan="3">Acceptable Number</th> </tr> <tr> <th>A</th> <th>B</th> <th>C</th> </tr> </thead> <tbody> <tr> <td colspan="2">Dimension (mm)</td> <td></td> <td></td> <td></td> </tr> <tr> <td colspan="2">0.30 < D ≤ 0.50</td> <td>4</td> <td></td> <td>*</td> </tr> <tr> <td colspan="2">0.50 < D</td> <td>0</td> <td></td> <td>*</td> </tr> </tbody> </table> <p>D : Average Diameter = (long+short)/2 * : Disregard</p>	Zone		Acceptable Number			A	B	C	Dimension (mm)					0.30 < D ≤ 0.50		4		*	0.50 < D		0		*					
Zone		Acceptable Number																												
		A	B	C																										
Dimension (mm)																														
0.30 < D ≤ 0.50		4		*																										
0.50 < D		0		*																										
3	BLACK and WHITE SPOT BUBBLE	<table border="1"> <thead> <tr> <th colspan="2" rowspan="2">Zone</th> <th colspan="3">Acceptable Number</th> </tr> <tr> <th>A</th> <th>B</th> <th>C</th> </tr> </thead> <tbody> <tr> <td colspan="2">Dimension (mm)</td> <td></td> <td></td> <td></td> </tr> <tr> <td colspan="2">0.30 < D ≤ 0.50</td> <td>5</td> <td></td> <td>*</td> </tr> <tr> <td colspan="2">0.50 < D</td> <td>0</td> <td></td> <td>*</td> </tr> </tbody> </table>	Zone		Acceptable Number			A	B	C	Dimension (mm)					0.30 < D ≤ 0.50		5		*	0.50 < D		0		*					
Zone		Acceptable Number																												
		A	B	C																										
Dimension (mm)																														
0.30 < D ≤ 0.50		5		*																										
0.50 < D		0		*																										
4	LINT	<table border="1"> <thead> <tr> <th colspan="2" rowspan="2">Zone</th> <th colspan="3">Acceptable Number</th> </tr> <tr> <th>A</th> <th>B</th> <th>C</th> </tr> </thead> <tbody> <tr> <td>X(mm) \ Y(mm)</td> <td></td> <td></td> <td></td> <td></td> </tr> <tr> <td>L ≤ 3.0</td> <td>W ≤ 0.15</td> <td>4</td> <td></td> <td>*</td> </tr> <tr> <td>L > 3.0</td> <td>W ≤ 0.15</td> <td>0</td> <td></td> <td>*</td> </tr> <tr> <td>-</td> <td>W > 0.15</td> <td colspan="2">According to BLACK SPOT</td> <td>*</td> </tr> </tbody> </table> <p>X : Length, Y : Width * : Disregard</p>	Zone		Acceptable Number			A	B	C	X(mm) \ Y(mm)					L ≤ 3.0	W ≤ 0.15	4		*	L > 3.0	W ≤ 0.15	0		*	-	W > 0.15	According to BLACK SPOT		*
Zone		Acceptable Number																												
		A	B	C																										
X(mm) \ Y(mm)																														
L ≤ 3.0	W ≤ 0.15	4		*																										
L > 3.0	W ≤ 0.15	0		*																										
-	W > 0.15	According to BLACK SPOT		*																										

No.	Parameter	Criteria																			
5	(a) Bright Dot (b) Dark Dot	<table border="1"> <thead> <tr> <th rowspan="2">Zone Dimension (mm)</th> <th colspan="3">Acceptable Number</th> </tr> <tr> <th>A</th> <th>B</th> <th>C</th> </tr> </thead> <tbody> <tr> <td>Bright Dot</td> <td colspan="2">7 ($G \leq 3$)</td> <td>*</td> </tr> <tr> <td>Dark Dot</td> <td colspan="2">7</td> <td>*</td> </tr> <tr> <td>TOTAL</td> <td colspan="3">10</td> </tr> </tbody> </table>	Zone Dimension (mm)	Acceptable Number			A	B	C	Bright Dot	7 ($G \leq 3$)		*	Dark Dot	7		*	TOTAL	10		
		Zone Dimension (mm)		Acceptable Number																	
			A	B	C																
		Bright Dot	7 ($G \leq 3$)		*																
Dark Dot	7		*																		
TOTAL	10																				
6	TWO Adjacent Dot	<table border="1"> <thead> <tr> <th rowspan="2">Zone Dimension (mm)</th> <th colspan="3">Acceptable Number</th> </tr> <tr> <th>A</th> <th>B</th> <th>C</th> </tr> </thead> <tbody> <tr> <td>Bright Dot</td> <td colspan="2">3 PAIRS</td> <td>*</td> </tr> <tr> <td>Dark Dot</td> <td colspan="2">3 PAIRS</td> <td>*</td> </tr> </tbody> </table>	Zone Dimension (mm)	Acceptable Number			A	B	C	Bright Dot	3 PAIRS		*	Dark Dot	3 PAIRS		*				
		Zone Dimension (mm)		Acceptable Number																	
			A	B	C																
Bright Dot	3 PAIRS		*																		
Dark Dot	3 PAIRS		*																		
7	Three or More Adjacent Dot	NOT ALLOWED																			
8		<table border="1"> <thead> <tr> <th rowspan="2">Zone Dimension (mm)</th> <th colspan="3">Acceptable Number</th> </tr> <tr> <th>A</th> <th>B</th> <th>C</th> </tr> </thead> <tbody> <tr> <td>Bright Dot</td> <td colspan="2">5 mm</td> <td>*</td> </tr> <tr> <td>Dark Dot</td> <td colspan="2">5 mm</td> <td>*</td> </tr> </tbody> </table>	Zone Dimension (mm)	Acceptable Number			A	B	C	Bright Dot	5 mm		*	Dark Dot	5 mm		*				
		Zone Dimension (mm)		Acceptable Number																	
			A	B	C																
Bright Dot	5 mm		*																		
Dark Dot	5 mm		*																		
9	Line Defect	NOT ALLOWED																			

Note 1: Bright Dot is defined as follows:

Visible through 5% transmission ND filter under the condition that black image (color 0) is on the display.

Note 2: Dark Dot is defined as follows:

Recognizable darker than around under the condition that each R(63), G(63), B(63) image is on the display.

Note 3: Definition of adjacent

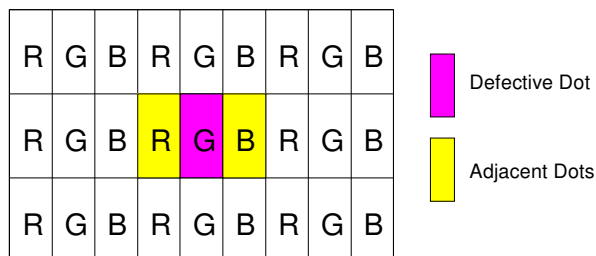

The defects that are not defined above and considered to be problem shall be reviewed and discussed by both parties.