



Chipsmall Limited consists of a professional team with an average of over 10 year of expertise in the distribution of electronic components. Based in Hongkong, we have already established firm and mutual-benefit business relationships with customers from,Europe,America and south Asia,supplying obsolete and hard-to-find components to meet their specific needs.

With the principle of “Quality Parts,Customers Priority,Honest Operation,and Considerate Service”,our business mainly focus on the distribution of electronic components. Line cards we deal with include Microchip,ALPS,ROHM,Xilinx,Pulse,ON,Everlight and Freescale. Main products comprise IC,Modules,Potentiometer,IC Socket,Relay,Connector.Our parts cover such applications as commercial,industrial, and automotives areas.

We are looking forward to setting up business relationship with you and hope to provide you with the best service and solution. Let us make a better world for our industry!



Contact us

Tel: +86-755-8981 8866 Fax: +86-755-8427 6832

Email & Skype: info@chipsmall.com Web: www.chipsmall.com

Address: A1208, Overseas Decoration Building, #122 Zhenhua RD., Futian, Shenzhen, China



LCD Module Technical Specification

First Edition
Mar. 14, 2008

Final Revision
Apr. 15, 2008

Type No. **T-55265GD057J-LW-ABN**

Customer : **OPTREX STANDARD**

Customer's Product No : -----

OPTREX CORPORATION

Approved: Minoru Akatsuka
QUALITY ASSURANCE DIVISION

Checked: Toshiyuki Okamoto
DESIGN 2T

Prepared: Takashi Yuchi
DESIGN 2T

APPROVED

By

Signature :

Date :

Please return this specification within two month with your signature.
If not returned within two month, specification will be considered
as having been accepted.

Table of Contents

- 1. Application..... 3
- 2. General Specifications..... 3
- 3. Operating Conditions..... 3
- 4. Dimensinal Outline 4
- 5. Block Diagram..... 5
- 6. I/O Terminal..... 6
- 7. Electrical Specifications..... 8
- 8. Optical Specifications 15
- 9. Test 21
- 10. Appearance Standards..... 22
- 11. Code System of Production Lot 25
- 12. Type Number..... 25
- 13. Applying Precautions..... 25
- 14. Precautions Relating Product Handling..... 26
- 15. Warranty..... 27

Revision History

Rev.	Date	Page	Comment
1	Apr.15 2008	4	4. Dimensinal Outline
			Revise of Dimensinal Outline Rev.A →Rev.B
		10	7.3.2.Input Signal Timing
			Correction of CK Signal Timing

1.Application

This specification applies to 5.7"color TFT-LCD module (T-55265GD057J-LW-ABN).

2.General Specifications

Dot Pixels	:	320×3 [R.G.B] (W) × 240 (H) dots
Dot Size	:	0.12×3 [R.G.B] (W) × 0.36 (H) mm
Pixel Arrangement	:	RGB-Stripe
Color Depth	:	262,144 colors
Viewing Area	:	117.88 (W) × 88.24 (H) mm
Outline Dimensions	:	144.0 (W) × 104.6* (H) × 13.5max. (D) mm * Without LED Cable
Weight	:	255.0g max.
LCD Type	:	ATS-25837 (TFT / Normally white-mode / Transmissive)
Viewing Angle	:	6:00 (Angle of Least Color Inversion)
Interface	:	18-bit RGB interface(6-bit / color)
Backlight	:	LED Backlight / White
RoHS regulation	:	To our best knowledge, this product satisfies material requirement of RoHS regulation. Our company is doing the best efforts to obtain the equivalent certificate from our suppliers.

3.Operating Conditions

Item	Conditions	Temperature Range	Remark
Operating Temperature Range	PNL Surface	-20~70°C	Note1
Storage Temperature Range	PNL Surface	-30~80°C	

Note1: Operating temperature range defines the operation only and the contrast, response time and other display optical characteristics are set at Ta=+25°C.

4. Dimensional Outline

ISSUE	REVISIONS	DRAWN	DATE
▲	Collection	S. SANDO	MAR. 10 '08
▲	ADDED THE DIMENSION	S. SANDO	APR. 10 '08

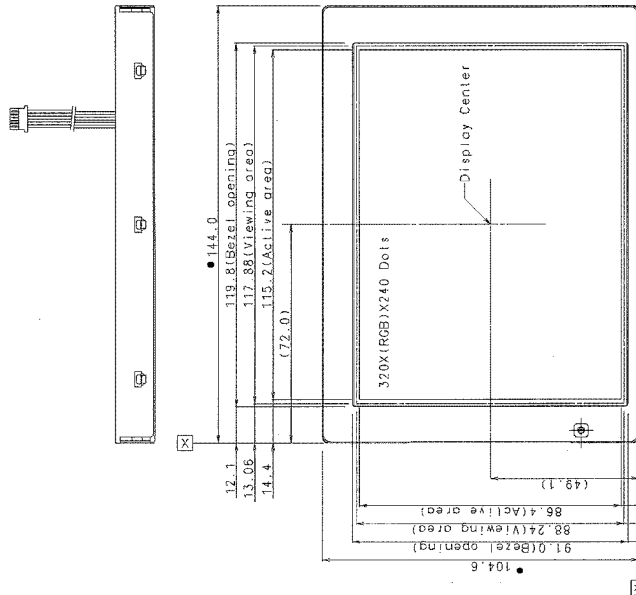
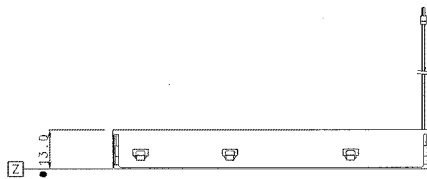
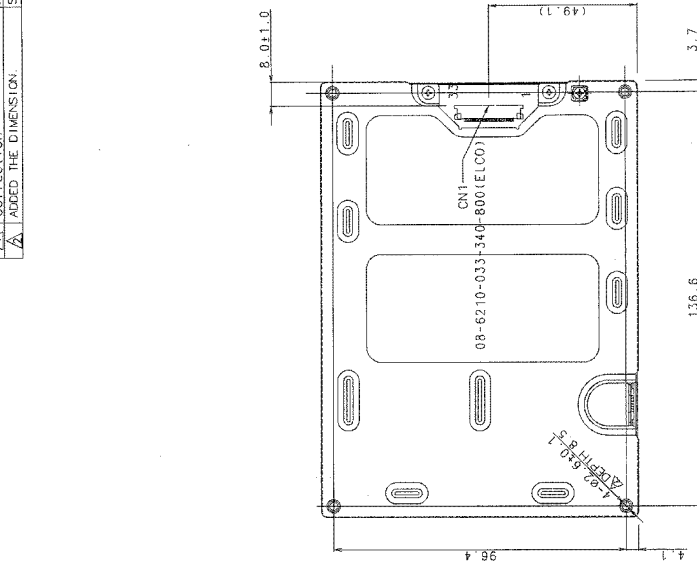

VIEWING DIRECTION :
DIRECTION THAT YOU CAN SEE THE DISPLAY MOST CLEAR.

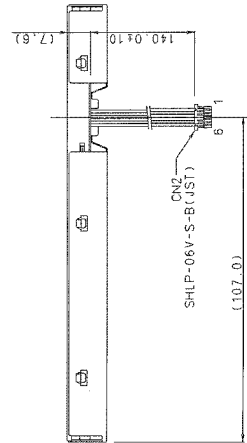
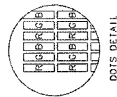

CN2

No.	SYMBOL	CABLE COLOR
1	Anode1	Black
2	Anode2	Red
3	Anode3	White
4	Cathode1	Black
5	Cathode2	Red
6	Cathode3	White

P.I.N. ASSIGNMENT

CN1			CN2		
No.	SYMBOL	No.	SYMBOL	No.	SYMBOL
1	GND	17	G4	1	Anode1
2	OK	18	G5	2	Anode2
3	HSYC	19	GND	3	Anode3
4	VSYNC	20	B0	4	Cathode1
5	GND	21	B1	5	Cathode2
6	R0	22	B2	6	Cathode3
7	R1	23	B3		
8	R2	24	B4		
9	R3	25	B5		
10	R4	26	GND		
11	R5	27	ENAB		
12	GND	28	VCC(0.3V)		
13	G0	29	VCC(0.3V)		
14	G1	30	R/L		
15	G2	31	U/D		
16	G3	32	NC		
		33	GND		

NOTE
1. The dimensions with the mark (●) are controlled as a particular characteristic.
2. Tolerance without indication: ±0.5

DATE	2008/04/11	SCALE	1:1
PROJ. NO.	08-6210-0333-340-8000	SCALE UNIT	mm
DESIGNER	S. SANDO	SCALE	1:1
CHECKER	S. SANDO	SCALE	1:1
DATE	2008/04/11	SCALE	1:1
PROJ. NO.	08-6210-0333-340-8000	SCALE	1:1
DESIGNER	S. SANDO	SCALE	1:1
CHECKER	S. SANDO	SCALE	1:1

MEASURE	TOLERANCE		
	A	B	C
0.0	±0.1	±0.1	±0.1
0.1	±0.1	±0.1	±0.1
0.2	±0.1	±0.1	±0.1
0.3	±0.1	±0.1	±0.1
0.4	±0.1	±0.1	±0.1
0.5	±0.1	±0.1	±0.1
0.6	±0.1	±0.1	±0.1
0.7	±0.1	±0.1	±0.1
0.8	±0.1	±0.1	±0.1
0.9	±0.1	±0.1	±0.1
1.0	±0.1	±0.1	±0.1
1.1	±0.1	±0.1	±0.1
1.2	±0.1	±0.1	±0.1
1.3	±0.1	±0.1	±0.1
1.4	±0.1	±0.1	±0.1
1.5	±0.1	±0.1	±0.1
1.6	±0.1	±0.1	±0.1
1.7	±0.1	±0.1	±0.1
1.8	±0.1	±0.1	±0.1
1.9	±0.1	±0.1	±0.1
2.0	±0.1	±0.1	±0.1
2.1	±0.1	±0.1	±0.1
2.2	±0.1	±0.1	±0.1
2.3	±0.1	±0.1	±0.1
2.4	±0.1	±0.1	±0.1
2.5	±0.1	±0.1	±0.1
2.6	±0.1	±0.1	±0.1
2.7	±0.1	±0.1	±0.1
2.8	±0.1	±0.1	±0.1
2.9	±0.1	±0.1	±0.1
3.0	±0.1	±0.1	±0.1
3.1	±0.1	±0.1	±0.1
3.2	±0.1	±0.1	±0.1
3.3	±0.1	±0.1	±0.1
3.4	±0.1	±0.1	±0.1
3.5	±0.1	±0.1	±0.1
3.6	±0.1	±0.1	±0.1
3.7	±0.1	±0.1	±0.1
3.8	±0.1	±0.1	±0.1
3.9	±0.1	±0.1	±0.1
4.0	±0.1	±0.1	±0.1
4.1	±0.1	±0.1	±0.1
4.2	±0.1	±0.1	±0.1
4.3	±0.1	±0.1	±0.1
4.4	±0.1	±0.1	±0.1
4.5	±0.1	±0.1	±0.1
4.6	±0.1	±0.1	±0.1
4.7	±0.1	±0.1	±0.1
4.8	±0.1	±0.1	±0.1
4.9	±0.1	±0.1	±0.1
5.0	±0.1	±0.1	±0.1

5. Block Diagram

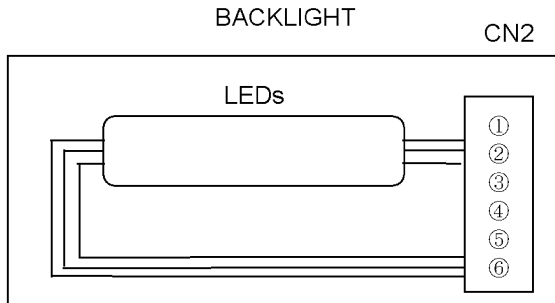
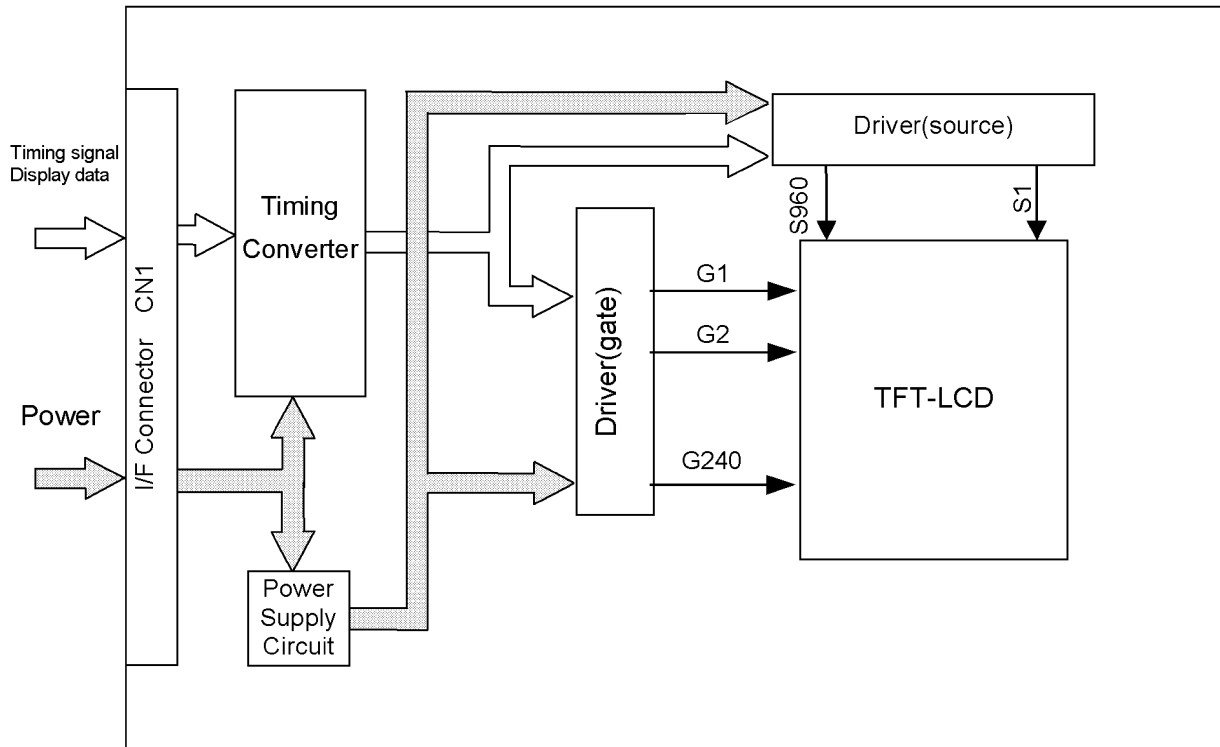

6.I/O Terminal

6.1.CN1 Pin Assignment (INTERFACE SIGNAL)

Used connector 08-6210-033(ELCO)

Corresponding FPC: P0.5, 33pin, t=0.3mm

No.	Symbol	Functional Discription
1	GND	Power Supply (0V, GND)
2	CK	Clock Signal
3	HSYC	Horizontal Sync Input
4	VSYC	Vertical Sync Input
5	GND	Power Supply (0V, GND)
6	R0	Red Data Signal
7	R1	Red Data Signal
8	R2	Red Data Signal
9	R3	Red Data Signal
10	R4	Red Data Signal
11	R5	Red Data Signal
12	GND	Power Supply (0V, GND)
13	G0	Green Data Signal
14	G1	Green Data Signal
15	G2	Green Data Signal
16	G3	Green Data Signal
17	G4	Green Data Signal
18	G5	Green Data Signal
19	GND	Power Supply (0V, GND)
20	B0	Blue Data Signal
21	B1	Blue Data Signal
22	B2	Blue Data Signal
23	B3	Blue Data Signal
24	B4	Blue Data Signal
25	B5	Blue Data Signal
26	GND	Power Supply (0V, GND)
27	ENAB	Input Data Enable Control
28	VCC(3.3V)	Power Supply for Logic
29	VCC(3.3V)	Power Supply for Logic
30	R/L	Control the shift direction of device internal shift resister
31	U/D	Set the Up/Down scan direction
32	NC	Non Connection
33	GND	Power Supply (0V, GND)

6.2.CN2 Pin Assignment (Backlight)

Used connector : SHLP-06V-S-B(JST)

Corresponding connector : SM06B-SHLS-TF(JST)

No.	Symbol	Functional Discription
1	Anode 1	LED Anode Terminal
2	Anode 2	LED Anode Terminal
3	Anode 3	LED Anode Terminal
4	Cathode 1	LED Cathode Terminal
5	Cathode 2	LED Cathode Terminal
6	Cathode 3	LED Cathode Terminal

7. Electrical Specifications

7.1. Absolute Maximum Ratings

Ta=-20~70°C, VSS=0V

Parameter	Symbol	Conditions	Min.	Max.	Units
Supply Voltage for LCD	VCC	-	-0.3	+7.0	V

7.2. DC Characteristics

Ta=-20~70°C, VSS=0V

Parameter	Symbol	Min.	Typ.	Max.	Units
Supply Voltage for LCD	VCC	3.0	3.3	3.6	V
High Level Input Voltage	V _{IH}	0.7VCC	-	VCC	V
Low Level Input Voltage	V _{IL}	0	-	0.3VCC	V
Power Supply Current for LCD	ICC	-	100	150	mA

A) Typical current condition

All black pattern with frame 240 line mode.

VCC=+3.3V, f_H=15.7kHz, f_V=60Hz, f_{CLK}=6.4MHz

7.3.AC Characteristics

7.3.1.Digital Parallel RGB Interface Timing

Ta=-20~70°C, VCC=3.0~3.6V

Parameter	Symbol	Min.	Typ.	Max.	Units
CK Frequency	1/tosc	-	6.4	-	MHz
CK Period	tosc	-	156	-	ns
CK High Pulse Width Time	toscH	12	-	-	ns
CK Low Pulse Width Time	toscL	12	-	-	ns
CK Pulse Duty ratio	toscH/ tosc	-	50	-	%
Data Setup time	tds	12	-	-	ns
Data Hold time	tdh	12	-	-	ns
HSYC (Horizontal Sync.) Signal Cycle	TH	-	62.8	-	μs
		-	408	450	clk
HSYC Pulse Width	THs	5	30	-	clk
Horizontal Display Term	THd	-	320	-	clk
ENAB Setup Time	tens	12	-	-	ns
ENAB Hold Time	tenh	12	-	-	ns
VSYC (Vertical Sync.) Signal Cycle	TV	-	262	350	Line
VSYC Pulse Width	TVs	1	3	5	Line
Vertical Display Term	TVd	-	240	-	Line
Vertical Display Start	TVds	-	18	-	Line
HSYC-ENAB Phase Difference	THE	-	68	-	clk
HSYC-CK Phase Difference	THC	12	-	-	ns
HSYC-VSYC Phase Difference	THV	1	-	-	clk

7.3.2. Input Signal Timing

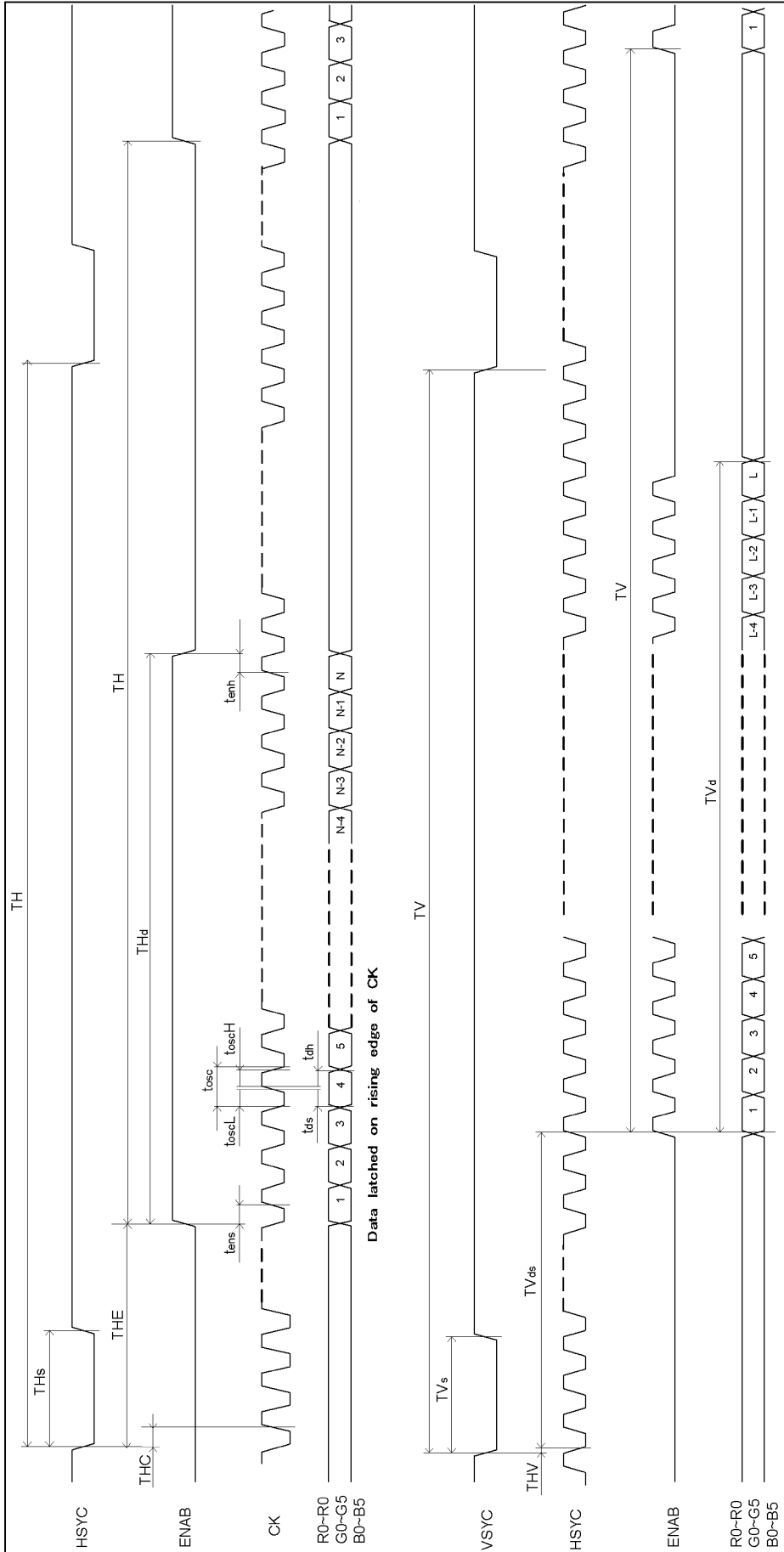

7.4.Pixel Alignment

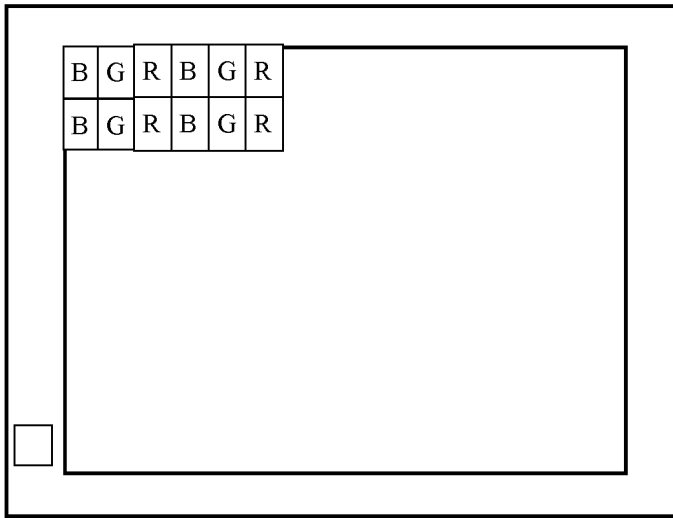

7.5.Color Data Assignment

COLOR	INPUT DATA	R DATA						G DATA						B DATA					
		MSB			LSB			MSB			LSB			MSB			LSB		
		R5	R4	R3	R2	R1	R0	G5	G4	G3	G2	G1	G0	B5	B4	B3	B2	B1	B0
BASIC COLOR	BLACK	0	0	0	0	0	0	0	0	0	0	0	0	0	0	0	0	0	0
	RED (63)	1	1	1	1	1	1	0	0	0	0	0	0	0	0	0	0	0	0
	GREEN (63)	0	0	0	0	0	0	1	1	1	1	1	1	0	0	0	0	0	0
	BLUE (63)	0	0	0	0	0	0	0	0	0	0	0	0	1	1	1	1	1	1
	CYAN	0	0	0	0	0	0	1	1	1	1	1	1	1	1	1	1	1	1
	MAGENTA	1	1	1	1	1	1	0	0	0	0	0	0	1	1	1	1	1	1
	YELLOW	1	1	1	1	1	1	1	1	1	1	1	1	0	0	0	0	0	0
	WHITE	1	1	1	1	1	1	1	1	1	1	1	1	1	1	1	1	1	1
RED	RED (0)	0	0	0	0	0	0	0	0	0	0	0	0	0	0	0	0	0	0
	RED (1)	0	0	0	0	0	1	0	0	0	0	0	0	0	0	0	0	0	0
	RED (2)	0	0	0	0	1	0	0	0	0	0	0	0	0	0	0	0	0	0
	RED (62)	1	1	1	1	1	0	0	0	0	0	0	0	0	0	0	0	0	0
	RED (63)	1	1	1	1	1	1	0	0	0	0	0	0	0	0	0	0	0	0
GREEN	GREEN (0)	0	0	0	0	0	0	0	0	0	0	0	0	0	0	0	0	0	0
	GREEN (1)	0	0	0	0	0	0	0	0	0	0	0	1	0	0	0	0	0	0
	GREEN (2)	0	0	0	0	0	0	0	0	0	0	1	0	0	0	0	0	0	0
	GREEN (62)	0	0	0	0	0	0	1	1	1	1	1	0	0	0	0	0	0	0
	GREEN (63)	0	0	0	0	0	0	1	1	1	1	1	1	0	0	0	0	0	0
BLUE	BLUE (0)	0	0	0	0	0	0	0	0	0	0	0	0	0	0	0	0	0	0
	BLUE (1)	0	0	0	0	0	0	0	0	0	0	0	0	0	0	0	0	0	1
	BLUE (2)	0	0	0	0	0	0	0	0	0	0	0	0	0	0	0	0	1	0
	BLUE (62)	0	0	0	0	0	0	0	0	0	0	0	0	1	1	1	1	1	0
	BLUE (63)	0	0	0	0	0	0	0	0	0	0	0	0	1	1	1	1	1	1

[Note]

- 1) Definition of gray scale
Color (n) --- n indicates gray scale level.
Higher n means brighter level.

2) Data 1:High, 0: Low

Relation of IC and LCD Module Data Bus

LCD Module	RGB5	RGB4	RGB3	RGB2	RGB1	RGB0	*	*
IC	RGB7	RGB6	RGB5	RGB4	RGB3	RGB2	RGB1	RGB0

*Connected to "L" in the LCD Module

7.6. Inverted Scan Capability

This module has the capability of inverting scan direction by signaling from controller. Note that scan direction cannot be changed during operation.

The following drawing shows the relationship between the viewing direction and the scan direction.

Normal scan(U/D:H R/L:L)

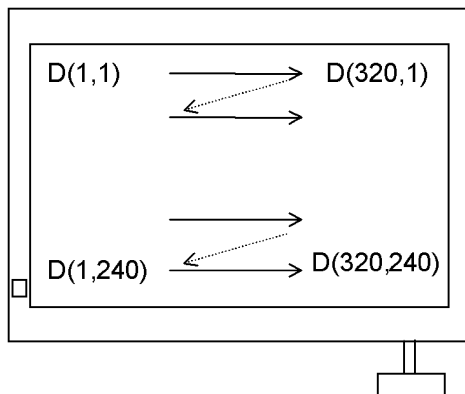

Reverse scan(U/D:L R/L:H)

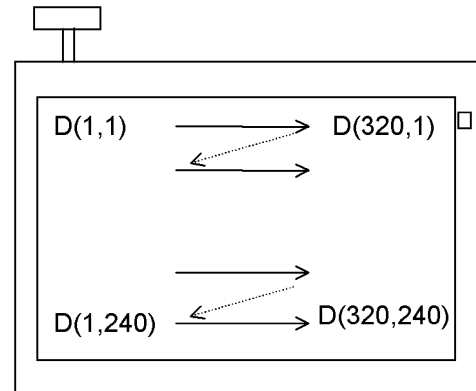

7.7. Lighting Specifications

7.7.1. Absolute Maximum Ratings

Ta=25°C

Parameter	Symbol	Conditions	Min.	Typ.	Max.	Units
Foward Current	I _F	Note 1, 2	-	-	90	mA
Reverse Voltage	V _R	Note 1	-	-	20	V
LED Power Dissipation	P _D	Note 1	-	-	1.6	W

Note 1 : This value is for each 1 line.

Note 2 : Refer to the foward current derating curve.

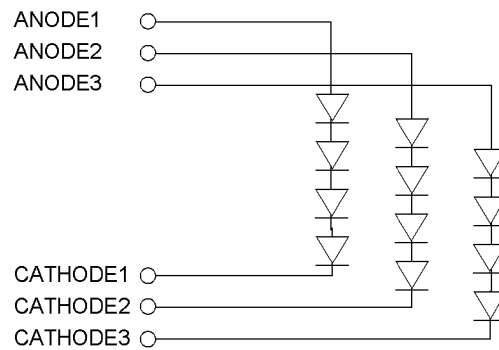
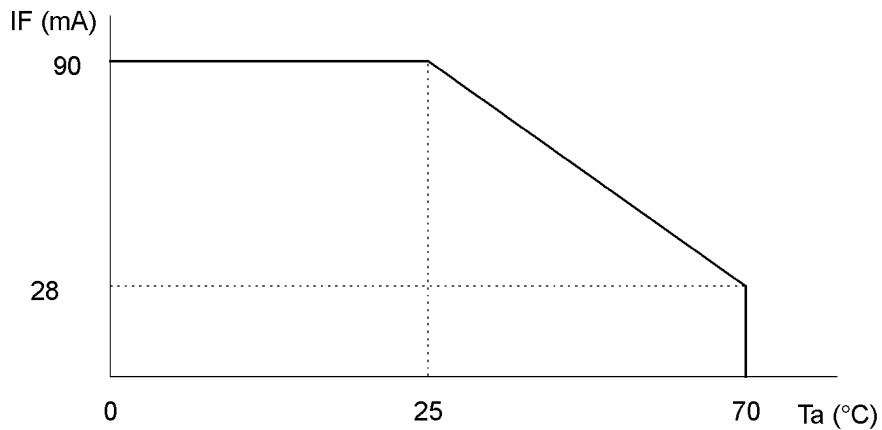

7.7.2. Operating Characteristics

Ta=25°C

Parameter	Symbol	Conditions	Min.	Typ.	Max.	Units
Foward Voltage	V _F	I _F =60mA / 1 line	-	(13.2)	-	V

8. Optical Specifications

8.1. Optical Characteristics

Item	Symbol	Conditions			Standard Value			Unit	Method of Measure	Remark	
		θ	ϕ	C	Min.	Typ.	Max.				
Brightness	B	0°	0°	/	350	500	-	cd/m ²	(Fig.1)	Note1	
Contrast	CR	Best Viewing			210	350	-	-			
Color Coordinates	Red	Rx	0°	0°	/	0.580	0.630	0.680			-
		Ry	0°	0°	/	0.300	0.350	0.400			-
	Green	Gx	0°	0°	/	0.260	0.310	0.360			-
		Gy	0°	0°	/	0.540	0.590	0.640			-
	Blue	Bx	0°	0°	/	0.090	0.140	0.190			-
		By	0°	0°	/	0.070	0.120	0.170			-
White	Wx	0°	0°	/	0.270	0.320	0.370	-			
	Wy	0°	0°	/	0.310	0.360	0.410	-			
Brightness Uniformity	-	0°	0°	/	70	75	-	%	(Fig.2)		
Vertical Viewing Angle	Up	θ_U	-	0°	≥ 5	-	70	-	Degree	(Fig.3)	
	Down	θ_D	-	0°	≥ 5	-	70	-	Degree		
Horizontal Viewing Angle	Left	ϕ_L	0°	-	≥ 5	-	70	-	Degree		
	Right	ϕ_R	0°	-	≥ 5	-	70	-	Degree		
Response Time	Rise	τ_r	0°	0°	/	-	21	-	ms	(Fig.4)	
	Decay	τ_d	0°	0°	/	-	10	-	ms		

Note1: Under the condition of maximum brightness.

- ◆ Conditions for Measuring
 - ◇ Environment: Dark room with no light or close to no light.
 - ◇ Temperature: 25±5°C
 - ◇ Humidity: 40~70%RH
 - ◇ Driving voltage is set for optimal contrast to measure center of display.
 - ◇ LED Backlight driving condition: IF=60mA/1Line
- ◆ Optimal viewing angle
(The angle of Least Color Inversion)

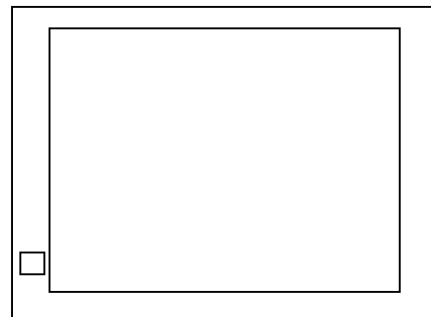



6 O'clock

8.2. Definition of Viewing Angle and Optimum Viewing Area

*Point ● shows the point where contrast ratio is measured. : $\theta = 0^\circ$, $\phi = -0^\circ$

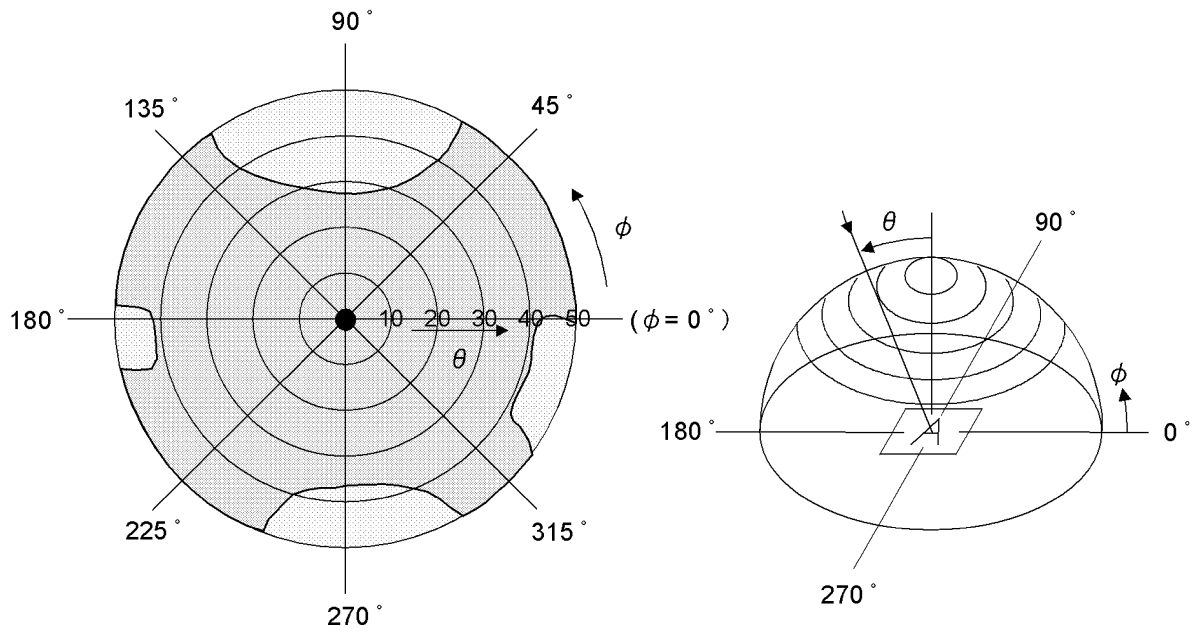
*Driving condition: $F_r = 60\text{Hz}$



*Area  shows typ. $CR \geq 5$

*Area  shows typ. $CR \geq 20$

◆ Method of Brightness Measurement (Fig.1)

(1) Measuring Device

TOPCON: BM-5

(2) Measuring Point

Center of Display: $\theta=0^\circ$, $\phi=0^\circ$

On condition θ : A vertical angle from measuring direction to perpendicular.

ϕ : A horizontal angle from measuring direction to perpendicular.

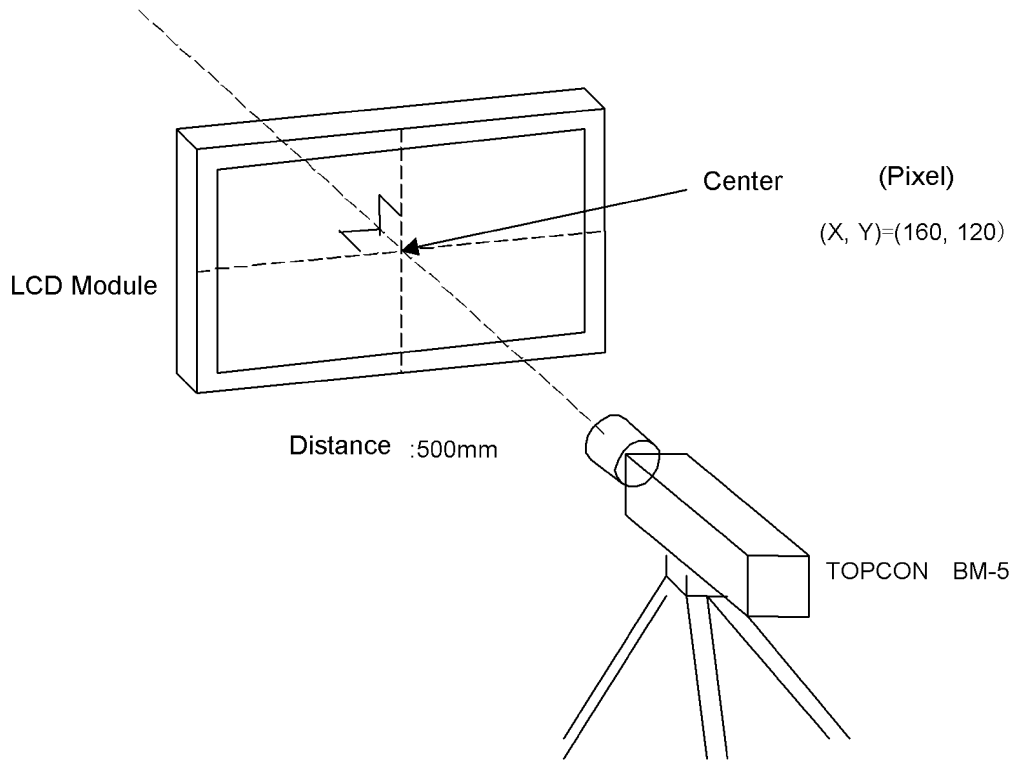

Fig. 1

(3) Method of Measuring

Apply signal voltage (displayed in white) to maximize brightness and measure brightness B (cd/m^2).

The distance between BM-5's front lens to surface panel is 500mm.

Measured after backlight has been lit for more than 30 minutes.

◆ Method of Contrast Measurement (Fig.1)

(1) Measuring Device

TOPCON: BM-5, Measuring Field: 1°

(2) Measuring Point

Center of display: same as Method of Brightness Measurement

(3) Method of Measuring

- Set LCD module to $\theta=0^\circ$, $\phi=0^\circ$.
- Change signal voltage to measure maximum brightness $Y1$ and minimum brightness $Y2$.
- Contrast is derived from $CR=Y1/Y2$.

◆ Definition of Brightness Uniformity (Fig.2)

Definition is calculated from the four points (S1-S9) on the diagram below.

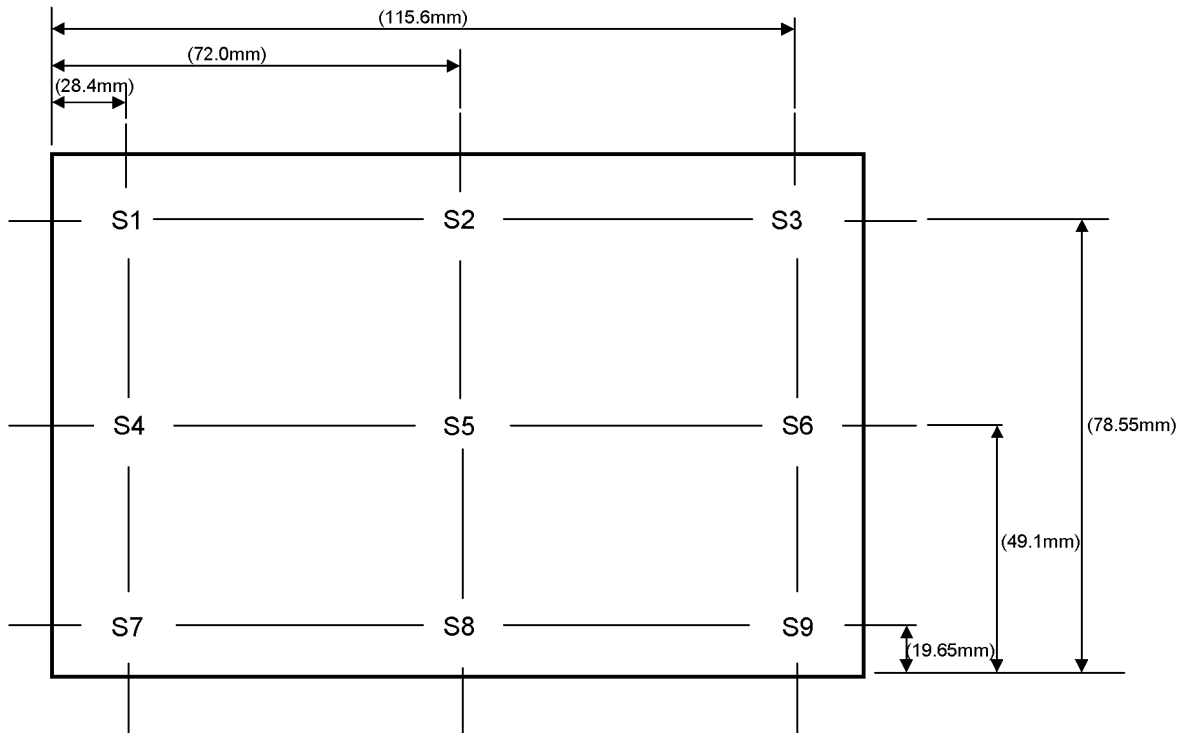

$$\text{Standard Value of Brightness Uniformity [\%]} = \frac{\text{Minimum Value of S1-S9}}{\text{Maximum Value of S1-S9}} \times 100$$

Fig. 2

◆ Method of Viewing Angle Measurement (Fig.3)

(1) Measuring Device

ELDIM: EZ CONTRAST

(2) Measuring Point

Center of display: Same as Method of Brightness Measurement

(3) Angle of Measuring

θ : An angle vertical to perpendicular line from the viewing direction.

ϕ : An angle horizontal to perpendicular from the viewing direction.

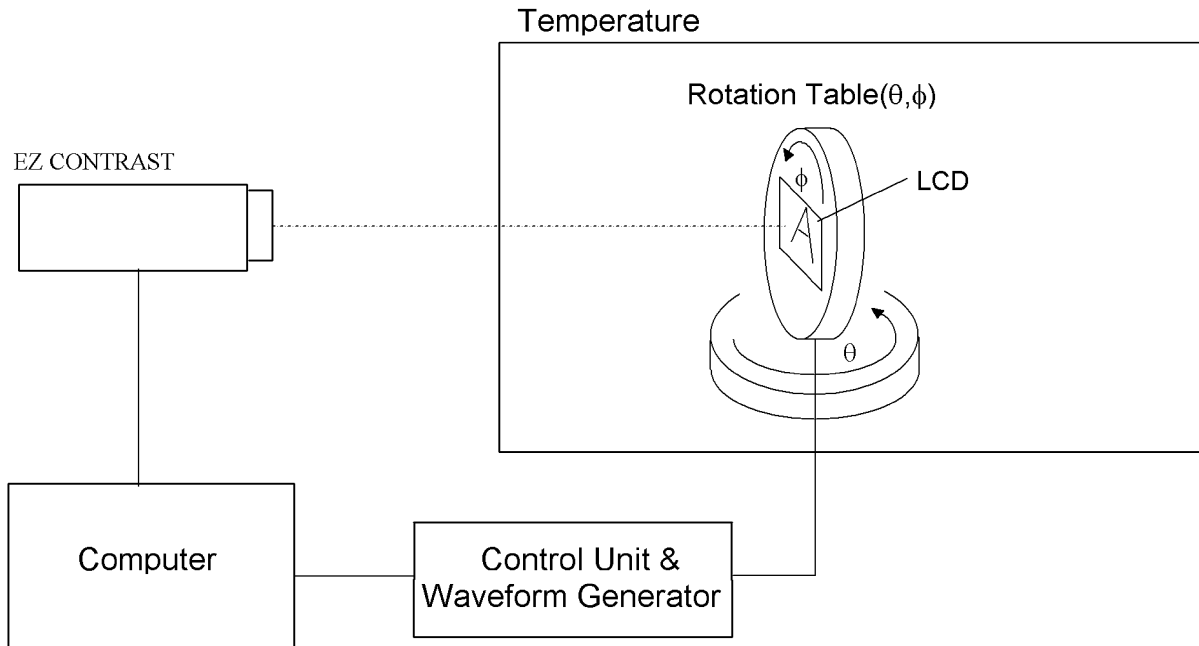

Fig. 3

(4) Method of Measuring

Set the module on the rotation table and measure a vertical axis direction in the state that fixed $\phi = 0$ degrees horizontal axis direction to $\theta = 90$ degrees.

(Viewing angle is measured automatically by EZ CONTRAST)

◆ Measuring Response Time (Fig.4)

(1) Measuring Device

TOPCON BM-5, Measuring Field: 1°

Tektronix Digital Oscilloscope

(2) Measuring Point

Center of display, same as Method of Brightness Measurement

(3) Method of Measuring

- Set LCD panel to $\theta=0^\circ$, and $\phi=0^\circ$.
- Input white→black→white to display by switching signal voltage.
- If the luminance is 0% and 100% immediately before the change of signal voltage, then τ_r is optical response time during the change from 90% to 10% immediately after rise of signal voltage, and τ_d is optical response time during the change from 10% to 90% immediately after decay of signal voltage.

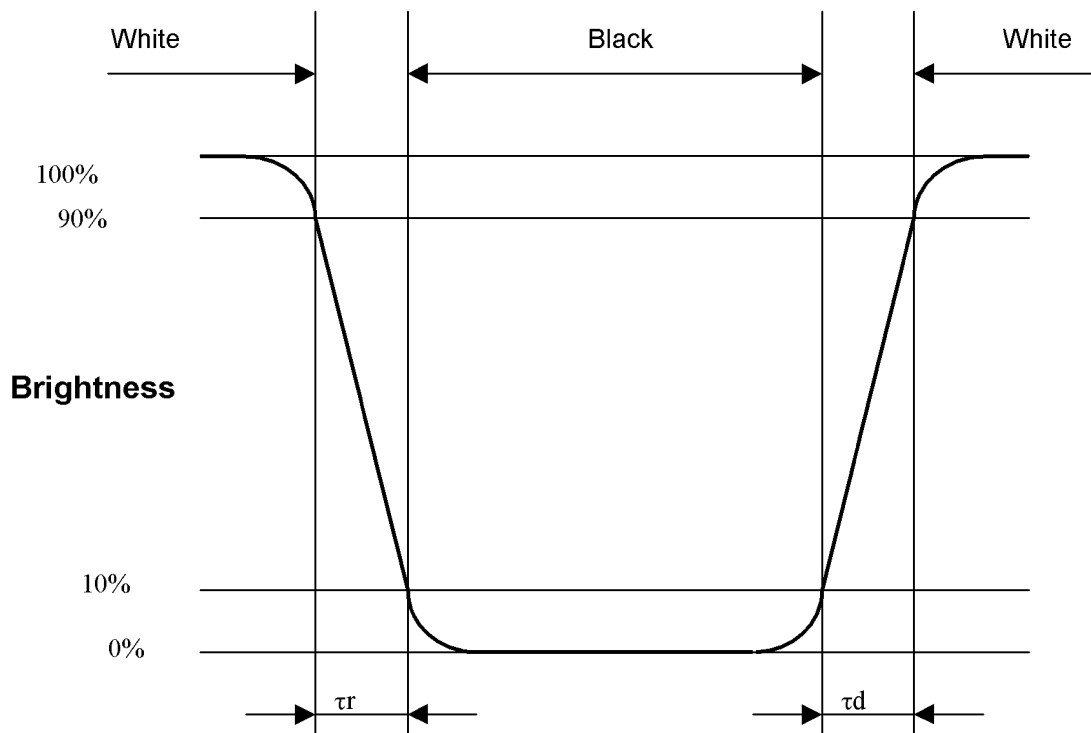

Fig. 4

9. Test

No abnormal function and appearance are found after the following tests.

Conditions: Unless otherwise specified, tests will be conducted under the following condition.

Temperature: $20 \pm 5^\circ\text{C}$

Humidity : $65 \pm 5\% \text{RH}$

tests will not be conducted under functioning state.

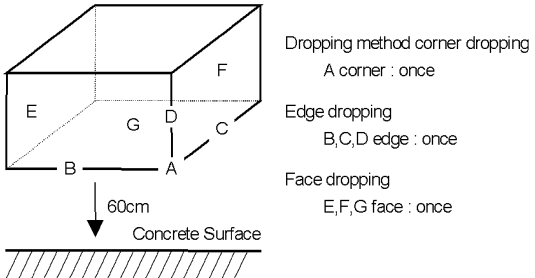
No.	Parameter	Conditions	Notes
1	High Temperature Operating	$70^\circ\text{C} \pm 2^\circ\text{C}$, 96hrs (operation state)	
2	Low Temperature Operating	$-20^\circ\text{C} \pm 2^\circ\text{C}$, 96hrs (operation state)	1
3	High Temperature Storage	$80^\circ\text{C} \pm 2^\circ\text{C}$, 96hrs	2
4	Low Temperature Storage	$-30^\circ\text{C} \pm 2^\circ\text{C}$, 96hrs	1,2
5	Damp Proof Test	$40^\circ\text{C} \pm 2^\circ\text{C}$, 90~95%RH, 96hrs	1,2
6	Vibration Test	Total fixed amplitude : 1.5mm Vibration Frequency : 10~55Hz One cycle 60 seconds to 3 directions of X, Y, Z each 15 minutes	3
7	Shock Test	To be measured after dropping from 60cm high the concrete surface in packing state. 	

Note 1 :No dew condensation to be observed.

Note 2 :The function test shall be conducted after 4 hours storage at the normal Temperature and humidity after removed from the test chamber.

Note 3 :Vibration test will be conducted to the product itself without putting it in a container.

10. Appearance Standards

10.1. Inspection conditions

The LCD shall be inspected under the white fluorescent light.

Appearance Inspection: Illuminans > 500 [lx]

Operating Inspection: Illuminance < 250 [lx]

The distance between the eyes and the sample shall be more than 30cm.

All directions for inspecting the sample should be within 45° against perpendicular line.

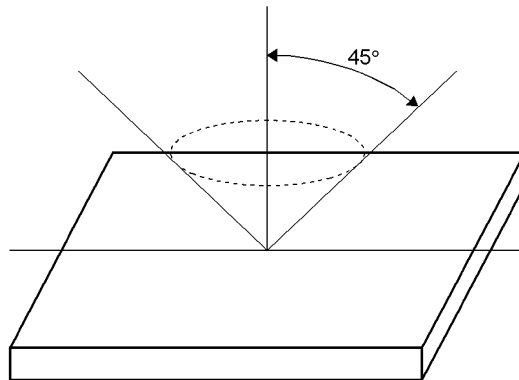

10.2. Definition of applicable Zones

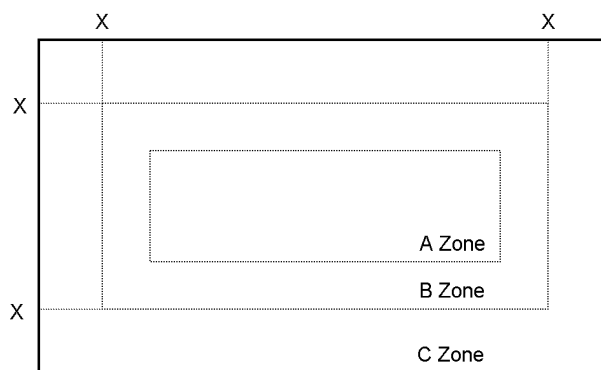

X : Metal Holder Opening

A Zone: Active display area

B Zone = (Viewing Area) – (Active Area)

C Zone: Rest parts

10.3.Standards

No.	Parameter	Criteria																												
1	Polarizer Scratches	<table border="1"> <thead> <tr> <th colspan="2" rowspan="2">Zone</th> <th colspan="3">Acceptable Number</th> </tr> <tr> <th>A</th> <th>B</th> <th>C</th> </tr> </thead> <tbody> <tr> <td>X(mm) \ Y(mm)</td> <td></td> <td></td> <td></td> <td></td> </tr> <tr> <td>L ≤ 15</td> <td>0.01 < W ≤ 0.05</td> <td colspan="2">4</td> <td>*</td> </tr> <tr> <td>L > 15</td> <td>W > 0.01</td> <td colspan="2">0</td> <td>*</td> </tr> <tr> <td>-</td> <td>W > 0.05</td> <td colspan="2">0</td> <td>*</td> </tr> </tbody> </table> <p>X : Length, Y : Width * : Disregard</p>	Zone		Acceptable Number			A	B	C	X(mm) \ Y(mm)					L ≤ 15	0.01 < W ≤ 0.05	4		*	L > 15	W > 0.01	0		*	-	W > 0.05	0		*
Zone		Acceptable Number																												
		A	B	C																										
X(mm) \ Y(mm)																														
L ≤ 15	0.01 < W ≤ 0.05	4		*																										
L > 15	W > 0.01	0		*																										
-	W > 0.05	0		*																										
2	DENT	<table border="1"> <thead> <tr> <th colspan="2" rowspan="2">Zone</th> <th colspan="3">Acceptable Number</th> </tr> <tr> <th>A</th> <th>B</th> <th>C</th> </tr> </thead> <tbody> <tr> <td colspan="2">Dimension (mm)</td> <td></td> <td></td> <td></td> </tr> <tr> <td colspan="2">0.30 < D ≤ 0.50</td> <td colspan="2">4</td> <td>*</td> </tr> <tr> <td colspan="2">0.50 < D</td> <td colspan="2">0</td> <td>*</td> </tr> </tbody> </table> <p>D : Average Diameter = (long+short)/2 * : Disregard</p>	Zone		Acceptable Number			A	B	C	Dimension (mm)					0.30 < D ≤ 0.50		4		*	0.50 < D		0		*					
Zone		Acceptable Number																												
		A	B	C																										
Dimension (mm)																														
0.30 < D ≤ 0.50		4		*																										
0.50 < D		0		*																										
3	BLACK SPOT WHITE SPOT BUBBLE	<table border="1"> <thead> <tr> <th colspan="2" rowspan="2">Zone</th> <th colspan="3">Acceptable Number</th> </tr> <tr> <th>A</th> <th>B</th> <th>C</th> </tr> </thead> <tbody> <tr> <td colspan="2">Dimension (mm)</td> <td></td> <td></td> <td></td> </tr> <tr> <td colspan="2">0.30 < D ≤ 0.50</td> <td colspan="2">5</td> <td>*</td> </tr> <tr> <td colspan="2">0.50 < D</td> <td colspan="2">0</td> <td>*</td> </tr> </tbody> </table>	Zone		Acceptable Number			A	B	C	Dimension (mm)					0.30 < D ≤ 0.50		5		*	0.50 < D		0		*					
Zone		Acceptable Number																												
		A	B	C																										
Dimension (mm)																														
0.30 < D ≤ 0.50		5		*																										
0.50 < D		0		*																										
4	LINT	<table border="1"> <thead> <tr> <th colspan="2" rowspan="2">Zone</th> <th colspan="3">Acceptable Number</th> </tr> <tr> <th>A</th> <th>B</th> <th>C</th> </tr> </thead> <tbody> <tr> <td>X(mm) \ Y(mm)</td> <td></td> <td></td> <td></td> <td></td> </tr> <tr> <td>L ≤ 3.0</td> <td>W ≤ 0.15</td> <td colspan="2">4</td> <td>*</td> </tr> <tr> <td>L > 3.0</td> <td>W ≤ 0.15</td> <td colspan="2">0</td> <td>*</td> </tr> <tr> <td>-</td> <td>W > 0.15</td> <td colspan="2">According to BLACK SPOT</td> <td>*</td> </tr> </tbody> </table> <p>X : Length, Y : Width * : Disregard</p>	Zone		Acceptable Number			A	B	C	X(mm) \ Y(mm)					L ≤ 3.0	W ≤ 0.15	4		*	L > 3.0	W ≤ 0.15	0		*	-	W > 0.15	According to BLACK SPOT		*
Zone		Acceptable Number																												
		A	B	C																										
X(mm) \ Y(mm)																														
L ≤ 3.0	W ≤ 0.15	4		*																										
L > 3.0	W ≤ 0.15	0		*																										
-	W > 0.15	According to BLACK SPOT		*																										

No.	Parameter	Criteria																							
5	(a) Bright Dot (b) Dark Dot	<table border="1"> <thead> <tr> <th colspan="2" rowspan="2">Zone</th> <th colspan="3">Acceptable Number</th> </tr> <tr> <th>A</th> <th>B</th> <th>C</th> </tr> </thead> <tbody> <tr> <td>Bright Dot</td> <td>Note1</td> <td colspan="2">4</td> <td>*</td> </tr> <tr> <td>Dark Dot</td> <td>Note2</td> <td colspan="2">5</td> <td>*</td> </tr> <tr> <td colspan="2">TOTAL</td> <td colspan="3">5</td> </tr> </tbody> </table>	Zone		Acceptable Number			A	B	C	Bright Dot	Note1	4		*	Dark Dot	Note2	5		*	TOTAL		5		
	Zone				Acceptable Number																				
			A	B	C																				
	Bright Dot	Note1	4		*																				
Dark Dot	Note2	5		*																					
TOTAL		5																							
(c) TWO Adjacent Dot	<table border="1"> <thead> <tr> <th colspan="2" rowspan="2">Zone</th> <th colspan="3">Acceptable Number</th> </tr> <tr> <th>A</th> <th>B</th> <th>C</th> </tr> </thead> <tbody> <tr> <td>Bright Dot</td> <td>Note1,3</td> <td colspan="2">2 PAIRS</td> <td>*</td> </tr> <tr> <td>Dark Dot</td> <td>Note2,3</td> <td colspan="2">3 PAIRS</td> <td>*</td> </tr> </tbody> </table>	Zone		Acceptable Number			A	B	C	Bright Dot	Note1,3	2 PAIRS		*	Dark Dot	Note2,3	3 PAIRS		*						
Zone				Acceptable Number																					
		A	B	C																					
Bright Dot	Note1,3	2 PAIRS		*																					
Dark Dot	Note2,3	3 PAIRS		*																					
(d) Three or More Adjacent Dot	NOT ALLOWED																								
(e) Distance	<table border="1"> <thead> <tr> <th colspan="2" rowspan="2">Zone</th> <th colspan="3">Acceptable Level</th> </tr> <tr> <th>A</th> <th>B</th> <th>C</th> </tr> </thead> <tbody> <tr> <td>Bright Dot</td> <td></td> <td colspan="2">5 mm \leq</td> <td>*</td> </tr> <tr> <td>Dark Dot</td> <td></td> <td colspan="2">5 mm \leq</td> <td>*</td> </tr> </tbody> </table>	Zone		Acceptable Level			A	B	C	Bright Dot		5 mm \leq		*	Dark Dot		5 mm \leq		*						
Zone				Acceptable Level																					
		A	B	C																					
Bright Dot		5 mm \leq		*																					
Dark Dot		5 mm \leq		*																					
6	Line Defect	NOT ALLOWED																							

Note 1: Bright Dot is defined as follows:

Visible through 5% transmission ND filter under the condition that black image (color 0) is on the display.

Note 2: Dark Dot is defined as follows:

Recognizable darker than around under the condition that each R(63), G(63), B(63) image is on the display.

Note 3: Definition of adjacent

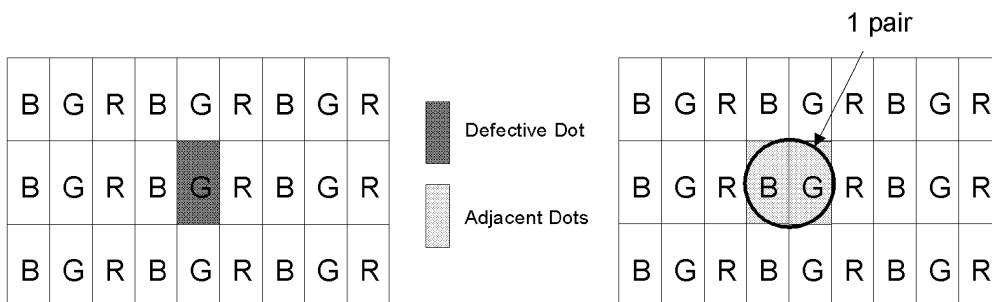

11.Code System of Production Lot

The production lot of module is specified as follows.

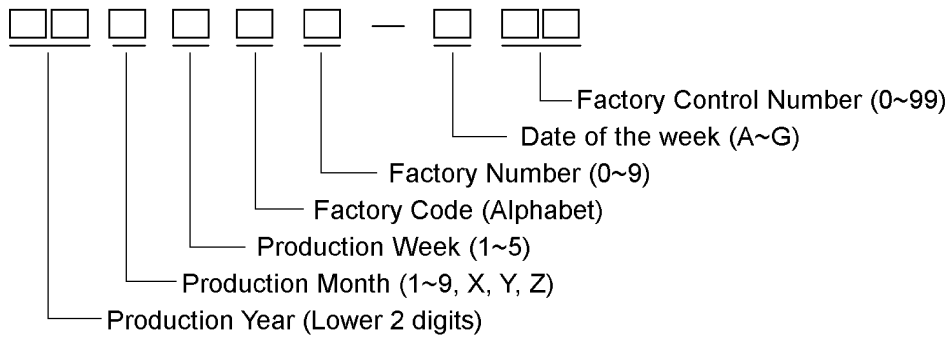

12.Type Number

The type number of module is specified as follows.

355265AB

13.Applying Precautions

Please contact us when questions and/or new problems not specified in this Specifications arise.