



Chipsmall Limited consists of a professional team with an average of over 10 year of expertise in the distribution of electronic components. Based in Hongkong, we have already established firm and mutual-benefit business relationships with customers from,Europe,America and south Asia,supplying obsolete and hard-to-find components to meet their specific needs.

With the principle of “Quality Parts,Customers Priority,Honest Operation,and Considerate Service”,our business mainly focus on the distribution of electronic components. Line cards we deal with include Microchip,ALPS,ROHM,Xilinx,Pulse,ON,Everlight and Freescale. Main products comprise IC,Modules,Potentiometer,IC Socket,Relay,Connector.Our parts cover such applications as commercial,industrial, and automotives areas.

We are looking forward to setting up business relationship with you and hope to provide you with the best service and solution. Let us make a better world for our industry!



## Contact us

Tel: +86-755-8981 8866 Fax: +86-755-8427 6832

Email & Skype: info@chipsmall.com Web: www.chipsmall.com

Address: A1208, Overseas Decoration Building, #122 Zhenhua RD., Futian, Shenzhen, China



# LCD Module Technical Specification

液晶表示モジュール仕様書

First Edition 初版作成

May. 26, 2016

Final Revision 最終改訂

Type No. **T-55619GD065J-LW-ABN**

Customer : **STANDARD /スタンダード**

Customer's Product No : -----

## KYOCERA Display Corporation

Approved: 

Checked: 

Prepared: 

**APPROVED**

By

Signature :

Date :

Please return this specification within two month with your signature.  
If not returned within two month, specification will be considered  
as having been accepted.

受領印ご押印の上、作成日から2ヶ月以内に、弊社担当者までご返却ください。  
ご返却なき場合は、問題ないものとして取り扱い処理させていただきます。

## Table of Contents (目次)

1. Application (適用) .....	3
2. General Specifications (一般仕様) .....	3
3. Operating Conditions (環境条件) .....	4
4. Dimensional Outline (外観図) .....	5
5. Block Diagram (ブロック図) .....	6
6. I/O Terminal (I/O端子) .....	7
7. Electrical Specifications (電氣的仕様) .....	9
8. Optical Specifications (光学仕様) .....	16
9. Test (試験) .....	21
10. Appearance Standards (外観規格) .....	23
11. Code System of Production Lot (製造ロット番号) .....	27
12. Type Number (製品型式) .....	27
13. Applying Precautions (運用上の注意) .....	27
14. Precautions Relating Product Handling (製品取扱い上の注意) .....	28
15. Warranty (保証条件) .....	31

## Revision History (改訂履歴)

Rev.(改版)	Date(改訂日)	Page(ページ)	Comment (内 容)

## 1. Application (適用)

This specification applies to TFT-LCD module (T-55619GD065J-LW-ABN).

弊社仕様書は、弊社が製造する TFT-LCD モジュール  
(品番 : T-55619GD065J-LW-ABN) に適用する。

## 2. General Specifications (一般仕様)

Resolution (画素数)	: 640 x 3 [R.G.B] (W) x 480 (H) dots
Dot pitch (ドットピッチ)	: 0.069 x 3 [R.G.B] (W) x 0.207 (V) mm
Pixel arrangement (画素配列)	: RGB-Stripe
Color depth (色数)	: 262,144 colors
Active Viewing Area (有効視野範囲)	: 132.5 (W) x 99.4 (H) mm
Outline dimensions * (外形寸法)	: 158.0 (W) x 120.36 (H) x 10.5 (D) mm * Excluding backlight cables.(バックライトケーブルを含まない)
Weight (重量)	: 230g max.
LCD type (LCD タイプ)	: ATS-22174 TFT / Normally white-mode / Transmissive (TFT / ノーマリーホワイト / 透過型)
Viewing angle (視角)	: 6:00
Surface Treatment (表面処理)	: AG Coating
Interface (データ転送方式)	: LVDS (Low Voltage Differential Signaling) (小振幅差動信号方式)
Backlight (照明仕様)	: LED Backlight / White (LED バックライト / 白色)
Lead free (鉛フリー)	: Our product corresponds to lead free. Lead free is defined as below: 1) The solder used in the LCD module. 2) Electrical components (Terminal section) used in the LCD module. Any lead used within the electrical component does not apply to our module definition of lead free. 本製品は、鉛フリーに対応しております。 当社の鉛フリーの定義は以下の通りです。 (1) 液晶モジュールに使用している「半田」 (2) 液晶モジュールに使用している「電子部品(端子部分)」 但し、電子部品内部に含まれている鉛は対象外とします。

RoHS regulation  
(RoHS 規定)

: To our best knowledge, this product satisfies material requirement of RoHS regulation.

Our company is doing the best efforts to obtain the equivalent certificate from our suppliers.

: 当社の認知する限りにおいて、本製品は RoHS 規定の主要要件を満たしていると認識しております。  
当社としては、部材メーカー等に対して同様の保証を求めべく最大限の努力を行っております。

### 3. Operating Conditions (環境条件)

Item (項目)	Conditions (条件)	Temperature Range (温度範囲)	Remark (備考)
Operating Temperature Range (動作温度範囲)	PNL Surface (パネル表面)	-20~70°C	Note1 (注1)
Storage Temperature Range (保存温度範囲)	PNL Surface (パネル表面)	-20~70°C	

Note1: Operating temperature range defines the operation only and the contrast, response time and other display optical characteristics are set at Ta=+25°C.

注1：動作温度範囲は、動作のみを保証する温度であり、コントラスト、応答速度、その他の表示品位、光学性能は Ta=+25°Cにて判定します。

# 4. Dimensional Outline (外觀圖)

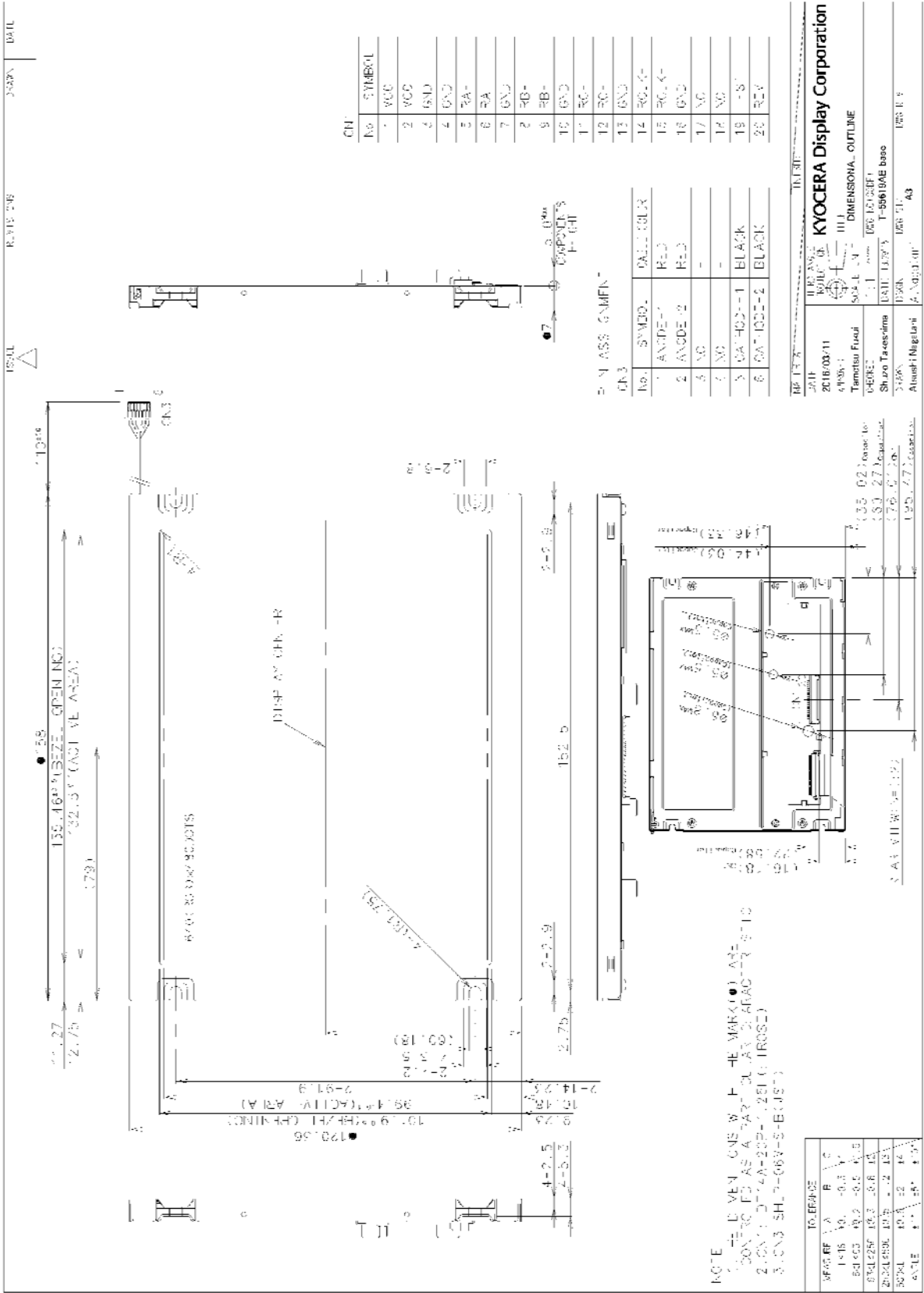

NO.	SYMBOL
1	VCC
2	VCC
4	GND
4	GND
5	TA-
6	TA
7	GND
8	FB-
9	FB
10	GND
11	RG-
12	RG
13	GND
14	RG-C
15	RG-C
16	GND
17	RG
18	RG
19	-S
20	REV

NO.	SYMBOL	DATE COLOR
1	ANODE-1	RED
2	ANODE-2	RED
3	RG	-
4	RG	-
5	GA-HD-1-1	BLACK
6	GA-HD-2-2	BLACK

REV. 248 16.1.97

DATE: 2016.08.11  
 DRAWN BY: T-55619GAE base  
 CHECKED BY: T-55619GAE base  
 NAME: DIMENSIONAL OUTLINE  
 SIZE: A3  
 SHEET: 1/1  
 DRAWING NO.: T-55619GAE base  
 DRAWN BY: T-55619GAE base  
 CHECKED BY: T-55619GAE base  
 APPROVED BY: T-55619GAE base

KYOCERA Display Corporation

NOTE: THE DIMEN. CNS WITH THE MARK (○) ARE CONTROLLED AS A FACTORY DIAGNOSTIC POINT. (D-CHECK POINT) (D-CHECK POINT) (D-CHECK POINT)

3. CNS SHL-06V-5-BUS

DIMENSION	TOLERANCE		
	A	B	C
1-15	±0.1	±0.1	±0.1
16-20	±0.2	±0.2	±0.2
21-25	±0.3	±0.3	±0.3
26-30	±0.4	±0.4	±0.4
31-35	±0.5	±0.5	±0.5
36-40	±0.6	±0.6	±0.6
41-45	±0.7	±0.7	±0.7
46-50	±0.8	±0.8	±0.8
51-55	±0.9	±0.9	±0.9
56-60	±1.0	±1.0	±1.0
61-65	±1.1	±1.1	±1.1
66-70	±1.2	±1.2	±1.2
71-75	±1.3	±1.3	±1.3
76-80	±1.4	±1.4	±1.4
81-85	±1.5	±1.5	±1.5
86-90	±1.6	±1.6	±1.6
91-95	±1.7	±1.7	±1.7
96-100	±1.8	±1.8	±1.8
101-105	±1.9	±1.9	±1.9
106-110	±2.0	±2.0	±2.0
111-115	±2.1	±2.1	±2.1
116-120	±2.2	±2.2	±2.2
121-125	±2.3	±2.3	±2.3
126-130	±2.4	±2.4	±2.4
131-135	±2.5	±2.5	±2.5
136-140	±2.6	±2.6	±2.6
141-145	±2.7	±2.7	±2.7
146-150	±2.8	±2.8	±2.8
151-155	±2.9	±2.9	±2.9
156-160	±3.0	±3.0	±3.0
161-165	±3.1	±3.1	±3.1
166-170	±3.2	±3.2	±3.2
171-175	±3.3	±3.3	±3.3
176-180	±3.4	±3.4	±3.4
181-185	±3.5	±3.5	±3.5
186-190	±3.6	±3.6	±3.6
191-195	±3.7	±3.7	±3.7
196-200	±3.8	±3.8	±3.8
201-205	±3.9	±3.9	±3.9
206-210	±4.0	±4.0	±4.0
211-215	±4.1	±4.1	±4.1
216-220	±4.2	±4.2	±4.2
221-225	±4.3	±4.3	±4.3
226-230	±4.4	±4.4	±4.4
231-235	±4.5	±4.5	±4.5
236-240	±4.6	±4.6	±4.6
241-245	±4.7	±4.7	±4.7
246-250	±4.8	±4.8	±4.8
251-255	±4.9	±4.9	±4.9
256-260	±5.0	±5.0	±5.0

Confidential

## 5. Block Diagram (ブロック図)

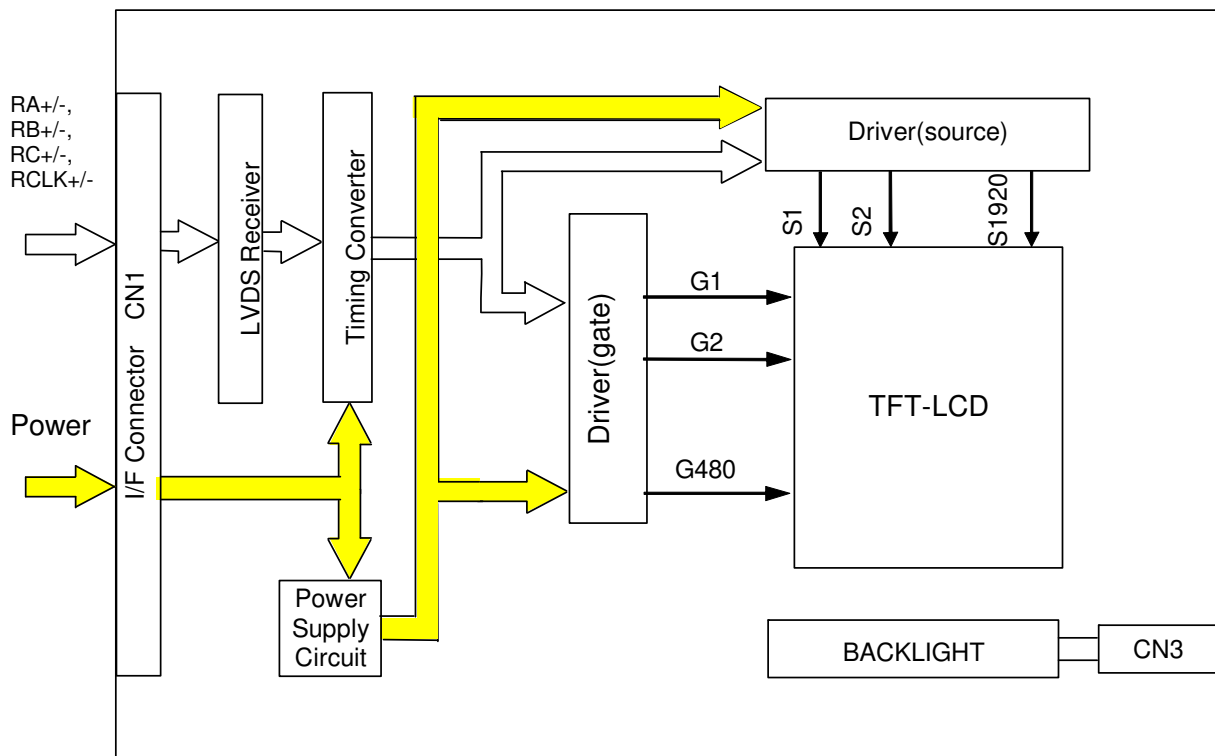

## 6. I/O Terminal ( I / O 端子 )

### 6.1. CN1 Pin Assignment (CN1 端子名)

INTERFACE SIGNAL (インターフェース信号)

Used connector(使用コネクタ): DF14A-20P-1.25H(56) (HIROSE)

Corresponding connector(適合コネクタ): DF14-20S-1.25C (HIROSE)

No.	Symbol(記号)	Functional Description (機能説明)
1	VCC	Power Supply (電源) (DC 3.3V )
2	VCC	Power Supply (電源) (DC 3.3V)
3	GND	Power Supply (電源) (0V, GND)
4	GND	Power Supply (電源) (0V, GND)
5	RA-	LVDS Data Input R0, R1, R2, R3, R4, R5, G0
6	RA+	LVDS Data Input R0, R1, R2, R3, R4, R5, G0
7	GND	Power Supply (電源) (0V, GND)
8	RB-	LVDS Data Input G1, G2, G3, G4, G5, B0, B1
9	RB+	LVDS Data Input G1, G2, G3, G4, G5, B0, B1
10	GND	Power Supply (電源) (0V, GND)
11	RC-	LVDS Data Input B2, B3, B4, B5, HD, VD, DENA
12	RC+	LVDS Data Input B2, B3, B4, B5, HD, VD, DENA
13	GND	Power Supply (電源) (0V, GND)
14	RCLK-	LVDS Clock Input
15	RCLK+	LVDS Clock Input
16	GND	Power Supply (電源) (0V, GND)
17	NC	Non Connection (未使用端子)
18	NC	Non Connection (未使用端子)
19	TEST	This pin should be open. Test signal output for only internal test use. (テスト信号出力端子(システム側でオープンにして下さい))
20	REV	Reverse scans control. L = Normal, H = Reverse (表示方向切換え。L=通常走査、H=逆走査)

Note(注): The shielding case is connected with GND (フレームは GND に接続されています。)

### 6.2. CN 3 Pin Assignment (CN3 端子名)

Used connector(使用コネクタ): SHLP-06V-S-B (JST)

Corresponding connector(適合コネクタ): SM06-SHLS-TF (LF)(SN)(JST)

No.	Symbol(記号)	Functional Description (機能説明)
1	ANODE-1(RED)	LED Anode Terminal (LED アノード端子)
2	ANODE-2(RED)	LED Anode Terminal (LED アノード端子)
3	NC	Non Connection (未使用端子)
4	NC	Non Connection (未使用端子)
5	CATHODE-1(BLACK)	LED Cathode Terminal (LED カソード端子)
6	CATHODE-2(BLACK)	LED Cathode Terminal (LED カソード端子)



### 6.3.ISP data mapping

#### a. ISP 6 bit compatibility mode (6 bit input)

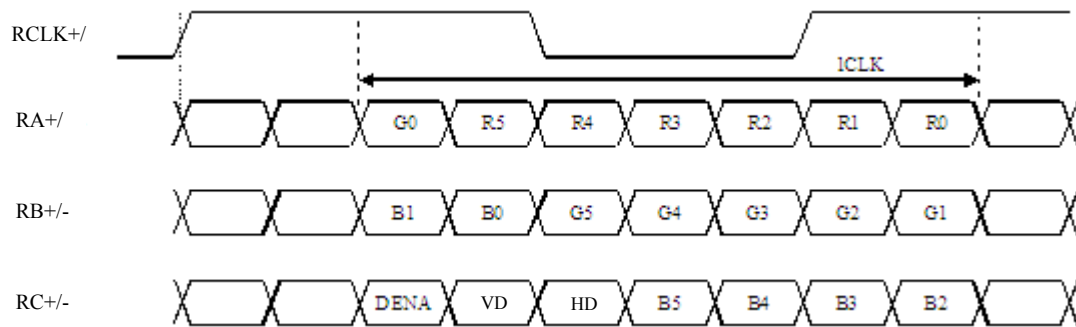

## 7. Electrical Specifications (電氣的仕様)

### 7.1. Absolute Maximum Ratings (絶対最大定格)

Ta=-20~70°C, GND=0V

Parameter (項目)	Symbol (記号)	Conditions (条件)	Min.	Max.	Units (単位)
Supply Voltage for LCD	VCC	-	0	4.0	V
Logic Input Voltage	VI	-	-0.3	4.0	V

### 7.2. DC Characteristics (DC特性)

Ta=-20~70°C, GND=0V

Parameter (項目)	Symbol (記号)	Conditions (条件)	Min.	Typ.	Max.	Units (単位)	
Power Supply Voltages for LCD (LCD電源電圧)	VCC	for 3.3V system (3.3V系駆動時)	3.0	3.3	3.6	V	
Power Supply Currents for LCD (LCD電源電流)	ICC	for 3.3V system (3.3V系駆動時)	--	310	465	mA	
CMOS/TTL Input Voltage (CMOS/TTL入力電圧)	High	VCC=MAX	VIH	2.0	--	VCC	V
	Low	VCC=MIN	VIL	0	--	0.8	V
CMOS/TTL Output Voltage (CMOS/TTL出力電圧)	High	VCC=MAX	VIH	2.4	--	--	V
	Low	VCC=MIN	VIL	--	--	0.4	V

### 7.3.Interface Timing

#### 7.3.1.LVDS transmitter input signal

Parameter (項目)		Symbol (記号)	Min.	Typ.	Max.	Units (単位)
DCLK	Frequency (周波数)	$f_{CLK}$	20	25	30	MHz
	Period (周期)	$t_{CLK}$	33.3	40	50	ns
	Low Width (パルス幅(Low))	$t_{WCL}$	10	--	--	ns
	High Width (パルス幅(High))	$t_{WCH}$	10	--	--	ns
DATA (R,G,B,DENA, HD, VD)	Set up time (セットアップ時間)	$t_{DS}$	5	--	--	ns
	Hold time (保持時間)	$t_{DH}$	5	--	--	ns
DENA	Horizontal Active Time (水平表示時間)	$t_{HA}$	640	640	640	$t_{CLK}$
	Horizontal Front Porch (水平フロントポーチ)	$t_{HFP}$	0	--	--	$t_{CLK}$
	Horizontal Back Porch (水平バックポーチ)	$t_{HBP}$	7	--	--	$t_{CLK}$
	Vertical Active Time (垂直表示時間)	$t_{VA}$	480	480	480	$t_H$
	Vertical Front Porch (垂直フロントポーチ)	$t_{VFP}$	1	20	--	$t_H$
	Vertical Back Porch (垂直バックポーチ)	$t_{VBP}$	8	20	--	$t_H$
HD	Frequency (周波数)	$f_H$	27	31.5	38	kHz
	Period (周期)	$t_H$	26.3	31.7	37.0	$\mu s$
	Low Width (パルス幅(Low))	$t_{WHL}$	5	--	--	$t_{CLK}$
VD	Frequency (周波数)	$f_V$	55	60	70	Hz
	Period (周期)	$t_V$	14.3	16.7	18.2	ms
	Low Width (パルス幅(Low))	$t_{WVL}$	3	--	--	$t_H$

[Note](注)

- 1) DATA is latched at fall edge of DCLK in this timing specification.  
(DATAはDCLKの立ち下がりエッジで取り込みます。)
- 2) Polarities of HD and VD are negative in this specification.  
(HDとVDは負極性です。)
- 3) DENA (Data Enable) should always be positive polarity as shown in the timing specification.  
(DENA(データイネーブル)は常に正極性です。)
- 4) DCLK should appear during all invalid period, and HD should appear during invalid period of frame cycle.  
(DCLKは全ブランク期間にも入力が必要です。また、HDは垂直ブランク期間にも入力が必要です。)
- 5) Accepted only 640 data and 480 lines.  
(640ドット、480ライン分のデータのみ対応です。)
- 6) REV should be stable during operation.  
(REVは動作中に変更しないで下さい。)
- 7) LVDS timing follows the timing specifications of LVDS receiver IC:THC63LVDF84B(Thine).  
(LVDSのタイミングについては、LVDSのレシーバーIC:THC63LVDF84B(Thine)の仕様書に従って下さい。)

7.4. Timing Chart (タイミングチャート)

a. Pixel Timing Chart (ピクセルタイミングチャート)

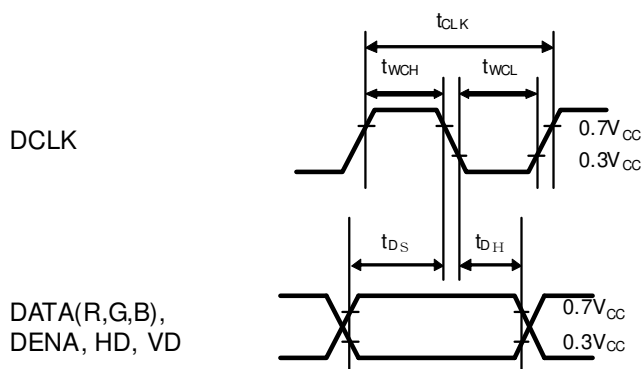

b. Horizontal Timing Chart (水平タイミングチャート)

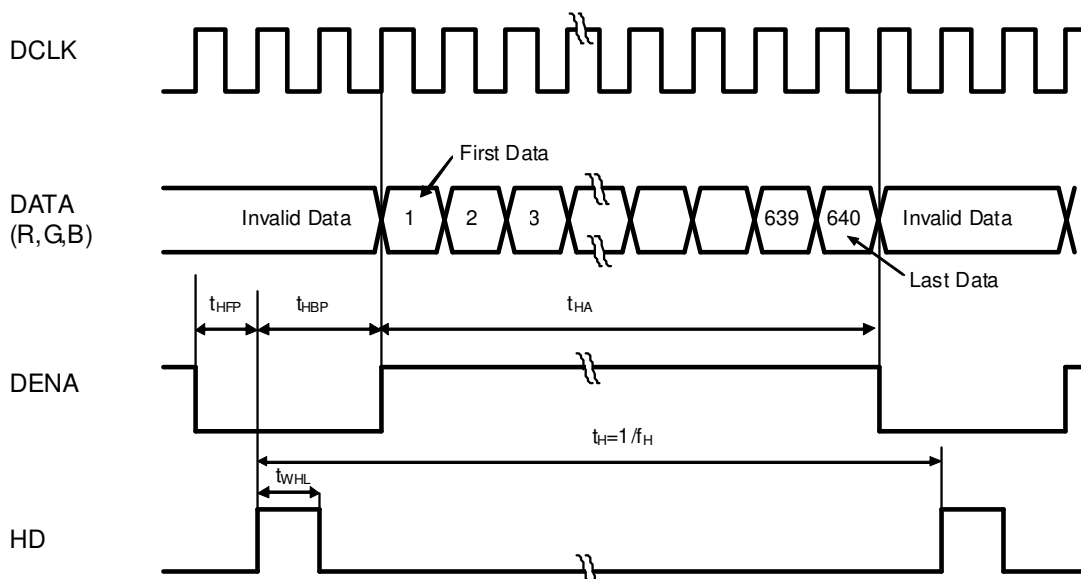

c. Vertical Timing Chart (垂直タイミングチャート)

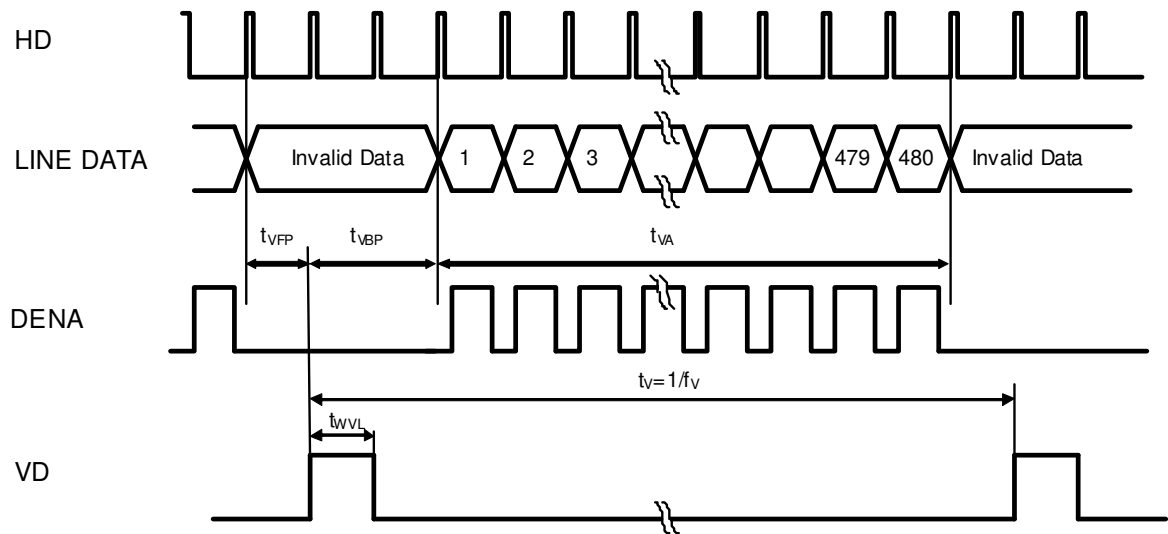

7.5.Pixel Alignment (画素配列)

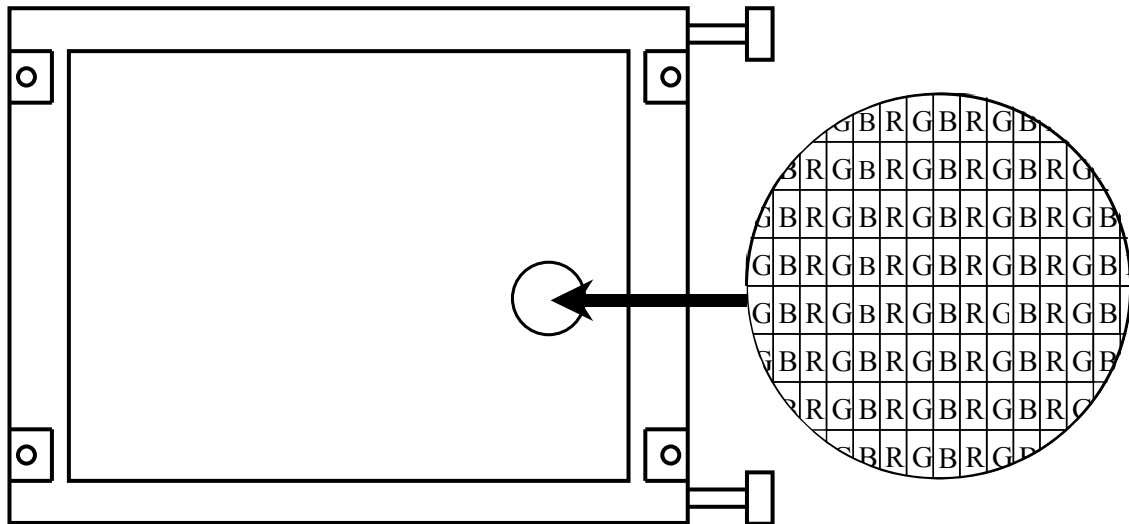

7.6.Color Data Assignment (カラーデータ設定表)

COLOR	INPUT DATA	R DATA						G DATA						B DATA					
		MSB			LSB			MSB			LSB			MSB			LSB		
		R5	R4	R3	R2	R1	R0	G5	G4	G3	G2	G1	G0	B5	B4	B3	B2	B1	B0
BASIC COLOR	BLACK	0	0	0	0	0	0	0	0	0	0	0	0	0	0	0	0	0	0
	RED (63)	1	1	1	1	1	1	0	0	0	0	0	0	0	0	0	0	0	0
	GREEN (63)	0	0	0	0	0	0	1	1	1	1	1	1	0	0	0	0	0	0
	BLUE (63)	0	0	0	0	0	0	0	0	0	0	0	0	1	1	1	1	1	1
	CYAN	0	0	0	0	0	0	1	1	1	1	1	1	1	1	1	1	1	1
	MAGENTA	1	1	1	1	1	1	0	0	0	0	0	0	1	1	1	1	1	1
	YELLOW	1	1	1	1	1	1	1	1	1	1	1	1	0	0	0	0	0	0
	WHITE	1	1	1	1	1	1	1	1	1	1	1	1	1	1	1	1	1	1
RED	RED (0)	0	0	0	0	0	0	0	0	0	0	0	0	0	0	0	0	0	0
	RED (1)	0	0	0	0	0	1	0	0	0	0	0	0	0	0	0	0	0	0
	RED (2)	0	0	0	0	1	0	0	0	0	0	0	0	0	0	0	0	0	0
	RED (62)	1	1	1	1	1	0	0	0	0	0	0	0	0	0	0	0	0	0
	RED (63)	1	1	1	1	1	1	0	0	0	0	0	0	0	0	0	0	0	0
GREEN	GREEN (0)	0	0	0	0	0	0	0	0	0	0	0	0	0	0	0	0	0	0
	GREEN (1)	0	0	0	0	0	0	0	0	0	0	0	1	0	0	0	0	0	0
	GREEN (2)	0	0	0	0	0	0	0	0	0	0	1	0	0	0	0	0	0	0
	GREEN (62)	0	0	0	0	0	0	1	1	1	1	1	0	0	0	0	0	0	0
	GREEN (63)	0	0	0	0	0	0	1	1	1	1	1	1	0	0	0	0	0	0
BLUE	BLUE (0)	0	0	0	0	0	0	0	0	0	0	0	0	0	0	0	0	0	0
	BLUE (1)	0	0	0	0	0	0	0	0	0	0	0	0	0	0	0	0	0	1
	BLUE (2)	0	0	0	0	0	0	0	0	0	0	0	0	0	0	0	0	1	0
	BLUE (62)	0	0	0	0	0	0	0	0	0	0	0	0	1	1	1	1	1	0
	BLUE (63)	0	0	0	0	0	0	0	0	0	0	0	0	1	1	1	1	1	1

[Note] (注)

1) Definition of gray scale (階調定義)

Color (n) --- n indicates gray scale level. (nは階調レベルを示します。)

Higher n means brighter level. (より高いnはより明るいレベルを意味します。)

2) Data 1:High, 0: Low

### 7.7. Inverted Scan Capability (スキャン反転機能)

This module has the capability of inverting scan direction by signaling from controller.

**Note:** Scan direction cannot be changed during operation.

(このモジュールには、コントローラから信号により走査方向を逆にすることができます。)

(注：スキャン方向の動作中の変更はできません。)

The following figure shows the relation between the display position and the scan direction.

(以下の図は、視認方向とスキャン方向の関係を表します。)

Normal scan(通常スキャン): REV = "L"

D( 1, 1)	D( 2, 1)	---	D( X, 1)	---	D(639, 1)	D(640, 1)
D( 1, 2)	D( 2, 2)	---	D( X, 2)	---	D(639, 2)	D(640, 2)
↓	↓	+	+	+	↓	↓
D( 1, Y)	D( 2, Y)	---	D( X, Y)	---	D(639, Y)	D(640, Y)
↓	↓	+	+	+	↓	↓
D( 1,479)	D( 2,479)	---	D( X,479)	---	D(639,479)	D(640,479)
D( 1,480)	D( 2,480)	---	D( X,480)	---	D(639,480)	D(640,480)

Reverse scan(反転スキャン): REV = "H"

D(640,480)	D(639,480)	---	D( X,480)	---	D( 2,480)	D( 1,480)
D(640,479)	D(639,479)	---	D( X,479)	---	D( 2,479)	D( 1,479)
↓	↓	+	+	+	↓	↓
D(640, Y)	D(639, Y)	---	D( X, Y)	---	D( 2, Y)	D( 1, Y)
↓	↓	+	+	+	↓	↓
D(640, 2)	D(639, 2)	---	D( X, 2)	---	D( 2, 2)	D( 1, 2)
D(640, 1)	D(639, 1)	---	D( X, 1)	---	D( 2, 1)	D( 1, 1)

The following drawing shows the relationship between the viewing direction and the scan direction.

(次の図は、見る方向と走査方向の関係を示します。)

Normal scan (通常スキャン)

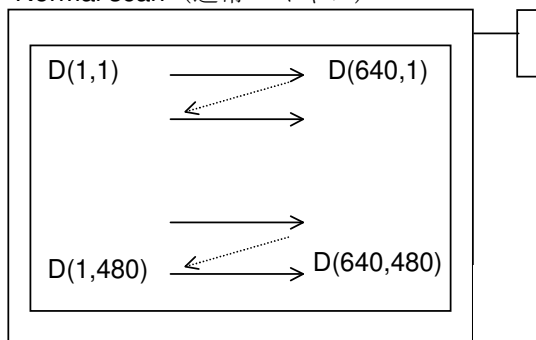

Reverse scan (反転スキャン)

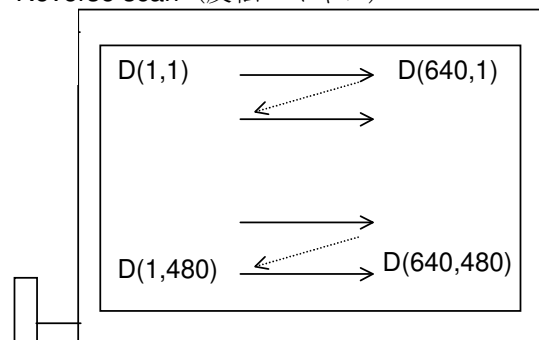

## 7.8. Lighting Specifications (照明仕様)

### 7.8.1. Absolute Maximum Ratings (絶対最大定格)

Ta=25°C

Parameter(項目)	Symbol(記号)	Conditions(条件)	Min.	Typ.	Max.	Units(単位)
Forward Current (順電流)	I <sub>F</sub>	Note 1	-	-	150	mA
Forward Voltage (順電圧)	V <sub>F</sub>	I <sub>F</sub> =80mA / line	-	16.0	18.0	V
Allowable Reverse Current (逆方向許容電流)	I <sub>R</sub>	-	-	-	85	mA
LED Power Dissipation (許容損失)	P <sub>D</sub>	-	-	-	540	mW
Backlight Life time (バックライト寿命)	—	Note 3,4,5	50,000	70,000	—	Hrs

Note 1 : This value is for each 1 line. (1列あたりの値を示します。)

Note 2 : Refer to the forward current derating curve. (ディレーティングカーブを下図に示す。)

Note 3 : Backlight life time is defined as time period that the actual luminance becomes 50% or lower of its initial value.

(バックライト寿命は輝度はその初期値より 50%以下になった時と定義します。)

Note 4 : Backlight life time depends on the ambient temperature.

(バックライト寿命は周囲の温度に依存します。)

The term "Backlight Life Time" is defined as room temperature, or 25°C.

(表記のバックライト寿命は周囲温度 25°Cで使用した場合です。)

Note 5 : Backlight life time will decrease under high temperature.

(バックライト寿命は高温下で減少します。)

【Forward Current Derating Curve (電流軽減特性)】

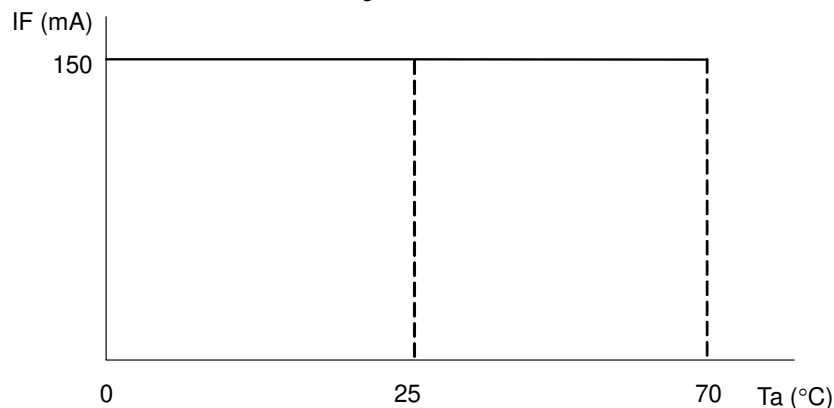

【LED Circuit (LED 回路)】

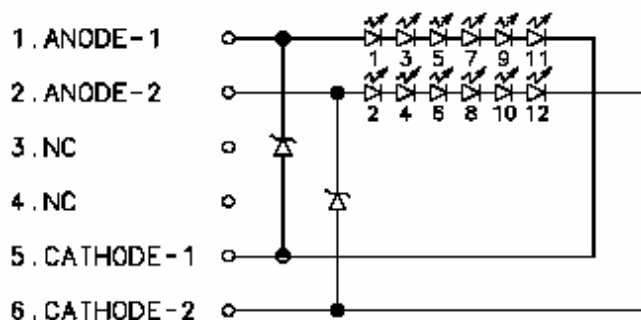



## 8. Optical Specifications (光学仕様)

### 8.1. Optical Characteristic (光学特性)

Item (項目)	Symbol (記号)	Conditions(条件)			Standard Value(規格値)			Unit (単位)	Method of Measure (測定法)	Remark (備考)
		$\theta$	$\phi$	C	Min.	Typ.	Max.			
(1) Brightness(輝度)	B	0°	0°	/	-	750		Cd/m <sup>2</sup>	(Fig.1)	Note1
(2) Contrast(コントラスト)	CR	Optimum Viewing Angle 最適視角での値			150	300	-	-		
(3) Color Coordinates (色度)	Red	Rx	0°	0°	/	0.52	0.55	0.58		-
		Ry	0°	0°	/	0.32	0.35	0.38		-
	Green	Gx	0°	0°	/	0.34	0.37	0.40		-
		Gy	0°	0°	/	0.53	0.56	0.59		-
	Blue	Bx	0°	0°	/	0.12	0.15	0.18		-
		By	0°	0°	/	0.11	0.14	0.17	-	
	White	Wx	0°	0°	/	0.28	0.32	0.36	-	
Wy		0°	0°	/	0.31	0.35	0.39	-		
(4) Brightness Uniformity (輝度ムラ)	-	0°	0°	/	0.7	-	-	-	(Fig.2)	
(5) Vertical Viewing Angle (垂直視野角)	Up	$\theta_U$	-	0°	$\geq 10$	-	30	-	Degree	(Fig.3)
	Down	$\theta_D$	-	0°	$\geq 10$	-	60	-	Degree	
(6) Horizontal Viewing Angle (水平視野角)	Left	$\phi_L$	0°	-	$\geq 10$	-	55	-	Degree	
	Right	$\phi_R$	0°	-	$\geq 10$	-	55	-	Degree	
(7) Response Time(応答時間)	Rise	$\tau_r$	0°	0°	/	-	15	-	ms	(Fig.4)
	Decay	$\tau_d$	0°	0°	/	-	16	-	ms	
(8) Haze(ヘイズ)	H	/			-	9	-	%		

Note1: Under the condition of IF=60mA/chip, Ta=25°C

- ◆ Conditions for Measuring
  - ◇ Environment: Dark room with no light or close to no light.
  - ◇ Temperature: 25±5°C
  - ◇ Humidity: 40~70%RH
- ◆ 測定条件は下記の通り
  - ◇ 測定環境：暗室またはそれに準じる環境
  - ◇ 測定温度：25±5°C
  - ◇ 測定湿度：40~70%RH
- ◆ Optimal viewing angle (The angle with best contrast)
- ◆ 主視角方向（コントラストが最大となる方向）

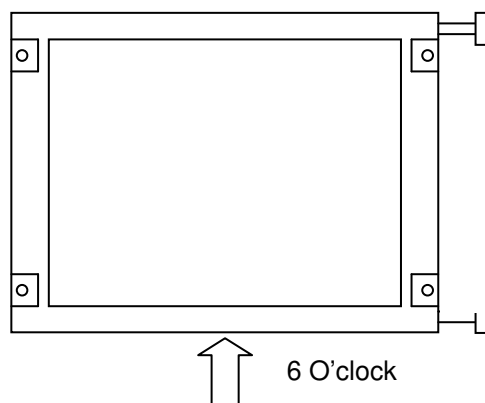

◆ Method of Brightness Measurement (輝度測定法) (Fig.1)

(1) Measuring Device (測定装置)

TOPCON BM-5, Measuring Field: 1°

(2) Measuring Point (測定点)

Center of Display  $\theta=0^\circ$ ,  $\phi=0^\circ$

On condition  $\theta$ : A vertical angle from measuring direction to perpendicular.

$\phi$ : A horizontal angle from measuring direction to perpendicular.

画面中央部  $\theta=0^\circ$ 、 $\phi=0^\circ$

ただし、 $\theta$ : 法線に対する視角面の垂直軸方向の角度

$\phi$ : 法線に対する視角面の水平軸方向の角度

(3) Method of Measuring (測定方法)

Apply signal voltage (displayed in white) to maximize brightness and measure brightness B ( $\text{cd}/\text{m}^2$ ).

The distance between BM-5's front lens to surface panel is 500mm.

Measured after backlight has been lit for more than 30 minutes.

輝度が最大となる信号電圧 (白表示) を印加し、輝度 B ( $\text{cd}/\text{m}^2$ ) を測定する。

測定距離は BM-5 レンズ前面よりパネル表面まで 500mm として測定する。

バックライト点灯 30 分以上経過後に測定する。

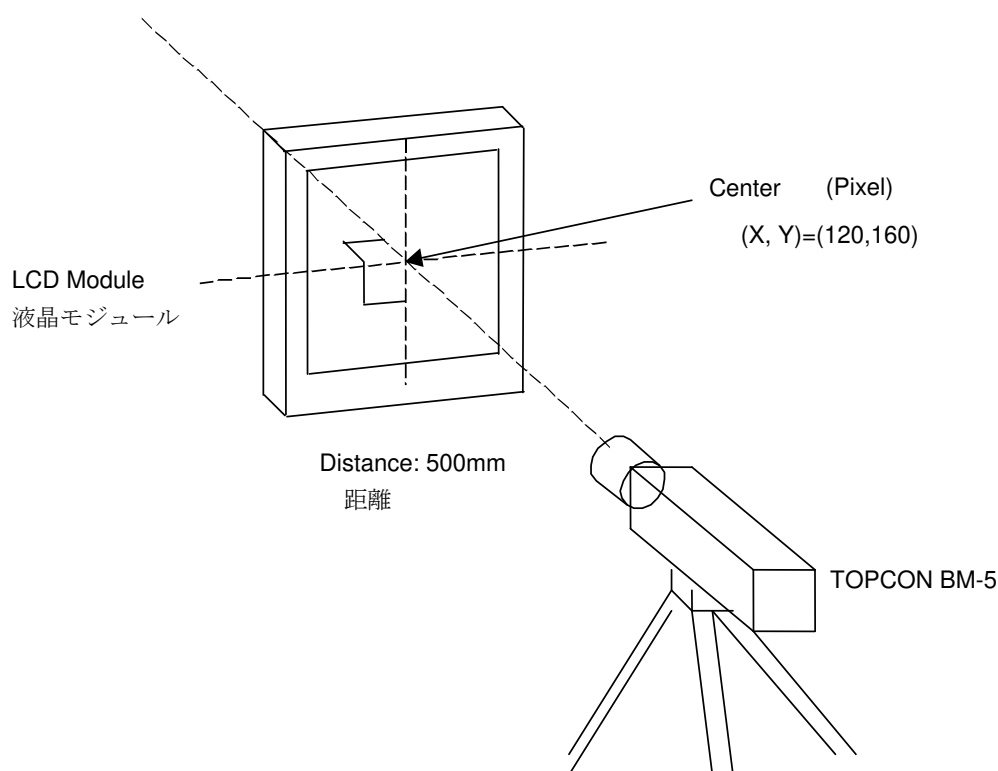

**Fig. 1**

◆ Method of Contrast Measurement (コントラスト測定法) (Fig.1)

- (1) Measuring Device (測定装置)  
TOPCON BM-5, Measuring Field: 1°
- (2) Measuring Point (測定点)  
Center of display: same as Method of Brightness Measurement  
画面中央部：輝度測定点と同様
- (3) Method of Measuring (測定方法)
  - Set LCD module to  $\theta=0^\circ$ ,  $\phi=0^\circ$ .  
(液晶表示モジュールを  $\theta=0^\circ$ 、 $\phi=0^\circ$  にセットする。)
  - Change signal voltage to measure maximum brightness Y1 and minimum brightness Y2.  
(信号電圧を変化させ、最大輝度 Y1、最小輝度 Y2 を測定する。)
  - Contrast is derived from  $CR=Y1/Y2$ .  
( $CR=Y1/Y2$  をコントラストとする。)

◆ Definition of Brightness Uniformity (輝度むらの定義) (Fig.2)

Definition is calculated from the 5 points (S0-S4) on the diagram below.

下図に示す点 (S0~S4) の測定点で、下記の計算式にて定義する。

$$\text{Standard value of Brightness Uniformity}[\%] = \frac{\text{S0~S4 MIN (最小値)}}{\text{S0~S4 MAX (最大値)}} \times 100$$

(輝度むらの規格値)

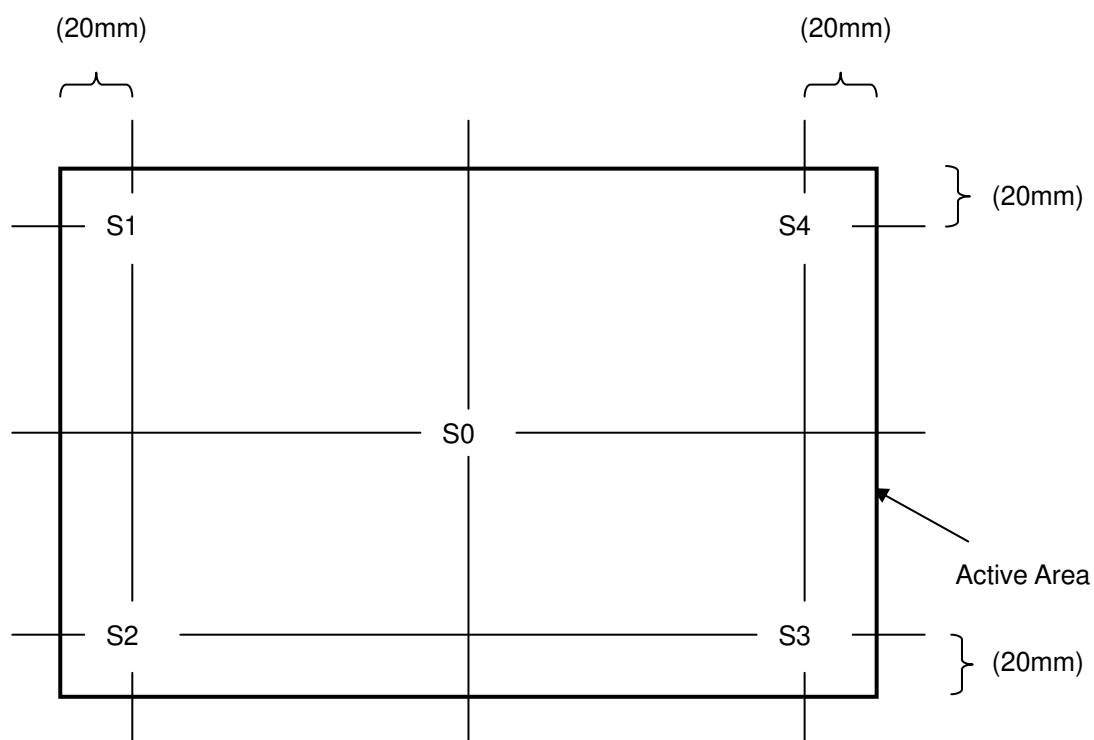

**Fig. 2**

◆ Method of Viewing Angle Measurement (視野角測定法) (Fig.3)

(1) Measuring Device (測定装置)

TOPCON BM-5, Measuring Field: 1°

(2) Measuring Point (測定点)

Center of display: Same as Method of Brightness Measurement

画面中央部：輝度測定点と同様

(3) Angle of Measuring (測定角度)

$\theta$  : An angle vertical to perpendicular line from the viewing direction.

$\theta$  : 法線に対する視角面の垂直軸方向の角度

$\phi$  : An angle horizontal to perpendicular from the viewing direction.

$\phi$  : 法線に対する視角面の水平軸方向の角度

(4) Method of Measuring (測定方法)

Set rotation table to  $\phi=0^\circ$  and set BM-5 to contrast 10 to measure angle  $\pm\theta$  for left and right direction of horizontal viewing angle  $\phi$ . Also set rotation table to  $\phi=90^\circ$  and set BM-5 to contrast 10 to measure angle  $\pm\theta$  for up and down direction of vertical viewing angle  $\theta$ .

回転ステージの  $\phi=0^\circ$  に固定して BM-7 がコントラスト 10 となる  $\pm\theta$  角度を読み取り左右方向の水平視野角  $\phi$ 、回転ステージの  $\phi=90^\circ$  に固定して BM-7 がコントラスト 10 となる  $\pm\theta$  角度を読み取り上下方向の垂直視野角  $\theta$  として記録する。

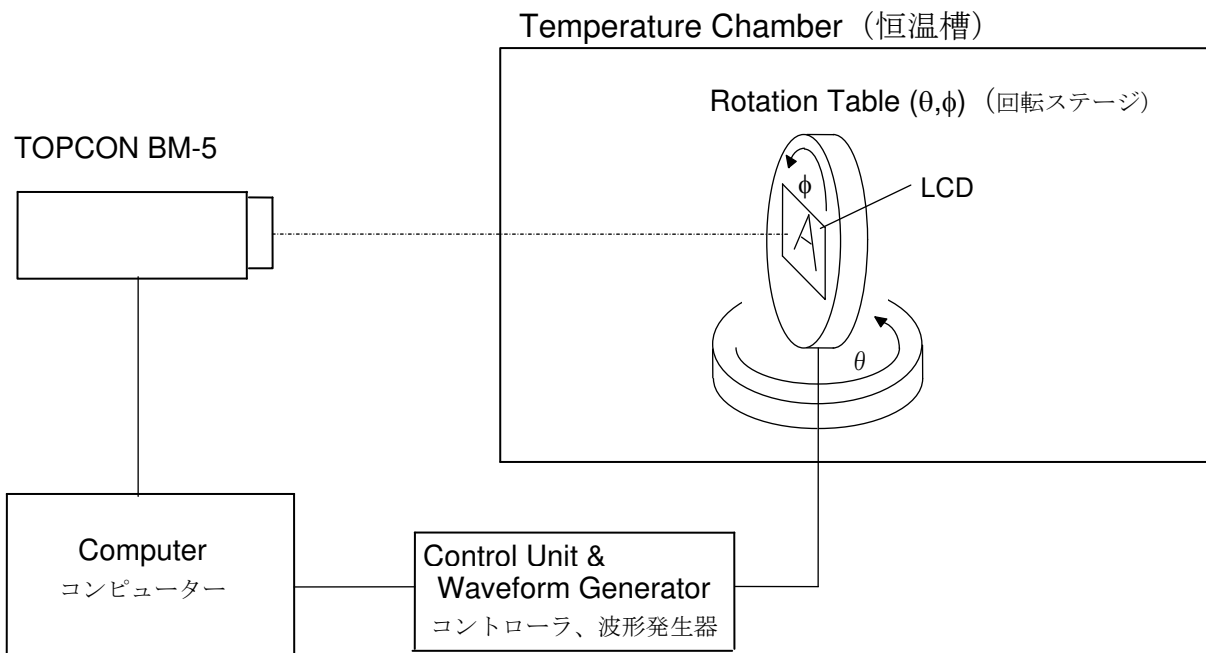

**Fig. 3**

◆ Measuring Response Time (応答時間の測定) (Fig.4)

(1) Measuring Device (測定装置)

TOPCON BM-5, Measuring Field: 1°

Tektronix Digital Oscilloscope

テクトロニクス社製 デジタルオシロスコープ

(2) Measuring Point (測定点)

Center of display, same as Method of Brightness Measurement

画面中央部：輝度測定点と同様

(3) Method of Measuring (測定方法)

- Set LCD panel to  $\theta=0^\circ$ , and  $\phi=0^\circ$ .

液晶表示パネルを  $\theta=0^\circ$ 、 $\phi=0^\circ$  にセットする。

- Input white→black→white to display by switching signal voltage.

白→黒→白と表示するように表示信号電圧を切り替えて印加する。

- If the luminance is 0% and 100% immediately before the change of signal voltage, then  $\tau_r$  is optical response time during the change from 90% to 10% immediately after rise of signal voltage, and  $\tau_d$  is optical response time during the change from 10% to 90% immediately after decay of signal voltage.

信号電圧切り替え直前の輝度をそれぞれ 0%、100%とすると、表示信号立ち上り後、光学応答が 90%から 10%に変化するのにかかる時間を  $\tau_r$  とし、表示信号立ち下がり後、光学応答が 10%から 90%にまで変化する時間を  $\tau_d$  とする。

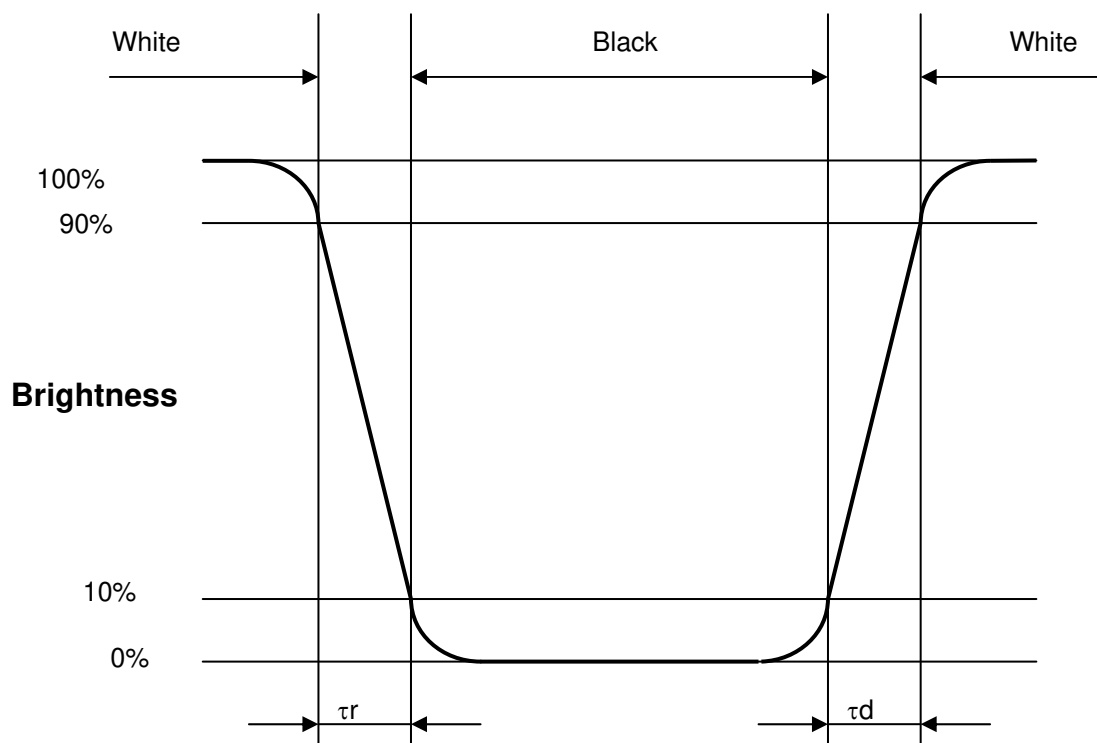

**Fig. 4**

## 9. Test (試験)

No abnormal function and appearance are found after the following tests.

下記の試験を実施した後、表示及び動作に異常がないこと。

Conditions: Unless otherwise specified, tests will be conducted under the following condition.

Temperature: 20±5°C

Humidity : 65±5%RH

tests will be not conducted under functioning state.

条件：特に指定の無い限り、温度 20±5°C、湿度 65±5%、無通電状態で行う。

No.	Parameter(項目)	Conditions (試験内容)	Notes(注記)
1	High Temperature Operating (高温動作試験)	70°C±2°C, 96hrs (operation state) (通電)	
2	Low Temperature Operating (低温動作試験)	-20°C±2°C, 96hrs (operation state) (通電)	1
3	High Temperature Storage (高温保存試験)	70°C±2°C, 96hrs	2
4	Low Temperature Storage (低温保存試験)	-20°C±2°C, 96hrs	1,2
5	Damp Proof Test (耐湿試験)	40°C±2°C, 90~95%RH, 96hrs	1,2
6	Vibration Test (振動試験)	Frequency:10-57Hz/Vibration width(one side):0.75mm :58-500Hz/Gravity:9.8m/s <sup>2</sup> Sweep time:11 minutes Test period:3hrs for each direction of X,Y,Z 振動周波数 : 10~57Hz, 片振幅 : 0.075mm : 58-500Hz, 加速度 : 9.8m/s <sup>2</sup> 掃引時間 : 11 分間 試験時間 3 時間, X,Y,Z 各方向 1 時間	3
7	Shock (衝撃)	Shock level:490m/s <sup>2</sup> Waveform:half sinusoidal wave, 11ms Number of shocks : One shock input in each direction of three mutually perpendicular axis for a total of six shock inputs 最高加速度 : 490m/s <sup>2</sup> 正弦半波, t=11ms 回数 : 1 回 / 1 方向, ±X, ±Y, ±Z 各方向	

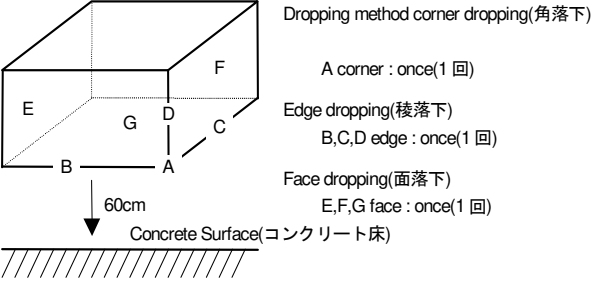
No.	Parameter(項目)	Conditions (試験内容)	Notes(注記)
9	Shock Test	<p>To be measured after dropping from 60cm high on the concrete surface in packing state.  (正規の梱包状態にて 60cm の高さから下記の要領でコンクリート床へ落下)</p> 	

Note 1: No dew condensation to be observed.

Note 2: The function test shall be conducted after 4 hours storage at the normal Temperature and humidity after removed from the test chamber.

Note 3: Vibration test will be conducted to the product itself without putting it in a container.

注 1 : 結露しないこと。

注 2 : 試験後、常温常湿に 4 時間放置した後、測定する。

注 3 : 容器を用いずモジュール単品で行う。

## 10. Appearance Standards (外觀規格)

### 10.1. Inspection conditions (外觀検査条件)

The distance between the eyes and the sample shall be more than 30cm.  
All directions for inspecting the sample should be within 45° against perpendicular line.  
サンプルとの距離 30cm 以上で目視により検査を行う。  
サンプルを目視する方向は、垂線に対して前後左右 45° の範囲内とする。

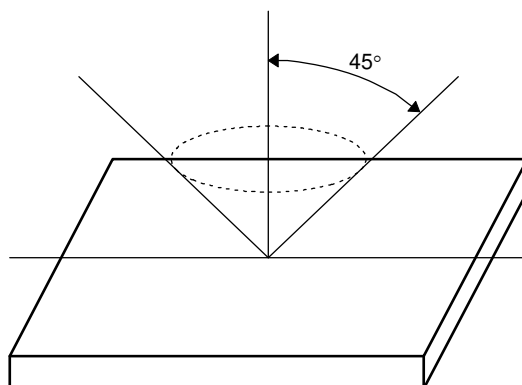

### 10.2. Definition of applicable Zones (サンプルの適用ゾーンの定義)

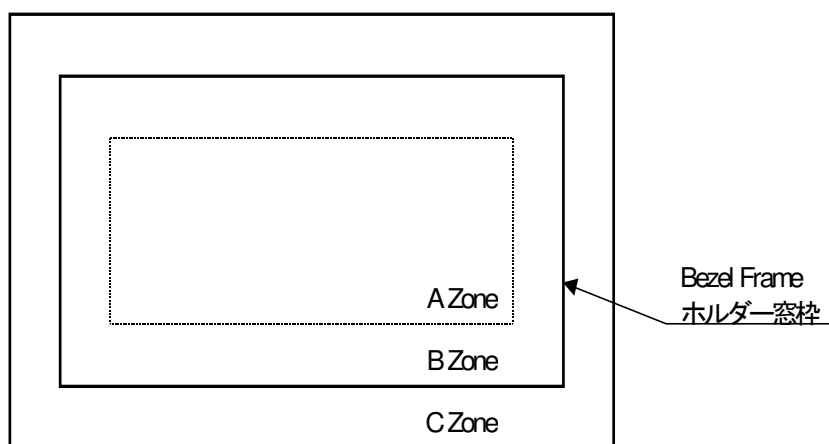

A Zone : Active display area

B Zone : Area from outside of "A Zone" to validity viewing area

C Zone : Rest parts

A Zone + B Zone = Validity viewing area

Aゾーン：ドット部

Bゾーン：ドットとホルダー窓枠に挟まれた部分

Cゾーン：その他の部分

Aゾーン+Bゾーン=有効視野範囲



10.3.Standards (規格)

No.	Parameter (項目)	Criteria (判定基準)																									
1	Polarizer Scratches (直線状のキズ)	<table border="1"> <thead> <tr> <th colspan="2">Zone(領域)</th> <th colspan="3">Acceptable Number(許容個数)</th> </tr> <tr> <th>X(mm)</th> <th>Y(mm)</th> <th>A</th> <th>B</th> <th>C</th> </tr> </thead> <tbody> <tr> <td>L ≤ 15</td> <td>0.01 &lt; W ≤ 0.05</td> <td colspan="2">4</td> <td>*</td> </tr> <tr> <td>L &gt; 15</td> <td>W &gt; 0.01</td> <td colspan="2">0</td> <td>*</td> </tr> <tr> <td>-</td> <td>W &gt; 0.05</td> <td colspan="2">0</td> <td>*</td> </tr> </tbody> </table> <p>X : Length(長さ), Y : Width(幅) * : Disregard(無視)</p>	Zone(領域)		Acceptable Number(許容個数)			X(mm)	Y(mm)	A	B	C	L ≤ 15	0.01 < W ≤ 0.05	4		*	L > 15	W > 0.01	0		*	-	W > 0.05	0		*
Zone(領域)		Acceptable Number(許容個数)																									
X(mm)	Y(mm)	A	B	C																							
L ≤ 15	0.01 < W ≤ 0.05	4		*																							
L > 15	W > 0.01	0		*																							
-	W > 0.05	0		*																							
2	DENT (円形状のキズ)	<table border="1"> <thead> <tr> <th>Zone(領域)</th> <th colspan="3">Acceptable Number(許容個数)</th> </tr> <tr> <th>Dimension (大きさ) (mm)</th> <th>A</th> <th>B</th> <th>C</th> </tr> </thead> <tbody> <tr> <td>0.30 &lt; D ≤ 0.50</td> <td colspan="2">4</td> <td>*</td> </tr> <tr> <td>0.50 &lt; D</td> <td colspan="2">0</td> <td>*</td> </tr> </tbody> </table> <p>Average Diameter(D) = (long+short)/2 * : Disregard(無視) 平均直径(D) = (長径 + 短径) / 2</p>	Zone(領域)	Acceptable Number(許容個数)			Dimension (大きさ) (mm)	A	B	C	0.30 < D ≤ 0.50	4		*	0.50 < D	0		*									
Zone(領域)	Acceptable Number(許容個数)																										
Dimension (大きさ) (mm)	A	B	C																								
0.30 < D ≤ 0.50	4		*																								
0.50 < D	0		*																								
3	BLACK and WHITE SPOT BUBBLE (円形状の黒い異物 気泡)	<table border="1"> <thead> <tr> <th>Zone(領域)</th> <th colspan="3">Acceptable Number(許容個数)</th> </tr> <tr> <th>Dimension (大きさ) (mm)</th> <th>A</th> <th>B</th> <th>C</th> </tr> </thead> <tbody> <tr> <td>0.30 &lt; D ≤ 0.50</td> <td colspan="2">5</td> <td>*</td> </tr> <tr> <td>0.50 &lt; D</td> <td colspan="2">0</td> <td>*</td> </tr> </tbody> </table>	Zone(領域)	Acceptable Number(許容個数)			Dimension (大きさ) (mm)	A	B	C	0.30 < D ≤ 0.50	5		*	0.50 < D	0		*									
Zone(領域)	Acceptable Number(許容個数)																										
Dimension (大きさ) (mm)	A	B	C																								
0.30 < D ≤ 0.50	5		*																								
0.50 < D	0		*																								
4	LINT (繊維状の異物)	<table border="1"> <thead> <tr> <th colspan="2">Zone(領域)</th> <th colspan="3">Acceptable Number(許容個数)</th> </tr> <tr> <th>X(mm)</th> <th>Y(mm)</th> <th>A</th> <th>B</th> <th>C</th> </tr> </thead> <tbody> <tr> <td>L ≤ 3.0</td> <td>W ≤ 0.15</td> <td colspan="2">4</td> <td>*</td> </tr> <tr> <td>L &gt; 3.0</td> <td>W ≤ 0.15</td> <td colspan="2">0</td> <td>*</td> </tr> <tr> <td>-</td> <td>W &gt; 0.15</td> <td colspan="2">According to BLACK SPOT (黒い異物のものによる)</td> <td>*</td> </tr> </tbody> </table> <p>X : Length(長さ), Y : Width(幅) * : Disregard(無視)</p>	Zone(領域)		Acceptable Number(許容個数)			X(mm)	Y(mm)	A	B	C	L ≤ 3.0	W ≤ 0.15	4		*	L > 3.0	W ≤ 0.15	0		*	-	W > 0.15	According to BLACK SPOT (黒い異物のものによる)		*
Zone(領域)		Acceptable Number(許容個数)																									
X(mm)	Y(mm)	A	B	C																							
L ≤ 3.0	W ≤ 0.15	4		*																							
L > 3.0	W ≤ 0.15	0		*																							
-	W > 0.15	According to BLACK SPOT (黒い異物のものによる)		*																							

No.	Parameter (項目)	Criteria (判定基準)																			
5	(a) Bright Dot (輝点) (b) Dark Dot (暗点)	<table border="1"> <thead> <tr> <th rowspan="2">Zone(領域) Dimension (大きさ) (mm)</th> <th colspan="3">Acceptable Number(許容個数)</th> </tr> <tr> <th>A</th> <th>B</th> <th>C</th> </tr> </thead> <tbody> <tr> <td>Bright Dot (輝点)</td> <td colspan="2">7 (<math>G \leq 3</math>)</td> <td>*</td> </tr> <tr> <td>Dark Dot (暗点)</td> <td colspan="2">7</td> <td>*</td> </tr> <tr> <td>TOTAL (合計)</td> <td colspan="3">10</td> </tr> </tbody> </table>	Zone(領域) Dimension (大きさ) (mm)	Acceptable Number(許容個数)			A	B	C	Bright Dot (輝点)	7 ( $G \leq 3$ )		*	Dark Dot (暗点)	7		*	TOTAL (合計)	10		
Zone(領域) Dimension (大きさ) (mm)	Acceptable Number(許容個数)																				
	A	B	C																		
Bright Dot (輝点)	7 ( $G \leq 3$ )		*																		
Dark Dot (暗点)	7		*																		
TOTAL (合計)	10																				
6	TWO Adjacent Dot (2 連続点欠陥数)	<table border="1"> <thead> <tr> <th rowspan="2">Zone(領域) Dimension (大きさ) (mm)</th> <th colspan="3">Acceptable Number(許容個数)</th> </tr> <tr> <th>A</th> <th>B</th> <th>C</th> </tr> </thead> <tbody> <tr> <td>Bright Dot (輝点)</td> <td colspan="2">3 PAIRS</td> <td>*</td> </tr> <tr> <td>Dark Dot (暗点)</td> <td colspan="2">3 PAIRS</td> <td>*</td> </tr> </tbody> </table>	Zone(領域) Dimension (大きさ) (mm)	Acceptable Number(許容個数)			A	B	C	Bright Dot (輝点)	3 PAIRS		*	Dark Dot (暗点)	3 PAIRS		*				
Zone(領域) Dimension (大きさ) (mm)	Acceptable Number(許容個数)																				
	A	B	C																		
Bright Dot (輝点)	3 PAIRS		*																		
Dark Dot (暗点)	3 PAIRS		*																		
7	Three or More Adjacent Dot ( 3 連続点欠陥)	NOT ALLOWED (なきこと。)																			
8	Distance between the dot defects (点欠陥距離)	<table border="1"> <thead> <tr> <th rowspan="2">Zone(領域) Dimension (大きさ) (mm)</th> <th colspan="3">Acceptable Number(許容個数)</th> </tr> <tr> <th>A</th> <th>B</th> <th>C</th> </tr> </thead> <tbody> <tr> <td>Bright Dot (輝点)</td> <td colspan="2">5 mm</td> <td>*</td> </tr> <tr> <td>Dark Dot (暗点)</td> <td colspan="2">5 mm</td> <td>*</td> </tr> </tbody> </table>	Zone(領域) Dimension (大きさ) (mm)	Acceptable Number(許容個数)			A	B	C	Bright Dot (輝点)	5 mm		*	Dark Dot (暗点)	5 mm		*				
Zone(領域) Dimension (大きさ) (mm)	Acceptable Number(許容個数)																				
	A	B	C																		
Bright Dot (輝点)	5 mm		*																		
Dark Dot (暗点)	5 mm		*																		
9	Line Defect (線欠陥)	NOT ALLOWED (なきこと。)																			