



Chipsmall Limited consists of a professional team with an average of over 10 year of expertise in the distribution of electronic components. Based in Hongkong, we have already established firm and mutual-benefit business relationships with customers from,Europe,America and south Asia,supplying obsolete and hard-to-find components to meet their specific needs.

With the principle of “Quality Parts,Customers Priority,Honest Operation,and Considerate Service”,our business mainly focus on the distribution of electronic components. Line cards we deal with include Microchip,ALPS,ROHM,Xilinx,Pulse,ON,Everlight and Freescale. Main products comprise IC,Modules,Potentiometer,IC Socket,Relay,Connector.Our parts cover such applications as commercial,industrial, and automotives areas.

We are looking forward to setting up business relationship with you and hope to provide you with the best service and solution. Let us make a better world for our industry!



## Contact us

Tel: +86-755-8981 8866 Fax: +86-755-8427 6832

Email & Skype: info@chipsmall.com Web: www.chipsmall.com

Address: A1208, Overseas Decoration Building, #122 Zhenhua RD., Futian, Shenzhen, China



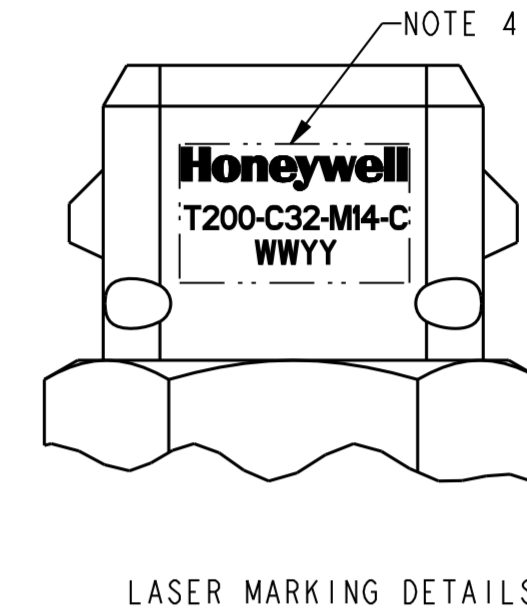
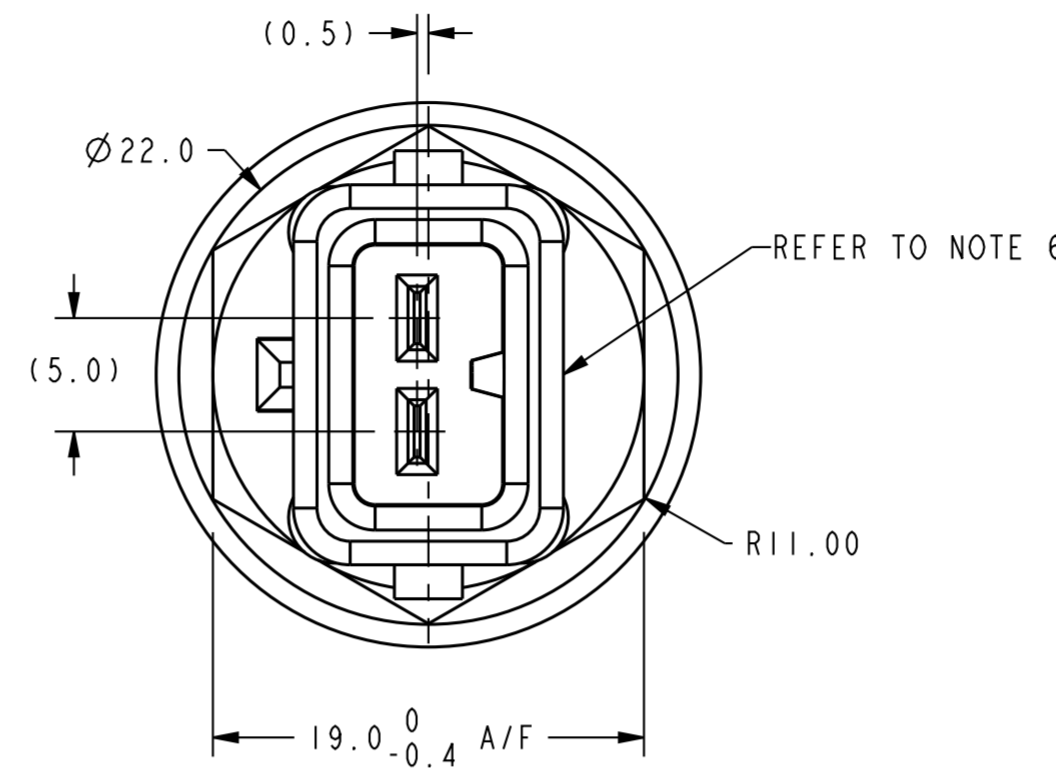
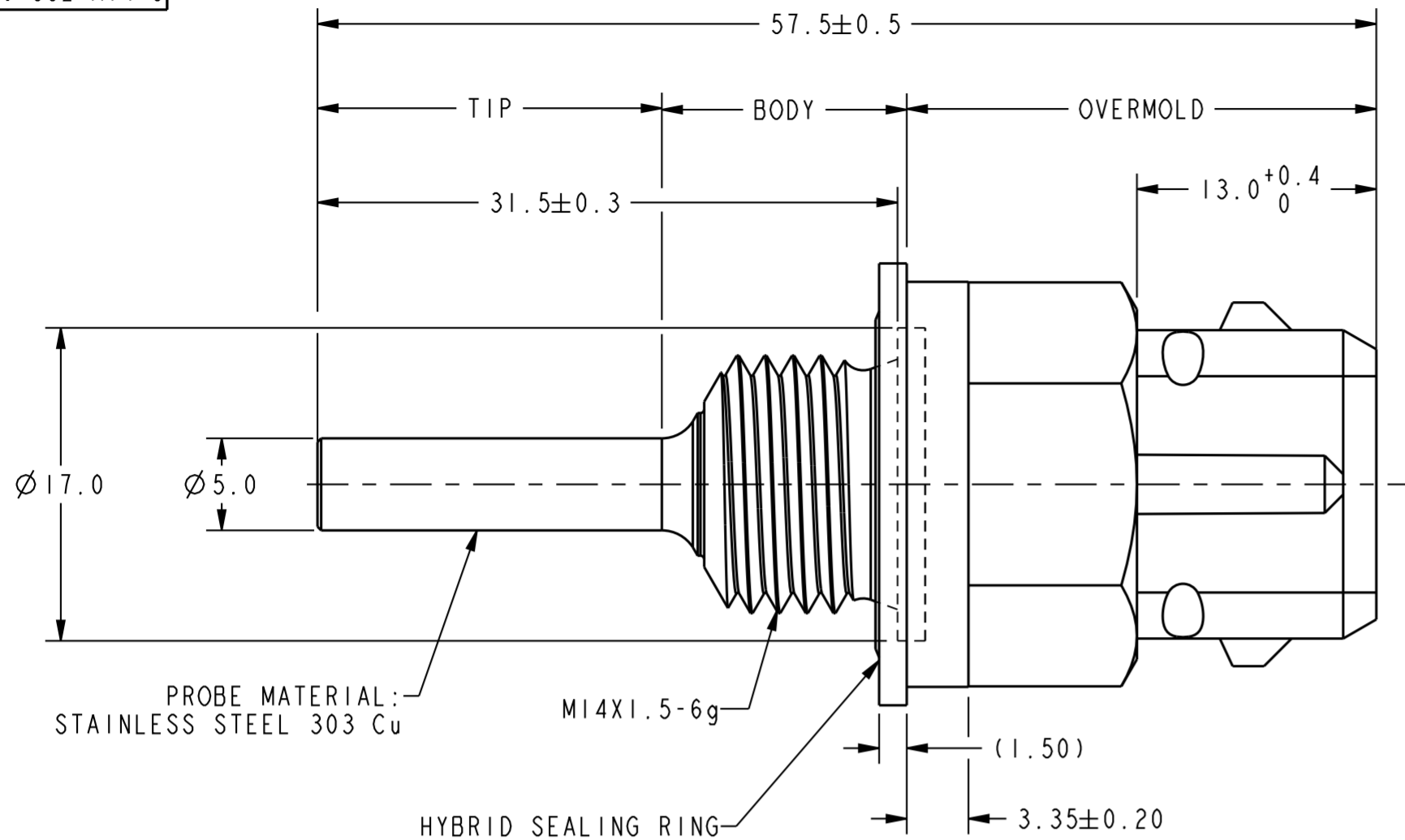

NOTES

- 1 - MASS OF PRODUCT - 23g.
- 2 - FINAL INSTALLATION TORQUE TO 15±3 N-m.
- 3 - CONNECTOR OVERMOLD PLASTIC MATERIAL : LCP - 30% GLASS FILLED.
- 4 - FOLLOWING INFORMATION IS LASER MARKED ON THE CONNECTOR FACE.  
HONEYWELL LOGO  
HONEYWELL PART NO.  
MANUFACTURING WEEK AND YEAR IN THE FORM WWYY  
EXAMPLE 1707 FOR PART MANUFACTURED ON APR 27 2007 Viz WK17 2007.
- 5 - SENSOR MUST BE USED WITH SEALING WASHER IN PLACE.
- 6 - RoHS COMPLIANT.

VOLTAGES

TYPICAL POWER SUPPLY :  $V_p = +5V \pm 0.1V$

THERMISTOR CHARACTERISTICS

RESISTANCE AT 25°C :  $R_{25} = 2K\Omega \pm 3.75\%$

BETA 25/85 :  $B_{25/85} = 3420K \pm 1\%$

TABLE I: PROBE R-T CHARACTERISTICS

Temperature (°C)	Resistance (Ohms)			Temp. Tol. (± °C)
	Minimum	Nominal	Maximum	
-40	36308	39650	42992	1.5
-20	12890	13844	14798	1.4
0	5179	5489	5799	1.3
20	2316	2419	2522	1.1
25	1925	2000	2075	1.0
50	805.8	833	860.2	1.0
80	326.7	336.1	345.5	1.0
100	190.7	197.3	203.8	1.3
150	60.93	63.77	66.61	2.2
180	34.45	36.26	38.08	2.8
200	24.49	25.87	27.25	3.3

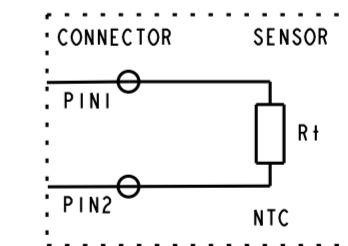

SCHEMATIC VIEW

INPUT DATA	MAX OPERATING TEMPERATURE OF PROBE	+200°C CONTINUOUS
	MIN OPERATING TEMPERATURE OF PROBE	-40 °C
	SUPPLY VOLTAGE RANGE	+5VDC±4% TYPICAL
	SUPPLY VOLTAGE PROTECTION	NONE
	SHORT CIRCUIT PROTECTION	NONE
OUTPUT DATA	TYPE	PASSIVE
	TRANSFER FUNCTION	DEPENDENT ON SYSTEM CIRCUIT, SEE TABLE I FOR TEMP. Vs RES. OUTPUT
	RESPONSE TO STEP INPUT CHANGE	TIME CONSTANT T63.2%, IN 10m/s GAS FLOW @ 150°C <15.0s
ENVIRONMENTAL DATA	OPERATING TEMPERATURE RANGE OF PROBE BODY	-40 °C TO +200 °C CONTINUOUS
	STORAGE TEMPERATURE RANGE	-40 °C TO +150 °C
	APPLICATION	ENGINE APPLICATION
INSTALLATION GUIDELINES	VIBRATION RANDOM	30g PEAK
	PROBE TO HOUSING SEAL	HYBRID SEALING RING
	CONNECTOR SEAL	IP59K
	HARNESS/HOUSING INTERFERENCE SEAL	GOLD PLATED CONTACT TERMINALS IN OVERMOLDED CONNECTOR
	WIRE SEALED	N/A
	MATING CONNECTOR	TYCO JPT CONNECTOR PART# 282762-1
MOUNTING	MI4X1.5- 6H PORT	

DESIGN UNITS: MM  
TOLERANCES UNLESS NOTED:

NO PLACES	x	±	0.400
ONE PLACE	.x	±	0.2
TWO PLACE	.xx	±	0.10
THREE PLACE	.xxx	±	0.005
FOUR PLACE	.xxxx	±	0.0050
ANGLES	x	±	1

THIRD ANGLE PROJECTION

DRAWN: RK 19JULY11  
CHECK: GK 19JULY11

THIS DRAWING COVERS A PROPRIETARY ITEM AND IS THE PROPERTY OF HONEYWELL. THIS DRAWING IS NOT TO BE COPIED OR USED WITHOUT THE PERMISSION OF HONEYWELL.

INTERPRET PER ASME Y14.5M-1994 OTHER HONEYWELL ENGINEERING STANDARDS MAY APPLY

**Honeywell**

TITLE: **TEMPERATURE SENSOR**

SIZE: A2 | TYPE: I | DRAWING NAME: 50059659 | REV: A

Pro/ENGINEER 3D SCALE: 3:1 | SHEET: 1 OF 1