



Chipsmall Limited consists of a professional team with an average of over 10 year of expertise in the distribution of electronic components. Based in Hongkong, we have already established firm and mutual-benefit business relationships with customers from,Europe,America and south Asia,supplying obsolete and hard-to-find components to meet their specific needs.

With the principle of “Quality Parts,Customers Priority,Honest Operation,and Considerate Service”,our business mainly focus on the distribution of electronic components. Line cards we deal with include Microchip,ALPS,ROHM,Xilinx,Pulse,ON,Everlight and Freescale. Main products comprise IC,Modules,Potentiometer,IC Socket,Relay,Connector.Our parts cover such applications as commercial,industrial, and automotives areas.

We are looking forward to setting up business relationship with you and hope to provide you with the best service and solution. Let us make a better world for our industry!



Contact us

Tel: +86-755-8981 8866 Fax: +86-755-8427 6832

Email & Skype: info@chipsmall.com Web: www.chipsmall.com

Address: A1208, Overseas Decoration Building, #122 Zhenhua RD., Futian, Shenzhen, China



Revision level		Revision Record	Changed	Date	Approved	Date
part	drawing					
-	01	See ECN 010928	A.A.C.	01/24/08	K.A.C.	01/24/08

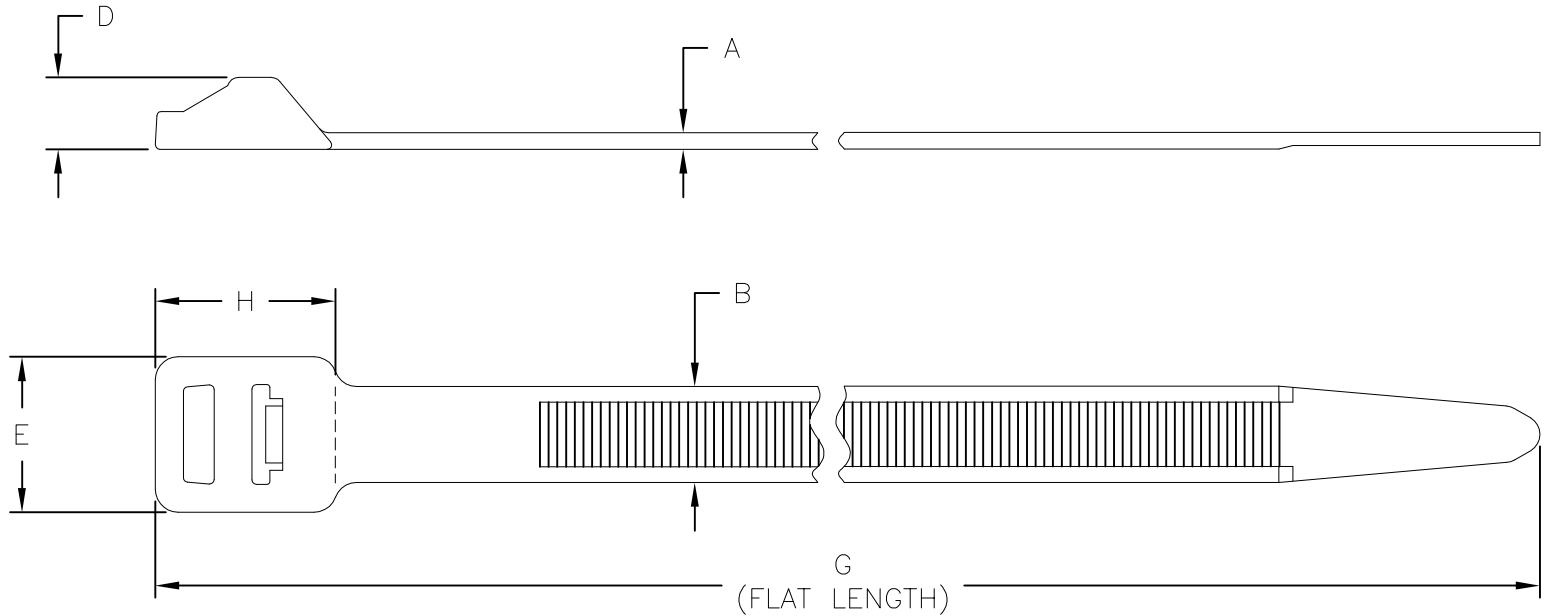

PRODUCT CODE DESCRIPTION

T250S_HS
 COLOR
 (CONSULT FACTORY FOR AVAILABLE COLORS)

Aerospace Spec Tie SAE AS33671	Product Code	Cable Range (mm)	Material	A	B	D	E	G	H	Min Loop Tensile Strength (newtons)
no	T250S_	12 to 50	PA66	1.9 ±0.2	12.5±0.2	9.5 ±0.5	20.0 ±0.5	230.0 ±5.0	22.4 ±1.0	1115
no	T250S_HS		PA66HS							

SEE CHART

Material

Dimension tolerances unless otherwise specified

- .XXXX =
- .XXX =
- .XX =
- .X = ± NOTED
- < =

Dimension Units mm

PERFORMANCE SPECIFICATION

ACAD MECH
2008

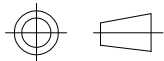

Drawn	G.G.G.	07/31/91
Approved	K.A.C.	01/24/08

Scale 1:1 Computer File Number CT\CST\2250001_01
 Title T250S HEAVY DUTY LASHING CABLE TIE Phase: Production

ALL PROPRIETARY RIGHTS IN THE SUBJECT MATTER SHOWN ON THIS DRAWING ARE EXCLUSIVE PROPERTY OF HELLERMANN TYTON

HellermannTyton

7930 N. Faulkner Rd.
 Milwaukee, WI 53224
 Ph: (414) 355-1130
 Fx: (414) 362-8338

Drawing-No

CT2250001CST

Format

AH

Sheet 1 of 1