



Chipsmall Limited consists of a professional team with an average of over 10 year of expertise in the distribution of electronic components. Based in Hongkong, we have already established firm and mutual-benefit business relationships with customers from,Europe,America and south Asia,supplying obsolete and hard-to-find components to meet their specific needs.

With the principle of “Quality Parts,Customers Priority,Honest Operation,and Considerate Service”,our business mainly focus on the distribution of electronic components. Line cards we deal with include Microchip,ALPS,ROHM,Xilinx,Pulse,ON,Everlight and Freescale. Main products comprise IC,Modules,Potentiometer,IC Socket,Relay,Connector.Our parts cover such applications as commercial,industrial, and automotives areas.

We are looking forward to setting up business relationship with you and hope to provide you with the best service and solution. Let us make a better world for our industry!



Contact us

Tel: +86-755-8981 8866 Fax: +86-755-8427 6832

Email & Skype: info@chipsmall.com Web: www.chipsmall.com

Address: A1208, Overseas Decoration Building, #122 Zhenhua RD., Futian, Shenzhen, China



DO NOT
SCALE FROM
THIS PRINT

T2M-1XX-XX-X-D-XX-XX

NO OF POSITIONS

**02, **04, -05, -07, -10, -15,
-20, -25, & -30 (PER ROW)
AVAILABLE AS STANDARD;
OTHER SIZES BETWEEN -05
THRU -50 AVAILABLE AS ASO

LEAD STYLE
-01

PLATING SPECIFICATION

-L: 10µ" SELECTIVE GOLD IN CONTACT
AREA, MATTE TIN ON TAIL
(USE T-1S13-XX-L-2)
-S: 30µ" SELECTIVE GOLD IN CONTACT
AREA, MATTE TIN ON TAIL
(USE T-1S13-XX-S-2)

ROW SPECIFICATION
-D: DOUBLE ROW

OPTION

-DS: DUAL SCREW DOWN (SEE FIG 6, SHT 3)
(FOR 1.57mm [.062] PCB)
(AVAILABLE 5-30 POSITIONS ONLY)
(NOT AVAILABLE WITH -RA, -WT OPTIONS)
(USE T-1S13-04-X-2 WITH TH OPTION
AND TI-M2-4-VSFM-T,
USE T-1S13-20-X-2 WITH SM OPTION
AND TI-M2-4-VSFM-T)
-K: POLYIMIDE FILM (-SM OPTION ONLY)
(USE K-DOT-.295-.406-.005, SEE FIG 4)
(NOT AVAILABLE IN -02 OR -04 POSITIONS)
-TR: TAPE & REEL (-SM OPTION ONLY)
(NOT AVAILABLE IN -02 OR -04 POSITIONS)
-WT: WELD TAB : (USE WT-25-07-T);
(-SM, SEE FIG 3, SHT 2)
(-TH, SEE FIG 5, SHT 2)
-RA: (USE WT-81-01-T)

OPTION

-TH: THROUGH HOLE (SEE FIG 1)
-RA: RIGHT ANGLE (SEE FIG 2)
-SM: SURFACE MOUNT (SEE FIG 3, SHT 2)

** = ONLY AVAILABLE WITH -SM-WT OR -RA-WT OPTIONS

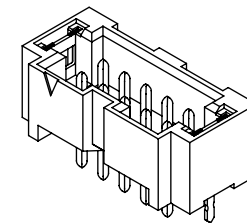
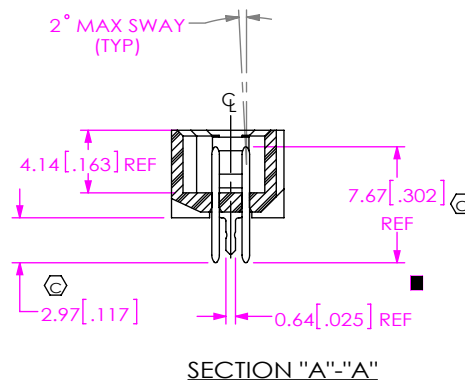
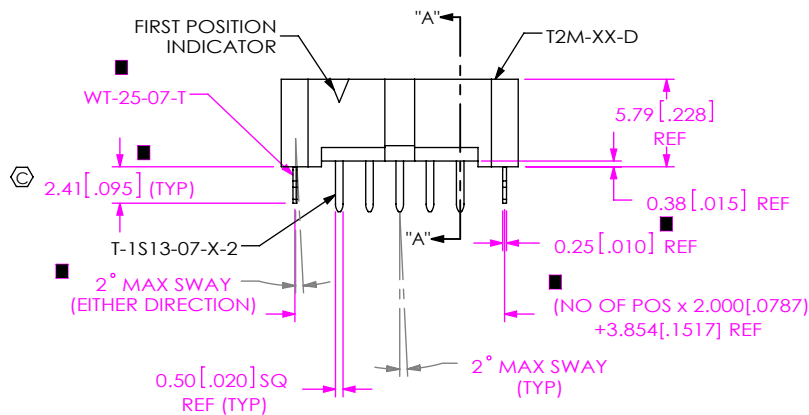
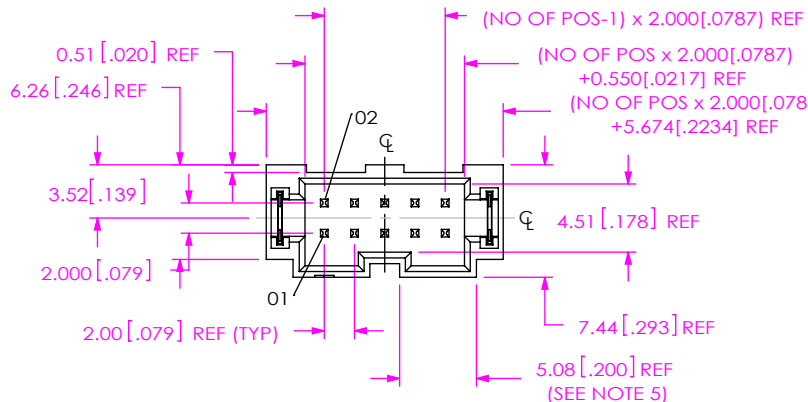

FIG 1
T2M-105-01-X-D-TH-XX
(■ = ONLY APPLICABLE WITH -WT OPTION)

NOTES:

- ⊕ REPRESENTS A CRITICAL DIMENSION.
- MINIMUM PUSHOUT FORCE: 4.44N[1.0 LB].
- POST HEIGHT VARIATION BETWEEN ANY TWO PINS: 0.13[.005] MAXIMUM.
- MAXIMUM PIN ROTATION IN BODY TO BE 2°.
- DUAL POLARIZATION SLOT NOT AVAILABLE ON CONNECTOR WITH LESS THAN 5 POSITIONS.
- MINIMUM RETENTION FORCE FOR WELD TABS: 4.44N[1.0 LB].

UNLESS OTHERWISE SPECIFIED,
DIMENSIONS ARE IN MILLIMETERS.
TOLERANCES ARE:
DECIMALS ANGLES
X.X: ±0.3 [.01] 2°
X.XX: ±0.13 [.005]
X.XXX: ±0.051 [.0020]

PROPRIETARY NOTE

THIS DOCUMENT CONTAINS CONFIDENTIAL AND PROPRIETARY INFORMATION AND ALL DESIGN, MANUFACTURING, REPRODUCTION, USE, PATENT RIGHTS AND SALES RIGHTS ARE EXPRESSLY RESERVED BY SAMTEC, INC. THIS DOCUMENT SHALL NOT BE DISCLOSED, IN WHOLE OR PART, TO ANY UNAUTHORIZED PERSON OR ENTITY NOR REPRODUCED, TRANSFERRED OR INCORPORATED IN ANY OTHER PROJECT IN ANY MANNER WITHOUT THE EXPRESS WRITTEN CONSENT OF SAMTEC, INC.

MATERIAL: DO NOT SCALE DRAWING SHEET SCALE: 2:1
INSULATOR: LCP, COLOR: BLACK
TERMINAL: PHOS BRONZE
WELD TAB: PHOS BRONZE
KAPTON: POLYIMIDE FILM



520 PARK EAST BLVD, NEW ALBANY, IN 47150
PHONE: 812-944-6733 FAX: 812-948-5047
e-Mail: info@SAMTEC.com code 55322

DESCRIPTION:
2mm SHROUDED TERMINAL STRIP
DWG. NO.
T2M-1XX-XX-X-D-XX-XX
BY: J. BORGELT 3/23/09 SHEET 1 OF 3

FIG 3

T2M-105-01-X-D-SM-WT SHOWN
(SAME AS FIG 1, EXCEPT AS SHOWN)

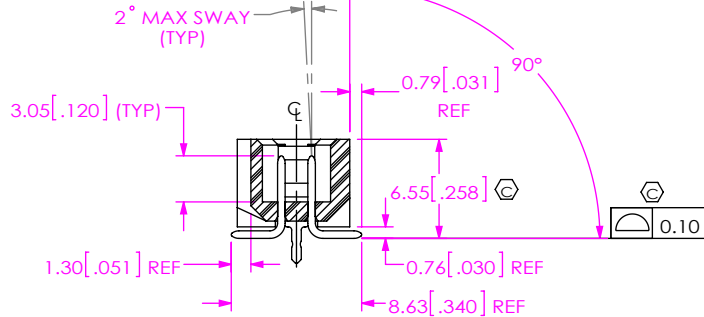
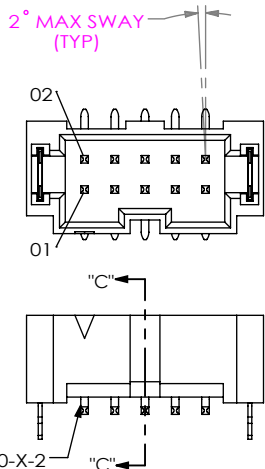

SECTION "C"-"C"

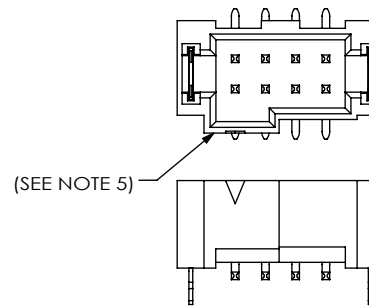
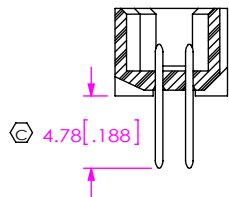
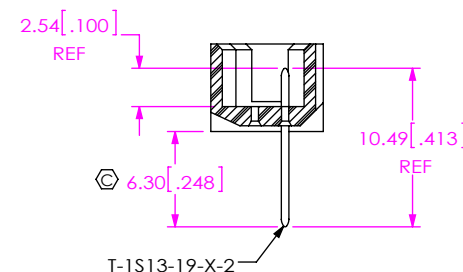

FIG 5

T2M-104-01-X-D-SM-WT
(SAME AS FIG 1, EXCEPT AS SHOWN)
(T2M-102-01-X-D-SM-WT SIMILAR)

-RA IN PROCESS 1



-SM IN PROCESS 1

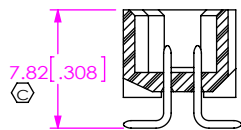

-SM IN PROCESS 2

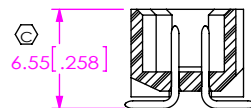

-SM IN PROCESS 3

FIG 2

T2M-105-01-X-D-RA-XX
(SAME AS FIG 1, EXCEPT AS SHOWN)

■ = ONLY APPLICABLE WITH -WT OPTION

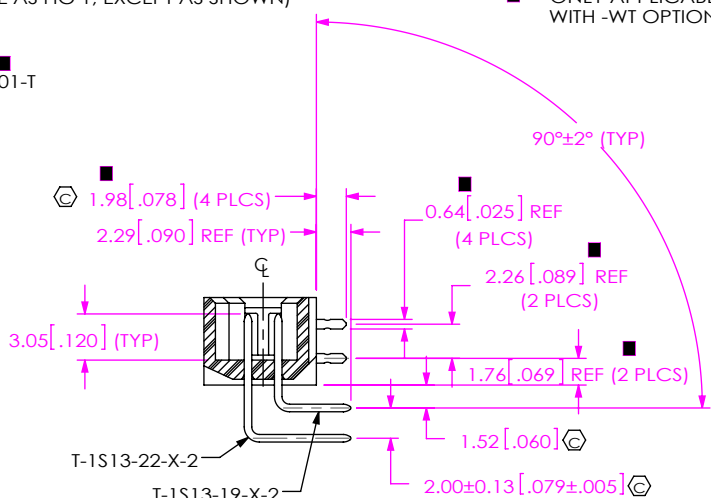
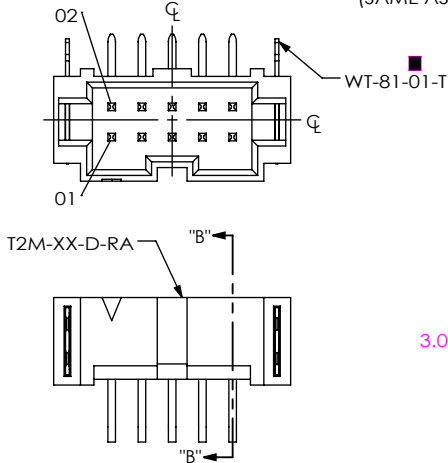

SECTION "B"-"B"

-RA IN PROCESS 2

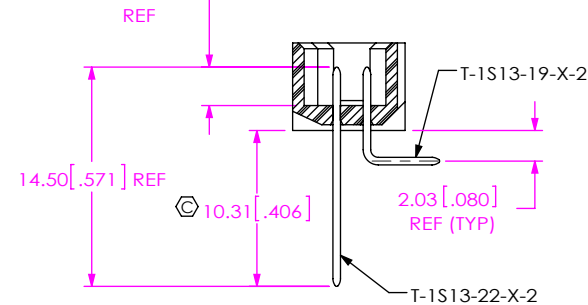

PROPRIETARY NOTE
THIS DOCUMENT CONTAINS CONFIDENTIAL AND PROPRIETARY INFORMATION AND ALL DESIGN, MANUFACTURING, REPRODUCTION, USE, PATENT RIGHTS AND SALES RIGHTS ARE EXPRESSLY RESERVED BY SAMTEC, INC. THIS DOCUMENT SHALL NOT BE DISCLOSED, IN WHOLE OR PART, TO ANY UNAUTHORIZED PERSON OR ENTITY NOR REPRODUCED, TRANSFERRED OR INCORPORATED IN ANY OTHER PRODUCT IN ANY MANNER WITHOUT THE EXPRESS WRITTEN CONSENT OF SAMTEC, INC.

DO NOT SCALE DRAWING

SHEET SCALE: 2:1

samtec

520 PARK EAST BLVD, NEW ALBANY, IN 47150
PHONE: 812-944-6733 FAX: 812-948-5047
e-Mail: info@SAMTEC.com code 55322

DESCRIPTION: 2mm SHROUDED TERMINAL STRIP

DWG. NO. T2M-1XX-XX-X-D-XX-XX

BY: J. BORGELT 3/23/09 SHEET 2 OF 3

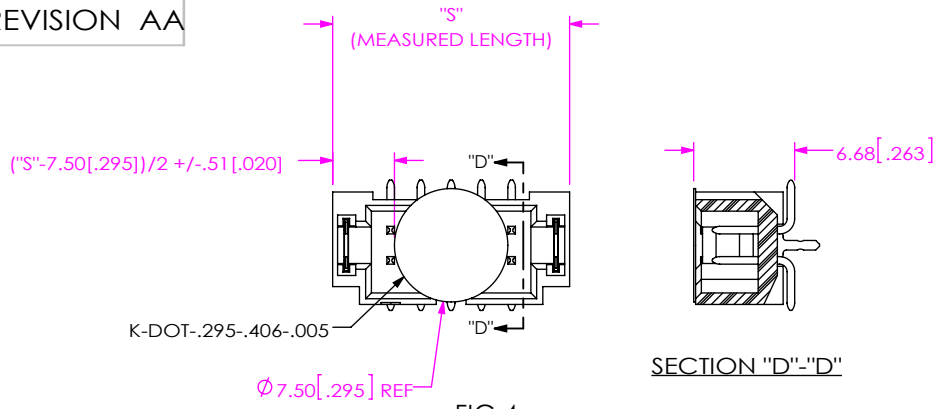

FIG 4
T2M-105-01-X-D-SM-K SHOWN
(FOR SURFACE MOUNT OPTION ONLY)

PACKAGING
ALL PARTS ARE LOADED WITH POSITIONS 1
TOWARDS ARROW

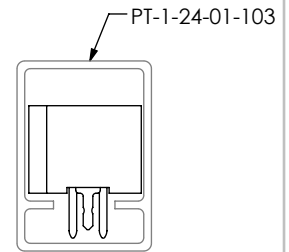
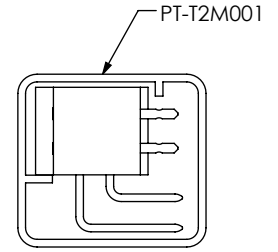
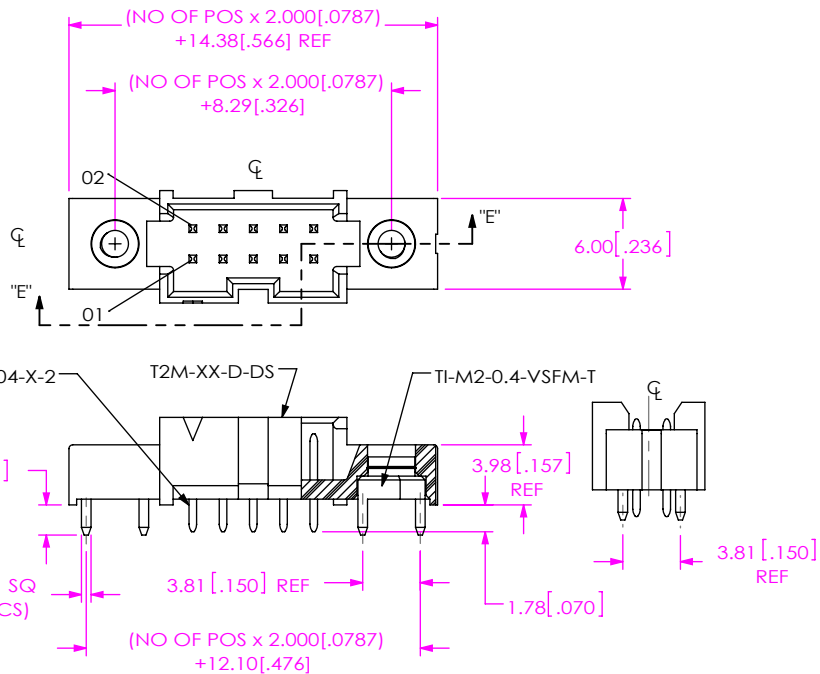
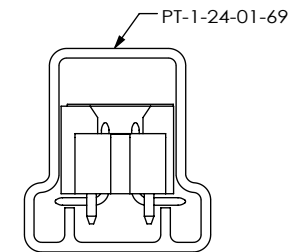
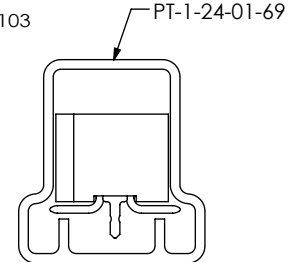
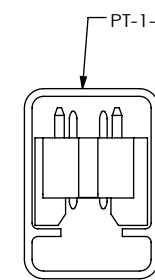

TABLE 1		
OPTIONS	PACKAGING TUBE	PLUG
-TH, -TH-WT	PT-1-24-01-103	TP-09
-SM, -SM-WT	PT-1-24-01-69	TP-09
-RA, -RA-WT	PT-T2M001	TP-07
-TH-DS	PT-1-24-01-103	TP-09
-SM-DS	PT-1-24-01-69	TP-09



SECTION "E"-"E"

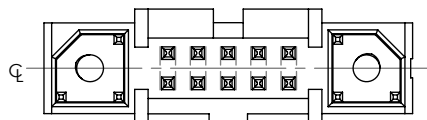
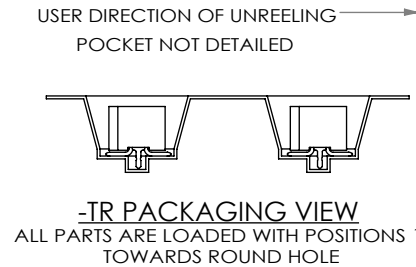
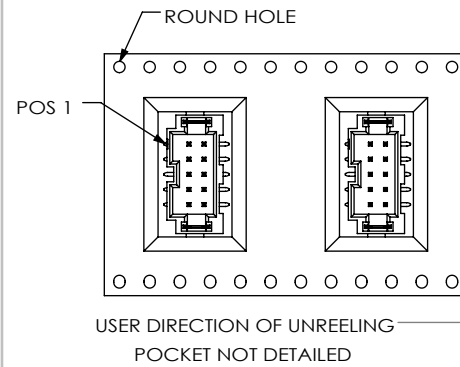

FIG 6
T2M-105-01-X-D-TH-DS SHOWN
(SAME AS FIG 1, EXCEPT AS SHOWN)
(ONLY AVAILABLE WITH -TH & -SM OPTION)



PROPRIETARY NOTE
THIS DOCUMENT CONTAINS CONFIDENTIAL AND PROPRIETARY INFORMATION AND ALL DESIGN, MANUFACTURING, REPRODUCTION, USE, PATENT RIGHTS AND SALES RIGHTS ARE EXPRESSLY RESERVED BY SAMTEC, INC. THIS DOCUMENT SHALL NOT BE DISCLOSED, IN WHOLE OR PART, TO ANY UNAUTHORIZED PERSON OR ENTITY NOR REPRODUCED, TRANSFERRED OR INCORPORATED IN ANY OTHER PROJECT IN ANY MANNER WITHOUT THE EXPRESS WRITTEN CONSENT OF SAMTEC, INC.

DO NOT SCALE DRAWING

SHEET SCALE: 2:1



520 PARK EAST BLVD, NEW ALBANY, IN 47150
PHONE: 812-944-6733 FAX: 812-948-5047
e-Mail info@SAMTEC.com code 55322

DESCRIPTION: 2mm SHROUDED TERMINAL STRIP
DWG. NO. T2M-1XX-XX-X-D-XX-XX

BY: J. BORGELT 3/23/09 SHEET 3 OF 3