



Chipsmall Limited consists of a professional team with an average of over 10 year of expertise in the distribution of electronic components. Based in Hongkong, we have already established firm and mutual-benefit business relationships with customers from,Europe,America and south Asia,supplying obsolete and hard-to-find components to meet their specific needs.

With the principle of “Quality Parts,Customers Priority,Honest Operation,and Considerate Service”,our business mainly focus on the distribution of electronic components. Line cards we deal with include Microchip,ALPS,ROHM,Xilinx,Pulse,ON,Everlight and Freescale. Main products comprise IC,Modules,Potentiometer,IC Socket,Relay,Connector.Our parts cover such applications as commercial,industrial, and automotives areas.

We are looking forward to setting up business relationship with you and hope to provide you with the best service and solution. Let us make a better world for our industry!



Contact us

Tel: +86-755-8981 8866 Fax: +86-755-8427 6832

Email & Skype: info@chipsmall.com Web: www.chipsmall.com

Address: A1208, Overseas Decoration Building, #122 Zhenhua RD., Futian, Shenzhen, China



AM/FM Receiver IC

Description

The T4258 is an integrated AM/FM frontend circuit in BICMOS technology. It contains a double conversion system for FM and an up-/down conversion circuit for AM (IF1 = 10.7 MHz, IF2 = 450 kHz). A complete automatically aligned high performance AM/FM tuner

can be built together with the PLL U4256BM. This ICs are designed for high performance car radio applications. Electrostatic sensitive device. Observe precautions for handling.

Features

- Receiving condition analyzer
- Integrated band filter for 2nd IF; with software controlled bandwidth
- Pin compatible with U4255BM
- FM-double conversion system
- World tuner, US Weatherband, J-band
- Completely integrated FM demodulator
- Soft mute and multipath noise cancellation
- AM up-/down conversion system
- AM stereo capability
- Stop signal generation for AM and FM
- Automatic alignment possible
- 3-wire bus controlled

Block Diagram

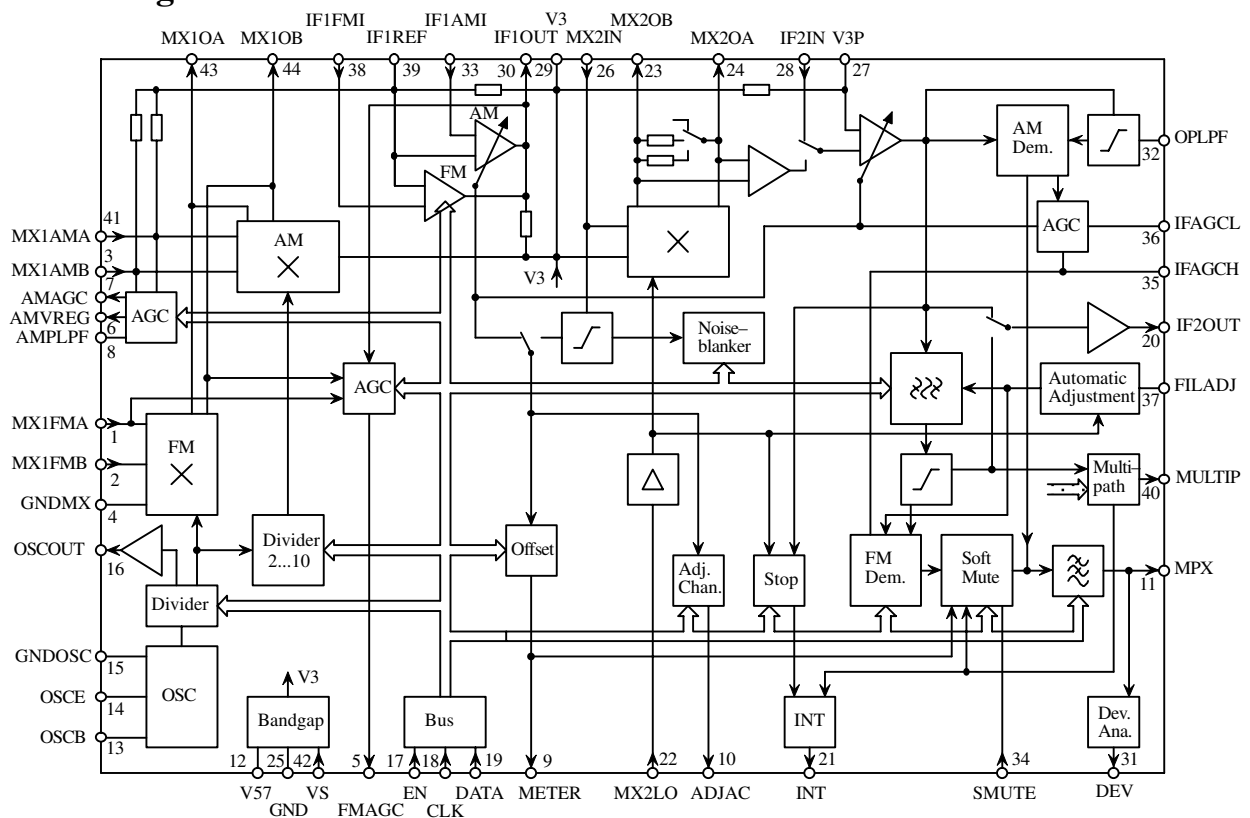

Figure 1. Block diagram

Ordering Information

Extended Type Number	Package	Remarks
T4258-ILQ	SSO44	Taped and reeled
T4258-ILS	SSO44	Tube

Pin Description

Pin	Symbol	Function
1	MX1FMA	1st mixer FM input A
2	MX1FMB	1st mixer FM input B
3	MX1AMB	1st mixer AM input B
4	GNDMX	Ground 1st mixer
5	FMAGC	FM preamplifier AGC
6	AMVREG	AM control voltage
7	AMAGC	AM preamplifier AGC
8	AMPLPF	AM AGC LP filter
9	METER	Fieldstrength output
10	ADJAC	Adjacent channel detection output
11	MPX	Multiplex signal
12	V57	5.7 V reference voltage
13	OSCB	Oscillator basis
14	OSCE	Oscillator emitter
15	GNDOSC	Oscillator ground
16	OSCOU	Oscillator output
17	EN	3-wire bus enable
18	CLK	3-wire bus clock
19	DATA	3-wire bus data
20	IF2OUT	2nd IF amplifier output
21	INT	Interrupt, stop signal, test out
22	MX2LO	10.25 MHz input for 2nd mixer
23	MX2OB	2nd mixer output B
24	MX2OA	2nd mixer output A
25	GND	Ground
26	MX2IN	2nd mixer input
27	V3P	3 V ref. for AMPIN, AMIFAGC, Control, IF2IN
28	IF2IN	2nd IF amplifier input
29	V3	3 V reference for IF1OUT, MX2IN
30	IF1OUT	1st IF amplifier output
31	DEV	Deviation detect output
32	OPLPF	Operating point LPF
33	IF1AMI	1st IF AM amplifier input
34	SMUTE	Soft MUTE control input
35	IFAGCH	IF AGC LP filter high time constant constant
36	IFAGCL	IF AGC LP filter low time constant
37	FILADJ	Filter adjust
38	IF1FMI	1st IF FM amplifier input
39	IF1REF	1st IF & MX1OUT ref., MX1AMA, MX1AMB
40	MULTIP	Multipath detection output
41	MX1AMA	1st mixer AM input A
42	VS	Supply voltage
43	MX1OA	1st mixer output A
44	MX1OB	1st mixer output B

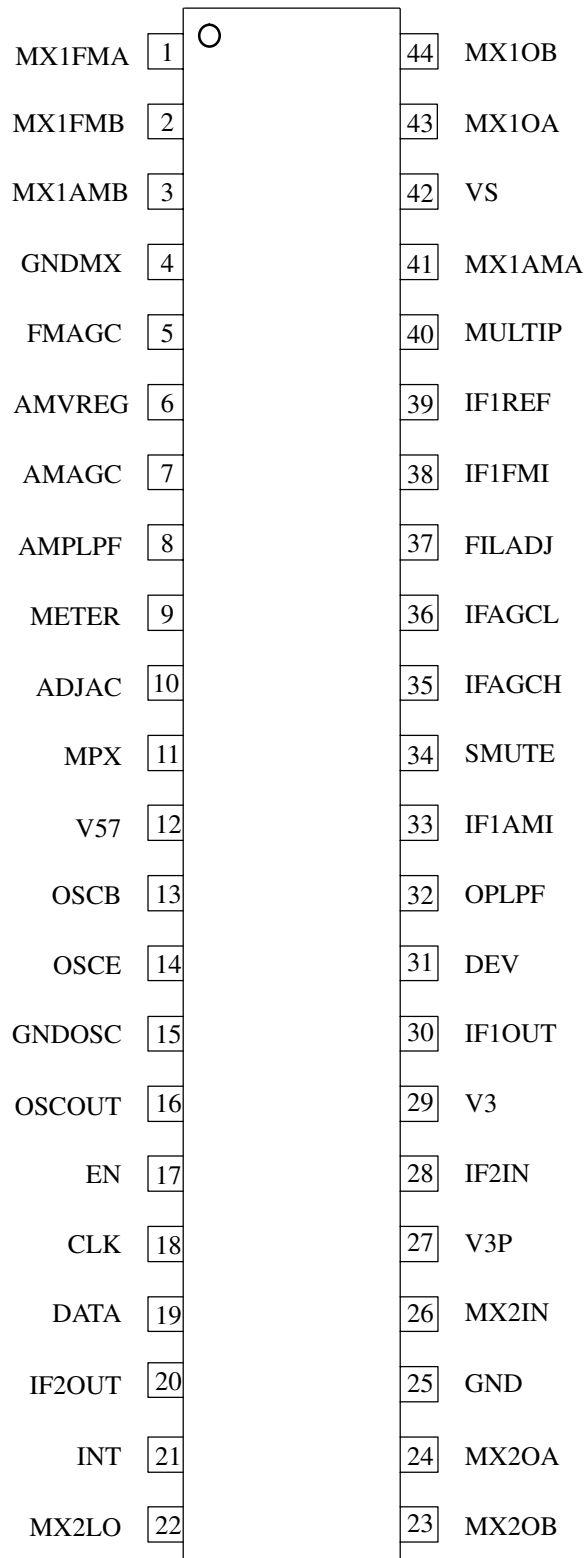

Figure 2. Pinning SSO44

Absolute Maximum Ratings

All voltages are referred to GND (Pin 25)

Parameter	Symbol	Value	Unit
Supply voltage Pin 42	V_S	10	V
Power dissipation	P_{tot}	1,0	W
Junction temperature	T_j	150	°C
Ambient temperature range	T_{amb}	-40 to +85	°C
Storage temperature range	T_{stg}	-50 to +150	°C

Operating Range

All voltages are referred to GND (Pin 25)

Parameter	Symbol	Min.	Typ.	Max.	Unit
Supply voltage range Pin 42	V_S	8	8.5	10	V
Ambient temperature	T_{amb}	-40		85	°C

Thermal Resistance

Parameter	Symbol	Value	Unit
Junction ambient soldered to PCB	R_{thJA}	t.b.d.	K/W

Electrical Characteristics

Test conditions (unless otherwise specified): $V_S = +8.5$ V, $T_{amb} = +25$ °C

for AC parameters: $f_{RF} = 1$ MHz, $R_g = 50$ Ω, $f_{MOD} = 0.4$ kHz, $m = 0.3$, $f_{IF} = 450$ kHz, reference point Pin 4

Parameter	Test Conditions / Pins	Symbol	Min.	Typ.	Max.	Unit
Supply voltage	Pin 42	V_S		8.5	10	V
Supply current	Pin 42	I_S			100	mA
AM RF AGC						
AGC threshold Mixer Input	(2 bit)			91 94 97 100		dbμV dbμV dbμV dbμV
AM LO divider						
Programmable divider	(3 bit)	N	2		10	
AM Mixer (10.7 MHz)						
DC supply current	Pin 43 + 44			17		mA
Conversion conductance i_{oif}/v_{iif}		S_{m1}		4.1		mA/V
Maximum IF output	Pins 43, 44	V_{oIF}		8		V_{pp}
Input intercept point 3rd order		IP3		133		dBμV
Input resistance	10 MHz Pin 41			13		kΩ

Electrical Characteristics (continued)

Test conditions (unless otherwise specified): $V_S = +8.5\text{ V}$, $T_{amb} = +25^\circ\text{C}$

for AC parameters: $f_{RF} = 1\text{ MHz}$, $R_g = 50\ \Omega$, $f_{MOD} = 0.4\text{ kHz}$, $m = 0.3$, $f_{IF} = 450\text{ kHz}$, reference point Pin 4

Parameter	Test Conditions / Pins	Symbol	Min.	Typ.	Max.	Unit
AM-1st IF Amplifier (10.7 MHz)						
Input resistance	Pin 33	R_i		100		$k\Omega$
IF preamplifier gain	$R_L = 330\ \Omega$ Pins 33 to 30	G		15		dB
Preamplifier control range				26		dB
Output intercept point 3rd order		IP3		137		$\text{dB}\mu\text{V}$
Noise figure		F		10		dB
Mixer 2 (450 kHz)						
DC supply current	Pin 23 + 24			10		mA
Conversion conductance i_{oif2}/v_{iif1}		S_{m2}		2		mA/V
Maximum IF output	Pins 23, 24	V_{OIF}		8		V_{pp}
Output impedance	Pin 23 – GND Pin 24 – GND	R_o C_o		1 3		$M\Omega$ pF
Input intercept point 3rd order		IP3		133		$\text{dB}\mu\text{V}$
Input resistance		R_i		330		Ω
2nd IF Amplifier (450 kHz)						
Input resistance	Pin 28	R_i		3		$k\Omega$
IF preamplifier gain	Pin 28 to 20	G		53		dB
Preamplifier control range				47		dB
IF2 Output (Pin 20)						
Output level				200		mV
Oscillator						
Oscillator amplitude	R_g (Pin 13) = 220 Ω , Q of $L_{osc} = 70$	V_{LOB} V_{LOE} V_{LObuf}	70	160 100 90	220	mV mV mV
Frequency range		f_{OSC}	70		260	MHz
Harmonics	Pin 16				-15	dBc
Output resistance	Pin 16	R_{LObuf}		70		Ω
Programmable oscillator divider	Range FM Europe FM Japan AM WB	Nosc	1	2 3 2 1.5	3	

Electrical Characteristics

Test conditions (unless otherwise specified): $V_S = +8.5\text{ V}$, $T_{\text{amb}} = +25^\circ\text{C}$, for AC parameters: $f_{\text{RF}} = 100\text{ MHz}$, $R_g = 50\ \Omega$, $f_{\text{MOD}} = 0.4\text{ kHz}$, $\Delta f = \pm 75\text{ kHz}$, $f_{\text{IF}} = 450\text{ kHz}$, reference point Pin 4

Parameter	Test Conditions / Pins	Symbol	Min.	Typ.	Max.	Unit
FM AGC						
AGC threshold mixer input	(2 bit)	Vmixin		85 90 95 103		dB μ V dB μ V dB μ V dB μ V
AGC threshold mixer output		Vmix-out		t.b.d.		dB μ V
AGC threshold IF amp. out		Vif1out		t.b.d.		dB μ V
FM Mixer						
Conversion transconductance		g_c		7		mA/V
3rd order intercept point	Load impedance: $R_{L43,44} = 200\ \Omega$	IP3		125		dB μ V
Noise figure		NF _{dsb}		10		dB
Input resistance	Pin 1 to 2	$R_{i1,2}$				k Ω
Input capacitance	Pin 1 to 2	$C_{i1,2}$		5		pF
Input 1 resistance to ground	f = 100 MHz Pin 1	R_{i1}				k Ω
Input 1 capacitance to ground	f = 100 MHz Pin 1	C_{i1}		9		pF
Input 2 resistance to ground	f = 100 MHz Pin 2	R_{i2}				k Ω
Input 2 capacitance to ground	f = 100 MHz Pin 2	C_{i2}		7		pF
Output capacitance to GND	Pins 43, 44	$C_{o43},$ C_{o44}		5		pF
1st IF FM Amplifier						
Digitally adjustable gain	3 bit, 10.7 MHz	G_{min} G_{max}		20 30		dB dB
Input resistance	Pin 38	R_{i38}		330		Ω
Output resistance	Pin 30	R_{o30}		330		Ω
Temperature coefficient of the gain	Bit 66 = 0	TK1				dB/K
Temperature coefficient of the gain	Bit 66 = 1	TK2				dB/K
Noise figure		F		t.b.d.		dB
Output intercept point 3rd order		IP3		130		dB μ V

Electrical Characteristics (continued)

Test conditions (unless otherwise specified): $V_S = +8.5\text{ V}$, $T_{amb} = +25^\circ\text{C}$, for AC parameters: $f_{RF} = 100\text{ MHz}$, $R_g = 50\ \Omega$, $f_{MOD} = 0.4\text{ kHz}$, $\Delta f = \pm 75\text{ kHz}$, $f_{IF} = 450\text{ kHz}$, reference point Pin 4

Parameter	Test Conditions / Pins	Symbol	Min.	Typ.	Max.	Unit
FM Demodulator (Pin 11)						
Output voltage	$V_{iPin\ 23, 24} = 40\text{ mV}$ $f = 450\text{ kHz}$ Deviation = $\pm 22.5\text{ kHz}$, $f_{MOD} = 1\text{ kHz}$	V_{MPX} , Pin 11		150		mV
Signal-to-noise related to 22.5 kHz dev.	Bandwidth = 30 Hz .. 20 kHz Deemphasis 50 μs	S/N		60		dB
Total distortion	Bandwidth 2nd IF filter = 120 kHz			0.3		%
WB Demodulator (Pin 11)						
Output voltage	Bit 71 = 0, Bit 72 = 1 $V_{iPin\ 23, 24} = 40\text{ mV}$ $f = 450\text{ kHz}$ Deviation = $\pm 2.5\text{ kHz}$, $f_{MOD} = 1\text{ kHz}$	V_{MPX} , Pin 11		165		mV
Total distortion	Bandwidth 2nd IF filter = 30 kHz			3.5		%
Fieldstrength Output (Pin 10) (Bit 80 = 0)						
Range				85		dB
Max. output voltage				5		V
Steepness				50		mV/dB
Integrated IF filter						
Bandwidth	FM (4 bit) WB (4 bit)		50 20		200 100	kHz kHz
Centerfrequency adjust			-43		+43	kHz
MPX Lowpass						
Bandwidth	Bit 79 = 0 Bit 79 = 1			90 180		kHz kHz
Stopsignal Generator						
Stop Window			± 0.5		± 80	kHz

Electrical Characteristics (continued)

Parameter	Test Conditions / Pins	Symbol	Min.	Typ.	Max.	Unit
3-wire bus, ENABLE, Clock, DATA Pins 17, 18, 19						
Input voltage High		V_{BUS}	2.0			V
LOW		V_{BUS}			1.0	V
Clock frequency					1.0	MHz
Period of CLK High		t_H	250			ns
Low		t_L	250			ns
Rise time EN, DA, CLK		t_R			400	ns
Fall time EN, DA, CLK		t_F			100	ns
Set-up time		t_S	100			ns
Hold time EN		t_{HEN}	250			ns
Hold time DA		t_{HDA}	0			ns

Bus Timing

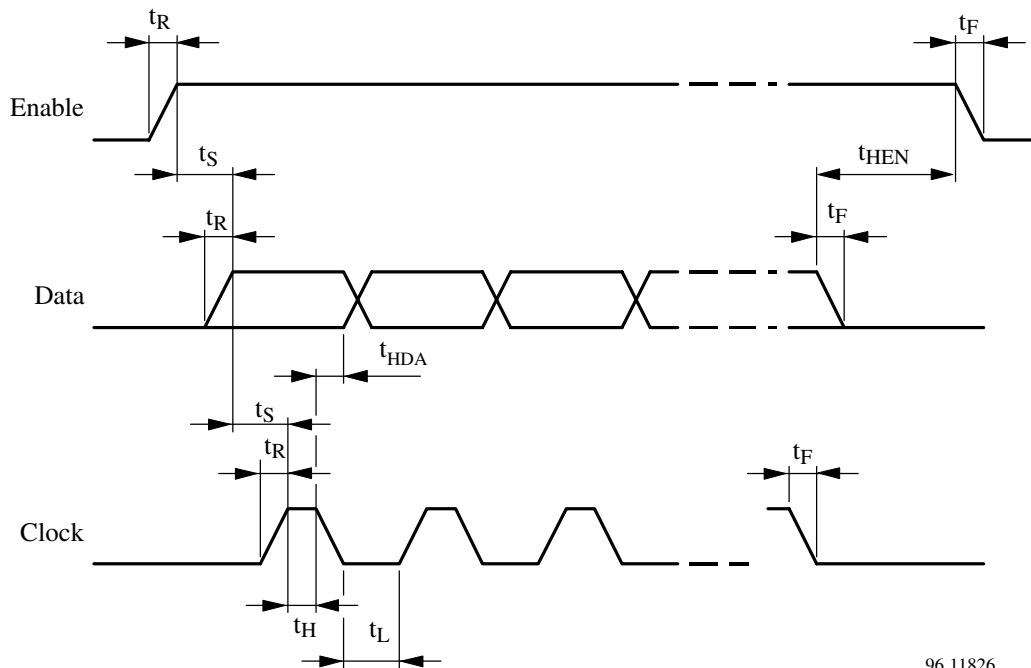

Figure 3. Bus timing

96 11826

Data Transfer

A24_100																										
MSB			BYTE3				LSB		MSB	BYTE2						LSB	MSB	BYTE1						LSB		
ADDR.			Demodulator		Gain FM – IF1				Pin21 INT	Search stop window/ Noiseblanker AM sensitivity			Local OSC AM divider/ Multipath sensitivity			Pin9 Meter	Pin11 MPX LPF	Stop signal gate time								
1	0	0	1=AM	1=FM					1=stop										1=nband	0=90kHz						
			B93	B92	B91	B90	B89	B88	B87	B86	B85	B84	B83	B82	B81	B80	B79	B78	B77	B76	B75	B74	B73			
A24_101																										
MSB			BYTE3				LSB		MSB	BYTE 2		LSB	MSB	BYTE1						LSB						
ADDR.			WB demodulator gain		Soft mute threshold				Soft mute depth	TK FM IF1 ampl.	AGC threshold AM/FM	1st IF ampl. AM/FM	1st Mixer +AGC AM/FM	Pin23/ Pin24 MX2O band-width	Int. IF2 reference shift			Pin 20 IFOUT	Pin28 IF2IN	Demodulator control	Gain local OSC					
1	0	1							1=26dB			1=AM	1=AM										0=IF2out	0=open	0=active	0=low
			B72	B71	B70	B69	B68	B67	B66	B65	B64	B63	B62	B61	B60	B59	B58	B57	B56	B55	B54	B53	B52			
A24_111																										
MSB			BYTE 3	LSB	MSB	BYTE 2		LSB	MSB	BYTE 1	LSB															
ADDR.			Local OSC AGC	Do not change	Pin 9 offset	Bandpath filter center frequency			Pin 9 Meter	Local OSC AGC prescaler (VCO(Buffer))																
1	1	1	0	0	0	0	0	0	0	0	0								1=+multi							
			B30	B29	B28	B27	B26	B25	B24	B23	B22	B21	B20	B19	B18	B17	B16	B15	B14	B13	B12	B11	B10			

A8_100								
MSB			BYTE 1				LSB	
ADDR.			Test-mode	Multipath noise cancellation		Pin 11 MPX OUT	Pin 40/10 Reset	Noise blanker AM
1	0	0	0	0=on		1=Mute	0	1=on
			B9	B8		B7	B6	B5

A8_101								
MSB			BYTE 1				LSB	
ADDR.			Pin 21 INT		Bandpath filter Band width			
1	0	1	1=ON					
			B4		B3	B2	B1	B0

Pulse Diagram

8-bit command

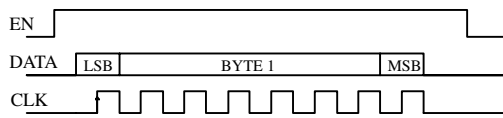

16-bit command

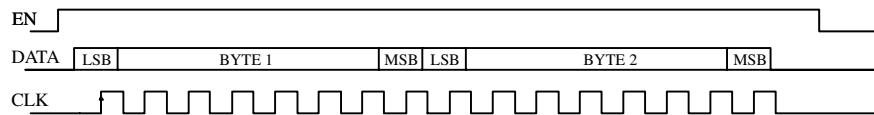

24-bit command

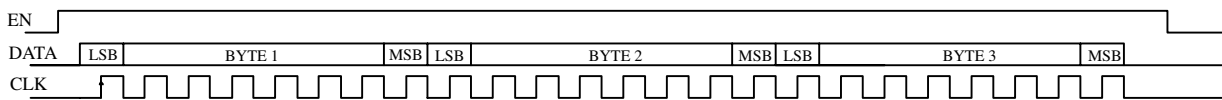

Figure 4. Pulse diagram

Bus Control

The operating mode is set by the bits 92 and 93

AM/ FM/ Weather Channel	Bit 93	Bit 92
Standby	0	0
FM	0	1
AM	1	0
Weather band	1	1

The bits 89 to 91 control the gain of the FM IF amplifier

Gain FM-IF	Bit 91	Bit 90	Bit 89
19 dB	0	0	0
21 dB	0	0	1
23 dB	0	1	0
25 dB	0	1	1
27 dB	1	0	0
28 dB	1	0	1
29 dB	1	1	0
30 dB	1	1	1

Bit 88 switches the search mode on/off

Station search	Bit 88
Receive	0
Search	1

Bits 85 to 87 select the the search-stop deviation from the center frequency and AM noiseblanker sensitivity

AM Noise-blanker Sensitivity	Search-stop window \pm	Bit 87	Bit 86	Bit 85
Low	0.5 kHz	0	0	0
	1.1 kHz	0	0	1
	2.3 kHz	0	1	0
Normal	4.8 kHz	0	1	1
	10 kHz	1	0	0
	20 kHz	1	0	1
High	40 kHz	1	1	0
	80 kHz	1	1	1

In AM mode (Bits 92, 93), Bits 81 to 84 set the divide factor of the AM divider

Divider AM Mixer 1	Bit 93	Bit 92	Bit 84	Bit 83	Bit 82	Bit 81
Divide by 10	1	0	1	X	X	X
Divide by 9	1	0	0	1	1	1
Divide by 8	1	0	0	1	1	0
Divide by 7	1	0	0	1	0	1
Divide by 6	1	0	0	1	0	0
Divide by 5	1	0	0	0	1	1
Divide by 4	1	0	0	0	1	0
Divide by 3	1	0	0	0	0	1
Divide by 2	1	0	0	0	0	0

In FM mode and in weather band mode (Bit 92, 93), the Bits 81 to 84 set the multipath sensitivity

Sensitivity Multipath	Bit 93	Bit 92	Bit 84	Bit 83	Bit 82	Bit 81
Off	x	1	0	0	0	0
Low	x	1	0	0	0	1
	x	1	0	0	1	0
	x	1	0	0	1	1
	x	1	0	1	0	0
	x	1	0	1	0	1
	x	1	0	1	1	0
Normal	x	1	0	1	1	1
	x	1	1	0	0	0
	x	1	1	0	0	1
	x	1	1	0	1	0
	x	1	1	0	1	1
	x	1	1	1	0	0
	x	1	1	1	0	1
	x	1	1	1	1	0
High	x	1	1	1	1	1

Bit 80 and Bit 13 switches between narrow band field strength information and wide band field strength information

Field strength narrow band / wide band	Bit 80	Bit 13
FM field strength (wide band)	0	1
Wide Band + Multipath fieldstrength	0	0
AM field strength from AGC (narrow band)	1	1
Narrow band + Multipath fieldstrength	1	0

Bit 79 controls the band width of the low pass filter of the MPX output

Band Width MPX Low Pass Filter	Bit 79
90 kHz	0
180 kHz	1

The stop counter calculates an average center frequency during the time which is set by the bits 73 to 78

Time Window for Stop Signal	Bit 78	Bit 77	Bit 76	Bit 75	Bit 74	Bit 73
3.1969 ms	0	0	0	0	0	0
1 x 3.1969 ms	0	0	0	0	0	1
...						
63 x 3.1969 ms	1	1	1	1	1	1

The demodulator gain for the weather band mode is set by the bits 71 and 72

Demodulator Gain in Weather Band Mode	Bit 72	Bit 71
5 x	0	0
7.5 x	0	1
10 x	1	0
15 x	1	1

For soft mute, the MPX signal level will be reduced depending on the input signal strength. Bits 68 to 70 set the input signal field strength, at which the MPX signal will be reduced by 3 dB (for soft mute). The setting of fieldstrength offset (Bit 18 ... 21) has also influence of the soft start.

Start Soft Mute	Bit 70	Bit 69	Bit 68
0 dB	0	0	0
1 dB	0	0	1
2 dB	0	1	0
3 dB	0	1	1
4 dB	1	0	0
5 dB	1	0	1
6 dB	1	1	0
7 dB	1	1	1

Bit 67 sets the maximum reduction of the MPX signal level

Max. Value of Soft Mute	Bit 67
30 dB	0
26 dB	1

Temperature coefficient setting of FM IF–amplifier

Temperature Coefficient (TC) of the IF Amplifier	Bit 66
TK 1	0
TK 2	1

Level control of the FM / WB – AGC threshold

FM AGC Threshold	Bit 65	Bit 64	Bit 62
103 dBμV	0	0	0
97 dBμV	0	1	0
92 dBμV	1	0	0
85 dBμV	1	1	0

Level control of AM-AGC threshold

AM Control Start	Bit 65	Bit 64	Bit 62
91dBμV	0	0	1
94 dBμV	0	1	1
97 dBμV	1	0	1
100 dBμV	1	1	1

Bits 60 and 61 controls the band width of the 2nd-mixer output tank, in FM mode

FM Band Width Mixer 2	Bit 61	Bit 60
150 kHz	0	0
200 kHz	0	1
250 kHz	1	0
450 kHz	1	1

Bit 62 select which 1st mixer and AGC stage in active

	Bit 62
FM mixer + FM AGC active	0
AM mixer + AM AGC active	1

Bit 63 controls which 1st IF amplifier is active

	Bit 63
1st FM – IF amplifier active	0
1st AM – IF amplifier active	1

Setting of the internal second IF reference shift

IF Offset	Bit 59	Bit 58	Bit 57	Bit 56
+ 0.00 kHz	0	0	0	0
+ 6.25 kHz	0	0	0	1
+ 12.50 kHz	0	0	1	0
+ 18.75 kHz	0	0	1	1
+ 25.00 kHz	0	1	0	0
+ 31.25 kHz	0	1	0	1
+ 37.50 kHz	0	1	1	0
+ 43.75 kHz	0	1	1	1
– 0.00 kHz	1	0	0	0
– 6.25 kHz	1	0	0	1
– 12.50 kHz	1	0	1	0
– 18.75 kHz	1	0	1	1
– 25.00 kHz	1	1	0	0
– 31.25 kHz	1	1	0	1
– 37.50 kHz	1	1	1	0
– 43.75 kHz	1	1	1	1

Function of Pin 20 setting is done by Bit 55

Pin 20: IF out / Field Strength for Multipath	Bit 55
2nd IF output	0
Multipath field strength	1

Band filter, in FM mode

2nd IF Filter	Bit 54
Internal filter	0
External + internal filter	1

Setting Bit 53 controls the demodulator in FM/ WB mode.

Demodulator Control	Bit 53
FM fine tuning OFF (default)	1
WB fine tuning	0

Setting Bit 52 controls the gain of the local oscillator.

Local Oscillator	Bit 52
Low gain	0
High gain	1

Bit 30 controls the oscillator AGC

Oscillator AGC	Bit 30
AGC of (default)	0
AGC on	1

Setting of the fieldstrength offset (Output Pin 9)

Offset Field-strength	Bit 21	Bit 20	Bit 19	Bit 18
0.0 dB	0	0	0	0
0.5 dB	0	0	0	1
1.0 dB	0	0	1	0
1.5 dB	0	0	1	1
2.0 dB	0	1	0	0
2.5 dB	0	1	0	1
3.0 dB	0	1	1	0
3.5 dB	0	1	1	1
4.0 dB	1	0	0	0
4.5 dB	1	0	0	1
5.0 dB	1	0	1	0
5.5 dB	1	0	1	1
6.0 dB	1	1	0	0
6.5 dB	1	1	0	1
7.0 dB	1	1	1	0
7.5 dB	1	1	1	1

Setting Bit 17 controls the center frequency OFFSET of the integrated bandpath filter's center frequency.

Offset Center Frequency	Bit 17
Offset +	0
Offset -	1

Setting the OFFSET of the integrated bandpath filter center frequency.

Offset Center Frequency	Bit 17	Bit 16	Bit 15	Bit 14
0.00 kHz		0	0	0
6.25 kHz		0	0	1
12.50 kHz		0	1	0
18.75 kHz		0	1	1
25.00 kHz		1	0	0
31.25 kHz		1	0	1
37.50 kHz		1	1	0
43.75 kHz		1	1	1

Setting the local oscillator prescaler (VCO/ Buffer)

Prescaler VCO	Prescaler Buffer	Bit 12	Bit 11	Bit 10
1	1	X	0	0
1.5	3	0	0	1
1.5	1.5	1	0	1
2	2	X	1	0
3	3	X	1	1

Setting Bit 9 (expert mode) activates test mode (B18 – B23 active)

Mode	Bit 9
Normal mode	0
Test mode	1

Bit 8 = 0 activates the multipath noise canceller

Multipath Noise Canceller	Bit 8
Active	0
Not active	1

Bit 7 = 1 mutes the MPX output

Mute of MPX Output	Bit 7
MPX out, Pin 11	0
Mute MPX	1

Bit 6 = 1 resets the Multipath sensor and the adjacent channel sensor

Sensor out (Pin 10, 40)	Bit 6
Normal	0
To ground	1

Bit 5 switches the AM noiseblinker ON/OFF

AM Noiseblinker	Bit 5
OFF	0
ON	1

Bits 0 to 3 set the band width of the integrated 2nd IF band filter

IF Bandwidth	Bit 3	Bit 2	Bit 1	Bit 0
200 kHz	0	0	0	0
190 kHz	0	0	0	1
180 kHz	0	0	1	0
170 kHz	0	0	1	1
160 kHz	0	1	0	0
150 kHz	0	1	0	1
140 kHz	0	1	1	0
130 kHz	0	1	1	1
120 kHz	1	0	0	0
110 kHz	1	0	0	1
100 kHz	1	0	1	0
90 kHz	1	0	1	1
80 kHz	1	1	0	0
70 kHz	1	1	0	1
60 kHz	1	1	1	0
50 kHz	1	1	1	1

Test Circuit

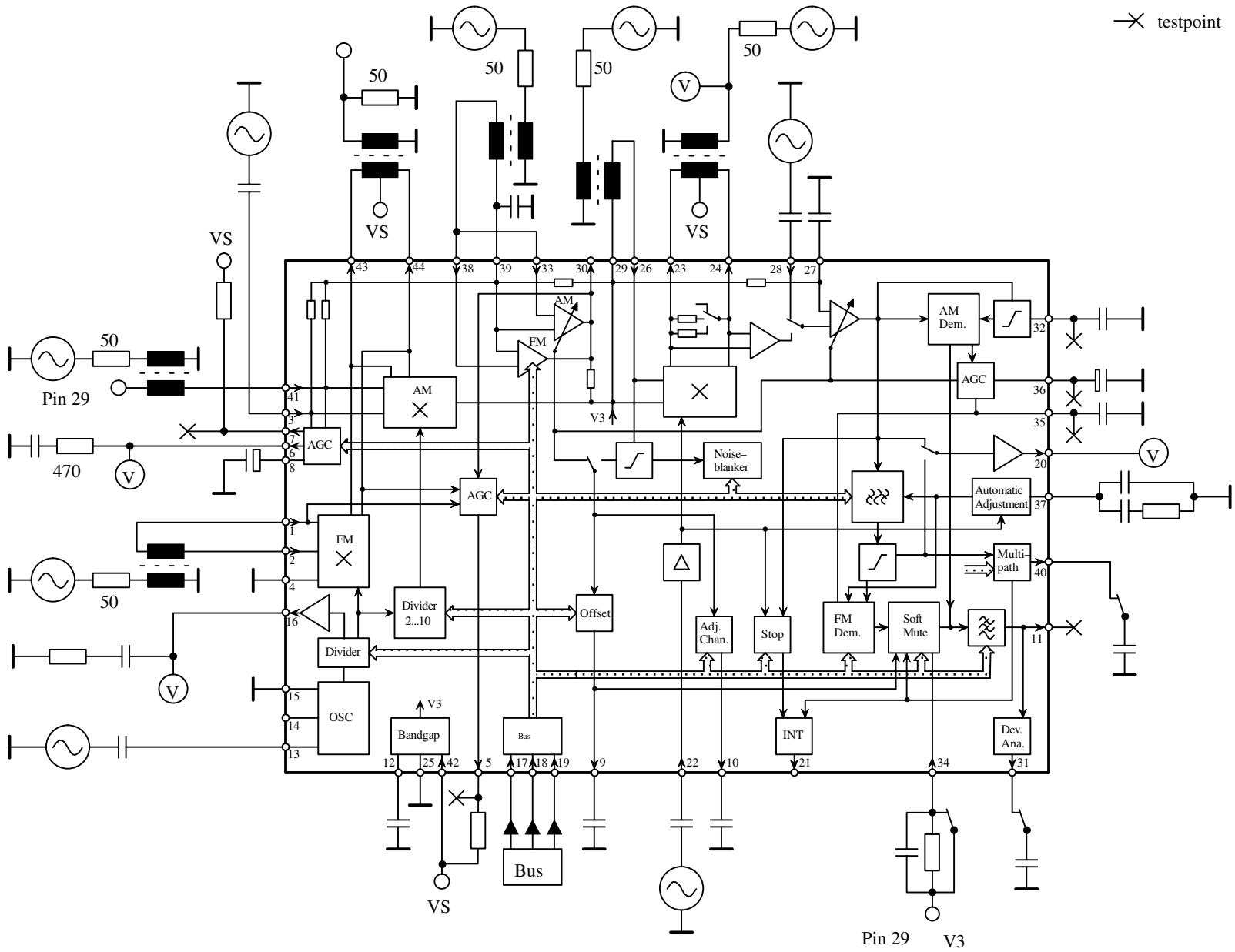

Figure 5. Test circuit

Application Board Schematic

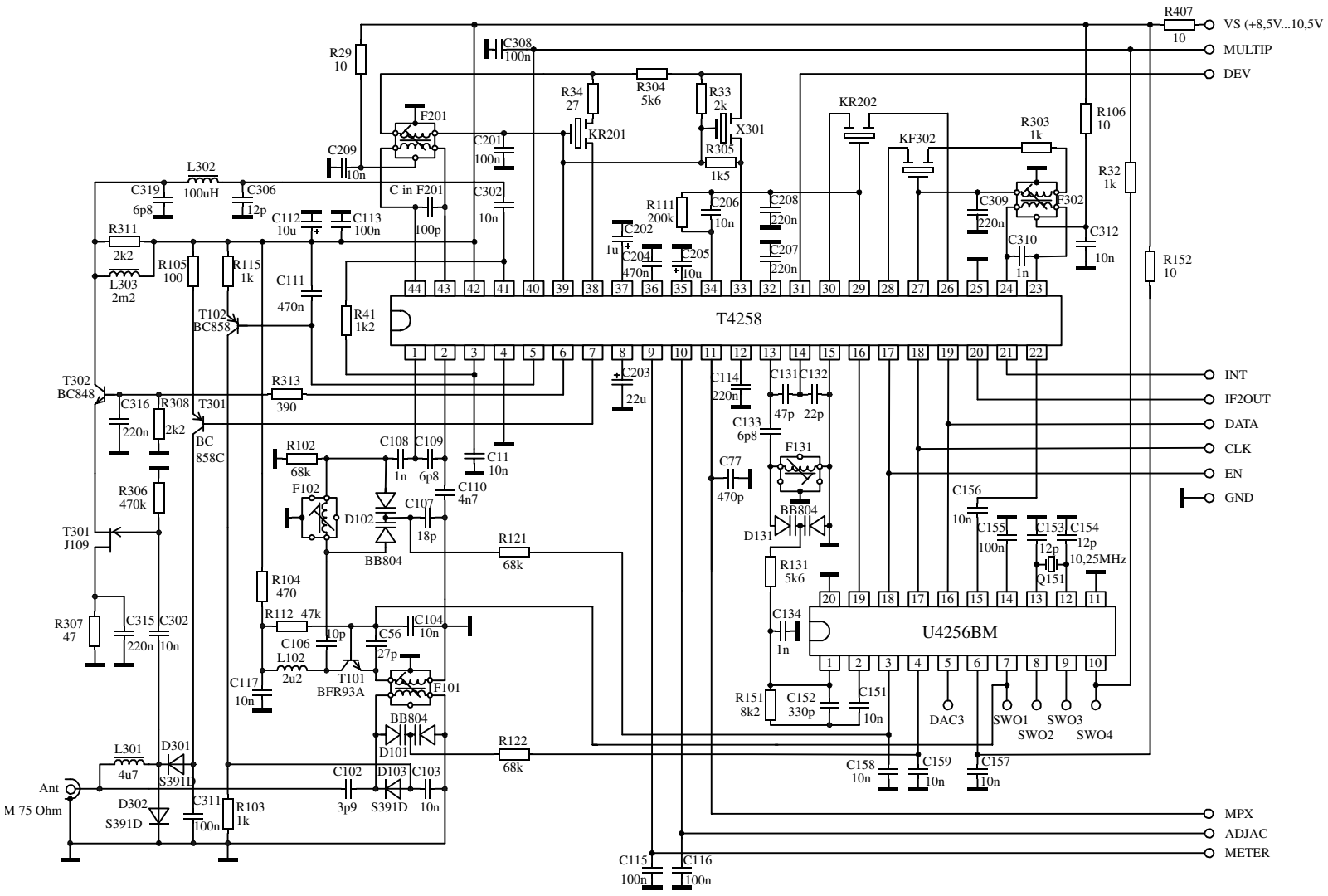
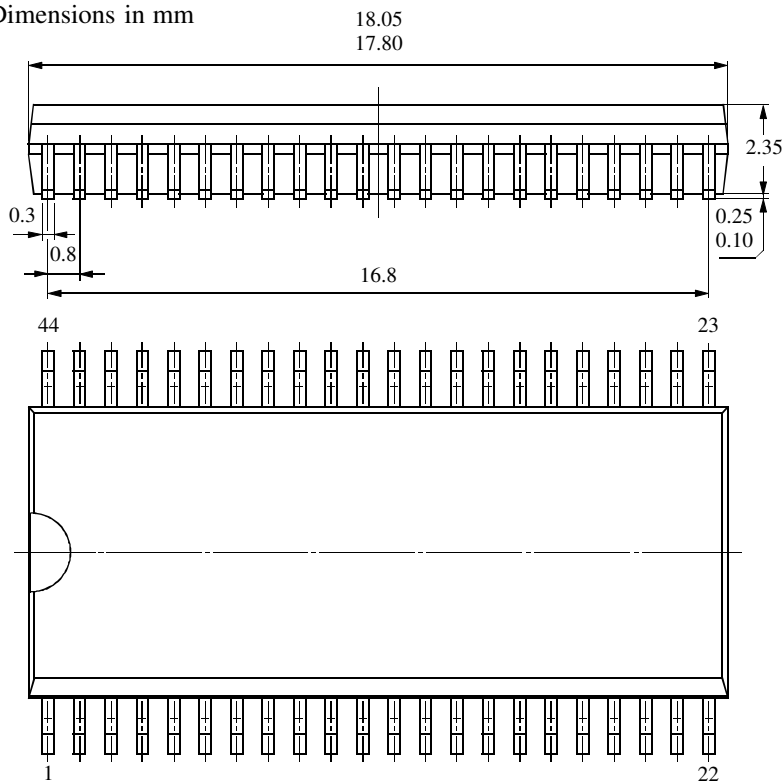

Figure 6. Application board schematic

Package Dimensions

Package SSO44

Dimensions in mm



technical drawings
according to DIN
specifications

Ozone Depleting Substances Policy Statement

It is the policy of **Atmel Germany GmbH** to

1. Meet all present and future national and international statutory requirements.
2. Regularly and continuously improve the performance of our products, processes, distribution and operating systems with respect to their impact on the health and safety of our employees and the public, as well as their impact on the environment.

It is particular concern to control or eliminate releases of those substances into the atmosphere which are known as ozone depleting substances (ODSs).

The Montreal Protocol (1987) and its London Amendments (1990) intend to severely restrict the use of ODSs and forbid their use within the next ten years. Various national and international initiatives are pressing for an earlier ban on these substances.

Atmel Germany GmbH has been able to use its policy of continuous improvements to eliminate the use of ODSs listed in the following documents.

1. Annex A, B and list of transitional substances of the Montreal Protocol and the London Amendments respectively
2. Class I and II ozone depleting substances in the Clean Air Act Amendments of 1990 by the Environmental Protection Agency (EPA) in the USA
3. Council Decision 88/540/EEC and 91/690/EEC Annex A, B and C (transitional substances) respectively.

Atmel Germany GmbH can certify that our semiconductors are not manufactured with ozone depleting substances and do not contain such substances.

We reserve the right to make changes to improve technical design and may do so without further notice.

Parameters can vary in different applications. All operating parameters must be validated for each customer application by the customer. Should the buyer use Atmel Wireless & Microcontrollers products for any unintended or unauthorized application, the buyer shall indemnify Atmel Wireless & Microcontrollers against all claims, costs, damages, and expenses, arising out of, directly or indirectly, any claim of personal damage, injury or death associated with such unintended or unauthorized use.

Data sheets can also be retrieved from the Internet: <http://www.atmel-wm.com>

Atmel Germany GmbH, P.O.B. 3535, D-74025 Heilbronn, Germany
Telephone: 49 (0)7131 67 2594, Fax number: 49 (0)7131 67 2423