



Chipsmall Limited consists of a professional team with an average of over 10 year of expertise in the distribution of electronic components. Based in Hongkong, we have already established firm and mutual-benefit business relationships with customers from,Europe,America and south Asia,supplying obsolete and hard-to-find components to meet their specific needs.

With the principle of “Quality Parts,Customers Priority,Honest Operation,and Considerate Service”,our business mainly focus on the distribution of electronic components. Line cards we deal with include Microchip,ALPS,ROHM,Xilinx,Pulse,ON,Everlight and Freescale. Main products comprise IC,Modules,Potentiometer,IC Socket,Relay,Connector.Our parts cover such applications as commercial,industrial, and automotives areas.

We are looking forward to setting up business relationship with you and hope to provide you with the best service and solution. Let us make a better world for our industry!



Contact us

Tel: +86-755-8981 8866 Fax: +86-755-8427 6832

Email & Skype: info@chipsmall.com Web: www.chipsmall.com

Address: A1208, Overseas Decoration Building, #122 Zhenhua RD., Futian, Shenzhen, China



Key Features

- 2dBi gain
- Quad band GSM and 3G compatible
- IP67 rated
- Rugged and durable
- Through hole mount
- Rubber seal gasket



General Description

The TANGO17 is a tough, virtually destruction proof, IP67 rated quadband GSM and 3G antenna. The antenna has a gain of 2dBi and a V.S.W.R of <2.0. Fitted with a through hole mount threaded nut, ensures a secure fit to its surface.

This antenna is designed for applications where it is going to be exposed to 'passers-by' or the public so a vandal/theft proof solution is a necessity. With its 19.7mm M20 thread, the antenna can be securely fastened to its surface. The rubber seal is tough enough to withstand industrial washes on mobile applications such as trucks or buses.

Measuring at just 34.8 x 68 ø mm (height x diameter) offers a relatively low profile solution. This, with its discreet design helps it remain unnoticed.

Moisture Proof

The device should satisfy the electrical characteristics specified in the table 'Key Specifications - Dielectric Antenna' after exposed to the temperature 40±2°C and the relative humidity 90~95% RH for 96 hours and 1~2 hours recovery time under normal condition.

Vibration Resist

The device should satisfy the electrical characteristics specified in the table 'Key Specifications - Dielectric Antenna' after applied to the vibration of 10 to 55MHz with amplitude of 1.5mm for 2 hours each in X, Y, and Z directions.

Drop Shock

The device should satisfy the electrical characteristics specified in the table 'Key Specifications - Dielectric Antenna' after dropping onto the hard wooden board from the height of 30cm for 3 times each facet of the 3 dimensions of the device.

High Temperature Endurance

The device should satisfy the electrical characteristics specified in the table 'Key Specifications - Dielectric Antenna' after exposed to the temperature 80±5°C for 24±2 hours and 1~2 hours recovery time under normal temperature.

Low Temperature Endurance

The device should satisfy the electrical characteristics specified in the table 'Key Specifications - Dielectric Antenna' after exposed to the temperature -40±5°C for 24±2 hours and 2 hours recovery time under normal temperature.

Temperature Cycle Test

The device should satisfy the electrical characteristics specified in the table 'Key Specifications - Dielectric Antenna' after exposed to the low temperature -25°C and high temperature +85°C for 30±2 minutes each by 5 cycles and 1~2 hours recovery time under normal temperature.

Rev 1.2

Key Specifications - Electrical

Frequency range:	824 ~ 960MHz 1710 ~ 2170MHz
V.S.W.R:	<2.0
Polarization:	Linear
Gain:	2.0dBi (Zenith)
Impedance:	50ohm

Gain

GSM

850MHz:	3.41dBi
900MHz:	-0.08dBi
1800MHz:	-2.46dBi
1900MHz:	-5.45dBi

3G

2100MHz:	-1.87dBi
----------	----------

Key Specifications - Mechanical

Cable:	RG174 or others
Connector:	SMA or others
Material:	ABS
Mounting method:	Screw

Key Specifications - Environmental

Operating temperature:	-40 to +85°C
Relative humidity:	Up to 95%
Ingress protection:	IP67 (exclude cable outlet)
Vibration:	10 to 55Hz with 1.5mm amplitude 2 hours
Environmentally friendly:	RoHS compliant

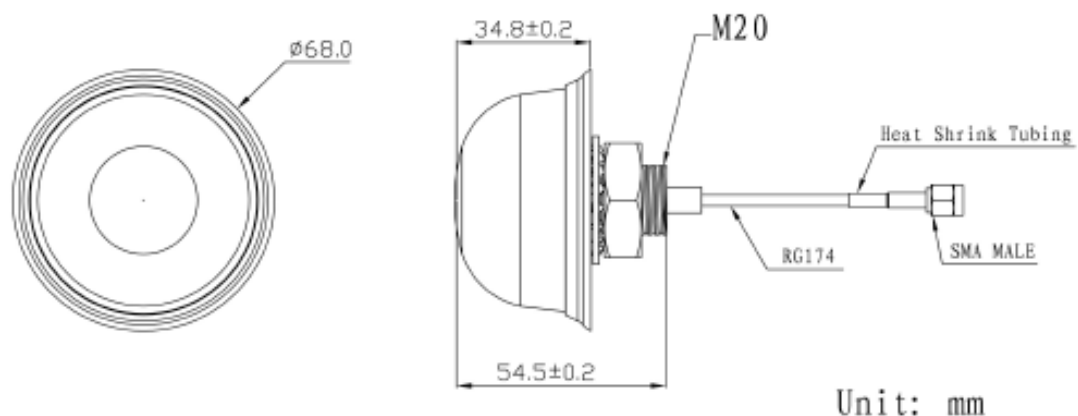

Gain vs. Frequency Graph

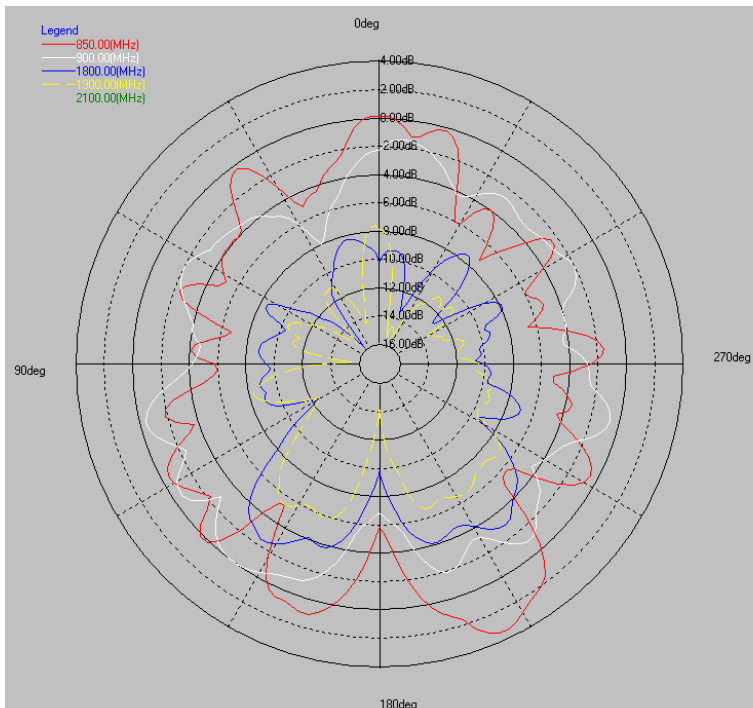

UL Tested (Basingstoke, UK)
Part: TANGO17