



Chipsmall Limited consists of a professional team with an average of over 10 year of expertise in the distribution of electronic components. Based in Hongkong, we have already established firm and mutual-benefit business relationships with customers from,Europe,America and south Asia,supplying obsolete and hard-to-find components to meet their specific needs.

With the principle of "Quality Parts,Customers Priority,Honest Operation,and Considerate Service",our business mainly focus on the distribution of electronic components. Line cards we deal with include Microchip,ALPS,ROHM,Xilinx,Pulse,ON,Everlight and Freescale. Main products comprise IC,Modules,Potentiometer,IC Socket,Relay,Connector.Our parts cover such applications as commercial,industrial, and automotives areas.

We are looking forward to setting up business relationship with you and hope to provide you with the best service and solution. Let us make a better world for our industry!



Contact us

Tel: +86-755-8981 8866 Fax: +86-755-8427 6832

Email & Skype: info@chipsmall.com Web: www.chipsmall.com

Address: A1208, Overseas Decoration Building, #122 Zhenhua RD., Futian, Shenzhen, China



Specification

Small Form Factor Pluggable

Duplex LC Receptacle – SFP+

Optical Transceivers

10 Gigabit Ethernet

8G Fiber Channel



Ordering Information

TAS-A1TH1-P11

Model Name	Voltage	Category	Device type	Interface	LOS	Temperature	Distance	Latch Color
TAS-A1TH1-P11	3.3V	With DDMI	850 nm VCSEL	AC / AC Coupling	LVTTL	0°C~+70°C	33m / 82m /300m (OM1/ OM2/OM3)	Black

Features

- Optical interface compliant to IEEE 802.3ae 10GBASE-SR/SW
- 850nm VCSEL TOSA and PIN ROSA
- Maximum link length of 300m on 2000MHz-km MMF
- LC duplex receptacle
- Low power dissipation (<800 mW)
- Hot Pluggable
- All-metal housing for superior EMI performance
- Built in digital diagnostic functions
- Operating case temperature range: 0 ~ 70°C
- RoHS Compliant
- Electrical Interface Compliant to SFF-8431 Specifications for Enhanced 8.5 And 10 Gigabit Small Form Factor Pluggable Module “SFP+”
- Fibre Channel Physical Interface-4 Specification (FC-PI-4 Rev. 8.00)”. American National. Standard for Information Systems, May 21, 2008.

Applications

- High-speed storage area networks
- Computer cluster cross-connect
- Custom high-speed data pipes
- Inter Rack Connection
- Multi-Rate 8.5/10.312 Gb/s Fibre Channel

Fiber type	Minimum modal bandwidth @ 850 nm (MHz•km)	Operating range (meters)
62.5 µm MMF	160	2 to 26
	200	2 to 33
50 µm MMF	400	2 to 66
	500	2 to 82
	2000	2 to 300

Transceiver Block Diagram

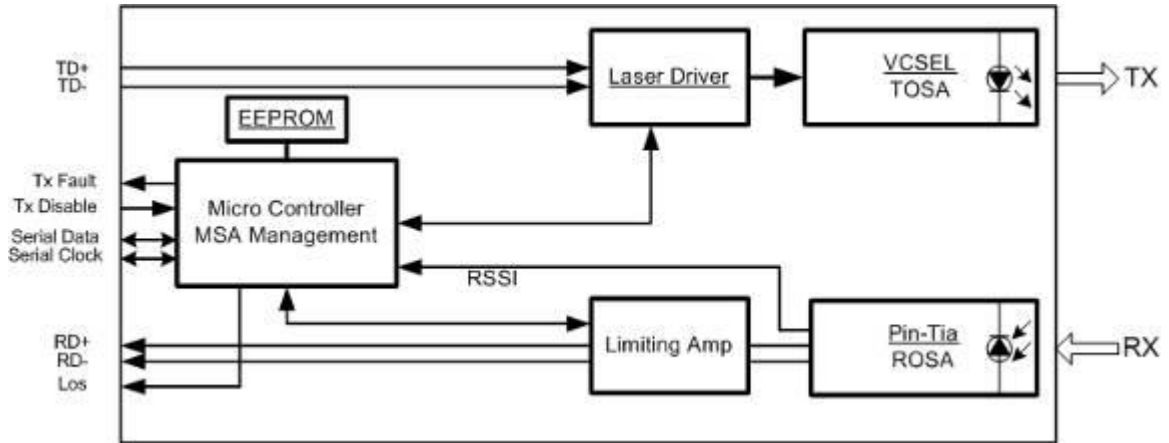

Proposed Applications Schematics

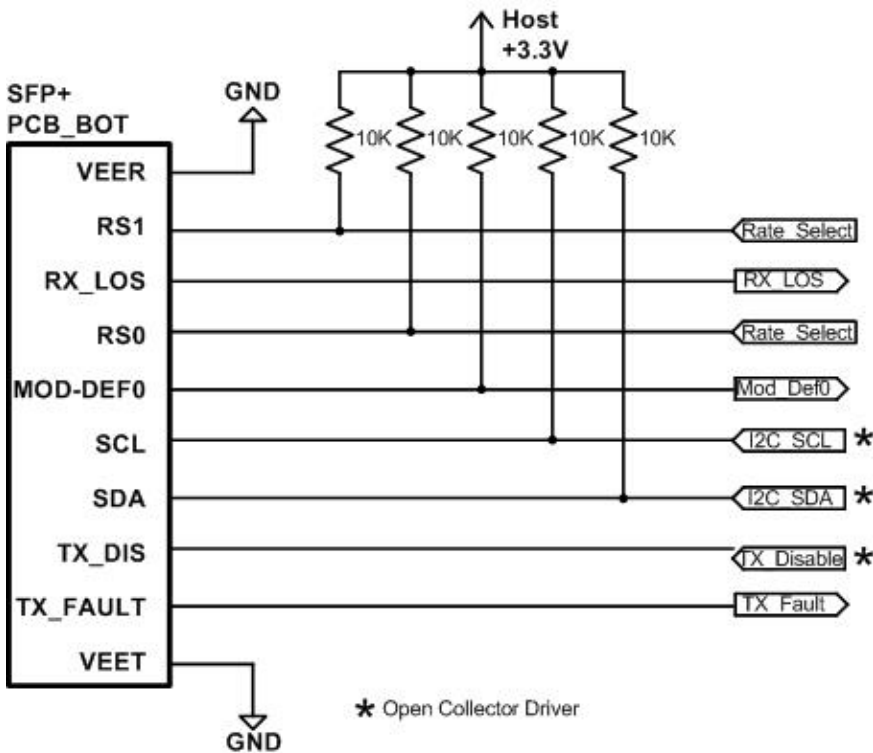
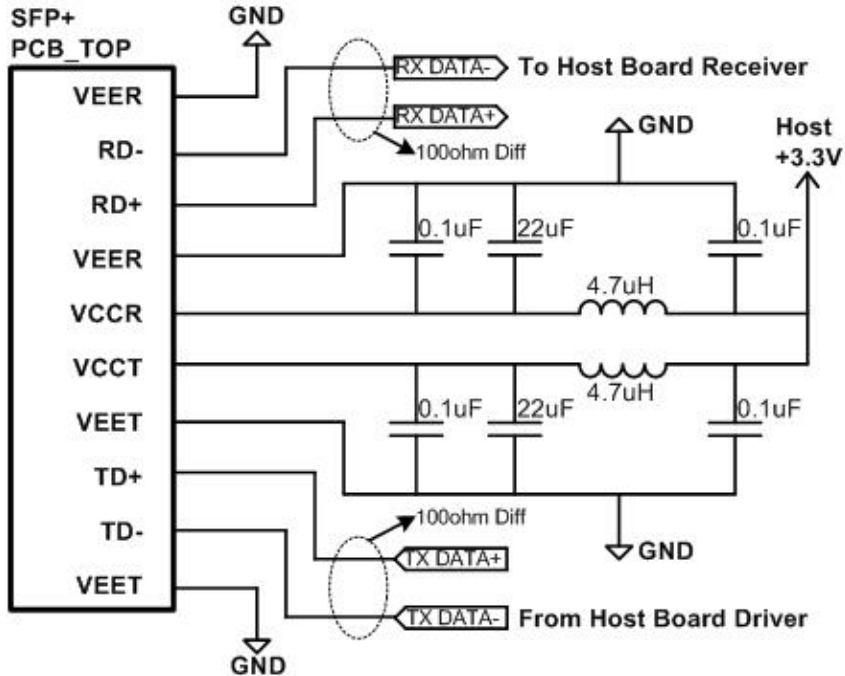

Pin Definition and Descriptions

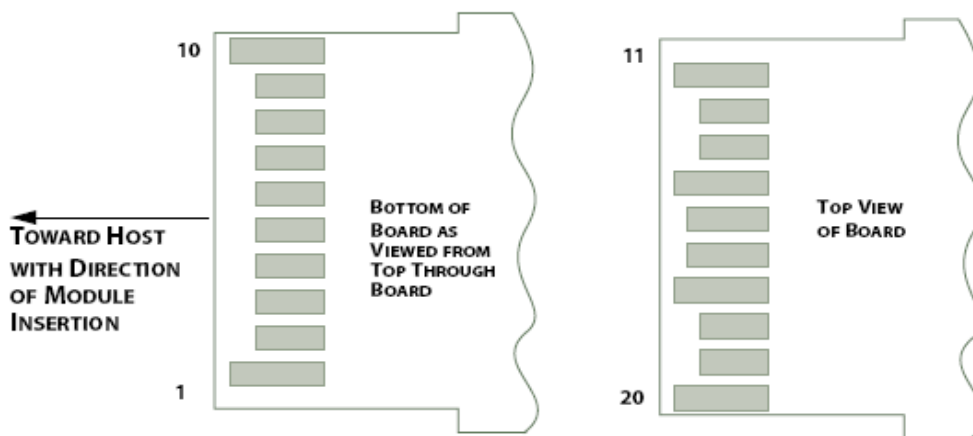
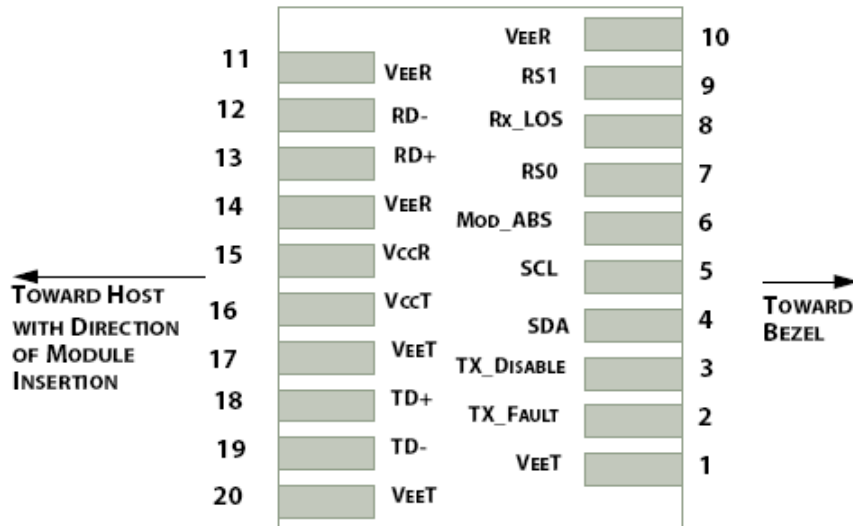

PIN	Logic	Symbol	Name / Description	Note
1		VeeT	Module Transmitter Ground	1
2	LVTTL-O	TX_Fault	Module Transmitter Fault	2
3	LVTTL-I	TX_Dis	Transmitter Disable; Turns off transmitter laser output	3
4	LVTTL-I/O	SDA	2-Wire Serial Interface Data Line	
5	LVTTL-I	SCL	2-Wire Serial Interface Clock	
6		Mod_ABS	Module Absent, connected to VeeT or VeeR in the module	2
7	LVTTL-I	RS0	Rate Select 0, optionally controls SFP+ module receiver. When high input signaling rate > 4.25 GBd and when low input signal rate \leq 4.25 GBd.	
8	LVTTL-O	RX_LOS	Receiver Loss of Signal Indication	2
9	LVTTL-I	RS1	Rate Select 1, optionally controls SFP+ module transmitter. When high input signaling rate > 4.25 GBd and when low input signal rate \leq 4.25 GBd.	
10		VeeR	Module Receiver Ground	1
11		VeeR	Module Receiver Ground	1
12	CML-O	RD-	Receiver Inverted Data Output	
13	CML-O	RD+	Receiver Data Output	
14		VeeR	Module Receiver Ground	1
15		VccR	Module Receiver 3.3 V Supply	
16		VccT	Module Transmitter 3.3 V Supply	
17		VeeT	Module Transmitter Ground	1
18	CML-I	TD+	Transmitter Non-Inverted Data Input	
19	CML-I	TD-	Transmitter Inverted Data Input	
20		VeeT	Module Transmitter Ground	1

Note:

1. Module ground pins are isolated from the module case and chassis ground within the module.
2. Shall be pulled up with 4.7k to 10k ohm to a voltage between 3.15V and 3.45V on the host board.
3. Shall be pulled up with 4.7k to 10k ohm to VccT in the module.

Absolute Maximum Ratings

Parameters	Symbol	Min.	Max.	Unit
Power Supply Voltage	V_{CC}	0	3.6	V
Storage Temperature	T_C	-40	85	°C
Relative Humidity	RH	5	95	%
Optical Receiver Power (Damage)		-	4	dBm

Recommended Operating Environment

Parameters	Symbol	Min.	Typical	Max	Unit
Power Supply Voltage	V_{CC}	3.135	3.3	3.465	V
Operating Case Temperature	T_C	0	25	70	°C

Optical Characteristics

The following optical characteristics are defined over the Recommended Operating Environment unless otherwise specified.

Parameter	Symbol	Min.	Typical	Max	Unit	Notes
Transmitter						
Center Wavelength	λ_t	840	850	860	nm	
RMS spectral width	Pm			Note 1	nm	
Average Optical Power @10Gb/s	Pavg	-6.5		-1	dBm	
Average Optical Power @8.5Gb/s	Pavg	-8.2		-2	dBm	
Optical Power OMA	Poma			Note 1	dBm	
Laser Off Power	Poff			-30	dBm	
Extinction Ratio	ER	3.5			dB	
Transmitter Dispersion Penalty @10Gb/s	TDP			3.9	dB	
Transmitter Dispersion Penalty @8.5Gb/s	TDP			4.2	dB	
Relative Intensity Noise	Rin			-128	dB/Hz	12dB reflection
Optical Return Loss Tolerance				12	dB	
Receiver						
Center Wavelength	λ_r	840	850	860	nm	
Receiver Sensitivity (OMA) @10Gb/s	Psens			-11.1	dBm	
Receiver Sensitivity (OMA) @8.5Gb/s	Psens			-11.2	dBm	
Los Assert	LosA	-30			dBm	
Los Dessert	LosD			-12	dBm	
Los Hysteresis	LosH	0.5			dB	
Overload	Pin			-1	dBm	
Receiver Reflectance				-12	dB	

Note:

- Trade-offs are available between spectral width, center wavelength and minimum OMA, as shown in follow table.

Center Wavelength (nm)	RMS Spectral width (nm)								
	Up to 0.05	0.05 to 0.1	0.1 to 0.15	0.15 to 0.2	0.2 to 0.25	0.25 to 0.3	0.3 to 0.35	0.35 to 0.4	0.4 to 0.45
840 to 842	-4.2	-4.2	-4.1	-4.1	-3.9	-3.8	-3.5	-3.2	-2.8
842 to 844	-4.2	-4.2	-4.2	-4.1	-3.9	-3.8	-3.6	-3.3	-2.9
844 to 846	-4.2	-4.2	-4.2	-4.1	-4.0	-3.8	-3.6	-3.3	-2.9
846 to 848	-4.3	-4.2	-4.2	-4.1	-4.0	-3.8	-3.6	-3.3	-2.9
848 to 850	-4.3	-4.2	-4.2	-4.1	-4.0	-3.8	-3.6	-3.3	-3.0
850 to 852	-4.3	-4.2	-4.2	-4.1	-4.0	-3.8	-3.6	-3.4	-3.0
852 to 854	-4.3	-4.2	-4.2	-4.1	-4.0	-3.9	-3.7	-3.4	-3.1
854 to 856	-4.3	-4.3	-4.2	-4.1	-4.0	-3.9	-3.7	-3.4	-3.1
856 to 858	-4.3	-4.3	-4.2	-4.1	-4.0	-3.9	-3.7	-3.5	-3.1
858 to 860	-4.3	-4.3	-4.2	-4.2	-4.1	-3.9	-3.7	-3.5	-3.2

Digital Diagnostic Functions

The following digital diagnostic characteristics are defined over the Recommended Operating Environment unless otherwise specified. It is compliant to SFF8472 Rev10.2 with internal calibration mode. For external calibration mode please contact our sales staff.

Parameter	Symbol	Min.	Max	Unit	Notes
Temperature monitor absolute error	DMI_Temp	-3	3	degC	Over operating temp
Laser power monitor absolute error	DMI_TX	-3	3	dB	
RX power monitor absolute error	DMI_RX	-3	3	dB	-1dBm to -12dBm range
Supply voltage monitor absolute error	DMI_VCC	-0.08	0.08	V	Full operating range
Bias current monitor	DMI_Ibias	-10%	10%	mA	

Electrical Characteristics

The following electrical characteristics are defined over the Recommended Operating Environment unless otherwise specified.

Parameter	Symbol	Min.	Typical	Max	Unit	Notes
Data Rate		8.5		10.3125	Gbps	
Power Consumption			600	800	mW	
Transmitter						
Single Ended Output Voltage Tolerance		-0.3		4	V	
C common mode voltage tolerance		15			mV	
Tx Input Diff Voltage	VI	180		700	mV	
Tx Fault	VoL	-0.3		0.4	V	At 0.7mA
Data Dependent Input Jitter	DDJ			0.1	UI	
Data Input Total Jitter	TJ			0.28	UI	
Receiver						
Single Ended Output Voltage Tolerance		-0.3		4	V	
Rx Output Diff Voltage	Vo	300		850	mV	
Rx Output Rise and Fall Time	Tr/Tf	30			ps	20% to 80%
Total Jitter	TJ			0.7	UI	
Deterministic Jitter	DJ			0.42	UI	

Control And Status I/O Timing Characteristics

Timing characteristics of control and status I/O are included in Table 9, which is also defined in SFF-8431.

Parameter	Symbol	Min	Max	Unit	Condition
TX Disable Assert Time	t _{off}		10	μs	Time from rising edge of TX Disable to when the optical output falls below 10% of nominal
TX Disable Negate Time	t _{on}		1	ms	Time from falling edge of TX Disable to when the modulated optical output rises above 90% of nominal
Time to initialize, including reset of TX_Fault	t _{init}		300	ms	From power on or negation of TX Fault using TX Disable
TX Fault Assert Time	t _{fault}		100	μs	Time from fault to TX fault on.
TX Disable to reset	t _{reset}	10		μs	Time TX Disable must be held high to reset TX_fault
LOS Assert Time	t _{loss_on}		100	μs	Time from LOS state to RX LOS assert
LOS Deassert Time	t _{loss_off}		100	μs	Time from non-LOS state to RX LOS deassert
Rate-Select Change Time	t _{ratesel}		10	μs	Time from rising or falling edge of Rate Select input until receiver bandwidth is in conformance with appropriate specification.
Serial ID Clock Rate	f _{serial_clock}		100	kHz	

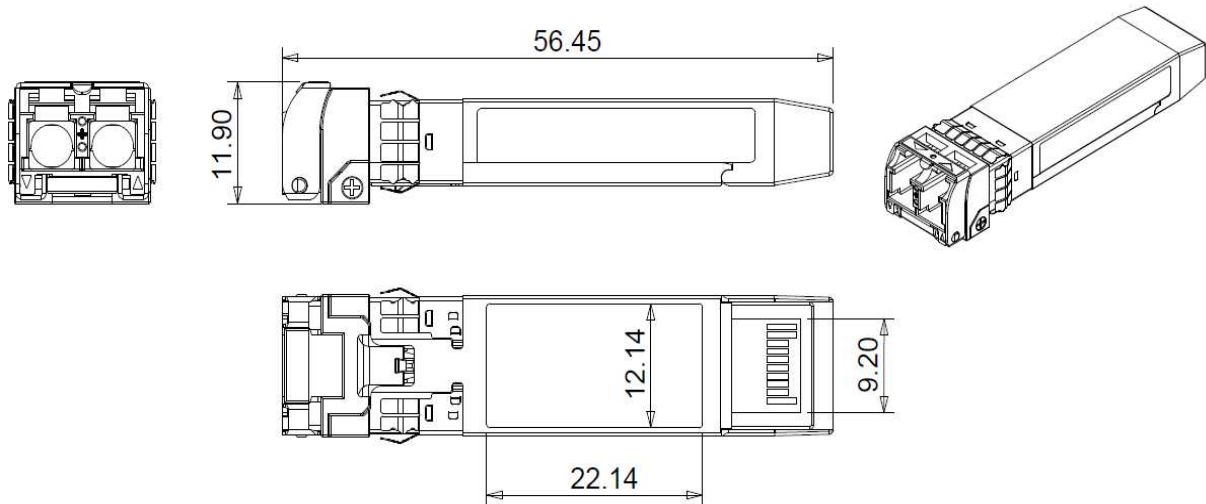
Mechanical (mm)**ESD**

This transceiver is specified as ESD threshold 2kV for all electrical input pins, tested per MIL-STD-883, Method 3015.4 /JESD22-A114-A (HBM). However, normal ESD precautions are still required during the handling of this module. This transceiver is shipped in ESD protective packaging. It should be removed from the packaging and handled only in an ESD protected environment.

LASER Safety

This is a Class 1 Laser Product according to IEC 60825-1:1993:+A1:1997+A2:2001. This product complies with 21 CFR 1040.10 and 1040.11 except for deviations pursuant to Laser Notice No. 50, dated (July 26, 2001)