



Chipsmall Limited consists of a professional team with an average of over 10 year of expertise in the distribution of electronic components. Based in Hongkong, we have already established firm and mutual-benefit business relationships with customers from,Europe,America and south Asia,supplying obsolete and hard-to-find components to meet their specific needs.

With the principle of “Quality Parts,Customers Priority,Honest Operation,and Considerate Service”,our business mainly focus on the distribution of electronic components. Line cards we deal with include Microchip,ALPS,ROHM,Xilinx,Pulse,ON,Everlight and Freescale. Main products comprise IC,Modules,Potentiometer,IC Socket,Relay,Connector.Our parts cover such applications as commercial,industrial, and automotives areas.

We are looking forward to setting up business relationship with you and hope to provide you with the best service and solution. Let us make a better world for our industry!



## Contact us

Tel: +86-755-8981 8866 Fax: +86-755-8427 6832

Email & Skype: info@chipsmall.com Web: www.chipsmall.com

Address: A1208, Overseas Decoration Building, #122 Zhenhua RD., Futian, Shenzhen, China



## Basic Force Sensors

TBF Series, Compensated/Unamplified  
1 bar to 10 bar | 100 kPa to 1 MPa | 15 psi to 150 psi  
Millivolt Analog Output

**32315675**  
Issue A

Datasheet



### DESCRIPTION

Honeywell's TBF Series Force Sensors are small flush diaphragm pressure sensors designed for customers who require a simple device for applications where media compatibility and low trapped volume are important. The TBF Series has a precisely controlled diaphragm height, making these products useful in applications where force is applied by a flexible membrane to the sensor, such as infusion pumps. The sensor is internally unamplified, providing infinite resolution and allowing customers to do their own amplification in order to make use of the maximum resolution of the bare sensor output, leveraging any algorithm needed for the application. The sensor is internally temperature compensated and calibrated.

### VALUE TO CUSTOMERS

- Smallest package size in its class (7 mm x 7 mm x 3,89 mm) simplifies placement on crowded PCBs
- Widest pressure (1 bar to 10 bar | 100 kPa to 1 MPa | 15 psi to 150 psi) enables choice of optimum pressure range to maximize sensitivity
- Many different pressure ranges improve resolution and system accuracy
- Tight accuracy specification of  $\pm 0.15$  %FSS provides user with enhanced accuracy in the application
- Reliable supply chain
- Fast response for quotes and samples
- Designed to Six Sigma standards
- Manufacturing excellence
- Supports Lean manufacturing

### FEATURES

- Cost-effective sensor with many options
- Compensated/unamplified
- Wide operating temperature range (0 °C to 50 °C [32 °F to 122 °F])
- Low power consumption allows for potential use in battery operated applications
- Stable offset voltage
- Not sensitive to mounting orientation
- Small package size [7 mm x 7 mm x 3,89 mm]
- RoHS2 compliance

### POTENTIAL APPLICATIONS

#### Medical

- Drug delivery systems
- Infusion pumps
- Kidney dialysis machines
- Robotics
- Syringe pumps
- Wearables

### PORTFOLIO

The TBF Series joins the [1865 Series](#), [FSG Series](#), [FSS Series](#), [FSS-SMT Series](#) and [FSA Series](#).

# Basic Force Sensors, TBF Series, Compensated/Unamplified

**Table 1. Absolute Maximum Ratings<sup>1</sup>**

Characteristic	Min.	Max.	Unit
Supply voltage (V <sub>supply</sub> ) <sup>2</sup>	-12.0	12.0	Vdc
Storage temperature	-40 [-40]	125 [257]	°C [°F]
Soldering time peak reflow temperature	10 s max. at 240 °C [464 °F]		

<sup>1</sup>Absolute maximum ratings are the extreme limits the device will withstand without damage.

<sup>2</sup>Incorrect application of supply voltage or ground to the wrong pin may cause electrical failure.

**Table 2. Operating Specifications**

Characteristic	Min.	Typ.	Max.	Unit
Supply voltage (V <sub>supply</sub> ) <sup>1,2</sup>	1.5	5.0	12.0	Vdc
Supply current (at 5.0 Vdc supply)	-	0.6	1	mA
Operating temperature range <sup>3</sup>	0 [32]	—	50 [122]	°C [°F]
Compensated temperature range <sup>4</sup>	0 [32]	—	50 [122]	°C [°F]
Output resistance	—	2.5	-	kOhm

<sup>1</sup>Ratiometricity of the sensor (the ability of the device output to scale to the supply voltage) is achieved within the specified operating voltage.

<sup>2</sup>Incorrect application of supply voltage or ground to the wrong pin may cause electrical failure.

<sup>3</sup>Operating temperature range: The temperature range over which the sensor will produce an output proportional to force.

<sup>4</sup>Compensated temperature range: The temperature range over which the sensor will produce an output proportional to force within the specified performance limits.

**Table 3. Environmental Specifications**

Characteristic	Parameter
Humidity	0 %RH to 95 %RH, non-condensing
Vibration	15 g, 10 Hz to 2 kHz
Shock	100 g, 6 ms duration
Life <sup>1</sup>	1 million pressure cycles min.
Solder reflow	J-STD-020-D, MSL 1 (unlimited shelf life when stored at less than 30 °C and 85 %RH)

<sup>1</sup>Life may vary depending on specific application in which sensor is utilized.

## CAUTION

### PRODUCT SENSING SURFACE DAMAGE

- The sensing surface of the sensor is composed of a tough silicone gel. Ensure that the sensing surface is not used with media incompatible with silicones.
- Ensure that the sensing surface does not come into contact with sharp or hard objects.

**Failure to comply with these instructions may result in product damage.**

## NOTICE

In order for the TBF Series sensors to provide a linear and repeatable output, ensure the entire top surface of the gel is exposed to a uniform pressure. The silicone gel allows direct contact with many liquids or the gel may be protected with a thin, compliant membrane.

# Basic Force Sensors, TBF Series, Compensated/Unamplified

**Table 4. Sensor Pressure Type**

Pressure Type	Description
Gage	Output is proportional to the difference between applied pressure and atmospheric (ambient) pressure. Reference pressure is atmospheric pressure.

**Table 5. Material Composition**

Component	Description
Cover	high temperature polyamide
Substrate	not exposed - protected by silicone gel
Sensing surface	silicone gel

**Table 6. Pressure Range Specifications for 1 bar to 10 bar**

Pressure Range Order Code (see Figure 1)	Pressure Range		Unit	Overpressure	Pressure Accuracy <sup>1</sup> (%FSS)	Offset <sup>2</sup> (mV/V)	Full Scale Span <sup>3</sup> (mV/V)			Thermal Effect on Offset <sup>4</sup> (%FSS)	Thermal Effect on Span <sup>5</sup> (%FSS)
	Pmin.	Pmax.					Min.	Nom.	Max.		
Gage											
001BG	0	1	bar	4	±0.5	±0.3	4.90	5.10	5.30	±1.0	±1.0
1.6BG	0	1.6	bar	4	±0.5	±0.3	7.84	8.15	8.48	±1.0	±1.0
2.5BG	0	2.5	bar	8	±0.5	±0.15	6.10	6.35	6.59	±1.0	±0.75
004BG	0	4	bar	10	±0.5	±0.075	5.57	5.80	6.04	±1.0	±0.75
006BG	0	6	bar	17	±0.5	±0.075	5.08	5.30	5.54	±0.75	±0.75
010BG	0	10	bar	17	±0.5	±0.075	8.47	8.85	9.22	±0.50	±0.75

<sup>1</sup>Accuracy: The maximum deviation in output from a Best Fit Straight Line (BFSL) fitted to the output measured over the pressure range at 25 °C [77 °F]. Includes all errors due to pressure non-linearity, pressure hysteresis, and non-repeatability.

<sup>2</sup>Offset: The output signal obtained when the reference pressure is applied to all available pressure ports. Also known as “null” or “zero”.

<sup>3</sup>Full Scale Span: The algebraic difference between the output signal measured at the maximum and minimum limits of the pressure range (see Figure 1).

<sup>4</sup>Thermal effect on offset: The deviation in offset due to changes in temperature over the compensated temperature range, relative to offset measured at 25 °C.

<sup>5</sup>Thermal effect on span: The deviation in full scale span due to changes in temperature over the compensated temperature range, relative to full scale span measured at 25 °C.

# Basic Force Sensors, TBF Series, Compensated/Unamplified

Table 7. Pressure Range Specifications for 100 kPa to 1 MPa

Pressure Range Order Code (see Figure 1)	Pressure Range		Unit	Overpressure	Pressure Accuracy <sup>1</sup> (%FSS)	Offset <sup>2</sup> (mV/V)	Full Scale Span <sup>3</sup> (mV/V)			Thermal Effect on Offset <sup>4</sup> (%FSS) 0 °C to 50 °C	Thermal Effect on Span <sup>5</sup> (%FSS) 0 °C to 50 °C
	Pmin.	Pmax.					Min.	Nom.	Max.		
Gage											
100KG	0	100	kPa	400	±0.5	±0.3	4.90	5.10	5.30	±1.0	±1.0
160KG	0	160	kPa	400	±0.5	±0.3	7.84	8.15	8.48	±1.0	±1.0
250KG	0	250	kPa	800	±0.5	±0.15	6.10	6.35	6.59	±1.0	±0.75
400KG	0	400	kPa	1000	±0.5	±0.075	5.57	5.80	6.04	±1.0	±0.75
600KG	0	600	kPa	1700	±0.5	±0.075	5.08	5.30	5.54	±0.75	±0.75
001GG	0	1	MPa	1.70	±0.5	±0.075	8.47	8.85	9.22	±0.50	±0.75

<sup>1</sup>Accuracy: The maximum deviation in output from a Best Fit Straight Line (BFSL) fitted to the output measured over the pressure range at 25 °C [77 °F]. Includes all errors due to pressure non-linearity, pressure hysteresis, and non-repeatability.

<sup>2</sup>Offset: The output signal obtained when the reference pressure is applied to all available pressure ports. Also known as “null” or “zero”.

<sup>3</sup>Full Scale Span: The algebraic difference between the output signal measured at the maximum and minimum limits of the pressure range (see Figure 1).

<sup>4</sup>Thermal effect on offset: The deviation in offset due to changes in temperature over the compensated temperature range, relative to offset measured at 25 °C.

<sup>5</sup>Thermal effect on span: The deviation in full scale span due to changes in temperature over the compensated temperature range, relative to full scale span measured at 25 °C.

Table 8. Pressure Range Specifications for 15 psi to 150 psi

Pressure Range Order Code (see Figure 1)	Pressure Range		Unit	Overpressure	Pressure Accuracy <sup>1</sup> (%FSS)	Offset <sup>2</sup> (mV/V)	Full Scale Span <sup>3</sup> (mV/V)			Thermal Effect on Offset <sup>4</sup> (%FSS) 0 °C to 50 °C	Thermal Effect on Span <sup>5</sup> (%FSS) 0 °C to 50 °C
	Pmin.	Pmax.					Min.	Nom.	Max.		
Gage											
015PG	0	15	psi	60	±0.5	±0.3	5.06	5.25	5.49	±1.0	±1.0
030PG	0	30	psi	115	±0.5	±0.15	5.05	5.25	5.45	±1.0	±0.75
060PG	0	60	psi	145	±0.5	±0.075	5.76	6.00	6.24	±1.0	±0.75
100PG	0	100	psi	245	±0.5	±0.075	5.83	6.10	6.36	±0.75	±0.75
150PG	0	150	psi	245	±0.5	±0.075	8.65	9.15	9.55	±0.50	±0.75

<sup>1</sup>Accuracy: The maximum deviation in output from a Best Fit Straight Line (BFSL) fitted to the output measured over the pressure range at 25 °C [77 °F]. Includes all errors due to pressure non-linearity, pressure hysteresis, and non-repeatability.

<sup>2</sup>Offset: The output signal obtained when the reference pressure is applied to all available pressure ports. Also known as “null” or “zero”.

<sup>3</sup>Full Scale Span: The algebraic difference between the output signal measured at the maximum and minimum limits of the pressure range (see Figure 1).

<sup>4</sup>Thermal effect on offset: The deviation in offset due to changes in temperature over the compensated temperature range, relative to offset measured at 25 °C.

<sup>5</sup>Thermal effect on span: The deviation in full scale span due to changes in temperature over the compensated temperature range, relative to full scale span measured at 25 °C.

# Basic Force Sensors, TBF Series, Compensated/Unamplified

Figure 1. Nomenclature and Order Guide

For example, **TBFLPNS150PGUCV** defines a TBF Series Basic Force Sensor, Leadless SMT package, low-profile pressure port, silicone gel interface, 0 psi to 150 psi gage pressure range, unamplified output, compensated, constant supply voltage.

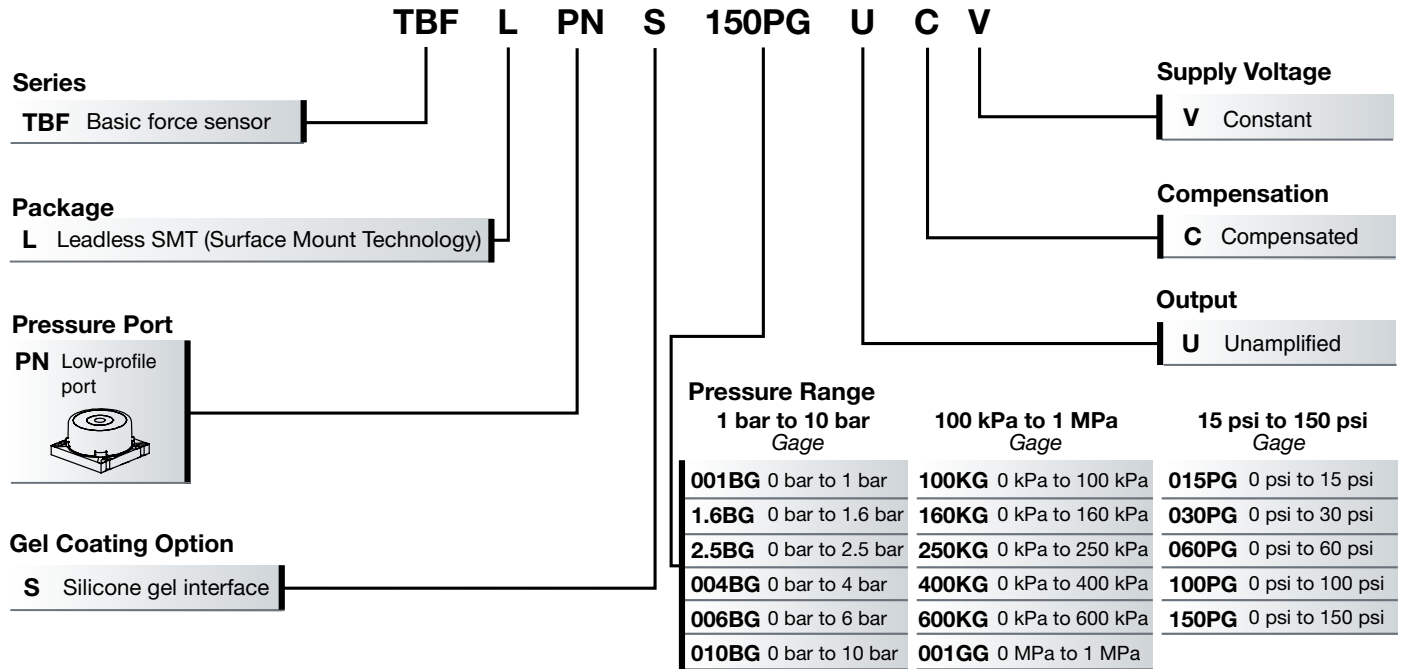
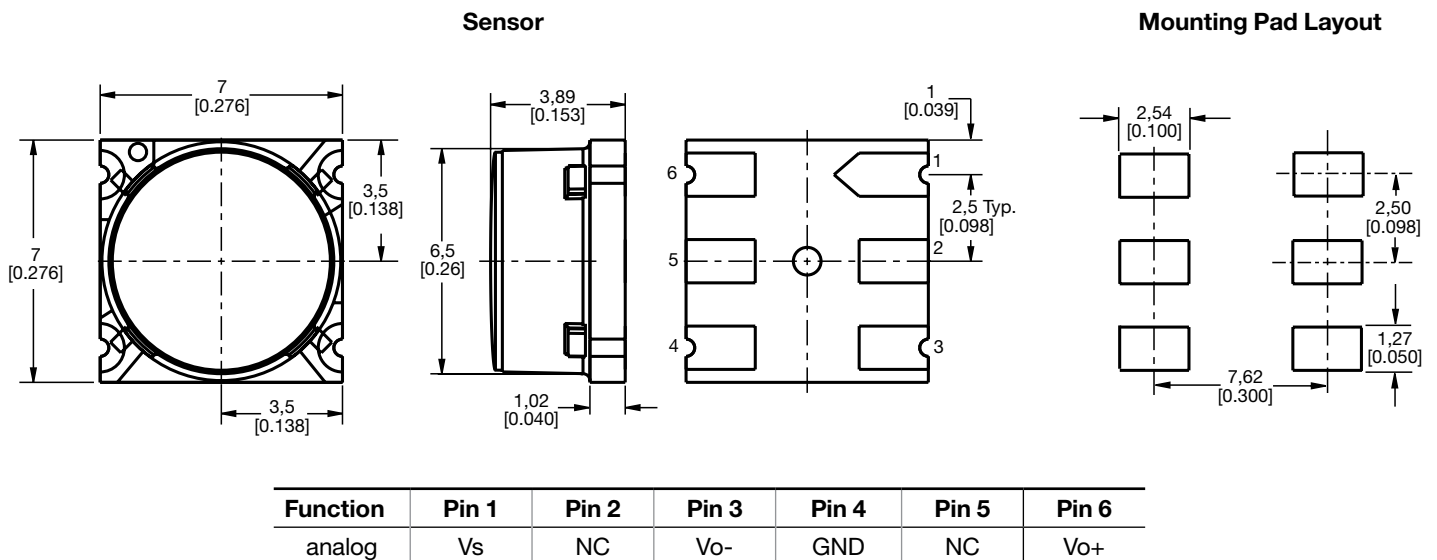

Figure 2. Leadless SMT Package Dimensional Drawings (For reference only: mm [in].)



## ADDITIONAL INFORMATION

The following associated literature is available at [sensing.honeywell.com](http://sensing.honeywell.com):

- Product Range Guide
- Product Line Guide
- Product Installation Instructions
- Technical Information:
  - Output Signal Adjustment and Temperature Compensation for Honeywell Basic Force Sensors, TBF Series, Compensated/Unamplified

### **⚠ WARNING** **PERSONAL INJURY**

DO NOT USE these products as safety or emergency stop devices or in any other application where failure of the product could result in personal injury.

**Failure to comply with these instructions could result in death or serious injury.**

### **⚠ WARNING** **MISUSE OF DOCUMENTATION**

- The information presented in this datasheet is for reference only. Do not use this document as a product installation guide.
- Complete installation, operation, and maintenance information is provided in the instructions supplied with each product.

**Failure to comply with these instructions could result in death or serious injury.**

## Find out more

Honeywell serves its customers through a worldwide network of sales offices, representatives and distributors.

For application assistance, current specifications, pricing or name of the nearest Authorized Distributor, contact your local sales office.

To learn more about Honeywell Sensing and Productivity Solutions' products, call **+1-815-235-6847** or **1-800-537-6945**, visit **[sensing.honeywell.com](http://sensing.honeywell.com)**, or e-mail inquiries to **[info.sc@honeywell.com](mailto:info.sc@honeywell.com)**

Sensing and Productivity Solutions  
Honeywell  
1985 Douglas Drive North  
Golden Valley, MN 55422  
**[honeywell.com](http://honeywell.com)**

## Warranty/Remedy

Honeywell warrants goods of its manufacture as being free of defective materials and faulty workmanship. Honeywell's standard product warranty applies unless agreed to otherwise by Honeywell in writing; please refer to your order acknowledgement or consult your local sales office for specific warranty details. If warranted goods are returned to Honeywell during the period of coverage, Honeywell will repair or replace, at its option, without charge those items it finds defective.

**The foregoing is buyer's sole remedy and is in lieu of all other warranties, expressed or implied, including those of merchantability and fitness for a particular purpose. In no event shall Honeywell be liable for consequential, special, or indirect damages.**

While we provide application assistance personally, through our literature and the Honeywell web site, it is up to the customer to determine the suitability of the product in the application.

Specifications may change without notice. The information we supply is believed to be accurate and reliable as of this printing. However, we assume no responsibility for its use.

# Honeywell