



Chipsmall Limited consists of a professional team with an average of over 10 year of expertise in the distribution of electronic components. Based in Hongkong, we have already established firm and mutual-benefit business relationships with customers from,Europe,America and south Asia,supplying obsolete and hard-to-find components to meet their specific needs.

With the principle of “Quality Parts,Customers Priority,Honest Operation,and Considerate Service”,our business mainly focus on the distribution of electronic components. Line cards we deal with include Microchip,ALPS,ROHM,Xilinx,Pulse,ON,Everlight and Freescale. Main products comprise IC,Modules,Potentiometer,IC Socket,Relay,Connector.Our parts cover such applications as commercial,industrial, and automotives areas.

We are looking forward to setting up business relationship with you and hope to provide you with the best service and solution. Let us make a better world for our industry!



## Contact us

Tel: +86-755-8981 8866 Fax: +86-755-8427 6832

Email & Skype: info@chipsmall.com Web: www.chipsmall.com

Address: A1208, Overseas Decoration Building, #122 Zhenhua RD., Futian, Shenzhen, China



## PFM/PWM Step-Down DC/DC Controller

### Features

- 57 $\mu$ A (Typ) Supply Current
- 1A Output Current
- 0.5 $\mu$ A Shutdown Mode
- 300kHz Switching Frequency for Small Inductor Size
- Programmable Soft-Start
- 92% Typical Efficiency
- Small Package: 5-Pin SOT-23A

### Applications

- Palmtops
- Battery-Operated Systems
- Portable Instruments
- Positive LCD Bias Generators
- Portable Communicators
- Hand-Held Scanners
- 5V to 3V Down Converters

### Device Selection Table

Part Number	Output Voltage (V)*	Package	Osc. Freq. (kHz)	Operating Temp. Range
TC105503ECT	5.0	5-Pin SOT-23A	300	-40°C to +85°C
TC105333ECT	3.3	5-Pin SOT-23A	300	-40°C to +85°C
TC105303ECT	3.0	5-Pin SOT-23A	300	-40°C to +85°C

\*Other output voltages are available. Please contact Microchip Technology Inc. for details.

### Functional Block Diagram

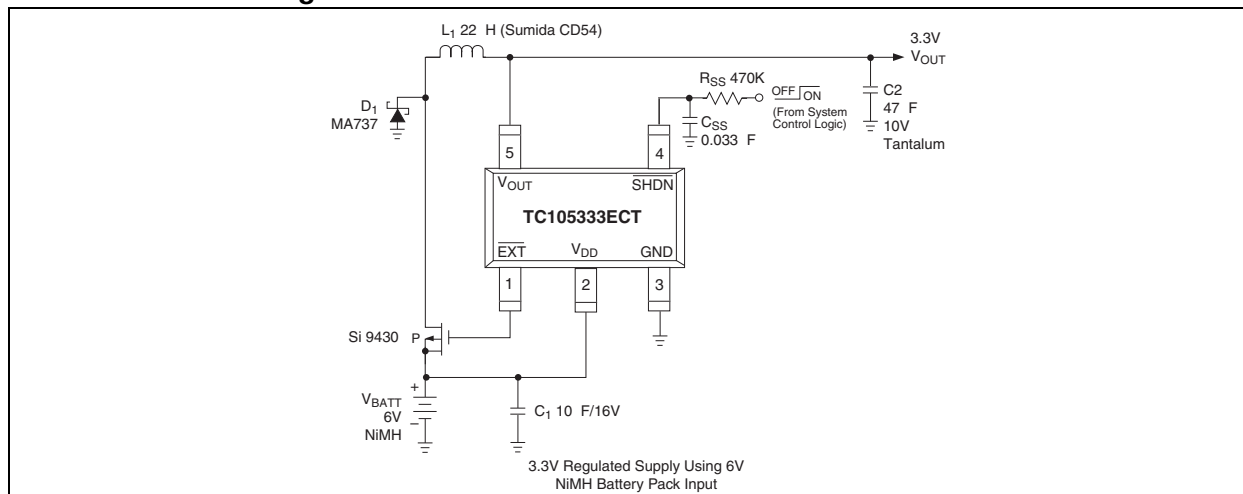

### Package Type

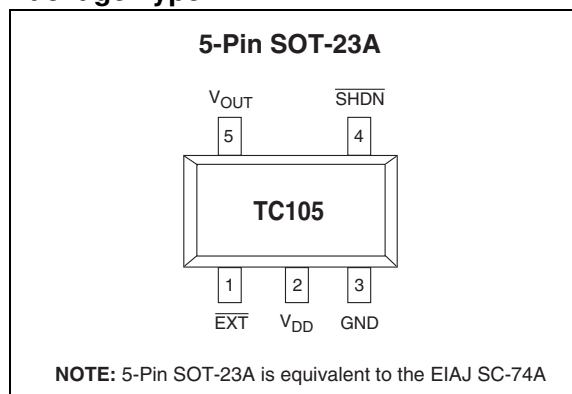

### General Description

The TC105 is a step-down (Buck) switching controller that furnishes output currents of up to 1A (max) while delivering a typical efficiency of 92%. The TC105 normally operates in pulse width modulation mode (PWM), but automatically switches to pulse frequency modulation (PFM) at low output loads for greater efficiency. Oscillator frequency is 300kHz, allowing use of small (22 $\mu$ H) inductors. Supply current draw is only 102 $\mu$ A (max), and is reduced to less than 0.5 $\mu$ A when the SHDN input is brought low. Regulator operation is suspended during shutdown. The TC105 accepts a maximum input voltage of 10V.

The TC105 is available in a small 5-Pin SOT-23A package, occupies minimum board space and is ideal for a wide range of applications.

# TC105

## 1.0 ELECTRICAL CHARACTERISTICS

### Absolute Maximum Ratings\*

Voltage on $V_{DD}$ .....	-0.3V to +12V
$\overline{EXT}$ Output Current .....	$\pm 100$ mA
Voltage on $V_{OUT}$ , $\overline{EXT}$ , $\overline{SHDN}$ Pins .....	-0.3V to $V_{DD} + 0.3$ V
Power Dissipation.....	150mW
Operating Temperature Range.....	-40°C to +85°C
Storage Temperature Range .....	-40°C to +125°C

\*Stresses above those listed under "Absolute Maximum Ratings" may cause permanent damage to the device. These are stress ratings only and functional operation of the device at these or any other conditions above those indicated in the operation sections of the specifications is not implied. Exposure to Absolute Maximum Rating conditions for extended periods may affect device reliability.

### TC105 ELECTRICAL SPECIFICATIONS

Electrical Characteristics: Note 1, $f_{OSC} = 300$ kHz; $T_A = 25^\circ\text{C}$ , unless otherwise noted.						
Symbol	Parameter	Min	Typ	Max	Units	Test Conditions
$V_{DD}$	Operating Supply Voltage	2.2	—	10.0	V	
$V_{DDMIN}$	Minimum Input Voltage	0.9	—	2.2	V	$\overline{EXT} = \text{High}$ ; No external components; $V_{OUT} = 0\text{V}$ , $\overline{SHDN} = V_{IN}$
$I_{DD}$	Operating Supply Current	—	57 67	102 122	$\mu\text{A}$	No external components; $V_R = 3.0\text{V}$ , 3.3V $V_{OUT} = 0\text{V}$ , $\overline{SHDN} = V_{IN}$ $V_R = 5.0\text{V}$
$I_{STBY}$	Standby Supply Current	—	15 16	27 29	$\mu\text{A}$	No external components; $V_R = 3.0\text{V}$ , 3.3V $V_{OUT} = \overline{SHDN} = V_{IN}$ $V_R = 5.0\text{V}$
$I_{SHDN}$	Shutdown Supply Current	—	—	0.5	$\mu\text{A}$	$\overline{SHDN} = \text{GND}$
$f_{OSC}$	Oscillator Frequency	255	300	345	kHz	$V_{IN} = V_{OUT} + 0.3\text{V}$
$V_{OUT}$	Output Voltage	$V_R \times 0.975$	$V_R$	$V_R \times 1.025$		Note 2
DTYMAX	Maximum Duty Cycle (PWM Mode)	100	—	—	%	
DTYPFM	Duty Cycle (PFM Mode)	15	25	35	%	$I_{OUT} = 0\text{mA}$
$V_{IH}$	$\overline{SHDN}$ Input Logic High	0.65	—	—	V	$V_{OUT} = 0\text{V}$ , No external components
$V_{IL}$	$\overline{SHDN}$ Input Logic Low	—	—	0.20	V	$V_{OUT} = 0\text{V}$ , No external components
REXTH	$\overline{EXT}$ ON Resistance to $V_{DD}$	—	17 16 12	24 22 17	$\Omega$	No external components; $V_R = 3.0\text{V}$ $V_R = 3.3\text{V}$ $V_R = 5.0\text{V}$ $V_{OUT} = \overline{SHDN} = V_{IN}$ , $V_{EXT} = (V_{IN} - 0.4\text{V})$
REXTL	$\overline{EXT}$ ON Resistance to GND	—	15 14 10	20 19 14	$\Omega$	No external components; $V_R = 3.0\text{V}$ $V_R = 3.3\text{V}$ $V_R = 5.0\text{V}$ $V_{OUT} = 0\text{V}$ , $\overline{SHDN} = V_{IN}$ , $V_{EXT} = 0.4\text{V}$
$\eta$	Efficiency	—	92	—	%	

- Note 1:**  $V_R = 3.0\text{V}$ ,  $V_{IN} = 4.5\text{V}$ ,  $I_{OUT} = 200\text{mA}$   
 $V_R = 3.3\text{V}$ ,  $V_{IN} = 5.0\text{V}$ ,  $I_{OUT} = 220\text{mA}$   
 $V_R = 5.0\text{V}$ ,  $V_{IN} = 7.5\text{V}$ ,  $I_{OUT} = 320\text{mA}$   
**Note 2:**  $V_R$  is the factory output voltage setting.

## 2.0 PIN DESCRIPTIONS

The descriptions of the pins are listed in Table 2-1.

**TABLE 2-1: PIN FUNCTION TABLE**

Pin No. (5-Pin SOT-23A)	Symbol	Description
1	$\overline{\text{EXT}}$	Switch transistor control output. This terminal connects to the gate of an external P-channel MOSFET (or to the base of an external PNP transistor through a current limiting resistor).
2	$V_{DD}$	Power supply voltage input.
3	GND	Ground terminal.
4	$\overline{\text{SHDN}}$	Shutdown input (active low). The device enters a low power shutdown state when this input is brought low. During shutdown, regulator action is suspended, and supply current is reduced to less than 0.5 $\mu$ A. The device resumes normal operation when $\overline{\text{SHDN}}$ is again brought high.
5	$V_{OUT}$	Voltage sense input. This input senses output voltage for regulation and must be connected to the output voltage node as shown in the application schematic in this data sheet.

## 3.0 DETAILED DESCRIPTION

The TC105 is a PFM/PWM step-down DC/DC controller for use in systems operating from two or more cells, or in line-powered applications. It uses PWM as the primary modulation scheme, but automatically converts to PFM at output duty cycles less than approximately 10%. The conversion to PFM provides reduced supply current, and therefore higher operating efficiency at low loads. The TC105 uses an external switching transistor, allowing construction of switching regulators with output currents of up to 1A.

The TC105 consumes only 102 $\mu$ A, max, of supply current when  $V_{IN} = 5V$  and  $V_{OUT} = 3.3V$ , and can be placed in a 0.5 $\mu$ A shutdown mode by bringing the shutdown input ( $\overline{SHDN}$ ) low. The regulator remains disabled while in shutdown mode, and output voltage discharges to zero through the load. Normal operation resumes when  $\overline{SHDN}$  is brought high. Other features include a built-in undervoltage lockout (UVLO) and externally programmable soft start time.

### 3.1 Low Power Shutdown Mode

The TC105 enters a low power shutdown mode when  $\overline{SHDN}$  is brought low. While in shutdown, the oscillator is disabled and the output switch is shut off. Normal regulator operation resumes when  $\overline{SHDN}$  is again brought high.  $\overline{SHDN}$  may be tied to the input supply if not used.

### 3.2 Soft Start

Soft start allows the output voltage to gradually ramp from 0 to rated output value during start-up. This action minimizes (or eliminates) overshoot, and in general, reduces stress on circuit components. Figure 4-1 shows the circuit required to implement soft start (values of 470K and 0.033 $\mu$ F for  $R_{SS}$  and  $C_{SS}$  respectively, are adequate for most applications).

### 3.3 Undervoltage Lockout (UVLO)

The TC105 is disabled when  $V_{IN}$  is below the undervoltage lockout threshold. This threshold is equal to the guaranteed minimum operating voltage for the TC105 (i.e., 2.2V). When UVLO is active, the TC105 is completely disabled.

### 3.4 Input Bypass Capacitors

Using an input bypass capacitor reduces peak current transients drawn from the input supply and reduces the switching noise generated by the regulator. The source impedance of the input supply determines the size of the capacitor that should be used.

### 3.5 Output Capacitor

The effective series resistance of the output capacitor directly affects the amplitude of the output voltage ripple. (The product of the peak inductor current and the ESR determines output ripple amplitude.) Therefore, a capacitor with the lowest possible ESR should be selected. Smaller capacitors are acceptable for light loads or in applications where ripple is not a concern. The Sprague 595D series of tantalum capacitors are among the smallest of all low ESR surface mount capacitors available. Table 4-1 lists suggested components and suppliers.

### 3.6 Inductor Selection

Selecting the proper inductor value is a trade-off between physical size and power conversion requirements. Lower value inductors cost less, but result in higher ripple current and core losses. They are also more prone to saturate since the coil current ramps faster and could overshoot the desired peak value. This not only reduces efficiency, but could also cause the current rating of the external components to be exceeded. Larger inductor values reduce both ripple current and core losses, but are larger in physical size and tend to increase the start-up time slightly.

A 22 $\mu$ H inductor is recommended as the best overall compromise. For highest efficiency, use inductors with a low DC resistance (less than 20 m $\Omega$ ). To minimize radiated noise, consider using a toroid, pot core or shielded-bobbin inductor.

### 3.7 Output Diode

The high operating frequency of the TC105 requires a high-speed diode. Schottky diodes such as the MA737 or 1N5817 through 1N5823 (and the equivalent surface mount versions) are recommended. Select a diode whose average current rating is greater than the peak inductor current and whose voltage rating is higher than  $V_{DDMAX}$ .

### 3.8 External Switching Transistor Selection

$\overline{\text{EXT}}$  is a complementary output with a maximum ON resistance of  $22\Omega$  to  $V_{\text{DD}}$  when high and  $19\Omega$  to ground when low. It is designed to directly drive a P-channel MOSFET or a PNP bipolar transistor through a base current limiting resistor (Figure 4-2). A PNP transistor is recommended in applications where  $V_{\text{IN}}$  is less than 2.5V. Otherwise, a P-channel MOSFET is preferred as it affords the highest efficiency because it does not draw any gate drive current. However, P-channel MOSFETs are typically more expensive than bipolar transistors.

P-channel MOSFET selection is determined mainly by the on-resistance, gate-source threshold, and gate charge requirements. Also, the drain-to-source and gate-to-source breakdown voltage ratings must be greater than  $V_{\text{DDMAX}}$ . The total gate charge specification should be less than 100nC for best efficiency. The MOSFET must be capable of handling the required peak inductor current, and should have a very low on-resistance at that current. For example, an Si9430 MOSFET has a drain-to-source rating of -20V, and a typical on-resistance  $r_{\text{DS(on)}}$  of  $0.07\Omega$  at 2A, with  $V_{\text{GS}} = -4.5\text{V}$ . Table 4-1 lists suppliers of external components recommended for use with the TC105.

#### 3.8.1 BOARD LAYOUT GUIDELINES

As with all inductive switching regulators, the TC105 generates fast switching waveforms, which radiate noise. Interconnecting lead lengths should be minimized to keep stray capacitance, trace resistance and radiated noise as low as possible. In addition, the GND pin, input bypass capacitor and output filter capacitor ground leads should be connected to a single point. The input capacitor should be placed as close to power and ground pins of the TC105 as possible. The length of the  $\overline{\text{EXT}}$  trace must also be kept as short as possible.

# TC105

## 4.0 APPLICATIONS

### 4.1 Circuit Examples

Figure 4-3 shows a TC105 using a PNP switching transistor (Zetex FZT749) that has an  $h_{FE}$  of 180 and  $V_{CESAT}$  of 100 mV at  $I_C = 1A$ . Other high beta transistors can be used, but the values of  $R_B$  and  $C_B$  may need adjustment if  $h_{FE}$  is significantly different from that of the FZT749.

The circuit of Figure 4-4 utilizes a P-channel MOSFET switching transistor (Silconix Si9430). This transistor is a member of the Littlefoot™ family of small outline MOSFETs.

FIGURE 4-1: SOFT START CIRCUIT

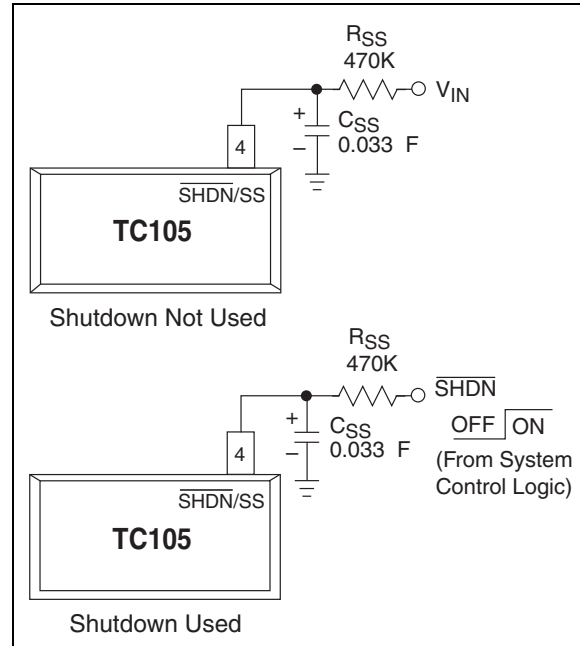
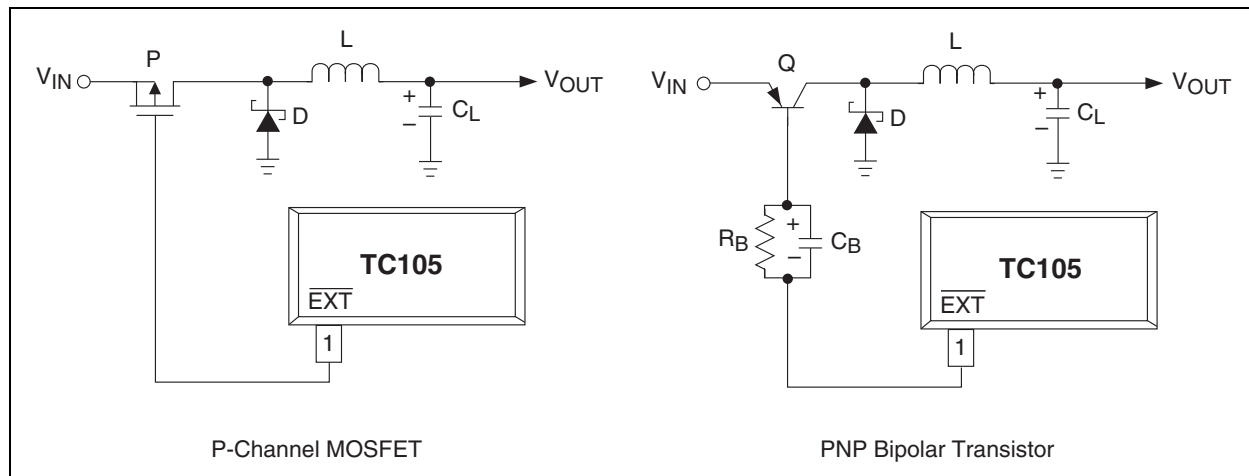
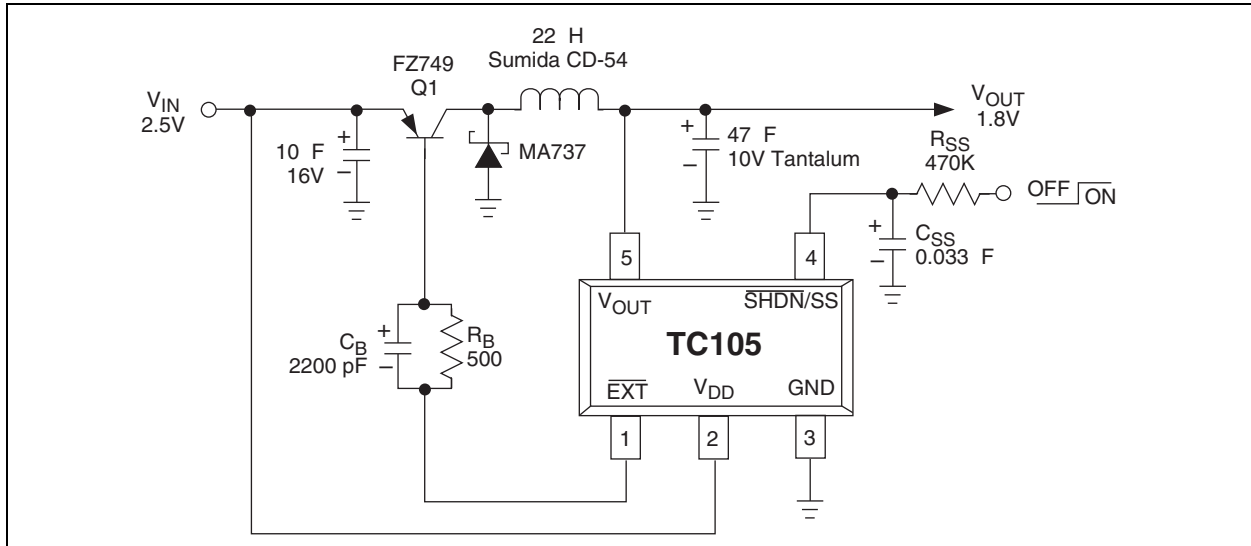

FIGURE 4-2: EXTERNAL TRANSISTOR CONNECTION



**FIGURE 4-3: REGULATOR USING PNP TRANSISTOR**



**FIGURE 4-4: REGULATOR USING P-CHANNEL MOSFET**

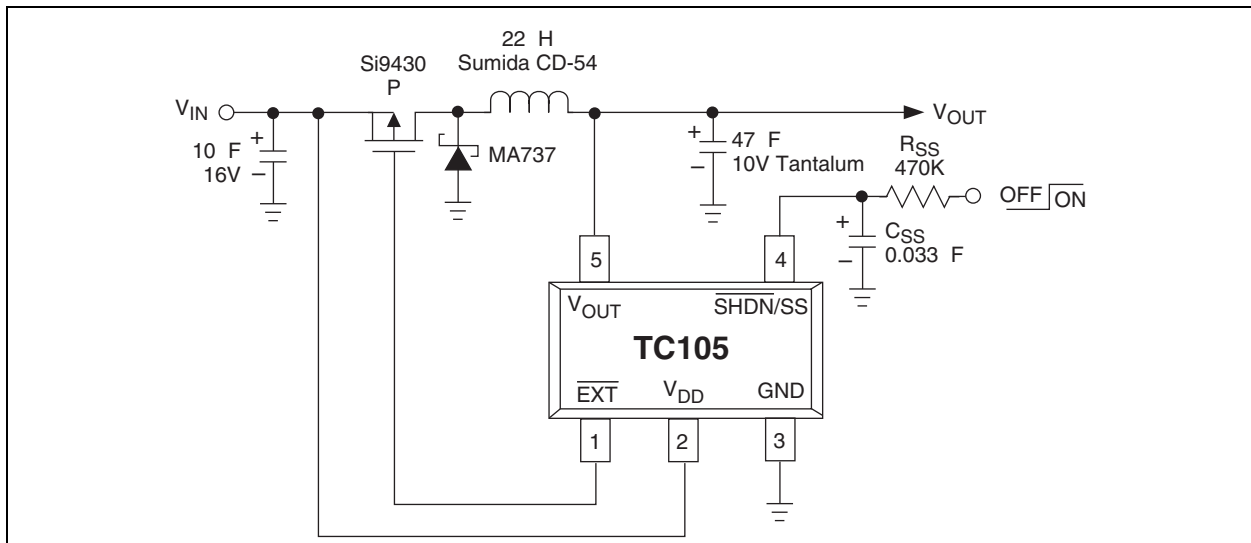

**TABLE 4-1: SUGGESTED COMPONENTS AND SUPPLIERS**

Type	Inductors	Capacitors	Diodes	Transistors
<b>Surface Mount</b>	Sumida CD54 Series CDRH Series  Coilcraft DO Series	AVX TPS Series  Sprague 595D Series	ON Semiconductor MBRS340T3  Nihon NSQ Series  Matsushita MA737	Silconix Little Foot MOSFET Series  Zetex FZT749 PNP Bipolar Transistor  Toshiba 2SA1213 PNP Transistor
<b>Miniature Through-Hole</b>	Sumida RCH Series	Sanyo OS-CON Series	IRC OAR Series	
<b>Standard Through-Hole</b>	Coilcraft PCH Series  Coiltronics CTX Series	Nichicon PL Series  United Chemi-Con LXF Series		ON Semiconductor TMOS Power MOSFETs (i.e., MTP30P06V)



# TC105

## 5.0 PACKAGING INFORMATION

### 5.1 Package Marking Information

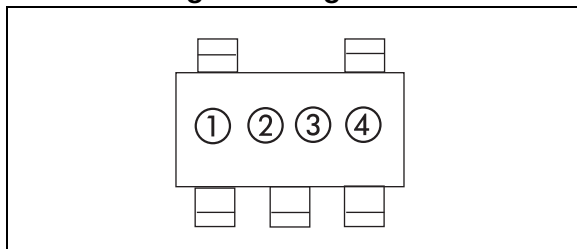

① represents product classification; TC105 = M

② represents first integer of voltage

Symbol (300kHz)	Voltage
<u>1</u>	1.
<u>2</u>	2.
<u>3</u>	3.
<u>4</u>	4.
<u>5</u>	5.
<u>6</u>	6.

③ represents first decimal of voltage

Symbol (300kHz)	Voltage
A	.0
B	.1
C	.2
D	.3
E	.4
F	.5
H	.6
K	.7
L	.8
M	.9

④ represents production lot ID code

## 5.2 Taping Form

### Component Taping Orientation for 5-Pin SOT-23A (EIAJ SC-74A) Devices

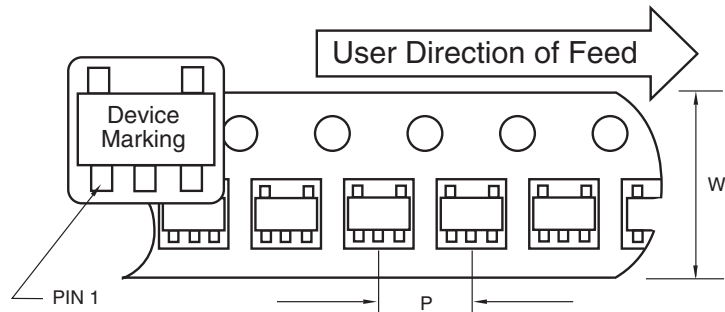

Standard Reel Component Orientation  
TR Suffix Device  
(Mark Right Side Up)

Carrier Tape, Number of Components Per Reel and Reel Size

Package	Carrier Width (W)	Pitch (P)	Part Per Full Reel	Reel Size
5-Pin SOT-23A	8 mm	4 mm	3000	7 in

## 5.3 Package Dimensions

**Note:** For the most current package drawings, please see the Microchip Packaging Specification located at <http://www.microchip.com/packaging>

### SOT-23A-5

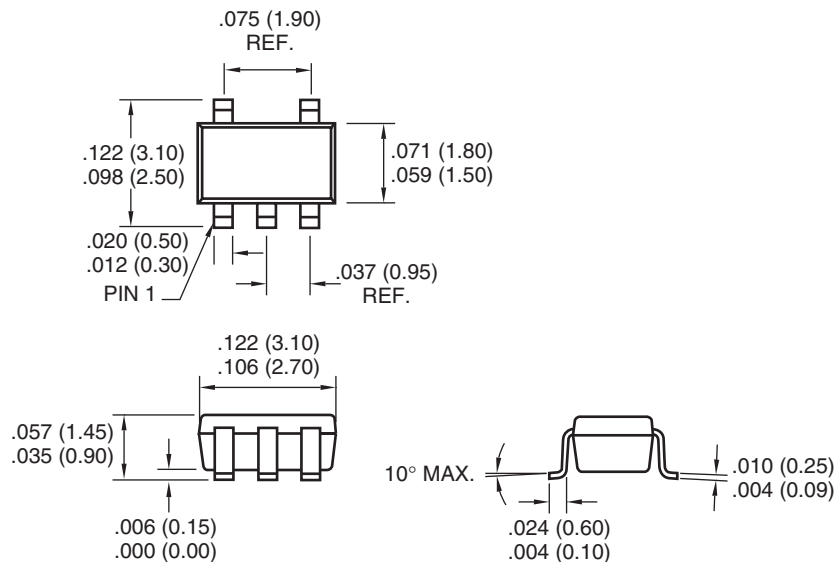

Dimensions: inches (mm)

# TC105

---

## REVISION HISTORY

### Revision C (November 2012)

Added a note to the package outline drawing.

## **Sales and Support**

### **Data Sheets**

Products supported by a preliminary Data Sheet may have an errata sheet describing minor operational differences and recommended workarounds. To determine if an errata sheet exists for a particular device, please contact one of the following:

1. Your local Microchip sales office
2. The Microchip Worldwide Site ([www.microchip.com](http://www.microchip.com))

Please specify which device, revision of silicon and Data Sheet (include Literature #) you are using.

### **New Customer Notification System**

Register on our web site ([www.microchip.com/cn](http://www.microchip.com/cn)) to receive the most current information on our products.

# TC105

---

---

NOTES:

---

---

**Note the following details of the code protection feature on Microchip devices:**

- Microchip products meet the specification contained in their particular Microchip Data Sheet.
- Microchip believes that its family of products is one of the most secure families of its kind on the market today, when used in the intended manner and under normal conditions.
- There are dishonest and possibly illegal methods used to breach the code protection feature. All of these methods, to our knowledge, require using the Microchip products in a manner outside the operating specifications contained in Microchip's Data Sheets. Most likely, the person doing so is engaged in theft of intellectual property.
- Microchip is willing to work with the customer who is concerned about the integrity of their code.
- Neither Microchip nor any other semiconductor manufacturer can guarantee the security of their code. Code protection does not mean that we are guaranteeing the product as “unbreakable.”

Code protection is constantly evolving. We at Microchip are committed to continuously improving the code protection features of our products. Attempts to break Microchip's code protection feature may be a violation of the Digital Millennium Copyright Act. If such acts allow unauthorized access to your software or other copyrighted work, you may have a right to sue for relief under that Act.

---

Information contained in this publication regarding device applications and the like is provided only for your convenience and may be superseded by updates. It is your responsibility to ensure that your application meets with your specifications. MICROCHIP MAKES NO REPRESENTATIONS OR WARRANTIES OF ANY KIND WHETHER EXPRESS OR IMPLIED, WRITTEN OR ORAL, STATUTORY OR OTHERWISE, RELATED TO THE INFORMATION, INCLUDING BUT NOT LIMITED TO ITS CONDITION, QUALITY, PERFORMANCE, MERCHANTABILITY OR FITNESS FOR PURPOSE. Microchip disclaims all liability arising from this information and its use. Use of Microchip devices in life support and/or safety applications is entirely at the buyer's risk, and the buyer agrees to defend, indemnify and hold harmless Microchip from any and all damages, claims, suits, or expenses resulting from such use. No licenses are conveyed, implicitly or otherwise, under any Microchip intellectual property rights.

#### **Trademarks**

The Microchip name and logo, the Microchip logo, dsPIC, FlashFlex, KEELOQ, KEELOQ logo, MPLAB, PIC, PICmicro, PICSTART, PIC<sup>32</sup> logo, rPIC, SST, SST Logo, SuperFlash and UNI/O are registered trademarks of Microchip Technology Incorporated in the U.S.A. and other countries.

FilterLab, Hampshire, HI-TECH C, Linear Active Thermistor, MTP, SEEVAL and The Embedded Control Solutions Company are registered trademarks of Microchip Technology Incorporated in the U.S.A.

Silicon Storage Technology is a registered trademark of Microchip Technology Inc. in other countries.

Analog-for-the-Digital Age, Application Maestro, BodyCom, chipKIT, chipKIT logo, CodeGuard, dsPICDEM, dsPICDEM.net, dsPICworks, dsSPEAK, ECAN, ECONOMONITOR, FanSense, HI-TIDE, In-Circuit Serial Programming, ICSP, Mindi, MiWi, MPASM, MPF, MPLAB Certified logo, MPLIB, MPLINK, mTouch, Omniclient Code Generation, PICC, PICC-18, PICDEM, PICDEM.net, PICkit, PICtail, REAL ICE, rLAB, Select Mode, SQI, Serial Quad I/O, Total Endurance, TSHARC, UniWinDriver, WiperLock, ZENA and Z-Scale are trademarks of Microchip Technology Incorporated in the U.S.A. and other countries.

SQTP is a service mark of Microchip Technology Incorporated in the U.S.A.

GestIC and ULPP are registered trademarks of Microchip Technology Germany II GmbH & Co. & KG, a subsidiary of Microchip Technology Inc., in other countries.

All other trademarks mentioned herein are property of their respective companies.

© 2001-2012, Microchip Technology Incorporated, Printed in the U.S.A., All Rights Reserved.

 Printed on recycled paper.

ISBN: 9781620767481

**QUALITY MANAGEMENT SYSTEM**  
**CERTIFIED BY DNV**  
**== ISO/TS 16949 ==**

*Microchip received ISO/TS-16949:2009 certification for its worldwide headquarters, design and wafer fabrication facilities in Chandler and Tempe, Arizona; Gresham, Oregon and design centers in California and India. The Company's quality system processes and procedures are for its PIC<sup>®</sup> MCUs and dsPIC<sup>®</sup> DSCs, KEELOQ<sup>®</sup> code hopping devices, Serial EEPROMs, microperipherals, nonvolatile memory and analog products. In addition, Microchip's quality system for the design and manufacture of development systems is ISO 9001:2000 certified.*



# MICROCHIP

## Worldwide Sales and Service

### AMERICAS

**Corporate Office**  
2355 West Chandler Blvd.  
Chandler, AZ 85224-6199  
Tel: 480-792-7200  
Fax: 480-792-7277  
Technical Support:  
<http://www.microchip.com/support>  
Web Address:  
[www.microchip.com](http://www.microchip.com)

**Atlanta**  
Duluth, GA  
Tel: 678-957-9614  
Fax: 678-957-1455

**Boston**  
Westborough, MA  
Tel: 774-760-0087  
Fax: 774-760-0088

**Chicago**  
Itasca, IL  
Tel: 630-285-0071  
Fax: 630-285-0075

**Cleveland**  
Independence, OH  
Tel: 216-447-0464  
Fax: 216-447-0643

**Dallas**  
Addison, TX  
Tel: 972-818-7423  
Fax: 972-818-2924

**Detroit**  
Farmington Hills, MI  
Tel: 248-538-2250  
Fax: 248-538-2260

**Indianapolis**  
Noblesville, IN  
Tel: 317-773-8323  
Fax: 317-773-5453

**Los Angeles**  
Mission Viejo, CA  
Tel: 949-462-9523  
Fax: 949-462-9608

**Santa Clara**  
Santa Clara, CA  
Tel: 408-961-6444  
Fax: 408-961-6445

**Toronto**  
Mississauga, Ontario,  
Canada  
Tel: 905-673-0699  
Fax: 905-673-6509

### ASIA/PACIFIC

**Asia Pacific Office**  
Suites 3707-14, 37th Floor  
Tower 6, The Gateway  
Harbour City, Kowloon  
Hong Kong  
Tel: 852-2401-1200  
Fax: 852-2401-3431

**Australia - Sydney**  
Tel: 61-2-9868-6733  
Fax: 61-2-9868-6755

**China - Beijing**  
Tel: 86-10-8569-7000  
Fax: 86-10-8528-2104

**China - Chengdu**  
Tel: 86-28-8665-5511  
Fax: 86-28-8665-7889

**China - Chongqing**  
Tel: 86-23-8980-9588  
Fax: 86-23-8980-9500

**China - Hangzhou**  
Tel: 86-571-2819-3187  
Fax: 86-571-2819-3189

**China - Hong Kong SAR**  
Tel: 852-2401-1200  
Fax: 852-2401-3431

**China - Nanjing**  
Tel: 86-25-8473-2460  
Fax: 86-25-8473-2470

**China - Qingdao**  
Tel: 86-532-8502-7355  
Fax: 86-532-8502-7205

**China - Shanghai**  
Tel: 86-21-5407-5533  
Fax: 86-21-5407-5066

**China - Shenyang**  
Tel: 86-24-2334-2829  
Fax: 86-24-2334-2393

**China - Shenzhen**  
Tel: 86-755-8203-2660  
Fax: 86-755-8203-1760

**China - Wuhan**  
Tel: 86-27-5980-5300  
Fax: 86-27-5980-5118

**China - Xian**  
Tel: 86-29-8833-7252  
Fax: 86-29-8833-7256

**China - Xiamen**  
Tel: 86-592-2388138  
Fax: 86-592-2388130

**China - Zhuhai**  
Tel: 86-756-3210040  
Fax: 86-756-3210049

### ASIA/PACIFIC

**India - Bangalore**  
Tel: 91-80-3090-4444  
Fax: 91-80-3090-4123

**India - New Delhi**  
Tel: 91-11-4160-8631  
Fax: 91-11-4160-8632

**India - Pune**  
Tel: 91-20-2566-1512  
Fax: 91-20-2566-1513

**Japan - Osaka**  
Tel: 81-66-152-7160  
Fax: 81-66-152-9310

**Japan - Yokohama**  
Tel: 81-45-471-6166  
Fax: 81-45-471-6122

**Korea - Daegu**  
Tel: 82-53-744-4301  
Fax: 82-53-744-4302

**Korea - Seoul**  
Tel: 82-2-554-7200  
Fax: 82-2-558-5932 or  
82-2-558-5934

**Malaysia - Kuala Lumpur**  
Tel: 60-3-6201-9857  
Fax: 60-3-6201-9859

**Malaysia - Penang**  
Tel: 60-4-227-8870  
Fax: 60-4-227-4068

**Philippines - Manila**  
Tel: 63-2-634-9065  
Fax: 63-2-634-9069

**Singapore**  
Tel: 65-6334-8870  
Fax: 65-6334-8850

**Taiwan - Hsin Chu**  
Tel: 886-3-5778-366  
Fax: 886-3-5770-955

**Taiwan - Kaohsiung**  
Tel: 886-7-213-7828  
Fax: 886-7-330-9305

**Taiwan - Taipei**  
Tel: 886-2-2508-8600  
Fax: 886-2-2508-0102

**Thailand - Bangkok**  
Tel: 66-2-694-1351  
Fax: 66-2-694-1350

### EUROPE

**Austria - Wels**  
Tel: 43-7242-2244-39  
Fax: 43-7242-2244-393

**Denmark - Copenhagen**  
Tel: 45-4450-2828  
Fax: 45-4485-2829

**France - Paris**  
Tel: 33-1-69-53-63-20  
Fax: 33-1-69-30-90-79

**Germany - Munich**  
Tel: 49-89-627-144-0  
Fax: 49-89-627-144-44

**Italy - Milan**  
Tel: 39-0331-742611  
Fax: 39-0331-466781

**Netherlands - Drunen**  
Tel: 31-416-690399  
Fax: 31-416-690340

**Spain - Madrid**  
Tel: 34-91-708-08-90  
Fax: 34-91-708-08-91

**UK - Wokingham**  
Tel: 44-118-921-5869  
Fax: 44-118-921-5820

10/26/12